



US00D474510S

(12) **United States Design Patent** (10) **Patent No.:** **US D474,510 S**
Fayram et al. (45) **Date of Patent:** **** May 13, 2003**

(54) **PORTABLE ELECTRONIC GAMING DEVICE**

(75) Inventors: **Richard Fayram**, Palo Alto, CA (US);
Charles Dewey, Fremont, CA (US);
Christian Wright, San Jose, CA (US)

(73) Assignee: **LIF Capital Group, LLC**, Woodland Hills, CA (US)

(**) Term: **14 Years**

(21) Appl. No.: **29/150,890**

(22) Filed: **Nov. 28, 2001**

(51) **LOC (7) Cl.** **21-01**

(52) **U.S. Cl.** **D21/330**

(58) **Field of Search** D21/324, 329,
D21/330; D14/496, 125; 463/1, 2, 29-35,
46, 47; 273/148 B

(56) **References Cited**

U.S. PATENT DOCUMENTS

D275,971 S	*	10/1984	Yokoi	D21/330
4,855,725 A	*	8/1989	Fernandez	345/173
4,937,564 A	*	6/1990	Oberg	345/168
5,181,009 A	*	1/1993	Perona	463/47
D333,493 S	*	2/1993	Sato	D21/330
5,265,009 A	*	11/1993	Colavita	463/1
D346,408 S	*	4/1994	Lee	D21/330
D415,212 S	*	10/1999	Hornsby et al.	D21/330
D421,001 S	*	2/2000	Miyashita	D21/330

* cited by examiner

Primary Examiner—Prabhakar Deshmukh
(74) *Attorney, Agent, or Firm*—Stattler Johansen & Adeli, LLP

(57) **CLAIM**

The ornamental design for a portable electronic gaming device, as shown and described.

DESCRIPTION

FIG. 1 illustrates a front and top perspective view of a portable electronic gaming device shown in an open position;

FIG. 2 illustrates a front and top perspective view of a portable electronic gaming device shown in an alternate position;

FIG. 3 illustrates a front and top perspective view of a portable electronic gaming device shown in a closed position;

FIG. 4 illustrates a rear and top perspective view of a portable electronic gaming device shown in an open position;

FIG. 5 illustrates a rear and top perspective view of a portable electronic gaming device shown in a closed position;

FIG. 6 illustrates a rear and bottom perspective view of a portable electronic gaming device shown in an open position; and,

FIG. 7 illustrates a rear and bottom perspective view of a portable electronic gaming device shown in a closed position.

The drawings FIGS. 2, 4 and 6 are drawn in reduced scale.

1 Claim, 7 Drawing Sheets

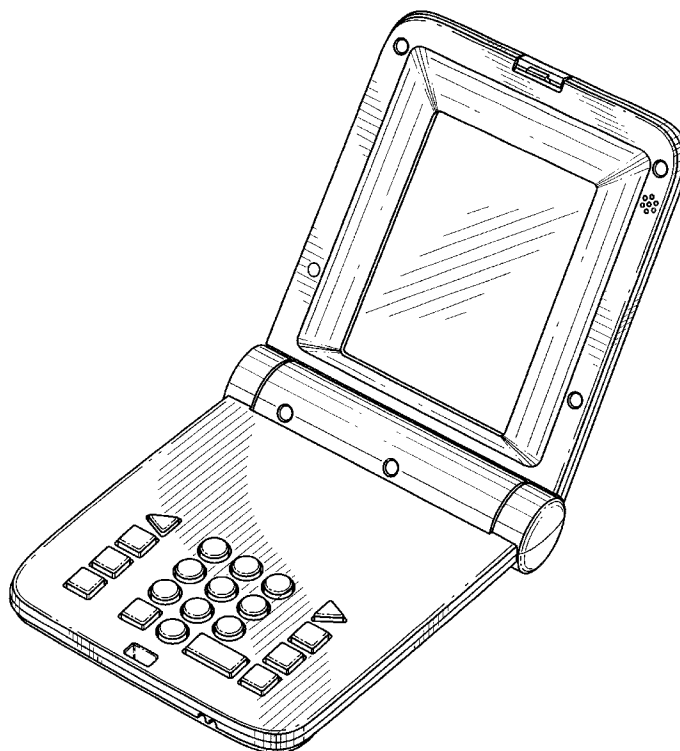
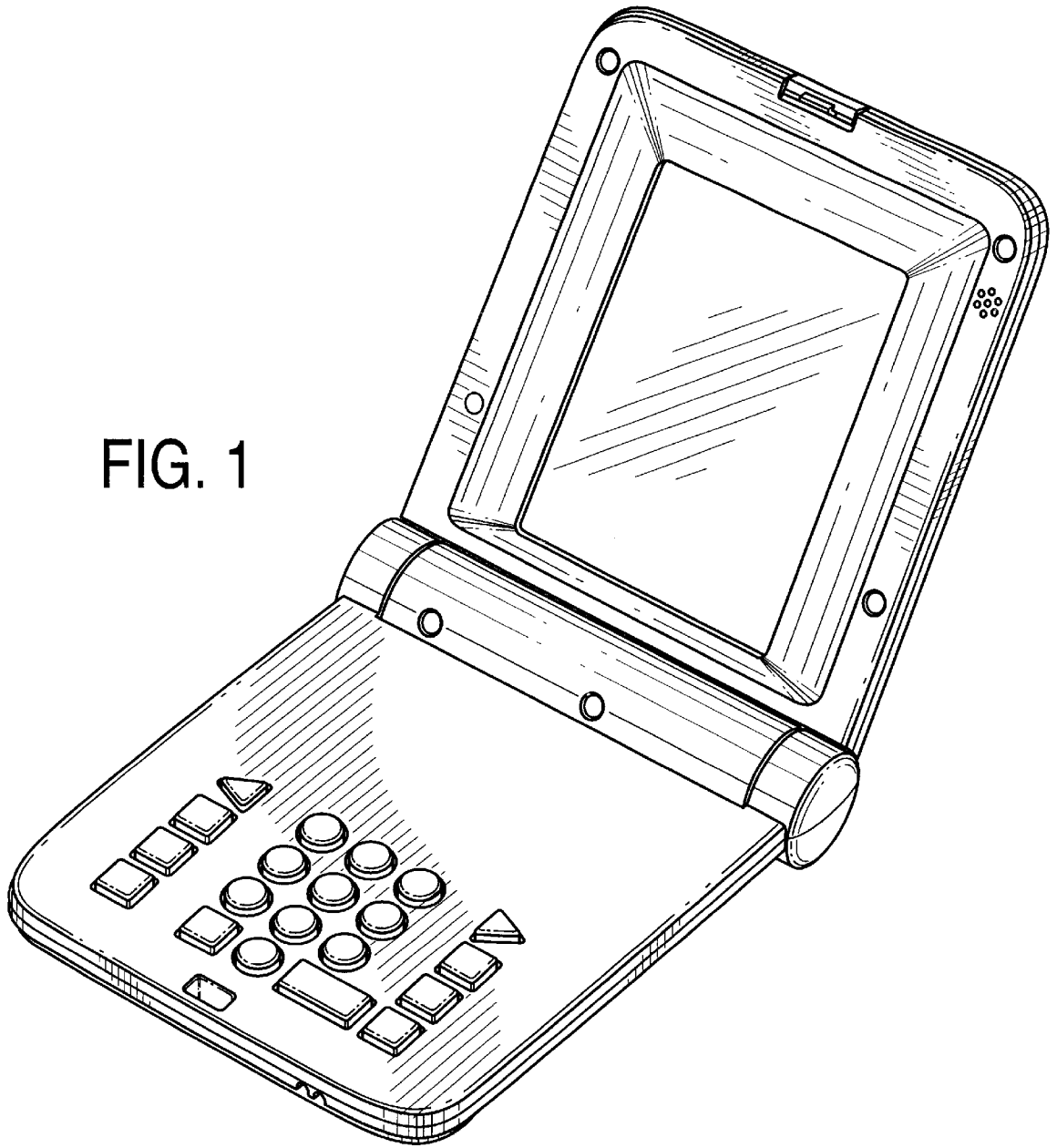

FIG. 1



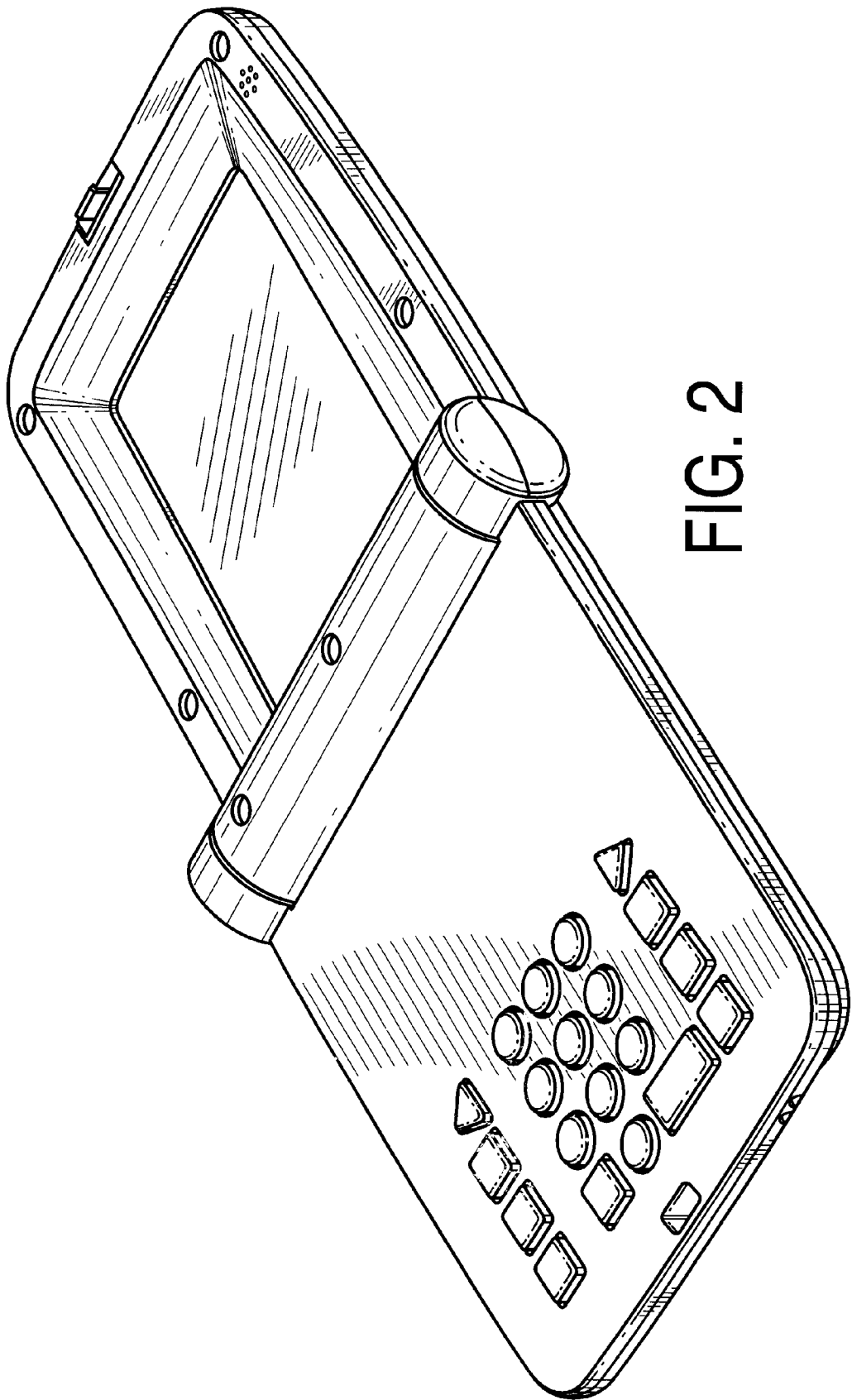

FIG. 2

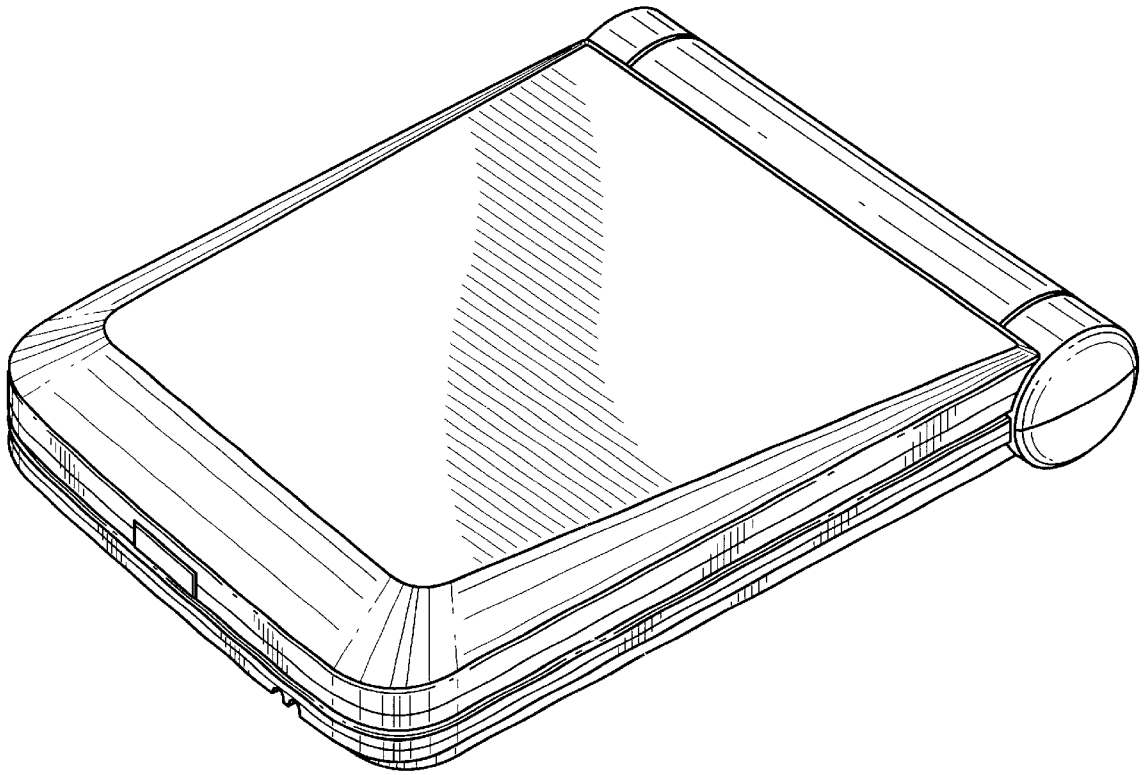

FIG. 3

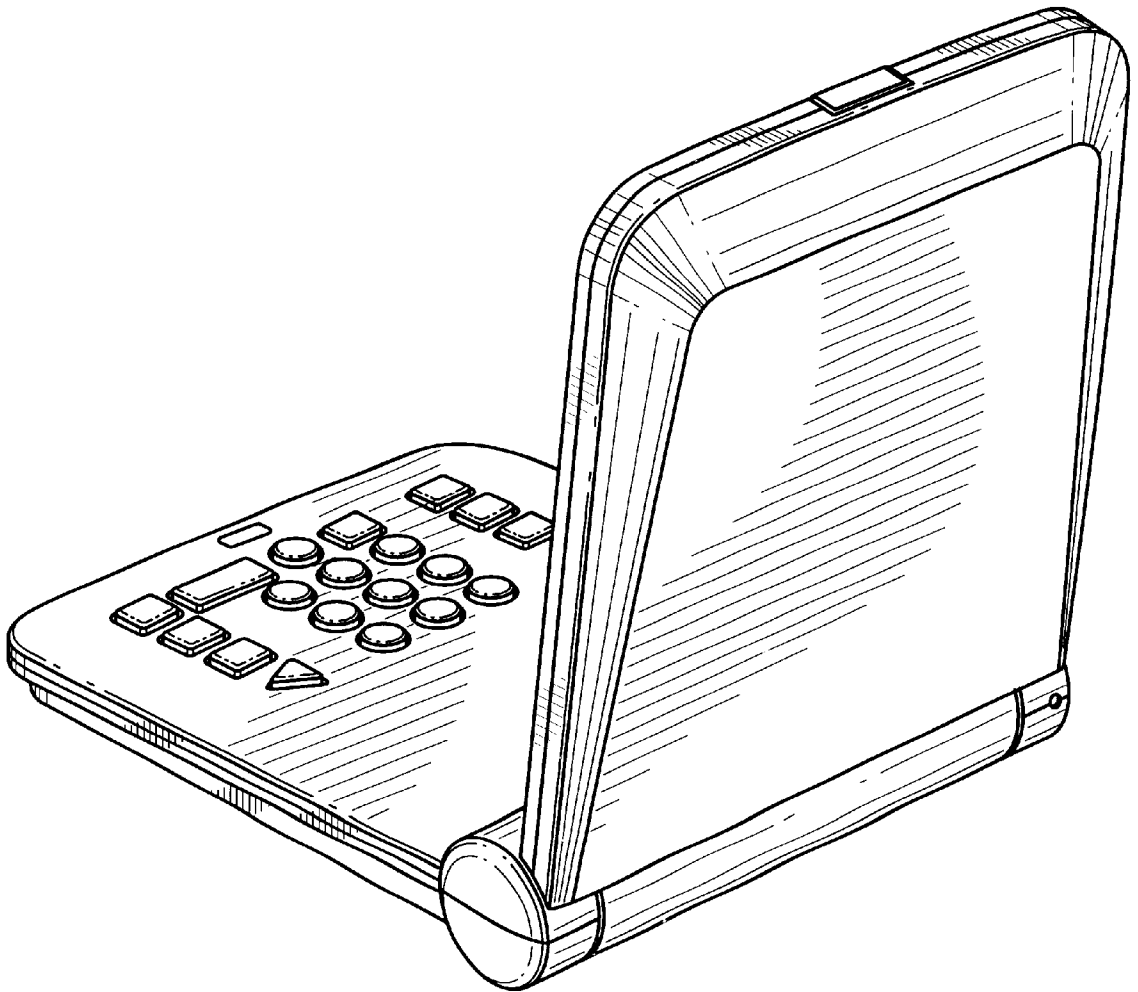

FIG. 4

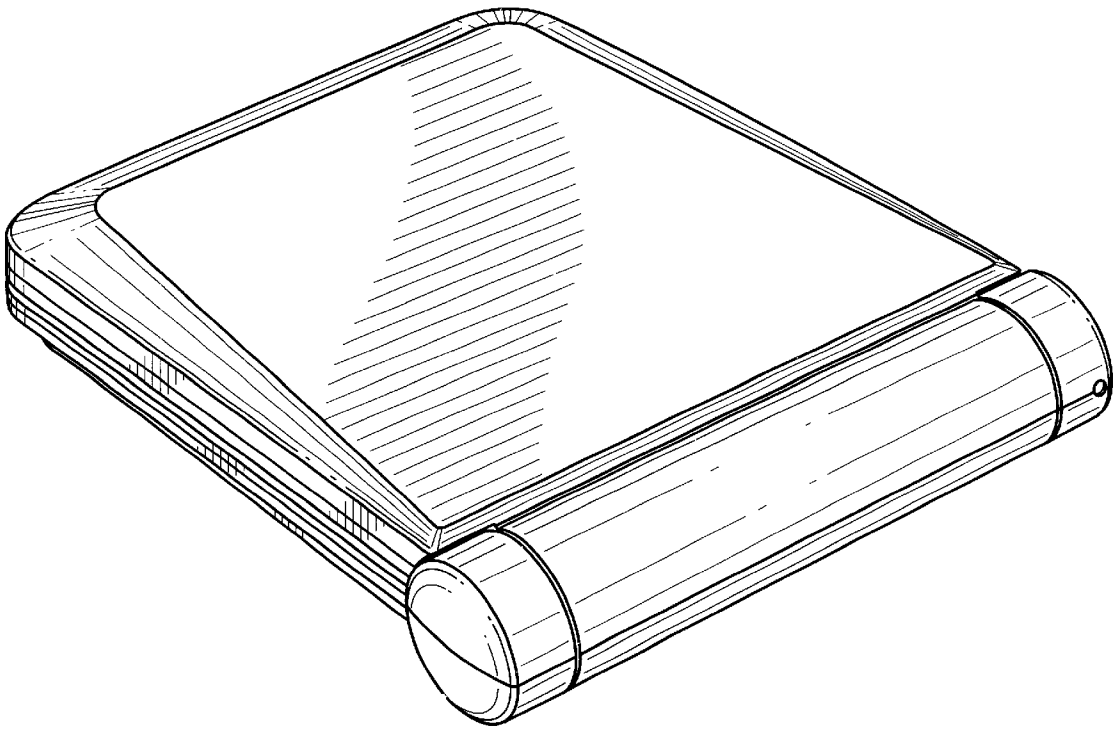

FIG. 5

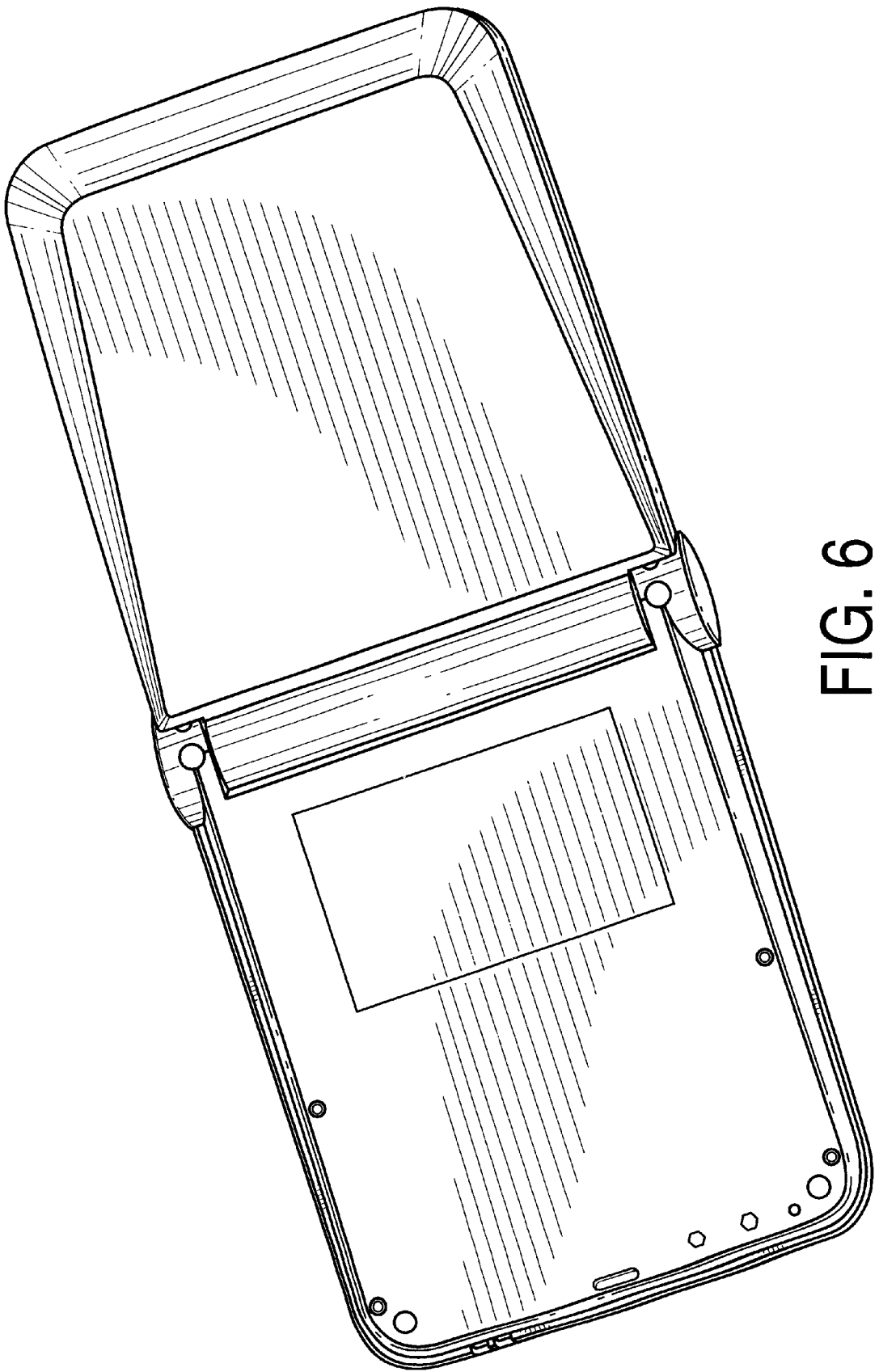

FIG. 6

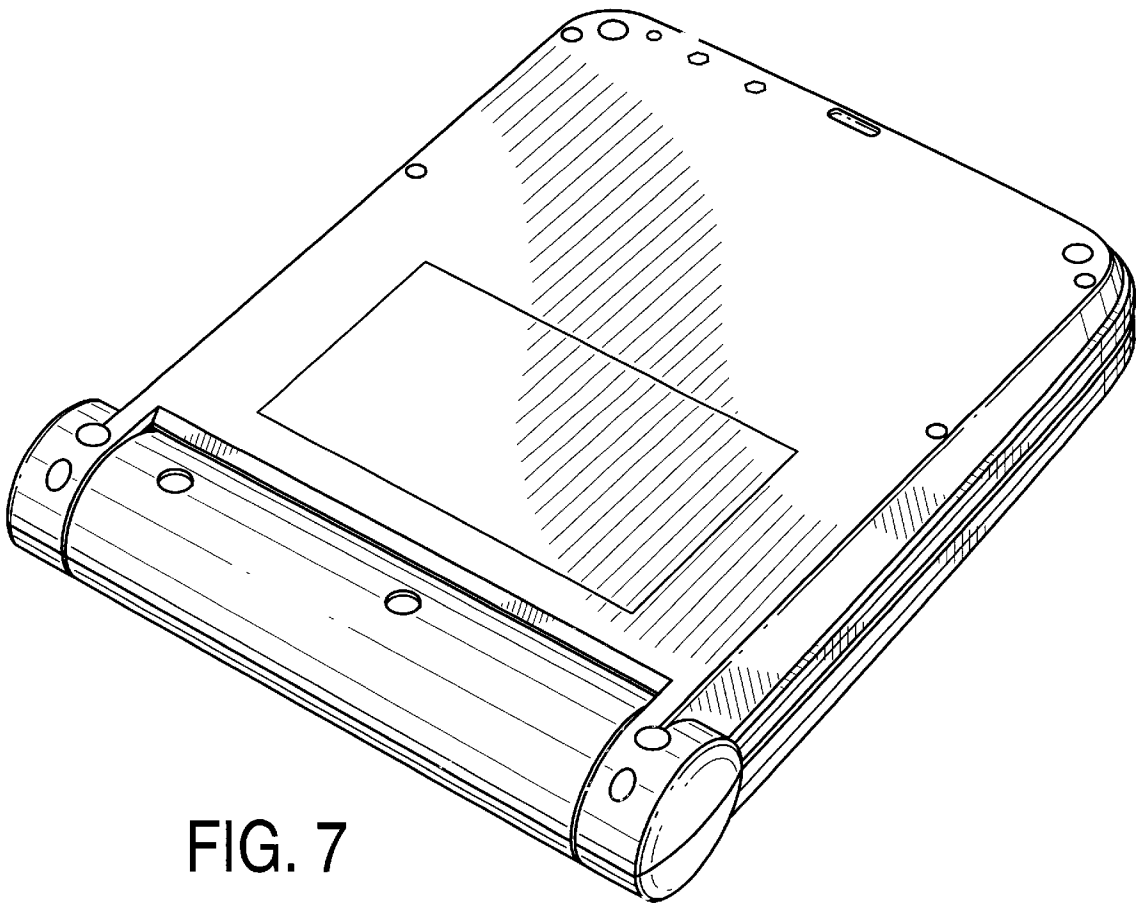

FIG. 7