

June 6, 1961

C. H. GOODWIN ET AL  
MECHANICAL FIBER OPENER FOR PRODUCING  
A SAMPLE SLIVER FOR TESTING PURPOSES

2,986,778

Filed Sept. 9, 1959

2 Sheets-Sheet 1

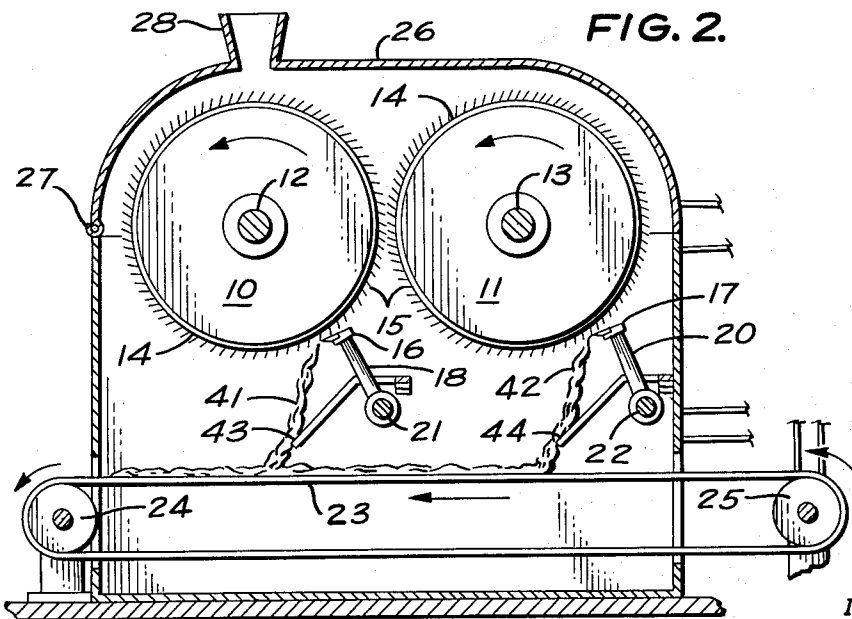
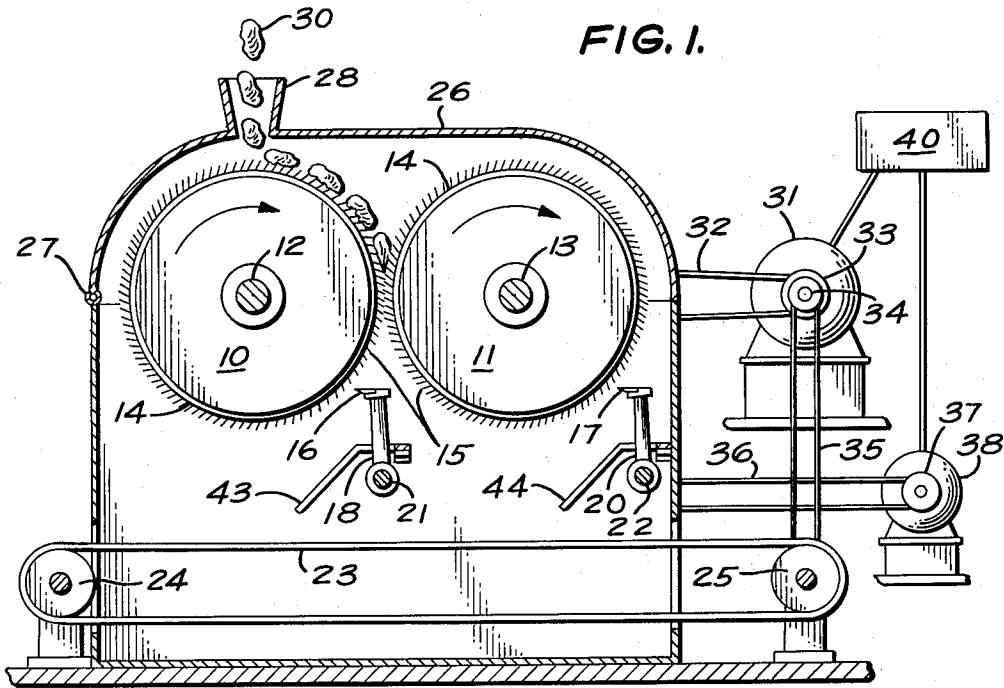

INVENTORS  
CHESTER H. GOODWIN  
WILLIAM R. McKELVY JR.  
BY *Stanley M. Tarter*

ATTORNEY

June 6, 1961

C. H. GOODWIN ET AL  
MECHANICAL FIBER OPENER FOR PRODUCING  
A SAMPLE SLIVER FOR TESTING PURPOSES

2,986,778

Filed Sept. 9, 1959

2 Sheets-Sheet 2

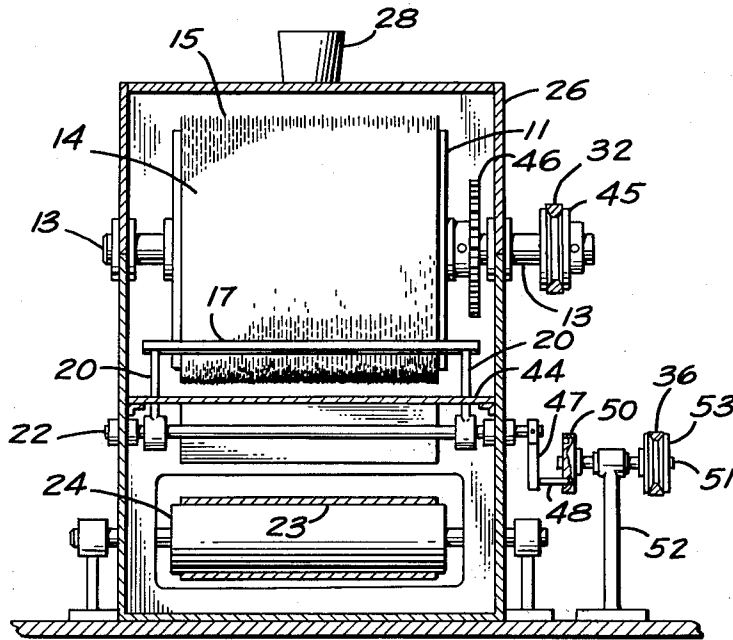

FIG. 3.

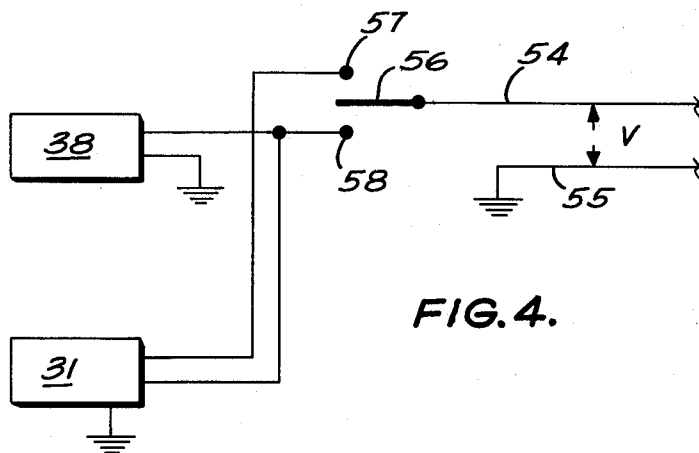

FIG. 4.

INVENTORS  
CHESTER H. GOODWIN  
WILLIAM R. McKELVY JR.  
BY

*Stanley M. Tarter*

ATTORNEY

1

2,986,778

**MECHANICAL FIBER OPENER FOR PRODUCING A SAMPLE SLIVER FOR TESTING PURPOSES**

Chester H. Goodwin, Decatur, Ala., and William R. McKelvy, Jr., Pensacola, Fla., assignors to The Chemstrand Corporation, Decatur, Ala., a corporation of Delaware

Filed Sept. 9, 1959, Ser. No. 838,935  
6 Claims. (Cl. 19-98)

The present invention relates to a mechanical fiber opener or carding machine for producing sample slivers from fibrous materials for testing purposes, and more particularly relates to a mechanical fiber opener or carding machine utilizing contact of such materials between rotating drums carrying projecting wire teeth on the peripheries thereof for producing sample slivers of uniform character for testing and evaluating purposes.

One of the most important processes in yarn manufacturing from staple fibers is known as a carding operation wherein the fibers being converted into yarn are rearranged and delivered in the form of a relatively thin and light-weight product identified in the art as a sliver. Generally speaking, carding is a combing operation in which fibrous materials are passed between a series of projecting wire teeth whereby the fibers are caused to lay to a greater extent parallel one to the other with an increased fiber-to-fiber spacial relationship. The carding of fibers to open same by the use of mechanical means is, of course, well known, such means usually consisting of cylinders of various sizes, the rotational speed and the relative rotational direction of which are varied, depending among other things upon the particular design of the carding machine.

In the manufacturing of synthetic fibers it is important to be able to determine in advance of shipment of such fibers to customers the quality of the fibers in regard to strength of thread produced therefrom, dyeability thereof, and other properties that may reflect or indicate their future behavior in thread or other end use product form. In addition, the determination is desirable to obtain an accurate picture as to the properties of natural fibers such as cotton, wool, and etc. In such instances it is necessary to open representative samples of these fibers by carding same. To this end it is, of course, possible to take a sample of fiber to be tested and to process it to a sliver or the like by employing production type equipment. Obviously, there are many disadvantages associated with such a method in that a considerable quantity of test fibers is required and therefore a substantial waste of fibers results when it is desired only to procure small samples of carded or opened fibers. Moreover, the cost of employing equipment used in production is obviously high.

While there have been suggested devices for making a test thread or test sliver from a fairly small quantity of fibers, such devices are complex in construction and expensive to build. As a result, the carding of small test quantities of fibers is conducted ordinarily by a hand operation employing hand instruments with projecting wire teeth, used in pairs to part, comb out, and set in order the staple fibers to be tested. As indicated above, the carded fibers or sliver samples are required for control testing of various fiber characteristics such as tensile strength and dye retention properties. Because of their use in testing and quality control evaluations, it is important that the carded fibers and sliver samples produced be of uniform character. Obviously, the hand carding operation for the production of fibrous slivers is not only tedious and time consuming but also results often in irregular samples as variations will occur owing to the various techniques used by different operators. Furthermore, the workers conducting the hand carding operation often suffer abrasions and

2

other injuries to their hands because of the handling of carding instruments containing the usual wirework.

The apparatus of the present invention comprises a device for mechanically opening staple fibers in an expeditious manner to form slivers or the like therefrom when it is desired to produce samples therefrom for testing and evaluating. Broadly speaking, the device of this invention provides means for carrying out a two-step operation wherein during the first step the sample of the staple fibers selected is subjected to a carding action whereby the fibers are opened and rearranged to lay in a more parallel relationship to one another by the engagement between two rotating cylinders having the peripheries covered with card clothing or the like. The cylinders move in a particular rotating relationship to each other. During the second step of the operation the direction of rotation of the cylinders is reversed, and the fibers are stripped therefrom by doffing means which are operable in response to the change in the direction of rotation of the cylinders.

Briefly stated, the apparatus of the present invention as illustrated herein comprises a pair of juxtaposed, rotatably mounted cylinders or drums, the peripheries of which are covered with card clothing or specially bent metallic wires, said drums being adapted to receive a sample of staple fibers and to subject same to a carding action. A pair of doffing combs associated with said drums to remove the fibers from each of the drums in the form of slivers and conveying means for collecting and delivering the produced slivers to an operator for further processing are provided. The drums are mounted for rotation in a first direction and for reversal of such rotational direction with the doffing means being operable in response to the reversal of direction. When the drums are rotated in the said first direction the wires projecting from the drums move in relation to each other so that the fibers in staple form are opened into individual relationship and laid in a more parallel arrangement as is normally accomplished by a carding action. Upon changing the direction of rotation of the drums the doffing means and the conveying means are actuated.

An object of this invention is to provide a device for preparing sliver samples of uniform character for subsequent testing from fibrous material including natural and synthetic staple fibers. It is further an object of this invention to provide a device which is capable of carding in an efficient manner very small quantities of fibers. Another object of this invention is to provide carding machines for mechanically opening small quantities of fibers by combing the fibers with a series of wire teeth on rotating cylinders or drums in a safe, economical, and rapid manner.

Further objects and advantages of the invention will become apparent to those skilled in the art as the disclosure of the invention is made in the following detailed description of a preferred embodiment thereof as illustrated in the accompanying drawing, wherein:

FIGURE 1 is a front elevational view of an embodiment of the mechanical fiber opener or card of the invention with the parts shown in position for the fiber opening step or the first operation referred to above with a long side of the housing of the opener removed for convenience of illustration;

FIGURE 2 is a similar elevational view with parts removed for convenience of illustration and shown in position for the operation of the doffing step or second operation referred to above;

FIGURE 3 is an end elevational view partly in section of the device illustrated in FIGURE 1; and

FIGURE 4 is a schematic view of an electrical control circuit employed so that the means for driving the doffing means and conveying means are operable in re-

sponse to the change of rotational direction of the cylinders or drums of the present carding machine.

In these various figures the same reference numerals designate like parts as is understood.

Referring now to the drawing for a better understanding of the invention, there are shown in FIGURE 1 cylindrical rollers or drums denoted by reference numerals 10 and 11, said drums being rotatably mounted on parallel shafts 12 and 13. Drums 10 and 11 are keyed to these shafts so that rotating movement of the shafts causes the respective drums to rotate. Reference numeral 14 indicates card clothings which are wrapped around and attached to the peripheries of said drums and consist of a foundation material usually made of textile material through which extend many fine, closely spaced wire teeth 15. As is shown, the card clothing foundation through which the card clothing staples or wire teeth 15 protrude is usually made of textile yarns and rubber. While it is preferred to employ a card clothing foundation for carrying the projecting wires since such an arrangement permits convenient changing of the wires, it will be appreciated that wire teeth 15 may be attached directly to the drums 10 and 11 without the use of card clothing foundation. As can be seen in the drawing the wire teeth 15 are disposed in closely spaced relationship. The wires are circumferentially inclined together from positions in alignment with the corresponding radial lines of the drums 10 and 11 but lie substantially in the corresponding radial planes thereof. It will be noted that the wires extend generally toward the direction of rotation of the drums as indicated by the arrows during the fiber opening or the first step referred to above. The drums carrying the card clothing are spaced slightly apart to permit minimum clearance consistent with the satisfactory performance of the apparatus and optimum clearance for the fiber sample being carded at the point of closest approach between the drums.

Beneath the drums 10 and 11, reference numerals 16 and 17 denote doffing combs which are oscillatably mounted on the free end of arms 18 and 20 respectively, said arms being pivotally supported by horizontally extending shafts 21 and 22 for oscillation within desired limits. These combs may be reciprocated from their inoperative position shown in FIGURE 1 to the operative or fiber removing position illustrated in FIGURE 2 where the combs are shown scalping or doffing accumulated fibers from the drums.

Reference numeral 23 represents a conveying means in the form of an endless belt conveyor mounted on rollers 24 and 25 for collecting and delivering the slivers of fibers removed from the carding drums 10 and 11. In this manner, the fiber samples opened and processed to slivers by the drums and stripped therefrom by the doffing means can be suitably accumulated and delivered to a point. Reference numeral 26 denotes a guard or housing which surrounds and encloses drums 10 and 11, the purpose of the housing being to provide means for shielding said drums during operation for protection of the operator and for other obvious safety reasons. Pivot point 27 at one end of the housing is provided for lifting and swinging same conveniently away when desired. Reference numeral 28 denotes a funnel-shaped chute or hopper for receiving the fiber sample 30 introduced and for delivering same onto and between the drums 10 and 11.

An electrical reversible motor or the like 31 is operatively connected with shafts 12 and 13 for imparting rotation thereto. Such connection may be provided, for example, by the use of belt 32 entrained on pulley 33 keyed to the drive shaft 34 of motor 31. Electric motor 31 also is operatively connected to conveying means 23 so that rollers 24 and 25 are actuated and driven simultaneously with the reversal of this motor. Belt 35 transmits power from motor 31 to roller 25 only during the doffing step or when the motor is operating in the direc-

tion opposite to that during the combing operation, the selective transmission of power being accomplished by a conventional arrangement such as by the use of a roller and gravity-pawl clutch adapted to run free in one direction and grip instantaneously in the other direction or other clutches adapted to do this.

One way of imparting oscillation to combs 16 and 17 is illustrated whereby belt 36 interconnects pulley 37 of motor 38 through a cam arrangement (see FIGURE 3). It is to be understood that the means for oscillating combs 16 and 17 as shown is by way of illustration since it is apparent that such oscillating motion can be accomplished by other means conventionally employed to obtain such motion. Motors 31 and 38 are operatively connected through means of control box 40 so that when reversible motor 31 is energized to rotate in the direction opposite to that during the combing operation motor 38 is activated, this electrical connection being described more fully below.

The operation of the embodiment of the invention will now be described. The fiber sample 30 is introduced through chute 28 and falls onto drum 10 moving in a clockwise direction, thereby conveying the sample between drums 10 and 11 which are coupled to rotate in unison at the same or different peripheral speeds in the direction as indicated by the arrows, whereby the fiber sample is opened by the action that takes place when the card clothings 14 carrying wire teeth 15 pass each other, with the wires of one clothing acting against the wires of the other. As indicated above, the drums are operated for minimum clearance and maximum opening of the textile fiber to be tested. That is to say, that the drums 10 and 11 are spaced preferably at the minimum distance which will permit clearance of the fibers and not permit contact of the wire teeth 15 which would deform same. Generally, the minimum distance between the ends of the wire teeth 15 is maintained at from 0.005 to 0.01 inch during the carding operation illustrated. In FIGURE 1 the doffing combs 16 and 17 are maintained in the inoperative position shown therein, and conveying means 23 is not in motion.

When the sample has had time to be subjected sufficiently to the carding action thereby to produce the desired degree of fiber opening, the drums 10 and 11 are stopped and the direction of rotation is reversed for the doffing step. At this instance doffing combs 16 and 17 become oscillated whereby they are moved from their normally inoperative positions to contact with the web of fibers surrounding the drums (FIGURE 2) so as to strip the web of fibers therefrom in the form of slivers. The oscillating movement of the doffing combs may be effected manually or such movement of the combs can be automatically actuated upon the reversal of the direction of rotation of the drums by conventional electrical or electro-mechanical means. As the doffing combs are moved, conveying means 23 is actuated to carry away slivers 41 and 42, as can be seen in FIGURE 2, which are deposited on it by the action of the doffing combs 16 and 17. For conveniently guiding these slivers to means 23 baffle plates 43 and 44 are provided upon which said slivers impinge.

Referring now in particular to FIGURE 3, it is to be noted that pulley 45 is adapted for reception of belt 32 and is keyed to shaft 13 for rotating drum 11. As shown, drums 10 and 11 are rotatable in unison by gearing including spur gear 46 keyed to shaft 13 and which meshes with a similar gear (not shown) keyed to shaft 12 through an intermediate gear, also not shown. However, it will be appreciated that shafts 12 and 13 may be interconnected for unison rotation by other means. Arms 20 that support doffing comb 17 are keyed to shaft 22, at one end of which a generally downwardly extending leg 47 also is keyed, thereby the arms, shaft and leg taking the form of a bellcrank lever which is given an oscillating motion. At the free end of leg 47 there is provided a freely rotatably mounted follower roll 48 adapted to

5

follow a groove in a positive motion face cam 50 or the periphery of an equivalent plate cam, which is mounted on shaft 51 supported by stand 52 and designed so that comb 17 is given an oscillating motion by the rotation of shaft 51. Pulley 53 is keyed to shaft 51 and is adapted for reception of belt 36. A similar cam arrangement (not shown) is provided for imparting oscillation to comb 16 and also is connected preferably with motor 38.

In FIGURE 4 there is shown a suitable electric circuit for energizing motors 31 and 38 so that upon reversal of the direction of rotation of drums 10 and 11 the conveying means 23 and doffing combs 16 and 17 are actuated. Lead wires 54 and 55 are connected to a suitable power source, with wire 54 leading to a switch 56 and with wire 55 leading to a ground connection. Switch 56 is operable between contacts 57 and 58 and to the off position shown in the drawing. When switch 56 is moved into engagement with contact 57 reversible motor 31 is energized so that the carding drums 10 and 11 are rotated in the required direction for carding action. In such case motor 38 is not energized; and hence, the pair of combs 16 and 17 is not actuated. Furthermore, conveying means 23 is not operated. Upon completion of the carding action the operator moves switch 56 out of engagement with contact 57 and into engagement with contact 58 whereby motor 38 is energized, as well as motor 31 which is now caused to be reversed. Hence, the direction of rotation of the drums is reversed; and the combs 16 and 17 and means 23 are actuated.

There are numerous advantages associated with the apparatus of the present invention. In practice it has been found that a 5 gram sample of commercially available acrylic staple fibers is processed to uniform slivers in approximately two minutes at about 30 revolutions per minute of the drums during the opening step, and 10 revolutions per minute in the opposite direction during the doffing step. A carding machine of relatively small construction is provided. For example, the drums may be 6 inches in length and 8 inches in diameter; and one can obtain a suitable sliver of fibrous material for testing purposes. Hence, the apparatus may be used conveniently in a fiber control laboratory with only a small amount of floor space being occupied by it. The apparatus is relatively simple in construction; and therefore, important savings in construction cost over the prior devices are realized. Other apparent advantages are associated with the apparatus described above.

It is obvious that there are many modifications that can be made in the apparatus illustrated without departing from the scope of the invention. For example, an electrical control system can be provided whereby the direction of rotation of the drums will be reversed after a predetermined period of time during the opening step at which instant the conveying means and doffing combs will be actuated and then the apparatus will be shut off after a predetermined period of time. Therefore, it will be understood, of course, that the foregoing disclosure relates to only a preferred embodiment of the invention and that it is intended to cover all changes and modifications of the example of the invention herein chosen for the purpose of the disclosure, which do not constitute departures from the spirit and scope of the invention as set forth in the appended claims.

What is claimed is:

1. An apparatus for subjecting a small amount of fibrous material to a carding action and for collecting the slivers made thereby, comprising a pair of rotatably mounted drums juxtaposed in axial parallel spaced relationship, a series of closely spaced wire teeth disposed along the peripheries of each of the drums and protruding outwardly therefrom and being slightly circumferentially inclined together from positions in alignment with the corresponding radial lines of said drums but lying substantially in the corresponding radial planes thereof,

6

an oscillatably mounted doffing comb associated with each of said drums and movable to and from fiber engaging doffing positions, means for rotating said drums in the direction of the inclination of said wire teeth and for rotating said drums in the opposite direction, means for collecting the slivers stripped from said drums by said combs, and means operable in response to the reversal of direction of rotation of said drums for actuating said combs into fiber engaging doffing positions so as to strip said fibrous material from said drums by the oscillating motion thereof after same has been subjected to the carding action produced by the rotation of said drums and the action of said wire teeth, the ends of the teeth of one drum being closely spaced from the ends of the teeth of the other drum in the area of closest approach thereof so that carding action takes place while the drums rotate in the direction of inclination of said wire teeth by the tendency of the teeth of one drum to move the fibrous material downwardly through the said area of closest approach and by the tendency of the teeth of the other drum to oppose the fibrous material from passing downwardly through the area of closest approach.

2. An apparatus for subjecting a small amount of fibrous material to a carding action and for collecting the slivers made thereby, comprising a pair of rotatably mounted drums juxtaposed in axial parallel spaced relationship, each drum peripherally carrying card clothing including card clothing foundation and a series of closely spaced wire teeth protruding outwardly therefrom and being slightly circumferentially inclined together from positions in alignment with the corresponding radial lines of said drums but lying substantially in the corresponding radial planes thereof, an oscillatably mounted doffing comb associated with each of said drums and movable to and from fiber engaging doffing positions, means for collecting the slivers stripped from said drums by said combs, means operable in response to the reversal of direction of rotation of said drums for actuating said combs into fiber engaging doffing positions so as to strip said fibrous material from said drums by the oscillating motion thereof after same has been subjected to the carding action produced by the rotation of said drums and the action of said wire teeth, and means for actuating said collecting means simultaneously with the actuation of said combs, the ends of the teeth of one drum being closely spaced from the ends of the teeth of the other drum in the area of closest approach thereof so that carding action takes place while the drums rotate in the direction of inclination of said wire teeth by the tendency of the teeth of one drum to move the fibrous material downwardly through the said area of closest approach and by the tendency of the teeth of the other drum to oppose the fibrous material from passing downwardly through the area of closest approach.

3. An apparatus for subjecting a small amount of fibrous material to a carding action and for collecting the slivers made thereby, comprising a pair of rotatably mounted drums juxtaposed in axial parallel spaced relationship, each drum peripherally carrying card clothing including card clothing foundations and a series of closely spaced wire teeth protruding outwardly therefrom and being slightly circumferentially inclined together from positions in alignment with the corresponding radial lines of said drums but lying substantially in the corresponding radial planes thereof, an oscillatably mounted doffing comb associated with each of said drums and disposed generally below said drums, the combs being movable to and from fiber engaging doffing positions, means for rotating said drums in the direction of inclination of said wire teeth and for rotating said drum in the opposite direction, means disposed below said drums and said combs for collecting the slivers stripped from said drums by

said combs, means operable in response to the reversal of direction of rotation of said drums for actuating said combs into fiber engaging doffing positions so as to strip said fibrous material from said drums by the oscillating motion thereof after same has been subjected to the carding action produced by the rotation of said drums and the action of said wire teeth, and means for actuating said collecting means simultaneously with the actuation of said combs, the ends of the teeth of one drum being closely spaced from the ends of the teeth of the other drum in the area of closest approach thereof so that carding action takes place while the drums rotate in the direction of inclination of said wire teeth by the tendency of the teeth of one drum to move the fibrous material downwardly through the said area of closest approach and by the tendency of the teeth of the other drum to oppose the fibrous material from passing downwardly through the area of closest approach.

4. An apparatus for subjecting a small amount of fibrous material to carding action and for collecting the slivers made thereby, comprising a pair of drums juxtaposed in axial parallel spaced relationship and mounted for unison rotation in one direction and then the other, each drum peripherally carrying card clothing including card clothing foundation and a series of closely spaced wire teeth protruding outwardly therefrom and being slightly circumferentially inclined together from positions in alignment with the corresponding radial lines of said drums but lying substantially in the corresponding radial planes thereof, an oscillatably mounted doffing comb associated with each of said drums and disposed generally below said drums, the combs being movable to and from fiber engaging doffing positions, means for rotating said drums in the direction of inclination of said wire teeth and for rotating said drums in the opposite direction, means disposed below said drums and said combs for collecting the slivers stripped from said drums by said combs, means operable in response to the reversal of direction of rotation of said drums for actuating said combs into fiber engaging doffing positions so as to strip said fibrous material from said drums by the oscillating motion thereof after same has been subjected to the carding action produced by the rotation of said drums and the action of said wire teeth, and means for actuating said collecting means simultaneously with the actuation of said combs, the ends of the teeth of one drum being closely spaced from the ends of the teeth of the other drum in the area of closest approach thereof so that carding action takes place while the drums rotate in the direction of inclination of said wire teeth by the tendency of the teeth of one drum to move the fibrous material downwardly through the said area of closest approach and by the tendency of the teeth of the other drum to oppose the fibrous material from passing downwardly through the area of closest approach.

5. An apparatus for subjecting a small amount of fibrous material to a carding action and for collecting the slivers made thereby, comprising a pair of drums juxtaposed in axial parallel spaced relationship and mounted for unison rotation in one direction and then the other, each drum peripherally carrying card clothing including card clothing foundation and a series of closely spaced wire teeth protruding outwardly therefrom and being slightly circumferentially inclined together from positions in alignment with the corresponding radial lines of said drums but lying substantially in the corresponding radial planes thereof, an oscillatably mounted doffing comb associated with each of said drums and disposed generally below said drums, the combs being movable to and from fiber engaging doffing positions, conveying

means disposed below said drums and said combs for collecting the slivers stripped from said drums by said combs, a reversible electric motor for rotating said drums in the direction of inclination of said wire teeth and for reversing the directional rotation of said drums, said motor connected with said conveying means to actuate same only when said drums rotate in the direction opposite to that during carding, and electrically powered means operable in response to the reversal of direction of rotation of said drums for actuating said combs into fiber engaging doffing positions so as to strip said fibrous material from said drums by the oscillating motion thereof after same has been subjected to the carding action produced by the rotation of said drums and the action of said wire teeth, the ends of the teeth of one drum being closely spaced from the ends of the teeth of the other drum in the area of closest approach thereof so that carding action takes place while the drums rotate in the direction of inclination of said wire teeth by the tendency of the teeth of one drum to move the fibrous material downwardly through the said area of closest approach and by the tendency of the teeth of the other drum to oppose the fibrous material from passing downwardly through the area of closest approach.

6. An apparatus for subjecting a small amount of fibrous material to carding action and for collecting the slivers made thereby, comprising a pair of drums juxtaposed in axial parallel spaced relationship and mounted for unison rotation in one direction and then the other, each drum peripherally carrying card clothing including card clothing foundation and a series of closely spaced wire teeth protruding outwardly therefrom and being slightly circumferentially inclined together from positions in alignment with the corresponding radial planes thereof, an oscillatably mounted doffing comb associated with each of said drums and disposed generally below said drums, the combs being movable to and from fiber engaging doffing positions, an endless belt conveyor disposed below said drums and said combs for collecting the slivers stripped from said drums by said combs, a reversible electric motor for supplying power to rotate said drums in the direction of inclination of said wire teeth and to reverse the directional rotation of said drums and for supplying power to said conveyor only when said drums rotate in the direction opposite to that during carding, and a second electric motor operable in response to the reversal of direction of rotation of said drums for supplying power to actuate said combs into said doffing positions so as to strip said fibrous material from said drums by the oscillating motion thereof after same has been subjected to the carding action produced by the rotation of said drums and the action of said wire teeth, the ends of the teeth of one drum being closely spaced from the ends of the teeth of the other drum in the area of closest approach thereof so that carding action takes place while the drums rotate in the direction of inclination of said wire teeth by the tendency of the teeth of one drum to move the fibrous material downwardly through the said area of closest approach and by the tendency of the teeth of the other drum to oppose the fibrous material from passing downwardly through the area of closest approach.

References Cited in the file of this patent

UNITED STATES PATENTS

2,167,808	Litty -----	Aug. 1, 1939
-----------	-------------	--------------

FOREIGN PATENTS

466,142	France -----	Feb. 21, 1914
---------	--------------	---------------