



(11) **EP 2 743 593 B1**

(12) **EUROPEAN PATENT SPECIFICATION**

(45) Date of publication and mention of the grant of the patent:
18.03.2020 Bulletin 2020/12

(51) Int Cl.:
F24C 15/32^(2006.01)

(21) Application number: **13196639.2**

(22) Date of filing: **11.12.2013**

(54) **Household cooking oven**

Haushaltsbackofen

Four de cuisson domestique

(84) Designated Contracting States:
AL AT BE BG CH CY CZ DE DK EE ES FI FR GB GR HR HU IE IS IT LI LT LU LV MC MK MT NL NO PL PT RO RS SE SI SK SM TR

(30) Priority: **14.12.2012 IT TO20121075**

(43) Date of publication of application:
18.06.2014 Bulletin 2014/25

(73) Proprietor: **Whirlpool EMEA S.p.A.**
20016 Pero (MI) (IT)

(72) Inventor: **Colozzo, Vincenzo Giuseppe**
06023 Gualdo Tadino (PG) (IT)

(74) Representative: **Spina, Alessandro et al**
Whirlpool EMEA SpA
Via Carlo Pisacane, 1
20016 Pero (MI) (IT)

(56) References cited:
EP-A1- 2 012 066 EP-A1- 2 735 806
DE-A1-102008 042 473 GB-A- 631 323

EP 2 743 593 B1

Note: Within nine months of the publication of the mention of the grant of the European patent in the European Patent Bulletin, any person may give notice to the European Patent Office of opposition to that patent, in accordance with the Implementing Regulations. Notice of opposition shall not be deemed to have been filed until the opposition fee has been paid. (Art. 99(1) European Patent Convention).

Description

Field of the invention

[0001] The present invention relates to cooking ovens and has been developed particularly with reference to convection cooking ovens.

Technical State of the art

[0002] The domestic ovens for cooking foods typically comprise a bearing structure, which is associated to a muffle and a front door which closes the muffle frontally. Within ventilated ovens, inside the muffle there's a metal bulkhead, formed by a metal sheet, facing to the rear wall of the muffle. This bulkhead divides the internal cavity of the muffle in a front cooking chamber, which extends between the door and the bulkhead, and a rear air distribution chamber, which extends between the bulkhead and the rear wall of the muffle.

In the cooking chamber there is one or more shelves generally positioned at different heights, where food containers can be placed, to define different levels of cooking.

In the air distribution chamber is operatively arranged at least one heating resistance, which usually has a circular shape, as well as a fan, that is usually positioned in the area circumscribed by the resistance.

The fan impeller is usually a centrifugal one and, the distribution chamber wherein it's located has an output section, for the airflow to the cooking chamber, as well as an input section. The output section usually includes a plurality of passageways, which are normally in peripheral positions with respect to the distribution chamber, generally outlined between the bulkhead and the rear or side wall of the muffle.

More particularly, in most of the known solutions, the bulkhead has a smaller size compared to the size of the rear wall of the muffle and has a folded back edge, which is shaped in order to define the areas for the anchorage of the bulkhead to the rear wall of the muffle. The edge is cut, or otherwise shaped, also in order to outline the above mentioned peripheral airflow routes.

The input airflow section of the distribution chamber is instead located in a central area of the bulkhead, configured substantially as a grid - usually by means of a multitude of holes close to each other - located in front of the fan impeller.

In this way the air is heated by the electric resistance and is pushed towards the air output devices of the distribution chamber, to flow substantially along the side walls of the muffle, toward the cooking chamber. Thanks to the action of the fan, the same air is sucked towards the central zone, to the grid of the bulkhead, in order to heat, by convection, foods that are on the shelf or shelves arranged within the cooking chamber; this "exhausted" air, which has heated the food, then, returns to the distribution chamber to be reheated and fed back into the cooking

chamber.

[0003] In the previously described ovens the intermediate bulkhead of the muffle has essentially the task to direct the airflow inside the cavity of the muffle, using the grid that is normally dimensioned to ensure sufficient suction of "exhausted" air and prevent the risk of user injury.

[0004] The cooking method resulting from this air distribution system depends mainly on the airflow of return - namely the sucked airflow in the central area of the bulkhead - that invests the foods placed in the oven at any level of shelves. The result is that the cooking is possible due to a quite chaotic movement of the airflow, which depends on the geometric shape of the grid of the bulkhead and on the direction of rotation of the fan impeller.

[0005] Document DE 10 2008 042473 A1 discloses a cooking chamber unit for forming two cooking support regions and two gas outlet devices comprising two gas outlet units that open in to the support regions, respectively.

[0006] EP 2735806 A1 discloses a household cooking oven provided with a bulkhead, wherein the frontal inlet comprises a plurality of circular openings distributed along the longitudinal direction.

Purpose and abstracts of the invention

[0007] The main purpose of the present invention is essentially to provide a ventilated cooking oven in which the distribution of the air, in the cooking chamber, takes place with a controlled method, particularly in order to obtain a substantially symmetrical and/ or balanced distribution among the different levels of cooking.

[0008] Additional scopes, together with the above one, which will result more clear in the following, are achieved by means of the present invention, by a household cooking oven with the characteristics described in the attached claims, which form an integral part of the technical teaching provided herein with reference to the invention.

Brief Description of Drawings

[0009] Further objects, features and advantages of the invention will appear from the following description and from the attached figures, provided for purely illustrative and not limiting purposes, in which:

- Figure 1 is a schematic view in front elevation of a domestic cooking oven according to the invention;
- Figure 2 is a lateral section, partial and schematic, of the oven of Figure 1;
- Figure 3 is a partially exploded view and sectional view of a muffle of Figure 1;
- Figures 4, 5 and 6 are schematic views of a bulkhead of the muffle of Figure 3, respectively, frontal section,

lateral section and in perspective;

- Figure 7 is a schematic front elevation of an oven according to the invention, with about half of its front door removed;
- Figure 8 is a view similar to that of Figure 5, relating to a possible variant of the invention;
- Figure 9 is a view similar to that of Figure 5, relating to a further possible embodiment of the invention.

Description of the preferred embodiment of the invention

[0010] The reference to "one embodiment" in the context of this description is to indicate that a particular configuration, structure or characteristic described in relation with the invention is included in at least one oven embodiment. So that, phrases such as "in one embodiment" and similar that may be present in different points of this description, are not necessarily referred to the same implementation of this oven invention. Furthermore, particular conformations, structures, or characteristics may be combined in any suitable manner in one or more embodiments, also different from those depicted. The references used herein are for convenience only and therefore do not define the scope of protection or the scope of the embodiments. Furthermore, the oven will be described below limited to the elements necessary to the understanding of the invention, assuming that the oven itself includes all other components normally known and necessary for its operation.

[0011] In Figures 1 and 2, number 1 indicates a household cooking oven according to the invention. The oven has a bearing structure or casing, shown with 2, in the front of which there is a control panel 3. In the front of the casing 2 is also hinged, particularly in the lower edge, a door 4, provided with a handle 4a.

[0012] Inside the casing 2 is housed a muffle, partially visible in Figures 2 and 3, where it is indicated overall by 5. The muffle 5 has a rigid metallic body, having two side walls, a bottom wall, a top wall and a rear wall; in figure 2 is represented the rear wall, denoted by 5a, while Figure 3 shows partially the lower wall 5b and the upper 5c, and one of the side walls 5d. The muffle 5 is preferably protected by a layer of insulation, already known and not represented.

[0013] The muffle 5 defines a cavity, that can be frontally opened and closed by the door 4, in which is present a rear bulkhead 10, in a position generally facing the rear wall of the muffle 5a: in this way the bulkhead 10 divides the inside of the muffle 5 in a front cooking chamber that extends between the door 4 and the bulkhead 10, and a rear air-distribution chamber that extends between the bulkhead 10 and the rear wall of the muffle 5a.

[0014] In correspondence to the side walls 5d of the muffle are provided generic supports to hang up removable shelves, for example trays, grids or drips. In the

illustrated embodiment - see in particular figure 2 - the supports consist in guides 6 shaped on the side walls of the muffle 5d, but in alternative embodiments, guides having a similar function can be represented by added grid, applied to the side walls 5d. In the guides 6 of the two opposite side walls 5d of the muffle are inserted in a sliding manner the edges of these shelves, one of these - here represented by an oven baking tray - is shown with number 7 in Figures 2, 3 and 7. With the symbol 8a is represented a generic cooking vessel, in the example a baking pan, having a lateral size dimension smaller than the distance between the two side walls of the 5d muffle: this container 8a will be placed in a cooking shelf - schematically represented only in Figures 2 and 7, where it is shown with 8 - having an appropriate size to engage its respective guides 6 of the lateral walls 5d. The guides 6 are defined at different heights, in order to arrange in the cooking chamber a plurality of different positions for different levels of cooking: as a simple example, this different cooking levels are shown in Figure 7 with the letters from "A" to "E", from the bottom upwards.

[0015] The cooking chamber is preferably but not necessarily equipped with suitable heating elements. In the exemplified embodiment are provided two electric resistances, or grill (broil) resistance - represented only in figure 3, where one of them is indicated with 9. The resistance 9, usable particularly to cook food in the cooking chamber by intense radiant heat from the upper broil element, is placed within the muffle 5, on its upper wall 5b.

[0016] In the air distribution chamber defined between the rear wall of the muffle 5a and the bulkhead 10 are operatively arranged at least one electrical heating resistance 11 and the impeller 12 of a fan, particularly a centrifugal fan with axial suction and radial delivery. The fan motor, marked with 13 in figure 2, is assembled outside the muffle 5, behind its rear wall 5a, with its drive shaft passing through a slot in the rear wall. The impeller 12 rotates preferably within the region where the resistance 11 is placed, here defined as "rear", which has preferably a shape at least partially annular.

[0017] Preferably, the peripheral profile of the bulkhead 10 has perimeter size generally lower than that of the rear wall of the muffle 5a, as seen for example in Figures 2, 3 and 7. In this way, for instance, the assembly of the resistances 9 does not necessarily imply they pass through holes or breaks in the bulkhead 10. The different sizes between the perimeter wall 10 and rear wall 5a also allow, for example, to install a lamp directly on this last one - indicated with 14 only in Figure 3 - to light up inside when necessary the cooking chamber.

[0018] According to the traditional operating principles of the ventilated ovens, the distribution chamber has an outlet section for the delivery of the air, through the fan impeller 12, which forcibly inflates the air previously heated by the resistance 11 in the cooking chamber and an inlet section or recycling, through the impeller 12, which can draw air from the cooking chamber and then forces it back inside the same cooking chamber through

the outlet section. This air is later again heated by the resistance 11.

As later clear, the outlet section comprises, similarly to the working principles of ventilated ovens, air passageways in generally peripheral positions of the air distribution chamber. On the other hand, the inlet section of the air distribution chamber of the oven 1 is not formed with a traditional grid of holes or similar shapes in the wall of the bulkhead 10.

In fact according to the main invention characteristic, the inlet section comprises an air-suction cavity or chamber in the bulkhead 10. This air-suction cavity, 20 in Figures 2 and 3, has at least one inlet in the bulkhead 10 toward the cooking chamber and at least one outlet in the rear bulkhead facing towards the fan impeller 12 .

[0019] In a preferred embodiment, the bulkhead 10 has a structure partially box-shaped to easier deliver the air-flow in the internal cavity 20. For this purpose, much preferably, the bulkhead 10 consists of at least two parts joined to get a cavity chamber, where the two parts in question can be welded, or stapled or otherwise made integral with each other (for example with screws or similar) . For example, referring also to Figures 4-6, for some implementations, the bulkhead consists of two parts: the rear part 10a and the front one 10b, consisting of metal plates sheared and shaped, welded together.

[0020] The rear part 10a defines at least one outlet 21, preferably in a central region that is generally flat. The periphery of the part 10a is instead preferably shaped in order to create areas for the complete anchorage of the bulkhead 10 to the rear wall 5a of the muffle. In the depicted example the peripheral part 10a, that is generally preferably bent backwards, defines an upper zone 10a1 for anchoring, for example with screws, of the bulkhead 10 to the wall 5a, and a lower zone 10a2 for the support of the bulkhead 10 to the wall 5a. (of course, you can also fix the bulkhead 10 to the 5a wall in its lower parts). Returning to the already illustrated example, the peripheral profile of the part 10a is shaped, in its allocation 10a3, between the area 10a1 and the area 10a2, in order to create, together with the rear wall of the muffle 5a, passageway routes for delivery of the air outlet and then inlet from air-distribution chamber.

[0021] For this purpose, in the example, the edge regions 10a3 are sliced in a way to lie along a vertical plane that is generally in parallel position far-between from a plane defined by the edges of the areas 10a1 and 10a2, as shown for example in Figure 5; in this way, when the bulkhead 10 is assembled inside the muffle 5, between the edge of the regions 10a3 and the front surface of the rear wall 5a are defined the above mentioned peripheral airflow passageways at least partially implementing the outlet section of the distribution chamber: these passageways are marked with 22 in the figures 3-6.

[0022] Still with reference to the oven exemplified embodiment, as clearly visible in figure 5, the front part 10b of the bulkhead 10 is shaped in order to define the cavity 20, together with the rear part 10a. For this purpose, in

the example, the part 10b has a C shaped section.

[0023] According to the invention, at least a cavity inlet 20 comprises a plurality of longitudinally extended inlet openings. These inlet openings are shown in images 4-6 with symbols from 23a to 23e but later, in other drawings, where not strictly needed from description, they will be all referred to as 23.

[0024] In the preferred embodiment, the inlet openings 23 comprises a plurality of slits which extend substantially horizontally between two opposite lateral regions of the bulkhead 10 or the air-suction cavity 20, with such a slits that extend at different heights. Still with reference to the oven, one or more inlet openings 23 each have a mouth defined by a respective lip 24 projecting from the front 10b of the bulkhead 10 towards the cooking chamber. However, it has to be pointed out that the presence of the lips inlet 24 is merely optional and does not constitute an essential feature for the implementation of the invention. In the example shown, therefore, the openings 23 with its lips 24 are defined from the front 10b of the bulkhead 10.

In the example each inlet opening 23 extends in length between those two opposite lateral regions of the front of the bulkhead 10 or air-suction cavity 20, in a continuous way; in possible but not represented embodiment, however, one or more of the openings 23 can be interrupted and be constituted by a plurality of individual openings or slits horizontally aligned. The openings 23 may have same or may have different passage sections. In the example, the openings 23a-23c have substantially the same passage section, whereas, the openings 23d and 23e, have smaller passage section, being them shorter than the other.

In one embodiment at least a pair of openings or slits are closer to each other with respect to other two slits in the plurality of ovens. The presence of two openings closer to each other allows to produce a higher heat air flow by convection to the corresponding food in cooking chamber and so a faster cooking at this level. Referring to the Figures 1-7 of the household cooking oven, this is the case of the openings 23d and 23e which are located in the top side of the air-suction cavity or chamber 20.

As already stated, the rear part 10a of the bulkhead 10 comprises at least one outlet opening 21 of the air-suction cavity or chamber 20. The outlet section of the cavity may consist in a grid of holes or only in a grid portion 10a. However, the preferred embodiment is provided with a single opening 21, preferably essentially coaxial to a rotation axis of the fan impeller 12 . The single opening 21 has essentially elliptical profile with a vertical major axis. According to the invention, a substantially elliptical opening 21 provides a larger passageway section than a circular one without affecting the performance of the impeller 12. Furthermore, with an elliptical profile the outlet 21 includes two areas (upper and lower respect to the axis of the impeller 12) where the inlet section is bigger, and two areas (the lateral areas respect to the axis of the impeller 12) which help the compression of the fluid: the

combination of these geometries allows to obtain an outlet speed of the air from the impeller 12 in a more higher and homogeneous way compared to a circular opening.

[0025] In the preferred embodiment, like the represented one, the back portion 10a of the bulkhead 10 has a projecting lip 21a oriented toward the impeller 12 of the fan, delimiting the at least one outlet 21. The lip 21a provides a continuity radius that allows to get closer the air suction section represented by the outlet 21 and the front face of the fan 12, improving its efficiency. In a preferred embodiment the air suction cavity 20 has a peripheral profile with two opposite sides having an alternation of crest and valley (20a, 20b) at intermediate heights respect to the inlet openings 23. As can be seen in Figure 6 example, in this way, the opposite sides of the peripheral profile of the cavity 20 have alternating crests and valleys, some of which indicated with 20a and 20b, where the inlet opening 23 have opposite end regions each extending within the boundary of a respective crest. Said valleys allow to guide the air flow within the cavity 20 and meantime avoid the presence of dead volumes that could affect the intake air flow from the impeller 12. In a preferred embodiment, the bulkhead 10 includes some deflector elements which are part of the outlet section of the air distribution chamber, whose function is correcting the direction of air flow towards the zone of interest, specifically based on the inertia of motion generated by the impeller. Preferably, at least two deflectors 15 are provided in the back portion 10a of the bulkhead 10, in opposed zones of its upper portion. Preferably the two deflectors 15 have a not speculate positioning: in the example they have a curved profile, roughly arc of a circle, and are arranged one with the concavity facing upwards (the deflector 15 to the right of Figure 4) and the other one with the concavity facing downwards (the deflector 15 to the left of Figure 4), in order to address properly the supply air flow of the impeller 12. Deflector's positioning may vary in shape and number according to the shape and direction of rotation of the impeller 12: the represented example refers to an impeller 12 rotating in a clockwise direction.

[0026] As previously said the cooking chamber has at two opposite lateral walls 5d of the muffle 5, guides 6 to support removable shelves 7,8 in a plurality of different height positions, or cooking levels, schematically referred as A-E in figure 7. In a particularly advantageous embodiment of the invention, the inlet openings 23 of the air-suction cavity 20 and the guides 6 being in such position that, in at least one of said height position A-E, a shelf 7,8 extends at an height that is intermediate to two said inlet openings 23. Such an example is represented in Figure 7, in relation to the shelf 8 which occupies the cooking position identified by the letter D: in such position, the shelf 8 (and also the respective container 8a) is located at a level intermediate between the openings 23c and 23d-23e. In the example, the drip pan 7 occupies the position B, lying substantially opposite the lowest opening 23a of the bulkhead 10: this is substantially due

to the fact that the drip pan 7 is higher than the shelf 9: it will be appreciated, however, that placing the shelf 8 in position B in place of the dripping pan 7, it will at an intermediate level between the openings 23a and 23b.

[0027] A possible variation of what stated above could even be to consider at least one opening 23 in correspondence to the peripheral profile of the air-suction cavity 20, for instance its upper or lower side. Figure 8 represents such a case, where the reference numbers are the same as in the previous figures, to identify elements technically equivalent to the ones described above. In this case, the inlet section of the air distribution chamber or cavity includes an additional opening 23f, whose shape may be similar to the openings 23a-23c, provided in correspondence of the lower side of the peripheral profile of cavity 20. In such a way, with a dripping pan 7 placed exactly at the cooking level B, there will be an effect of air suction even below the dripping pan itself, with a consequent warming effect from bottom. It should be reminded that when a single level cooking is performed (that is only a shelf 8 is present inside the muffle) food is typically not positioned in the very lower part. Therefore, positions A and B are commonly used for "multilevel" cooking, namely for 3 and 2 levels. Also, positions A and B can be used in case food and/or containers are bulky in the height dimension.

[0028] Openings 23 could be substantially equidistant in height, as depicted for openings 23a-23d (not for 23d-23e), but, in alternative implementations, their mutual distance could be even different: generally speaking, the height and/or the mutual distance of openings 23 is determined by cooking levels (A-E) defined in the cooking chamber and by typology and number of convection cooking allowed to the oven 1 user. Figure 9 shows, as an example, a different position for openings 23 compared to figures 5 and 8, where there is not opening 23a and the highest opening 23e is provided in correspondence to the upper side of the peripheral profile of cavity 20.

[0029] In the oven according to the invention, the air flow forced by the impeller 12 is more controlled than in traditional solutions. The air-suction generated by the impeller is influenced by the presence of the cavity 20: in other words, air-suction isn't a directly from the cooking chamber, but through the cavity 20: the negative pressure that occurs within the cavity, by means of openings 23, generates the air recycling from the cooking chamber. Openings 23 allow the air recycling from well identified zones of the bulkhead 10, in order to create respective zones of controlled heating, with a substantially symmetrical and balanced distribution among the different cooking levels, as defined by tracks 6. In the traditional known architectures the air flow is not controlled, neither in blowing nor in suction.

[0030] According to the invention, then, the air-suction cavity 20 creates a volume or storage unit from where the impeller 12 can suck without any impact onto the air flow within the cooking chamber. The cavity could even

be extended beyond the air-suction zone of impeller 12; above all, the air-flow sucked by the cooking chamber into the distribution chamber is essentially determined by the shape of the bulkhead 10, namely by its openings 23, not by impeller 12.

[0031] Openings 23 allow the air suction, by creating a kind of layers of hot air, which in turn transfer the heat to the food under cooking. Provided openings 23 are independent each other, they can assure a multi-level cooking: when 2 shelves are put inside the oven, actually resulting into a 2-levels cooking, each of them is supplied by at least two openings 23, with related air flows, below and above each shelf.

[0032] As already mentioned, in the alternative embodiment described in figure 8, openings 23 are even extended to the lower part of bulkhead 10, in order to generate a retrieving effect even below the cooking level B. Possibly, by accurately dimensioning the cavity 20 and the related lowest inlet opening (for instance the 23f), it will be possible to obtain a hot air cushion even below the lower cooking level (level A, in the picture); in such a case, according to the invention, oven 1 could even be deprived of heating resistance below the lower wall 5b of muffle 5.

[0033] As per the above descriptions, the invention's main characteristics, as well as their benefits, are clear. It is clear that the household cooking oven described herein for exemplification purposes can be subjected to numerous variants by a man skilled in the art without departing from the scopes of the invention as defined in the attached claims

[0034] Being known that cooking is the product's result of temperature and air speed (heating amount transferred by convection), then, by properly dimensioning openings 23, the heating will be equally transferred to the food over the different cooking levels, resulting into an unvarying cooking time and homogeneity. Also, as described above, different openings 23 can have different passage sections, and then different air flow rate, allowing to differentiate cooking times over different levels A-E.

Claims

1. A household cooking oven (1), comprising a bearing structure (2), a muffle (5) and a front door (4) to close frontally the muffle (5), in the muffle (5) there being present a bulkhead (10) generally facing a rear muffle wall (5a), the bulkhead (10) dividing the inside of the muffle (5) in a front cooking chamber, that extends between the door (4) and the bulkhead (10), and a rear air-distribution chamber, that extends between the bulkhead (10) and the rear muffle wall (5a), wherein in the air-distribution chamber there are operatively arranged at least one heating resistance (11) and an impeller (12) of a centrifugal fan (12, 13), wherein the air-distribution chamber has an outlet

section (15, 22) for delivery of air to the cooking chamber and an inlet section (20-23) for intake of air from the cooking chamber, the outlet section (15, 22) comprising passageways (22) in generally peripheral positions of the air-distribution chamber, wherein the inlet section (20-23) comprises an air-suction cavity or chamber (20) defined in the bulkhead (10), the air-suction cavity (20) having at least one inlet (23), defined in a front (10b) of the bulkhead (10) and oriented towards the cooking chamber, and at least one outlet (21), defined in a back (10a) of the bulkhead (10) and oriented towards the impeller (12) of the fan (12, 13), the oven being **characterized in that** the at least one outlet (21) has a substantially elliptical profile with substantially vertical major axis, and wherein the at least one inlet (23) comprises a plurality of longitudinally extended inlet openings.

2. The household cooking oven according to claim 1, wherein the at least one outlet comprises a single opening (21), preferably substantially coaxial to a rotation axis of the impeller (12) of the fan (12, 13).
3. The household cooking oven according to claim 2, wherein the inlet openings comprise a plurality of slits (23a-23e; 23a-23f; 23b-23f) that extend substantially horizontally between two opposite lateral regions of the bulkhead (10), the slits (23a-23e; 23a-23f; 23b-23f) of the plurality extending at different height.
4. The household cooking oven according to claim 1, wherein the bulkhead (10) has at least in part a box-like structure.
5. The household cooking oven according any one of the preceding claims, wherein the bulkhead (10) is formed by at least two parts (10a, 10b) joined to each other.
6. The household cooking oven according to claims 4 and 5, wherein the bulkhead consists of a rear part (10a) and a front part (10b), the front part (10b) being C-shaped in order to define the cavity (20) together with the rear part (10a).
7. The household cooking oven according to claim 1 or claim 2, wherein the back (10a) of the bulkhead (10) has a projecting lip (21a) towards the impeller (12) of the fan (12, 13) and delimiting the at least one outlet (21).
8. The household cooking oven according to claim 1 or claim 3, wherein the inlet openings (23a-23e; 23a-23f; 23b-23f) each have a mouth defined by a respective lip (24) projecting from the front (10b) of the bulkhead (10) towards the cooking chamber.

9. The household cooking oven according to claim 1 or claim 3, wherein the cooking chamber has, at two opposite lateral walls (5d) of the muffle (5), support means (6) to support removable shelves (7, 8) in a plurality of different height positions (A-E) within the cooking chamber, the inlet openings (23a-23e; 23a-23f; 23b-23f) and the support means (6) being in such positions that, in at least one of said height positions (A-E), a shelf (7, 8) extend at an height that is intermediate to two of said inlet openings (23a-23e; 23a-23f; 23b-23f).
10. The household cooking oven according to claim 1 or claim 3, herein the air-suction cavity (20) has a peripheral profile with two opposite sides having an alternation of crests and valley (20a, 20b), one or more of the inlet openings (23a-23e; 23a-23f; 23b-23f) having opposite end regions that each extend each within the boundary of a crest (20a) of a respective side of the peripheral profile of the air-suction cavity (20).
11. The household cooking oven according to claim 1 or claim 3, wherein the plurality of inlet openings (23a-23e; 23a-23f; 23b-23f) comprises at least one pair of inlet openings (23d, 23e; 23a-23f) that are closer to each other than at least two other inlet openings of the plurality (23a-23e; 23a-23f; 23b-23f), the pair of inlet openings being preferably in an upper region of the front (10b) of the bulkhead (10).
12. The household cooking oven according to claim 1 or claim 3, wherein the plurality of inlet openings (23a-23e; 23a-23f; 23b-23f) comprises at least one inlet opening (23f; 23e) at a peripheral profile of the air-suction cavity (20), in particular at a top side or a bottom side of the air-suction cavity (20).
13. The household cooking oven according to any one of the preceding claims, wherein the outlet section (15, 22) comprises one or more deflector elements (15) to correct direction of air, in particularly according to the inertia of motion induced by the impeller (12), the deflector elements (15) being at the back (10b) of the bulkhead (10).
- erstreckt, teilt, wobei in der Luftverteilungskammer betriebsfähig mindestens ein Heizwiderstand (11) und ein Laufrad (12) eines Zentrifugallüfters (12, 13) angeordnet sind, wobei die Luftverteilungskammer einen Auslassabschnitt (15, 22) zur Zufuhr von Luft zu der Kochkammer und einen Einlassabschnitt (20-23) zur Aufnahme von Luft von der Kochkammer aufweist, wobei der Auslassabschnitt (15, 22) Durchgänge (22) in im Allgemeinen peripheren Positionen der Luftverteilungskammer umfasst, wobei der Einlassabschnitt (20-23) einen Luftansaughohlraum oder eine -kammer (20) umfasst, der/die in dem Schott (10) definiert ist, wobei der Luftansaughohlraum (20) mindestens einen Einlass (23), der in einer Front (10b) des Schotts (10) definiert ist und zu der Kochkammer ausgerichtet ist, und mindestens einen Auslass (21), der in einer Rückseite (10a) des Schotts (10) definiert ist und zu dem Laufrad (12) des Lüfters (12, 13) ausgerichtet ist, aufweist, wobei der Ofen **dadurch gekennzeichnet ist, dass** der mindestens eine Auslass (21) ein im Wesentlichen elliptisches Profil mit im Wesentlichen vertikaler Hauptachse aufweist und wobei der mindestens eine Einlass (23) eine Vielzahl von sich längs erstreckenden Einlassöffnungen umfasst.
2. Haushaltsbackofen nach Anspruch 1, wobei der mindestens eine Auslass eine einzelne Öffnung (21) umfasst, bevorzugt im Wesentlichen koaxial mit einer Drehachse des Laufrads (12) des Lüfters (12, 13).
3. Haushaltsbackofen nach Anspruch 2, wobei die Einlassöffnungen eine Vielzahl von Schlitzen (23a-23e; 23a-23f; 23b-23f) umfassen, die sich im Wesentlichen horizontal zwischen zwei gegenüberliegenden seitlichen Bereichen des Schotts (10) erstrecken, wobei die Schlitze (23a-23e; 23a-23f; 23b-23f) der Vielzahl sich bei unterschiedlichen Höhen erstrecken.
4. Haushaltsbackofen nach Anspruch 1, wobei das Schott (10) mindestens teilweise eine kastenähnliche Struktur aufweist.
5. Haushaltsbackofen nach einem der vorstehenden Ansprüche, wobei das Schott (10) von mindestens zwei Teilen (10a, 10b) gebildet ist, die miteinander verbunden sind.
6. Haushaltsbackofen nach Anspruch 4 oder 5, wobei das Schott aus einem Rückteil (10a) und einem Frontteil (10b) besteht, wobei das Frontteil (10b) C-förmig ist, um den Hohlraum (20) gemeinsam mit dem Rückteil (10a) zu definieren.
7. Haushaltsbackofen nach Anspruch 1 oder Anspruch 2, wobei die Rückseite (10a) des Schotts (10) eine

Patentansprüche

1. Haushaltsbackofen (1), umfassend eine Lagerstruktur (2), eine Muffe (5) und eine Vordertür (4), um die Muffe (5) frontal zu schließen, wobei in der Muffe (5) ein Schott (10) vorliegt, das im Allgemeinen zu einer Muffenrückwand (5a) zeigt, das Schott (10) das Innere der Muffe (5) in eine Frontkochkammer, die sich zwischen der Türe (4) und dem Schott (10) erstreckt, und eine Rückluftverteilungskammer, die sich zwischen dem Schott (10) und der Muffenrückwand (5a)

Fortsatzlippe (21a) zu dem Laufrad (12) des Lüfters (12, 13) aufweist und den mindestens einen Auslass (21) abgrenzt.

8. Haushaltsbackofen nach Anspruch 1 oder Anspruch 3, wobei die Einlassöffnungen (23a-23e; 23a-23f; 23b-23f) jeweils einen Mund aufweisen, der durch eine jeweilige Lippe (24) definiert ist, die von der Front (10b) des Schotts (10) zu der Kochkammer vorsteht.
9. Haushaltsbackofen nach Anspruch 1 oder Anspruch 3, wobei die Kochkammer bei zwei gegenüberliegenden Seitenwänden (5d) der Muffe (5) Stützmittel (6) aufweist, um entfernbare Roste (7, 8) in einer Vielzahl von unterschiedlichen Höhenpositionen (A-E) innerhalb der Kochkammer zu stützen, wobei die Einlassöffnungen (23a-23e; 23a-23f; 23b-23f) und die Stützmittel (6) in solchen Positionen sind, dass in mindestens einer der Höhenpositionen (A-E) ein Rost (7, 8) sich bei einer Höhe erstreckt, die zwischen zwei der Einlassöffnungen (23a-23e; 23a-23f; 23b-23f) ist.
10. Haushaltsbackofen nach Anspruch 1 oder Anspruch 3, wobei der Luftansaughohlraum (20) ein Umfangsprofil mit zwei gegenüberliegenden Seiten aufweist, die eine Abwechslung von Erhebungen und Vertiefungen (20a, 20b) aufweisen, wobei eine oder mehrere der Einlassöffnungen (23a-23e; 23a-23f; 23b-23f) gegenüberliegende Endbereiche aufweisen, die sich jeweils innerhalb der Grenzen einer Erhöhung (20a) einer jeweiligen Seite des Umfangsprofils des Luftansaughohlraums (20) erstrecken.
11. Haushaltsbackofen nach Anspruch 1 oder Anspruch 3, wobei die Vielzahl von Einlassöffnungen (23a-23e; 23a-23f; 23b-23f) mindestens ein Paar von Einlassöffnungen (23d, 23e; 23a-23f) umfasst, die näher zueinander sind als mindestens zwei andere Einlassöffnungen der Vielzahl (23a-23e; 23a-23f; 23b-23f), wobei das Paar von Einlassöffnungen bevorzugt in einem oberen Bereich der Front (10b) des Schotts (10) ist.
12. Haushaltsbackofen nach Anspruch 1 oder Anspruch 3, wobei die Vielzahl von Einlassöffnungen (23a-23e; 23a-23f; 23b-23f) mindestens eine Einlassöffnung (23f; 23e) bei einem Umfangsprofil des Luftansaughohlraums (20) umfasst, insbesondere bei einer Oberseite oder einer Unterseite des Luftansaughohlraums (20).
13. Haushaltsbackofen nach einem der vorstehenden Ansprüche, wobei der Auslassabschnitt (15, 22) ein oder mehrere Deflektorelemente (15) umfasst, um Luftrichtung zu korrigieren, insbesondere gemäß der Bewegungsträgheit, die durch das Laufrad (12) ver-

ursacht ist, wobei die Deflektorelemente (15) an der Rückseite (10b) des Schotts (10) sind.

5 Revendications

1. Four de cuisson ménager (1), comprenant une structure porteuse (2), un moufle (5) et une porte avant (4) pour fermer frontalement le moufle (5), étant présente dans le moufle (5) une cloison (10) généralement face à une paroi de moufle arrière (5a), la cloison (10) divisant l'intérieur du moufle (5) en une chambre de cuisson avant, qui s'étend entre la porte (4) et la cloison (10), et une chambre de distribution d'air arrière, qui s'étend entre la cloison (10) et la paroi de moufle arrière (5a), dans lequel dans la chambre de distribution d'air se trouvent agencées fonctionnellement au moins une résistance chauffante (11) et une hélice (12) d'un ventilateur centrifuge (12, 13), dans lequel la chambre de distribution d'air possède une section de sortie (15, 22) pour l'apport d'air à la chambre de cuisson et une section d'entrée (20 à 23) pour l'admission d'air depuis la chambre de cuisson, la section de sortie (15, 22) comprenant des voies de passage (22) dans des positions généralement périphériques de la chambre de distribution d'air, dans lequel la section d'entrée (20 à 23) comprend une cavité ou chambre d'aspiration d'air (20) définie dans la cloison (10), la cavité d'aspiration d'air (20) ayant au moins une entrée (23), définie dans un avant (10b) de la cloison (10) et orientée vers la chambre de cuisson, et au moins une sortie (21), définie dans un arrière (10a) de la cloison (10) et orientée vers l'hélice (12) du ventilateur (12, 13), le four étant **caractérisé en ce qu'**au moins une sortie (21) présente un profil sensiblement elliptique avec un axe majeur sensiblement vertical, et dans lequel l'au moins une entrée (23) comprend une pluralité d'ouvertures d'entrée en extension longitudinale.
2. Four de cuisson ménager selon la revendication 1, dans lequel l'au moins une sortie comprend une ouverture unique (21), de préférence sensiblement coaxiale à un axe de rotation de l'hélice (12) du ventilateur (12, 13).
3. Four de cuisson ménager selon la revendication 2, dans lequel les ouvertures d'entrée comprennent une pluralité de fentes (23a à 23e ; 23a à 23f; 23b à 23f) qui s'étendent sensiblement horizontalement entre deux régions latérales opposées de la cloison (10), les fentes (23a à 23e ; 23a à 23f ; 23b à 23f) de la pluralité s'étendant à une hauteur différente.
4. Four de cuisson ménager selon la revendication 1, dans lequel la cloison (10) présente au moins en partie une structure de type boîte.

5. Four de cuisson ménager selon l'une quelconque des revendications précédentes, dans lequel la cloison (10) est formée par au moins deux parties (10a, 10b) jointes l'une à l'autre.
6. Four de cuisson ménager selon les revendications 4 et 5, dans lequel la cloison consiste en une partie arrière (10a) et une partie avant (10b), la partie avant (10b) étant en forme de C afin de définir la cavité (20) conjointement à la partie arrière (10a).
7. Four de cuisson ménager selon la revendication 1 ou la revendication 2, dans lequel l'arrière (10a) de la cloison (10) possède une lèvre en saillie (21a) vers l'hélice (12) du ventilateur (12, 13) et délimitant l'au moins une sortie (21).
8. Four de cuisson ménager selon la revendication 1 ou la revendication 3, dans lequel les ouvertures d'entrée (23a à 23e; 23a à 23f; 23b à 23f) possèdent chacune une embouchure définie par une lèvre respective (24) en saillie depuis l'avant (10b) de la cloison (10) vers la chambre de cuisson.
9. Four de cuisson ménager selon la revendication 1 ou la revendication 3, dans lequel la chambre de cuisson possède, au niveau de deux parois latérales opposées (5d) du moufle (5), des moyens de support (6) pour supporter des tablettes amovibles (7, 8) dans une pluralité de positions de hauteur différentes (A à E) au sein de la chambre de cuisson, les ouvertures d'entrée (23a à 23e ; 23a à 23f; 23b à 23f) et les moyens de support (6) étant dans des positions telles que, dans au moins l'une desdites positions de hauteur (A à E), une tablette (7, 8) s'étend à une hauteur qui est intermédiaire de deux desdites ouvertures d'entrée (23a à 23e ; 23a à 23f ; 23b à 23f).
10. Four de cuisson ménager selon la revendication 1 ou la revendication 3, dans lequel la cavité d'aspiration d'air (20) présente un profil périphérique avec deux côtés opposés ayant une alternance de crêtes et de creux (20a, 20b), une ou plusieurs des ouvertures d'entrée (23a à 23e ; 23a à 23f; 23b à 23f) ayant des régions d'extrémité opposée qui s'étendent chacune au sein de la frontière d'une crête (20a) d'un côté respectif du profil périphérique de la cavité d'aspiration d'air (20).
11. Four de cuisson ménager selon la revendication 1 ou la revendication 3, dans lequel la pluralité d'ouvertures d'entrée (23a à 23e ; 23a à 23f; 23b à 23f) comprend au moins une paire d'ouvertures d'entrée (23d, 23e; 23a à 23f) qui sont plus proches l'une de l'autre qu'au moins deux autres ouvertures d'entrée de la pluralité (23a à 23e ; 23a à 23f ; 23b à 23f), la paire d'ouvertures d'entrée étant de préférence dans une région supérieure de l'avant (10b) de la cloison (10).
12. Four de cuisson ménager selon la revendication 1 ou la revendication 3, dans lequel la pluralité d'ouvertures d'entrée (23a à 23e ; 23a à 23f; 23b à 23f) comprend au moins une ouverture d'entrée (23f; 23e) au niveau d'un profil périphérique de la cavité d'aspiration d'air (20), en particulier au niveau d'un côté haut ou d'un côté bas de la cavité d'aspiration d'air (20).
13. Four de cuisson ménager selon l'une quelconque des revendications précédentes, dans lequel la section de sortie (15, 22) comprend un ou plusieurs éléments déflecteurs (15) pour corriger une direction d'air, en particulier selon l'inertie de mouvement induite par l'hélice (12), les éléments déflecteurs (15) étant au niveau de l'arrière (10b) de la cloison (10).

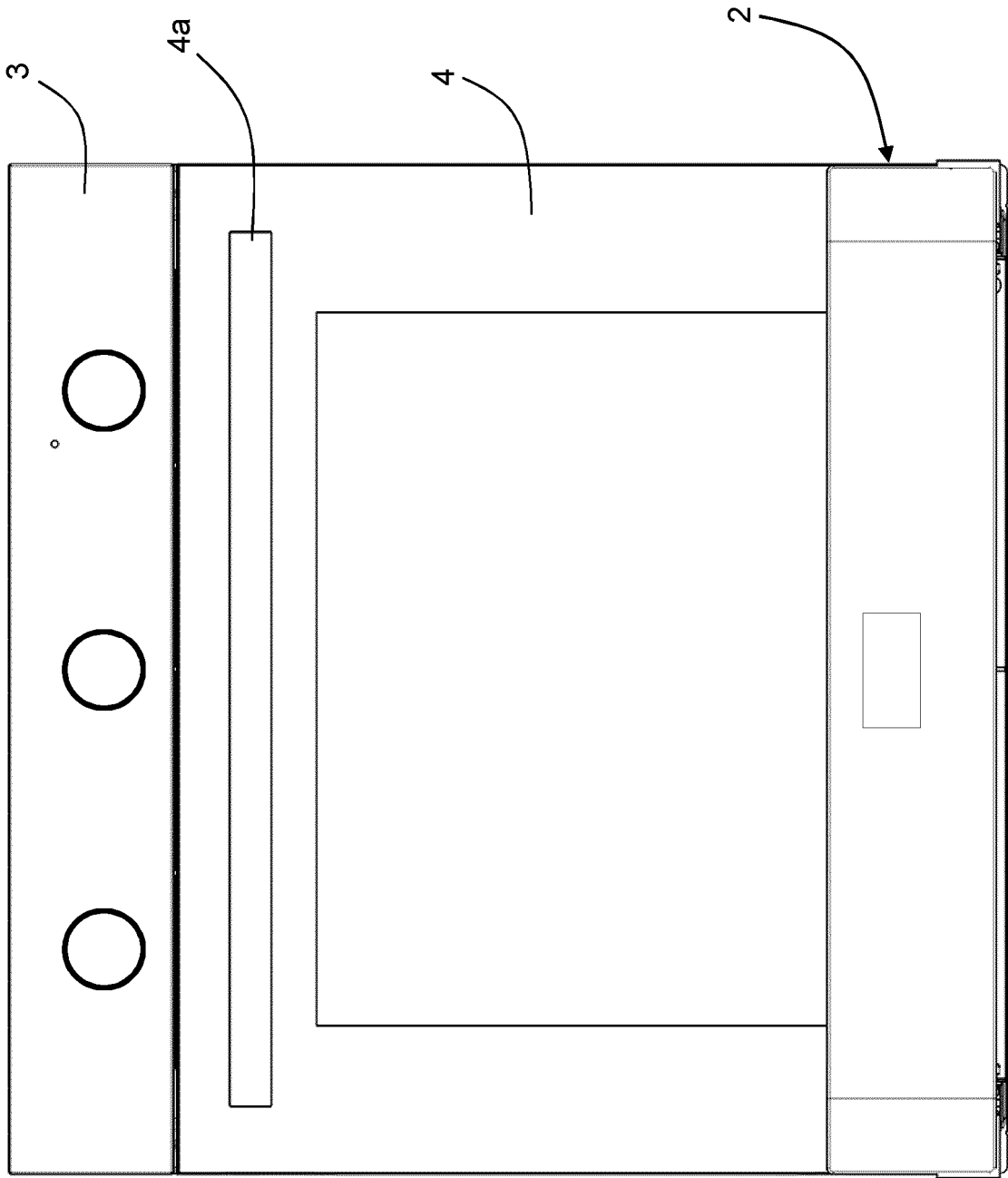
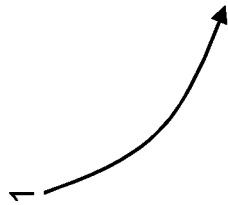
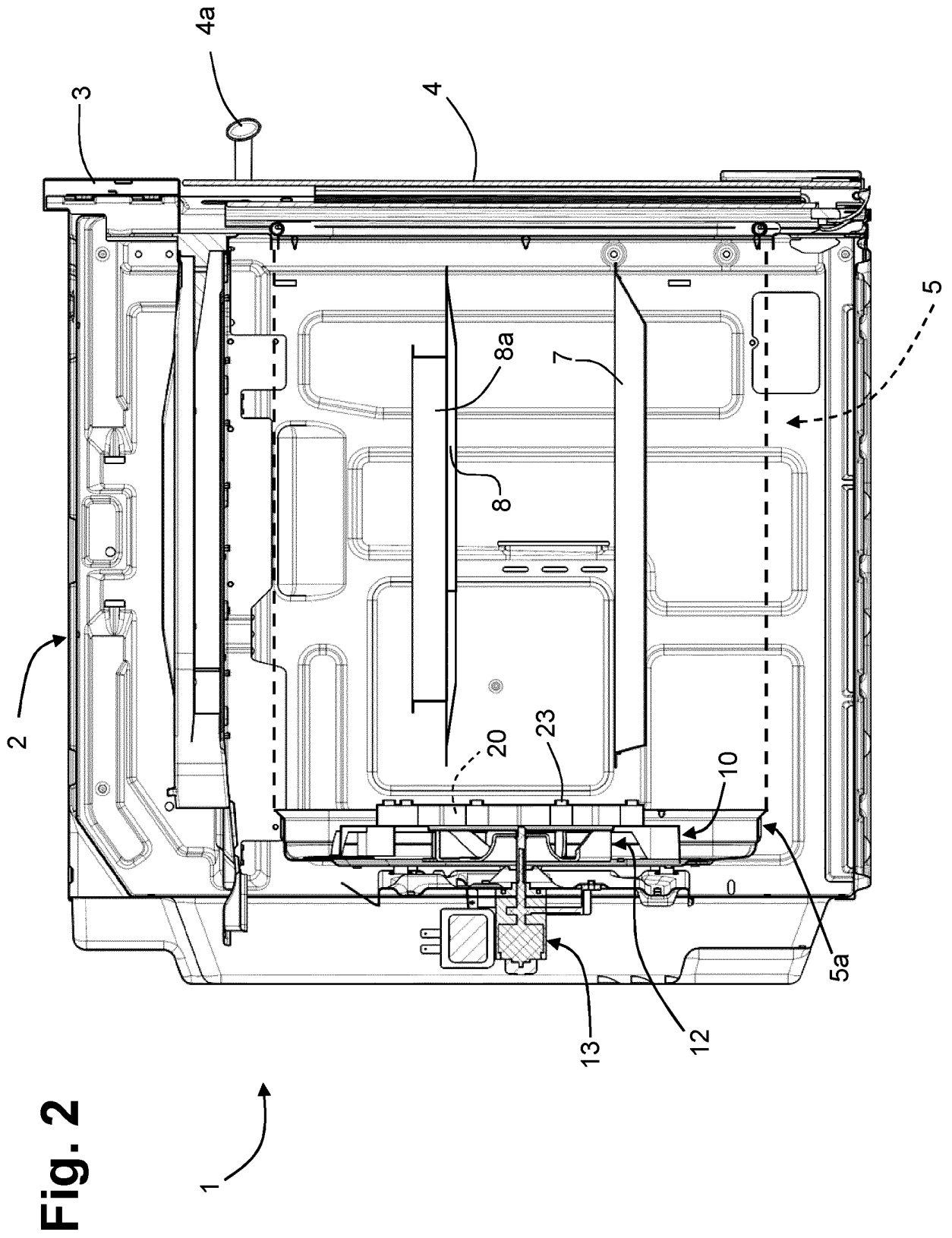

Fig. 1





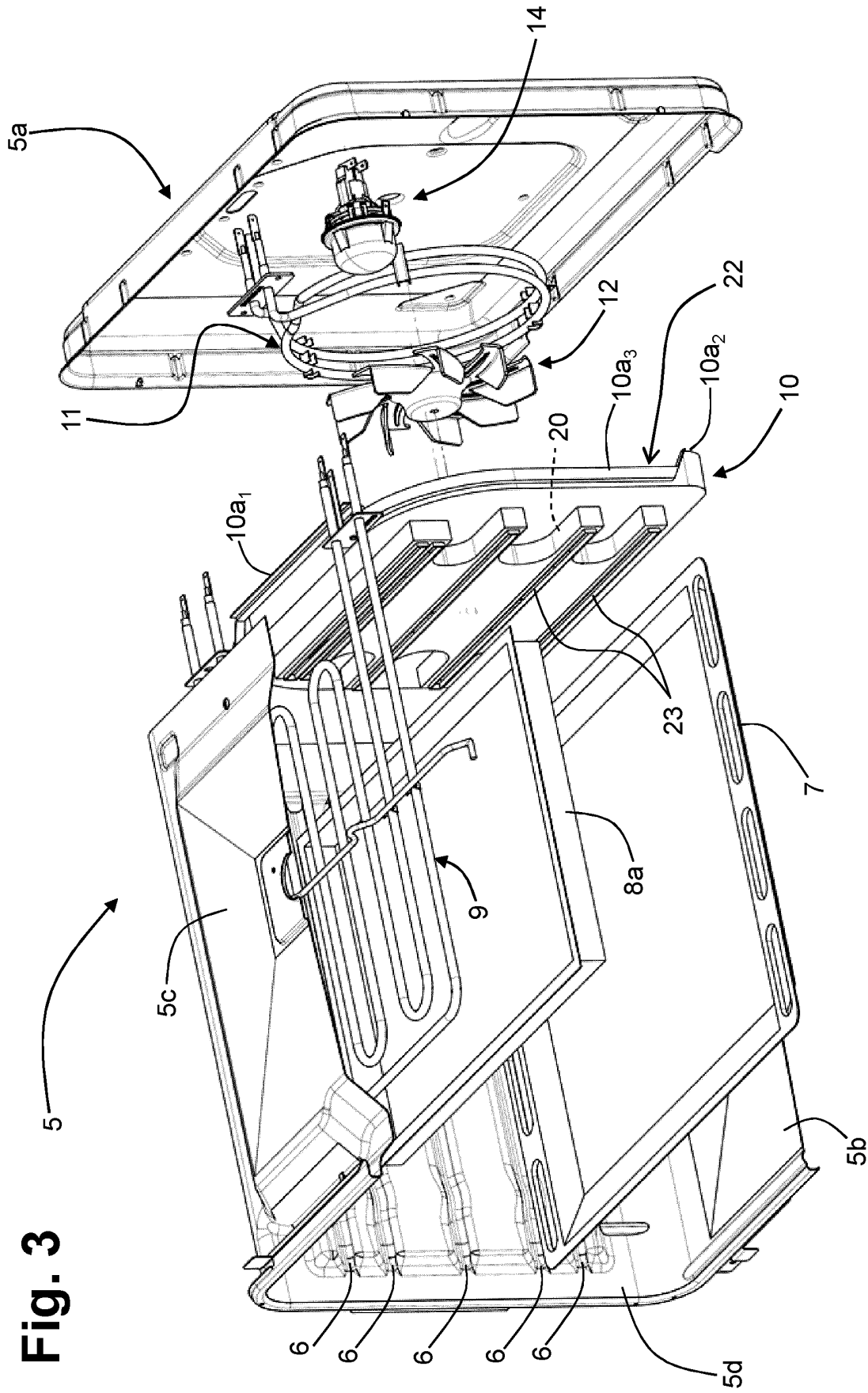

Fig. 3

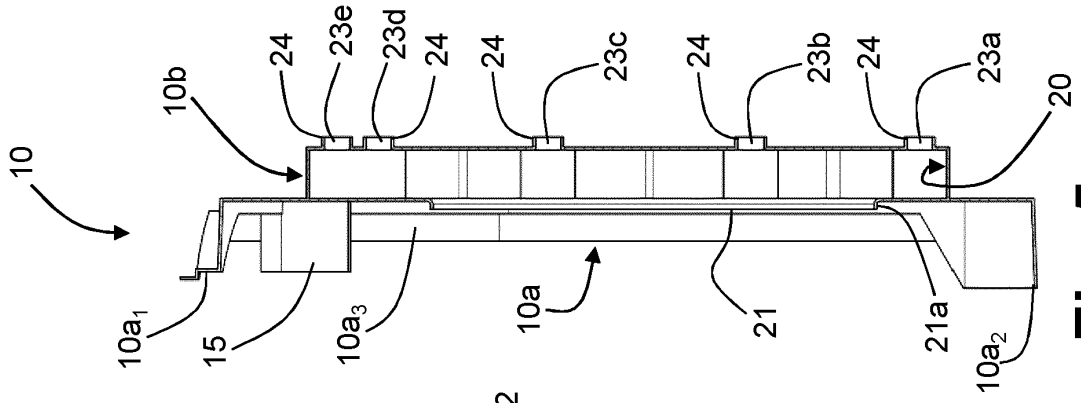

Fig. 5

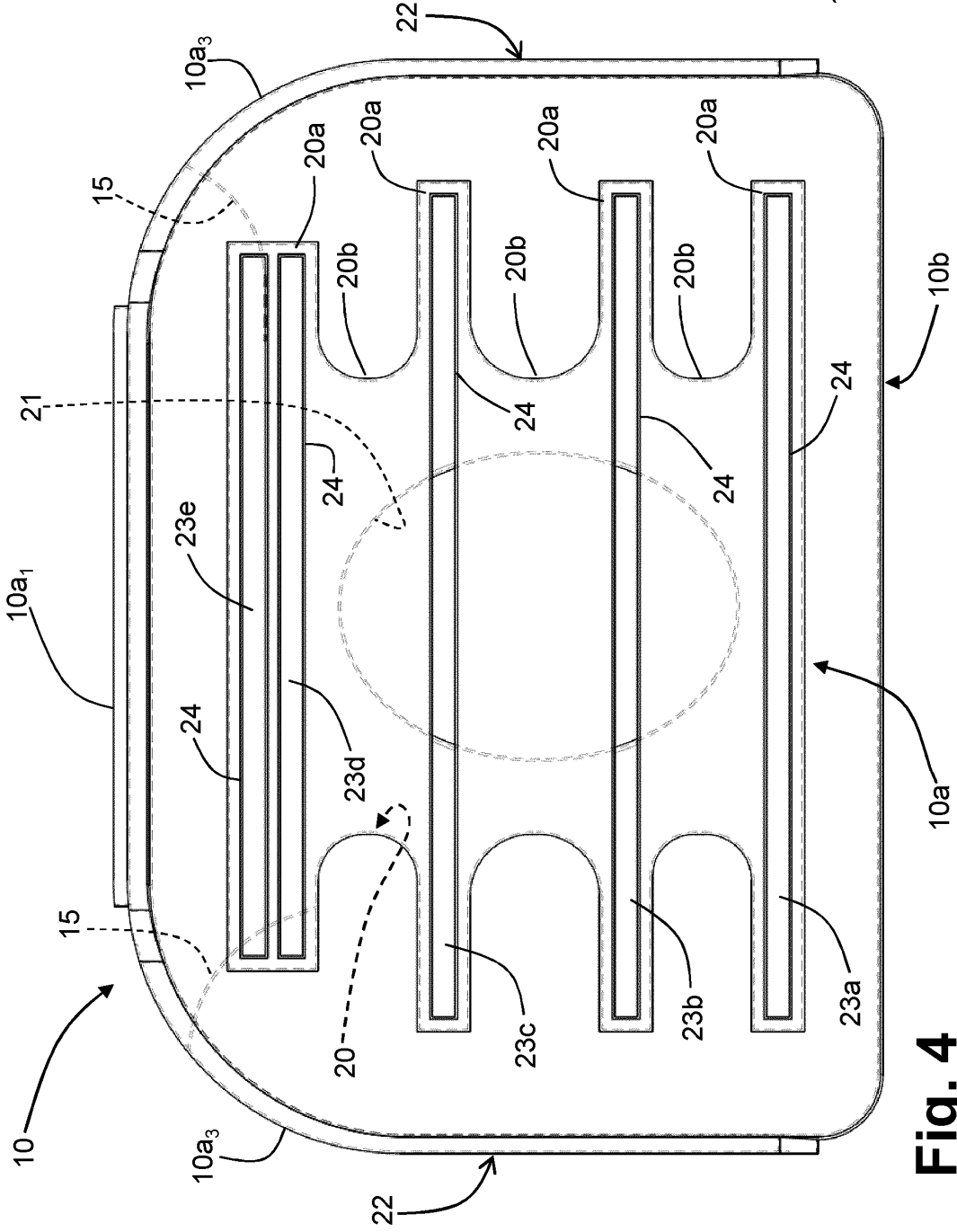
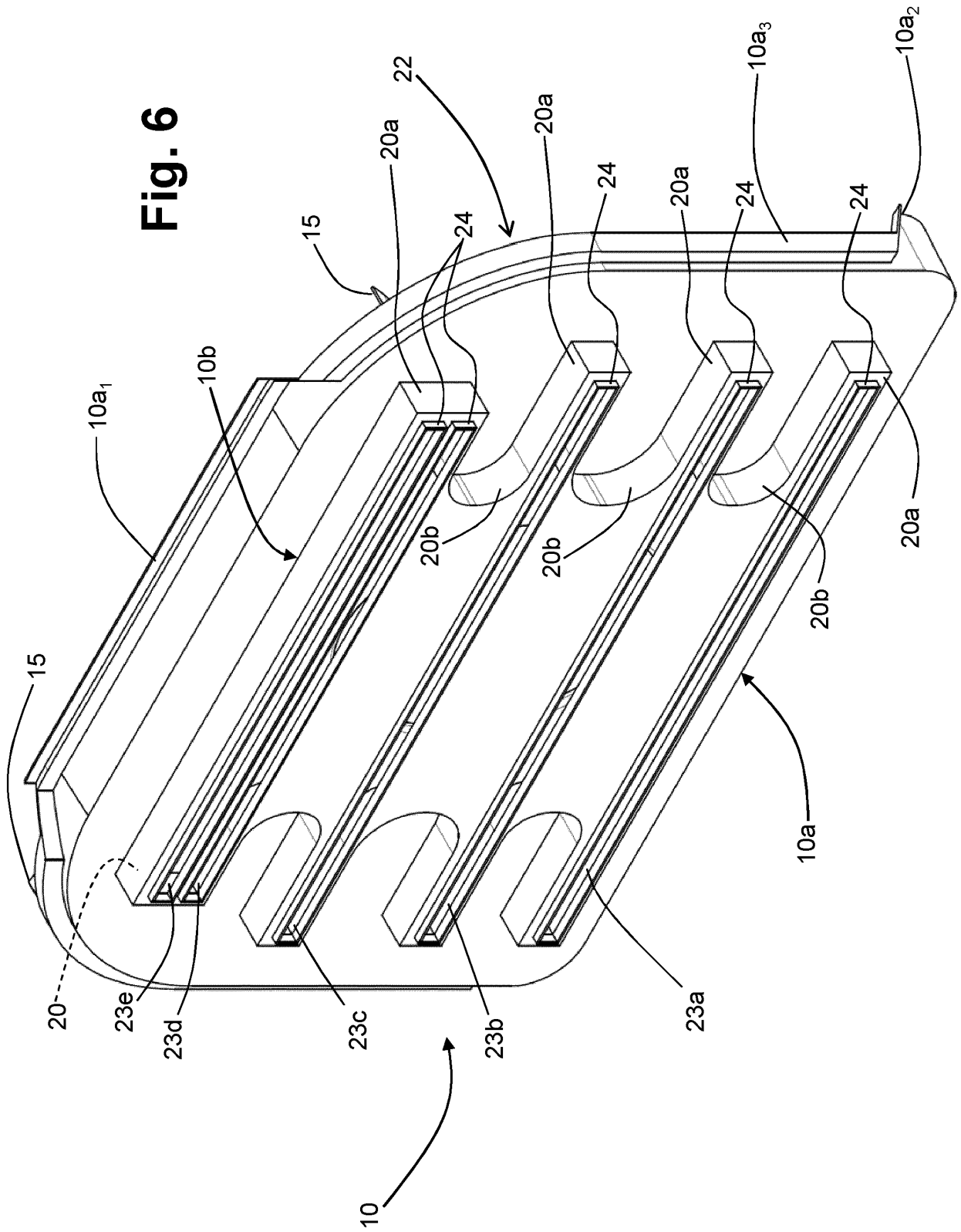

Fig. 4

Fig. 6



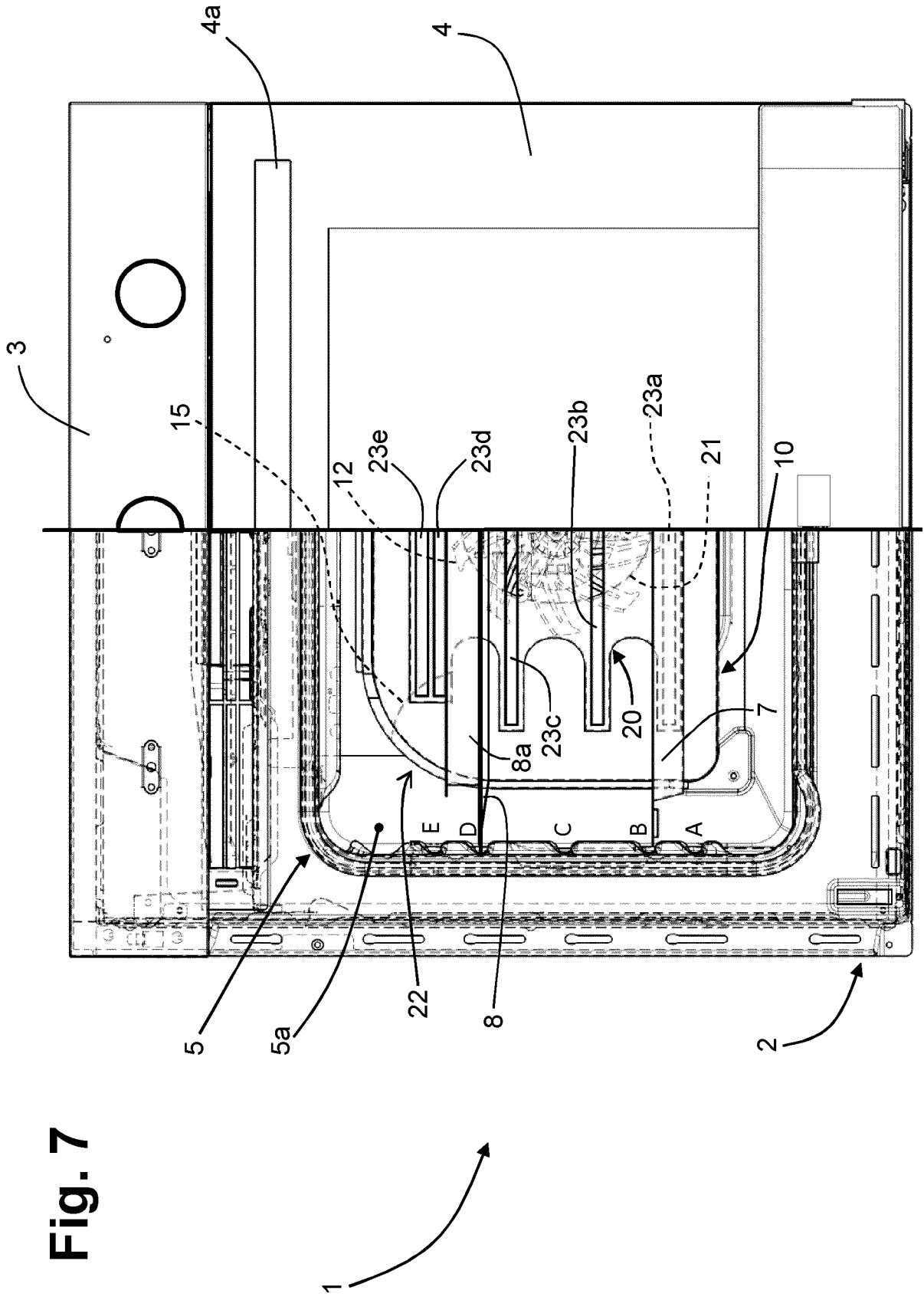

Fig. 7

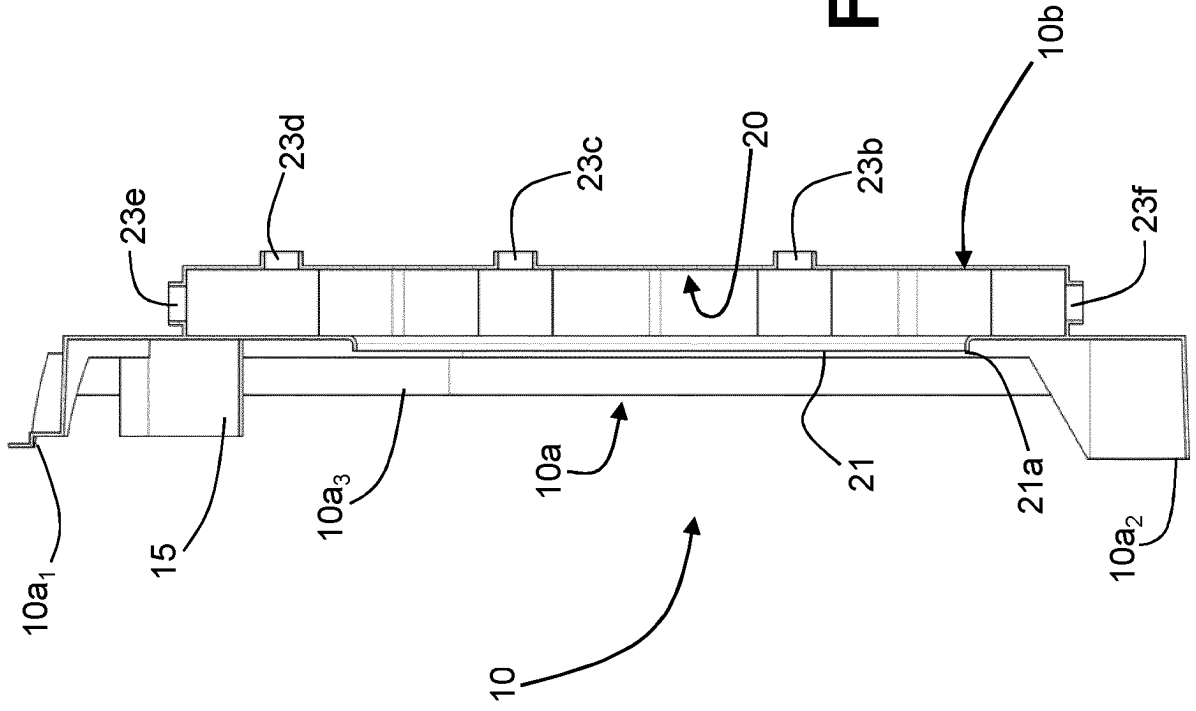

Fig. 9

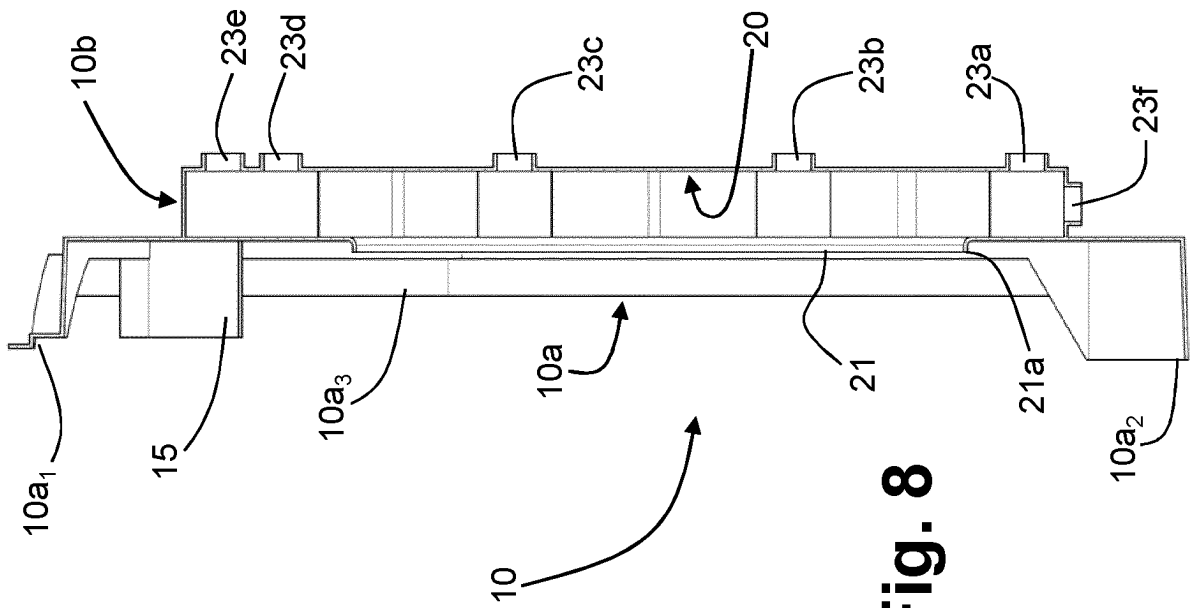

Fig. 8

REFERENCES CITED IN THE DESCRIPTION

This list of references cited by the applicant is for the reader's convenience only. It does not form part of the European patent document. Even though great care has been taken in compiling the references, errors or omissions cannot be excluded and the EPO disclaims all liability in this regard.

Patent documents cited in the description

- DE 102008042473 A1 **[0005]**
- EP 2735806 A1 **[0006]**