

(19) AUSTRALIAN PATENT OFFICE

(54) Title
NMR apparatus

(51)⁶ International Patent Classification(s)
G01R 33/38 (2006.01) 33/44
G01R 33/44 (2006.01) 20060101ALI2005100
G01R 33/48 (2006.01) ⁸BMEP **G01R**
G01R 33/38 33/48
20060101AFI2005100 20060101ALN200510
⁸BMEP **G01R** 08BMEP
PCT/NZ2003/000149

(21) Application No: 2003281119 (22) Application Date: 2003 .07 .11

(87) WIPO No: W004/008168

(30) Priority Data

(31) Number	(32) Date	(33) Country
520114	2002 .07 .11	NZ

(43) Publication Date : 2004 .02 .02
(43) Publication Journal Date : 2004 .03 .18

(71) Applicant(s)
Massey University, Victoria Link Limited

(72) Inventor(s)
Dykstra, ROBIN, Callaghan, PAUL TERENCE, Eccles, CRAIG DAVID, Hunter, MARK
WARWICK

(74) Agent/Attorney
A J PARK, Level 11 60 Marcus Clarke Street, Canberra, ACT, 2601

(56) Related Art
US 4931760A; US 6278351B1; US 5900793A; US 5646528A; US 6404197B1; EP 171831B1

(12) INTERNATIONAL APPLICATION PUBLISHED UNDER THE PATENT COOPERATION TREATY (PCT)

(19) World Intellectual Property
Organization
International Bureau



(43) International Publication Date
22 January 2004 (22.01.2004)

PCT

(10) International Publication Number
WO 2004/008168 A1

- (51) International Patent Classification⁷: G01R 33/20, 33/34
- (21) International Application Number: PCT/NZ2003/000149
- (22) International Filing Date: 11 July 2003 (11.07.2003)
- (25) Filing Language: English
- (26) Publication Language: English
- (30) Priority Data: 520114 11 July 2002 (11.07.2002) NZ
- (71) Applicants (for all designated States except US): VICTORIA LINK LIMITED [NZ/NZ]; 15 Mount Street, Kelburn, Wellington (NZ). MASSEY UNIVERSITY [NZ/NZ]; Palmerston North (NZ).
- (72) Inventors; and
- (75) Inventors/Applicants (for US only): CALLAGHAN, PAUL, TERENCE [NZ/NZ]; 313A The Terrace, Wellington (NZ). HUNTER, MARK, WARWICK [NZ/NZ]; 407 Albert Street, Palmerston North (NZ). DYKSTRA, ROBIN [NZ/NZ]; 374 Scotts Road, RD 4, Palmerston North (NZ). ECCLES, CRAIG, DAVID [NZ/NZ]; 20 Worcester Street, Wilton, Wellington (NZ).
- (74) Agents: WEST-WALKER, Gregory, J. et al.; A J Park, 6th Floor Huddart Parker Building, Post Office Square, PO Box 949, 6015 Wellington (NZ).
- (81) Designated States (national): AE, AG, AI, AM, AT, AU, AZ, BA, BB, BG, BR, BY, BZ, CA, CH, CN, CO, CR, CU, CZ, DE, DK, DM, DZ, EC, EE, ES, FI, GB, GD, GE, GH, GM, HR, HU, ID, IL, IN, IS, JP, KE, KG, KP, KR, KZ, LC, LK, LR, LS, LT, LU, LV, MA, MD, MG, MK, MN, MW, MX, MZ, NI, NO, NZ, OM, PG, PH, PL, PT, RO, RU, SC, SD, SE, SG, SK, SI, SY, TJ, TM, TN, TR, TT, TZ, UA, UG, US, UZ, VC, VN, YU, ZA, ZM, ZW.
- (84) Designated States (regional): ARIPO patent (GH, GM, KE, LS, MW, MZ, SD, SL, SZ, TZ, UG, ZM, ZW), Eurasian patent (AM, AZ, BY, KG, KZ, MD, RU, TJ, TM), European patent (AT, BE, BG, CH, CY, CZ, DE, DK, EE, ES, FI, FR, GB, GR, HU, IE, IT, LU, MC, NL, PT, RO, SE, SI, SK, TR), OAPI patent (BF, BJ, CF, CG, CI, CM, GA, GN, GQ, GW, ML, MR, NE, SN, TD, TG).

[Continued on next page]

(54) Title: NMR APPARATUS

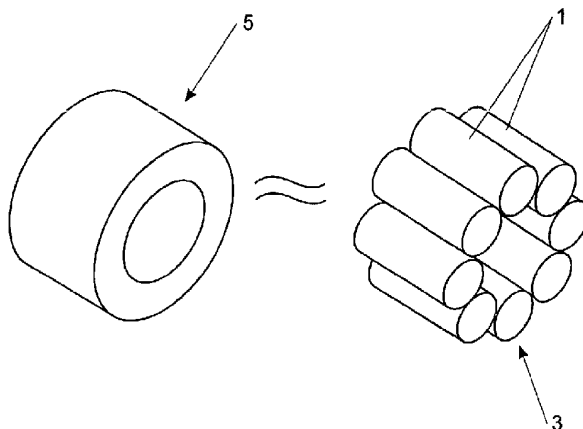

(57) Abstract: A magnetic assembly for a nuclear magnetic resonance apparatus includes a number of primary permanent magnets 1 disposed in an array about a longitudinal axis, the arrangement and/or characteristics of the plurality of magnets being such so as to create a zone of homogeneous magnetic field at some location along the axis forward of the array (and into the material when provided). A secondary permanent magnet 7 may be located along the longitudinal axis within the array of primary magnets and may be moveable. The primary magnets 1 have a north pole and a south pole with an axis therebetween, and may be arranged such that the axis between the poles is at an angle to the longitudinal axis.

WO 2004/008168 A1



Published:

— with international search report

For two-letter codes and other abbreviations, refer to the "Guidance Notes on Codes and Abbreviations" appearing at the beginning of each regular issue of the PCT Gazette.

NMR APPARATUS**FIELD OF THE INVENTION**

The present invention relates to a magnetic assembly for a nuclear magnetic resonance spectroscopy apparatus. More particularly but not exclusively it relates to one-sided access nuclear magnetic resonance spectroscopy apparatus.

BACKGROUND TO THE INVENTION

This invention relates to the field of nuclear magnetic resonance (NMR) spectroscopic devices. NMR spectroscopy is an analytical and diagnostic technique that can be used for the structural and quantitative analysis of a compound in a mixture. NMR is based on the nuclear magnetic properties of certain elements and isotopes of those elements. It is based on the principle that nuclei with a non-zero spin will have a magnetic dipole and therefore will interact with electromagnetic (EM) radiation.

The presence or absence of a spin and the nature of this spin is expressed in terms of the spin quantum number of the nucleus, which may either be 0, $\frac{1}{2}$ or multiples of $\frac{1}{2}$.

In a uniform magnetic field a nucleus having a spin quantum number of $\frac{1}{2}$ may assume two orientations relative to the applied magnetic field. The two orientations have different energies so that it is possible to induce a nuclear transition by the application of electromagnetic radiation of the appropriate frequency. This transition is resonance. Resonance arises when the correct combination of magnetic field strength and exciting frequency characteristics of the nuclei of interest are applied.

After resonance is achieved the NMR instrument records a signal, the signal being a function of the nature and amount of a compound of the test sample as well as nuclear magnetic relaxation considerations.

An NMR spectrometer generally comprises one or more magnets producing a strong homogenous field within a test region. The size and complexity of NMR spectrometers are largely a function of the magnetic field requirements.

Conventional NMR requires a laboratory electromagnet, or superconducting magnet. The spectroscopic information is obtained by using uniform magnetic fields and thus the technique is inherently invasive as the field uniformity is restricted to small volumes and materials must be placed inside the magnet system.

An alternative design is the "inside out" NMR which uses open magnet designs for measurements in the field without sample size restrictions. However a disadvantage of such a design is reduced sensitivity and lack of resolution and the field is less uniform than in such a magnetic configuration.

A development beyond the use of inside out NMR relates to the development of mobile NMR devices which have been developed for analysis of many things including oil wells, water reservoirs, plant growth and life cycles and moisture detection (for example in wood or concrete).

There are a number of difficulties associated with the development of small scale inside NMR apparatus. These include:

- 1) the homogeneity of the magnetic field;
- 2) it is important to provide a magnet with the highest field possible;
- 3) such a strong magnetic field generally requires larger, heavier magnets, which increases the costs of the spectrometer;
- 4) with such a magnet configuration typically only the surface area of a subject can be analysed by the technique.

A number of parties have applied themselves to these difficulties in the development of small scale NMR apparatus.

US 6,163,154, (Anderson et al), discusses the development of small scale NMR apparatus for the measurement of a patient's glucose levels. It employs a pair of opposed permanent magnets and a plurality of annual circular magnets which are cancelling magnets.

US 6,081,116, (Wu et al), deals with NMR apparatus for geological applications and employs a plurality of cylindrical magnets to approximate a permanent ring magnet. This will reduce the cost of the use of a single ring magnet.

US 5,959,454, (Westphal et al), deals with the magnet arrangement for an NMR tomography system for skin and surface examinations. This is a one sided NMR system having two ring magnets and a cylindrical magnet the locations being so as to impart a certain degree of uniformity.

A number of people have alternatively attempted to deal with the problem that in one sided NMR, often only the surface region of the sample is analysable due to magnetic field concerns.

US 5,739,688, (Krieg), attempts to profile in the z-axis direction (into the sample), by employing a static magnetic field having a predetermined inhomogeneity in the z direction. It uses slices perpendicular to the direction of inhomogeneity (z axis) with operating the apparatus by a pulse sequence with shortened measurement time. This allows for excitation of one slice independent of another, and overcomes relaxation disadvantages.

US 5,126,674, (Miller et al), again deals with a one sided NMR apparatus and the technique of planar imaging. It creates an inhomogeneous magnetic field and the RF frequency selection excites only one "volume of interest" at a time. Again there is no need for relaxation as each is excited independently of the other.

US 4,528,509, (Radda et al), and US 4,710,713, (Strikman), both similarly deal with three dimension imaging via a homogenous field in the z-axis direction.

OBJECT OF THE INVENTION

It is an object of the present invention to provide a magnetic assembly for an NMR apparatus, or an NMR apparatus, which overcomes or at least ameliorates some of the abovementioned disadvantages; or which at least provides the public with a useful choice.

Other objects of the invention may become apparent from the following description which is given by way of example only.

SUMMARY OF THE INVENTION

The term "comprising" as used in this specification means "consisting at least in part of". When interpreting each statement in this specification that includes the term "comprising", features other than that or those prefaced by the term may also be present. Related terms such as "comprise" and "comprises" are to be interpreted in the same manner.

In accordance with a first aspect of the present invention, there is provided a magnetic assembly for an NMR apparatus, comprising a plurality of primary permanent magnets disposed in an annular array about an axis (hereafter "longitudinal axis"), wherein each of the magnets has a north pole and a south pole with an axis extending therebetween, and each of the primary magnets is arranged such that its axis is oriented at a non-parallel angle to the longitudinal axis of the assembly, the assembly further comprising a secondary permanent magnet located on the longitudinal axis, at a position at least partly within the array of primary magnets, with the non-parallel angles of the primary magnet axes and the position of the secondary magnet selected to create a zone of homogeneous magnetic field at a location along the axis forward of the array, and into a material when provided.

Advantageously, the position of the secondary permanent magnet is adjustable along the longitudinal axis relative to the primary magnets.

The secondary magnet may be a cylindrical bar magnet.

Preferably, the secondary magnet is positioned such that the first and second spatial derivatives of the magnetic field are zero at some coincident location along the longitudinal axis forward of the array, and into the material when provided.

Preferably, each of the plurality of primary magnets may be a cylindrical bar magnet, each having a proximal end at a front of the array, and a distal end at a rear of the array.

In a preferred embodiment, each of the plurality of primary magnets is tilted at an angle relative to the longitudinal axis, such that the configuration of magnets is in a substantially symmetrical tapered arrangement. The tapered arrangement is preferably according to the expression:

$$R = r|\cos \beta| \sqrt{1 + \frac{1}{\tan^2 \frac{\pi}{N} \cos^2 \beta}} + |l \sin \beta|$$

$$t = \sqrt{r^2 + \left(\frac{l}{2}\right)^2} \max(|\cos(\beta - \phi)|, |\cos(\beta + \phi)|)$$

where

$$\phi = \tan^{-1}\left(\frac{2r}{l}\right)$$

N is the number of magnets used,

r is the radius of the magnets,

l is the length of the magnets,

β is the 'cone angle',

R is the 'ring radius',

and t is the distance along the longitudinal axis from the front of the array to the geometric centre of the magnets.

The proximal end of each of the plurality of primary magnets may be tilted through an angle beta towards the longitudinal axis, such that the configuration of primary magnets is in a substantially symmetrical tapered arrangement, tapering towards the front of the array. Alternatively, the proximal end of each of the plurality of primary magnets may be tilted through an angle beta away from the longitudinal axis, such that the configuration of

primary magnets is in a substantially symmetrical tapered arrangement, tapering away from the front of the array.

The plurality of primary magnets is suitably disposed substantially symmetrically about the longitudinal axis.

The primary magnets may be as close together as is physically or reasonably possible.

Each of the plurality of primary magnets is preferably substantially identical. Preferably, the secondary magnet is of substantially identical dimensions to each of the plurality of primary magnets. Each of the plurality of primary magnets and the secondary magnet may be a cylindrical bar magnet having a radius of about 1.8cm and a length of about 5cm.

The assembly preferably has eight primary magnets.

The nature of the magnets and their relationship to the axis and any intended sample and/or the remainder of the apparatus is preferably as substantially as herein described.

In accordance with a second aspect of the present invention, there is provided a nuclear magnetic resonance apparatus for one sided access investigations of a material, comprising a magnetic assembly according to the first aspect above.

The nuclear magnetic resonance apparatus is preferably portable.

The apparatus is advantageously operable to provide investigations into a sample at up to about 10cm.

The apparatus is preferably operable in such a fashion as to allow excitation of one volume V_a of the material, being one of a plurality of volumes V_1 to V_n existing as slices along the longitudinal axis. Preferably, the apparatus is operable to, following excitation of V_a then allow excitation of a second volume V_b being one of the plurality of volumes V_1 to V_n substantially immediately after excitation of V_a without moving the apparatus, by varying an excitation frequency of the apparatus.

In accordance with a third aspect of the present invention, there is provided a nuclear magnetic resonance apparatus for one sided access investigations of a material, including a plurality of primary permanent magnets disposed in an annular array about an axis (hereafter "longitudinal axis"), and a secondary permanent magnet located on the longitudinal axis, at least partly within the array of primary magnets, the position of the secondary permanent magnet being adjustable along the longitudinal axis relative to the primary magnets, to create a zone of homogeneous magnetic field at a location along the axis forward of the array, and into a material when provided.

In accordance with a fourth aspect of the present invention, there is provided a method of studying the magnetic resonance of a material including the steps of:

- a) employing the NMR apparatus according to the second or third aspect above;
- b) generating a sufficiently homogeneous magnetic field over a volume V_a located at a location along the longitudinal axis in the material thereby causing excitation of subject nuclei in the volume V_a ; and
- c) detecting radio frequency emissions from the subject nuclei in the volume V_a .

The method preferably comprises or includes, subsequent to step c):

- d) substantially immediately following excitation of volume V_a , causing excitation of subject nuclei in a volume V_b , wherein V_b is a volume differing from V_a only in its position along the longitudinal axis, wherein said excitation of volume V_b occurs without moving the apparatus from the position in which volume V_a is excited, by varying an excitation frequency of the apparatus; and
- e) detecting radio frequency emissions from the subject nuclei in the volume V_b .

Where, in this specification the term "homogeneous magnetic field" is used, it is to be given the meaning a sufficiently homogeneous magnetic field so as to enable NMR excitation of a sufficient volume of sample and to provide an analysable NMR signal in that region.

Other aspects of the invention may become apparent from the following description which is given by way of example only and with reference to the accompanying drawings.

Where in the foregoing description reference has been made to elements or integers having known equivalents, then such equivalents are included as if they were individually set forth.

Although the invention has been described by way of example and with reference to particular embodiments, it is to be understood that modifications and/or improvements may be made without departing from the scope or spirit of the invention.

BRIEF DESCRIPTION OF THE DRAWINGS

The invention will now be described by way of example only and with reference to the drawings in which:

- Figure 1: Illustrates the approximation of a cylindrical ring magnet by an array of cylindrical bar magnets.
- Figure 2: illustrates the array of Figure 1 with a central magnet to provide greater field homogeneity.
- Figure 3: illustrates the field produced by the array of Figure 2.
- Figure 4a: illustrates tilting of the outside magnets (cross sectional view).
- Figure 4b: illustrates the field produced by the array of Figure 4a.
- Figure 5a: illustrates the use of a central magnet in the array of Figure 4a (cross sectional view).
- Figure 5b: illustrates the arrangement of Figure 5a.
- Figure 6: illustrates the field produced by the arrays of Figure 5a and 5b.
- Figure 7: illustrates preferred array of the example that will give a homogenous region at a depth of 5.25cm with a field strength of 0.0127T.
- Figure 8: illustrates magnetic field at distance Z for the array of Figure 7.
- Figure 9: illustrates strength of uniform region.
- Figure 10: illustrates position of uniform region.
- Figure 11: illustrates a modified form of the invention in which the faces of the magnets are truncated to sit flush with the surface of the material to be analysed.

DETAILED DESCRIPTION OF PREFERRED FORMS

We have a number of objectives in the development of our system. Firstly we wish to reduce the cost of employing an expensive permanent magnet in portable NMR apparatus applications and secondly we wish to use our magnetic arrangement to study a substrate in the region below the surface. In the preferred embodiments, we achieve this by a unique arrangement of cylindrical magnets. As will be discussed in detail below, this arrangement involves the use of a plurality of cylindrical magnets, arranged to approximate a single ring magnet. Preferably, the magnets are tilted to provide to a cone shaped configuration.

Magnet Array

The starting point for our magnetic arrangement or array involves a replacement of a single ring magnet with a series of cylindrical magnets. These provide an approximation to the ring magnet and have the important advantage that standard "off the shelf" cylindrical magnet can be used. This is a far cheaper way of approaching the problem.

Figure 1 is a schematic illustrating the use of plurality of cylindrical primary permanent magnets 1 in a magnetic assembly 3 to approximate a single permanent ring magnet 5.

To provide a good approximation of a solid ring, the individual magnets need to be as close as possible.

Homogeneity

There are a number of considerations in regard to obtaining a homogeneous field.

The field produced from a small array of magnets will never be perfectly homogeneous, so there needs to be a way of characterising the field's homogeneity. This can be done by looking at the Taylor expansion of the field at the point a .

$$B_{\text{Taylor}}(z) = c_0 + c_1(z-a) + c_2(z-a)^2 + c_3(z-a)^3 + c_4(z-a)^4 + \dots$$

$$c_n = \frac{B^{(n)}(a)}{n!}$$

where $B^{(n)}$ is the n th derivative of B .

The expression $B_{\text{Taylor}}(z)$ describes the field in a region around the point a . The c_0 coefficient gives the strength of the field and the coefficients c_1, c_2, \dots describe the inhomogeneity in the region. The first non-zero term will always be the dominant one that destroys the homogeneity. By manipulating the source of the field so that the first few coefficients are zero, a quasi-uniform field will result.

The well-known configuration of 'Helmholtz coils' does exactly that. Due to symmetry, the odd coefficients are zero but also the second order term. This leaves us with the first non-zero term c_4 so we have 'fourth order' field.

To generate a remote field of sufficient homogeneity we use a magnetic assembly 9 having a series of cylindrical magnets 1 arranged in a ring with a single permanent magnet 7 in the middle as illustrated in Figure 2. The dimensions of magnets that make up the ring, and the number of magnets can be varied. The dimensions of the middle magnet can also be varied, but the position is determined by the 'homogeneity condition', that is, there is one specific placement of the central magnet which results in there being one point on the z -axis (or longitudinal axis) where the 1st and 2nd derivatives are zero.

It is preferable that the position of the central magnet relative to the array of surrounding magnets is adjustable. Adjustment of the central magnet along the z -axis relative to the array of primary magnets is particularly useful when taking measurements in concrete which contains reinforcing mesh. In the case of reinforcing steel in concrete, even if the magnet array is placed symmetrically above or in line with a square of the mesh (rather than above or in line with an intersection of wires), the distortion of the field is such that the homogeneity will be lost. However, if the assembly allows for ready adjustment of the

position of the central magnet along the z -axis, the homogeneity can be restored. It has been found that the homogeneity can be restored by moving the central magnet by about 1-2 mm along the z -axis in an apparatus having dimensions similar to those outlined in the following calculation.

Example Homogeneity Calculation

For example, we choose 8 magnets with magnetisation 1.20 T, length 4.00cm, radius 1.00cm and arranging them axially in a cylinder about the z -axis so they are as close as possible. If we place a central magnet of the same dimensions in the middle, the homogeneity condition if the central magnet is placed at $z = -2.62$ cm. This gives a depth of 0.91cm and a strength of 0.137 T, as illustrated in Figure 3. Figure 3 is a graph illustrating the homogeneous region obtained from a ring with a central magnet as shown in Figure 2.

Arrangement of the Magnets in the Array

A further advantage of the use of a plurality of cylindrical magnets is that these can be angled inwards or outwards to give a distinctive cone shape. This is the second important feature of our apparatus.

Figure 4 is a schematic illustrating the tilting of the primary magnets 1 of the array to provide a cone shape. The outer magnets that make up the ring in the magnetic assembly 11 are tilted by an angle β to give the "cone shape".

Tilted Ring design

The strength and depth achieved by a ring will depend on the size of the magnets and the angle at which they are tilted. Greater depths are achieved when the magnets are tilted outwards, i.e. β is positive.

It is useful to describe the size of array in a dimensionless form using the radius, r , as the scaling parameter. Figures 9 and 10 show the strength of the uniform region and the scaled depth of this region for different angles (the magnets are tilted outwards) and different scaled lengths.

It is apparent that as the angle β increases, the strength of the uniform region goes down and the depth goes up and appears to be a direct trade off. Angles between .33 and .82 Radians appear suitable. The most favourable length to radius ratio is not immediately clear, values between 2 and 4 contain a maximum in Figure 9 through most angles and seem the best choice. At most angles, the strength decreases slightly above a length/r ratio of approximately 2.5. It can be seen from Figure 10 that once β is larger than 0.5, the depth increases with a length/r as well.

The dimensions stated in the "Design Example" below are shown as an "x" in both graphs.

While not essential, it is preferable to construct the magnet ring in such a way that the outside magnets are as close as they can be. Because the 'depth' refers to the distance from the homogeneous region to the magnet, it makes sense to place the magnet array so that the top of the magnets are at $z = 0$. Both of these conditions are met if the magnets are arranged as illustrated in Figure 4a.

With reference to Figure 4a, to ensure that the top of the ring is at $z = 0$ and that the magnets are as close as they can be, R and t are calculated as follows:

$$R = r|\cos \beta| \sqrt{1 + \frac{1}{\tan^2 \frac{\pi}{N} \cos^2 \beta}} + l|\sin \beta|$$

$$t = \sqrt{r^2 + \left(\frac{l}{2}\right)^2} \max(|\cos(\beta - \phi)|, |\cos(\beta + \phi)|)$$

where

$$\phi = \tan^{-1}\left(\frac{2r}{l}\right)$$

N is the number of magnets used,

r is the radius of the magnets

l is the length of the magnets

β is the 'cone angle'

R is the 'ring radius' and

l is the distance along the z -axis from the front of the array to the geometric centres of the magnets.

Figure 4b illustrates the resultant z -axis field profile.

Figures 5a and 5b illustrates a magnetic assembly 13 having a cone shaped array of primary magnets 1 with a central magnet 7. The central magnet is placed so that there is a homogeneous region at some z . Figure 6 illustrates the z -axis field profile for such an arrangement.

For every ring configuration there is a position for the central magnet that will give a homogeneous region as described above. The other parameters, number of magnets, length and radius etc can be adjusted to optimise the depth of the homogenous region or the strength.

Therefore, in general the design of the invention involves placing a number of similar magnets in a ring at some angle (β), and the placing of another magnet in the middle so that there is one point on the z -axis where the 1st and 2nd derivative of the field is zero. This gives a homogenous region.

Design Example

Various designs involve magnets of different sizes, rings of various numbers of magnets and cones with various angles. All of these will produce a homogeneous region of a particular field strength and at a particular depth. For a one sided access-NMR application, a field strength of 0.01 T might be required. This can be realised with an array of magnets as shown below:

$$r = 1.80\text{cm}$$

$$l = 5.00\text{cm}$$

$$\beta = 37.2^\circ$$

$$N = 8$$

This gives

$$R = 6.09\text{cm}$$

$$t = 3.05\text{cm}$$

and the central magnet (of the same dimensions) at $z = -3.27\text{cm}$ (distance to the centre of the central magnet).

The homogenous region is at $z = 5.25\text{cm}$ with a field strength 0.0127 T . Figure 7 shows a magnetic assembly 15 having a magnet array that will provide a homogeneous region at a depth of 5.25cm with a field strength of 0.0127T . The field is illustrated in Figure 8. The uniform region is centred around the "x" in the Figure.

Depth Considerations:

The depth of the subject area, into a sample, that can be studied depends upon (assuming a constant number of magnets) the angle, β , the length to radius ratio and the required field strength.

With reference to the above example, if β was kept constant and the length to radius ratio was increased, the depth would also increase, as shown in Figure 10. It is important to note that the strength of the B field will start to decrease as the length to radius ratio gets larger than about 2.7, as shown in Figure 9.

In practice, the depths we will be dealing with are up to 10cm . In general, if the angle and the ratio are fixed, the depth will scale with the size of the magnets, i.e. double the dimensions of the magnets, double the depth.

Figure 11 shows a modified magnetic apparatus 17 in which the faces 19 of the array of magnets 1 are truncated, so that the faces 19 of the magnets can sit flush with the surface of the material to be analysed. This improves the efficiency of the apparatus, due to reduced spacing between the magnets and the material.

Excitation of Separate "Slices" or "Volumes"

The direct relationship between magnetic field intensity and NMR frequency means that the field profile associated with the magnet configurations described here necessarily corresponds to a frequency profile for the nuclear spins being excited in the NMR measurement. In particular, the range of frequencies present in the excitation pulse (the pulse bandwidth) will determine the spatial range of spins excited in the region of nearly uniform magnetic field. This bandwidth is in turn limited by the rf power available in the transmitter. Thus the largest region of spins, and hence the strongest signal will be obtained, when the rf power is at a maximum.

The relationship between rf pulse power and field uniformity thus determines the spatial extent of the region of sample excited in the NMR measurement and also the size of the signal measured and hence the intrinsic sensitivity of the experiment.

Repetition of the rf excitation pulse, and hence the sensitivity advantage which comes from repeating and adding many independently acquired signals (signal averaging) is limited by the need for the nuclear spins to relax back to thermal equilibrium, a process which takes on the order of 0.1 s to 10 s, depending on the sample.

To further increase the signal sensitivity or to further extend the region of sample from which the signal is acquired, the technique of successively switching the transmitter and receiver frequencies on successive excitations and acquisitions will be effective. With each successive excitation, the rf excitation frequency will be changed so as to excite a contiguous slice, cyclically stepping the region of spins excited through adjacent slices. Provided that the total time allowed before repeating excitation on the same slice is sufficient for relaxation, this process may be take place rapidly with successive slices being examined in times much less than the relaxation time. In this way the fundamental efficiency of the measurement is improved. Furthermore by suitable multiplexing, information from different spatial regions may be separated to give spatial profiling.

This switching technique depends on switching the tuning frequency of the rf coils, a technique which depends on electronic switching between differing tuning elements (capacitors).

Accordingly, the apparatus is preferably arranged to generate a sufficiently homogeneous magnetic field over a volume V_a located at a location along the z-axis in the material thereby causing excitation of subject nuclei in the volume V_a , and to detect radio frequency emissions from the subject nuclei in the volume V_a . The apparatus is preferably arranged to, substantially immediately following excitation of volume V_a , cause excitation of subject nuclei in a volume V_b , wherein V_b is a volume differing from V_a only in its position along the longitudinal axis, and to detect radio frequency emissions from the subject nuclei in the volume V_b .

Applications:

The NMR apparatus of the invention has a large number of applications. The preferred embodiment employs a number of "off the shelf" cylindrical magnets which can be any of a number of proportions. It is envisaged the most common of these will be smaller magnets to provide a portable NMR Probe for various applications (however, the invention is not restricted to portable probes).

All applications will include the use of such apparatus to study liquid phases (whether in a solid phase, or within other liquid phases). Such applications include moisture studies. Specific examples are:

- moisture content of soil;
- moisture levels in buildings;
- moisture content of timber and logs;
- location of knots and defects in timber and logs;
- drug detection in humans;
- in-vivo spectroscopy on humans and animals;
- moisture analysis of packaged food.

One particular example is the application of the probe to studies of the curing of concrete as outlined below.

Example:

Concrete is a mixture of water, cement, sand and gravel. The water is contained in three different states, chemically bound, capillary bound and free water. During the curing process, the relative fraction of these three states changes as water evaporates from the surface. The moisture content of the concrete gives an indication of its strength and readiness to accept floor coverings. Presently there is no reliable way of measuring this.

The one sided access NMR probe of the preferred embodiment of the invention provides a convenient way of measuring the moisture. One part of such a probe is achieving a homogenous magnetic field B_0 at a useful depth of approximately 5cm.

Where in the foregoing description reference has been made to elements or integers having known equivalents, then such equivalents are included as if they were individually set forth.

Although the invention has been described by way of example and with reference to particular embodiments, it is to be understood that modifications and/or improvements may be made without departing from the scope or spirit of the invention.

For example, the magnet elements need not be cylinders but perhaps some other convenient shape. The arrangement of the elements will preferably be such that their magnetisations form a "cone-shape" at some angle (i.e. the axis between the north and south poles within the magnet is at a non-parallel angle to the longitudinal axis), and it is this angle that will determine the position of the central magnet such that the homogeneity condition is met. However, it should be noted that the expressions for R and t above only apply to cylindrical magnets. As an example, an array could be constructed out of blocks which are aligned with the axis, but the magnetisation of each block in the array could be arranged so that the array forms the "cone-shape".

The preferred apparatus are described as having 8 primary magnets in the array. More or less magnets could be used as desired. However, an array of 8 magnets has been found to provide good coverage of magnetic material.

CLAIMS

1. A magnetic assembly for an NMR apparatus, comprising a plurality of primary permanent magnets disposed in an annular array about an axis (hereafter "longitudinal axis"), wherein each of the magnets has a north pole and a south pole with an axis extending therebetween, and each of the primary magnets is arranged such that its axis is oriented at a non-parallel angle to the longitudinal axis of the assembly, the assembly further comprising a secondary permanent magnet located on the longitudinal axis, at a position at least partly within the array of primary magnets, with the non-parallel angles of the primary magnet axes and the position of the secondary magnet selected to create a zone of homogeneous magnetic field at a location along the longitudinal axis forward of the array, and into a material when provided.
2. A magnetic assembly as claimed in claim 1, wherein the position of the secondary permanent magnet is adjustable along the longitudinal axis relative to the primary magnets.
3. A magnetic assembly as claimed in claim 1 or 2, wherein the secondary magnet is a cylindrical bar magnet.
4. A magnetic assembly as claimed in any one of claims 1 to 3, wherein the secondary magnet is positioned such that the first and second spatial derivatives of the magnetic field are zero at some coincident location along the longitudinal axis forward of the array, and into the material when provided.
5. A magnetic assembly as claimed in any one of claims 1 to 4, wherein each of the plurality of primary magnets is a cylindrical bar magnet, each having a proximal end at a front of the array, and a distal end at a rear of the array.
6. A magnetic assembly as claimed in claim 5, wherein each of the plurality of primary magnets is tilted at an angle relative to the longitudinal axis, such that the configuration of magnets is in a substantially symmetrical tapered arrangement.

7. A magnetic assembly as claimed in claim 6, wherein the tapered arrangement is according to the expression:

$$R = r|\cos \beta| \sqrt{1 + \frac{1}{\tan^2 \frac{\pi}{N} \cos^2 \beta}} + |l \sin \beta|$$

$$t = \sqrt{r^2 + \left(\frac{l}{2}\right)^2} \max(|\cos(\beta - \phi)|, |\cos(\beta + \phi)|)$$

where

$$\phi = \tan^{-1}\left(\frac{2r}{l}\right)$$

N is the number of magnets used,

r is the radius of the magnets,

l is the length of the magnets,

β is the 'cone angle',

R is the 'ring radius',

and t is the distance along the longitudinal axis from the front of the array to the geometric centre of the magnets.

8. A magnetic assembly as claimed claim 6 or 7, wherein the proximal end of each of the plurality of primary magnets is tilted through an angle beta towards the longitudinal axis, such that the configuration of primary magnets is in a substantially symmetrical tapered arrangement, tapering towards the front of the array.

9. A magnetic assembly as claimed in claim 6 or 7, wherein the proximal end of each of the plurality of primary magnets is tilted through an angle beta away from the longitudinal axis, such that the configuration of primary magnets is in a substantially symmetrical tapered arrangement, tapering away from the front of the array.

10. A magnetic assembly as claimed any one of the preceding claims, wherein the plurality of primary magnets is disposed substantially symmetrically about the longitudinal axis.

11. A magnetic assembly as claimed in any one of the preceding claims, wherein the primary magnets are as close together as is physically or reasonably possible.
12. A magnetic assembly as claimed in any one of the preceding claims, wherein each of the plurality of primary magnets is substantially identical.
13. A magnetic assembly as claimed in claim 12, wherein the secondary magnet is of substantially identical dimensions to each of the plurality of primary magnets.
14. A magnetic assembly as claimed in claim 13, wherein each of the plurality of primary magnets and the secondary magnet is a cylindrical bar magnet having a radius of about 1.8cm and a length of about 5cm.
15. A magnetic assembly as claimed in any one of the preceding claims, comprising eight primary magnets.
16. A nuclear magnetic resonance apparatus for one sided access investigations of a material, comprising a magnetic assembly as claimed in any one of the preceding claims.
17. A nuclear magnetic resonance apparatus as claimed in claim 16, wherein the nuclear magnetic resonance apparatus is portable.
18. A nuclear magnetic resonance apparatus as claimed in claim 16 or 17, operable to provide investigations into a sample at up to about 10cm.
19. A nuclear magnetic resonance apparatus as claimed in any one of claims 16 to 18, wherein the apparatus is operable in such a fashion as to allow excitation of one volume V_a of the material, being one of a plurality of volumes V_1 to V_n , existing as slices along the longitudinal axis.

20. A nuclear magnetic resonance apparatus as claimed in claim 19, wherein the apparatus is operable to, following excitation of V_a then allow excitation of a second volume V_b being one of the plurality of volumes V_1 to V_n substantially immediately after excitation of V_a without moving the apparatus, by varying an excitation frequency of the apparatus.

21. A nuclear magnetic resonance apparatus for one sided access investigations of a material, including a plurality of primary permanent magnets disposed in an annular array about an axis (hereafter "longitudinal axis"), and a secondary permanent magnet located on the longitudinal axis, at least partly within the array of primary magnets, the position of the secondary permanent magnet being adjustable along the longitudinal axis relative to the primary magnets, to create a zone of homogeneous magnetic field at a location along the axis forward of the array, and into a material when provided.

22. A method of studying the magnetic resonance of a material including the steps of:

- a) employing an NMR apparatus as claimed in any one of claims 16 to 21;
- b) generating a sufficiently homogeneous magnetic field over a volume V_a located at a location along the longitudinal axis in the material thereby causing excitation of subject nuclei in the volume V_a ; and
- c) detecting radio frequency emissions from the subject nuclei in the volume V_a .

23. A method of studying the magnetic resonance of a material as claimed in claim 22, comprising or including, subsequent to step c):

- d) substantially immediately following excitation of volume V_a , causing excitation of subject nuclei in a volume V_b , wherein V_b is a volume differing from V_a only in its position along the longitudinal axis, wherein said excitation of volume V_b occurs without moving the apparatus from the position in which volume V_a is excited, by varying an excitation frequency of the apparatus; and
- e) detecting radio frequency emissions from the subject nuclei in the volume V_b .

1/12

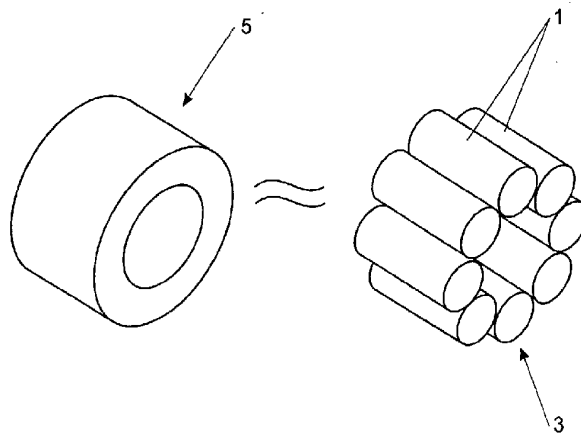

FIGURE 1

2/12

FIGURE 2

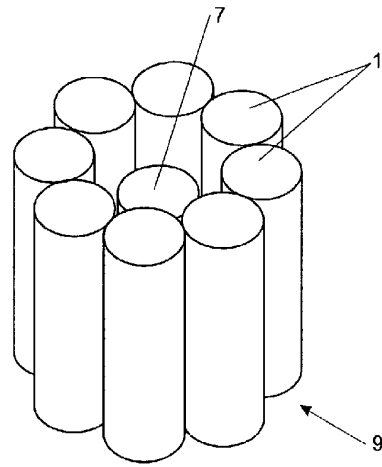
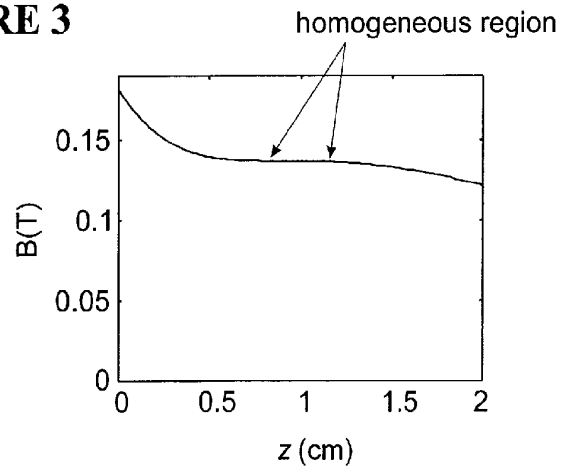

FIGURE 3



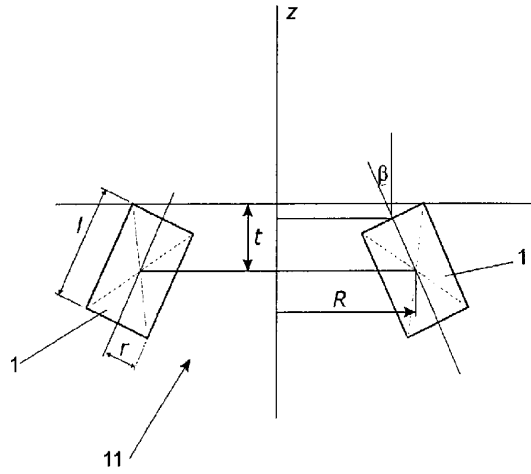

FIGURE 4a

4/12

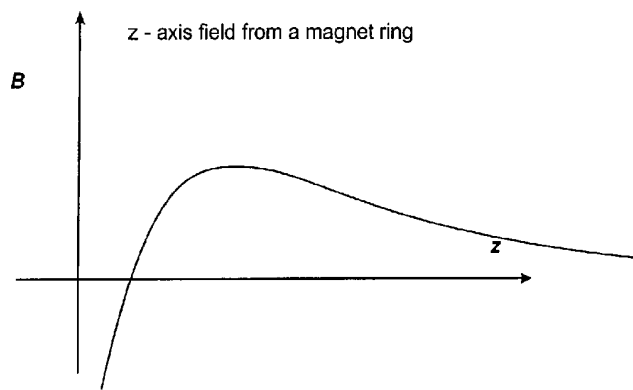

FIGURE 4b

5/12

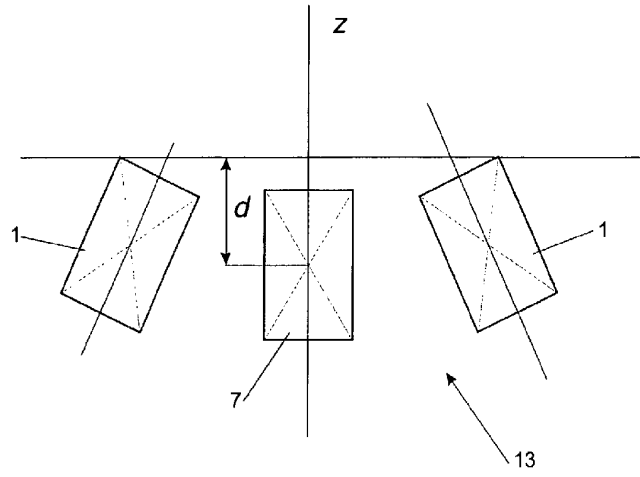

FIGURE 5a

6/12

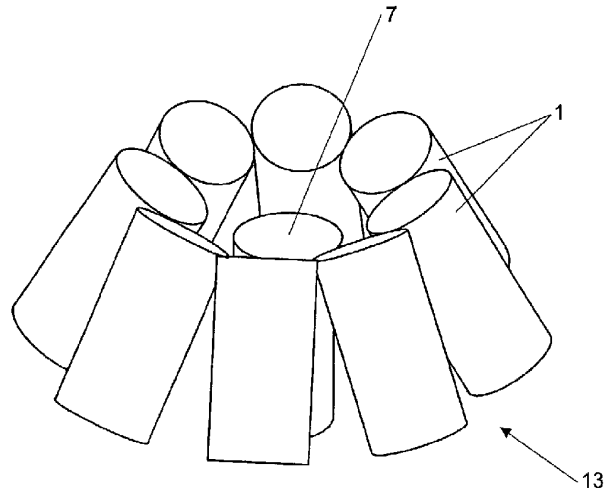

FIGURE 5b

7/12

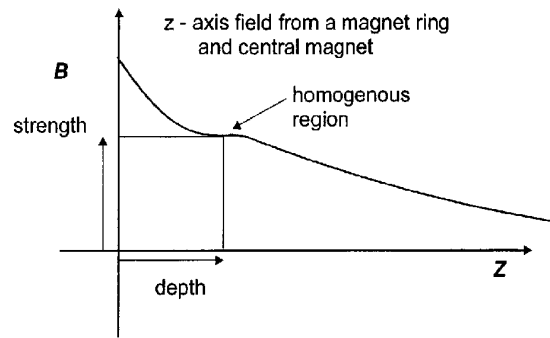

FIGURE 6

8/12

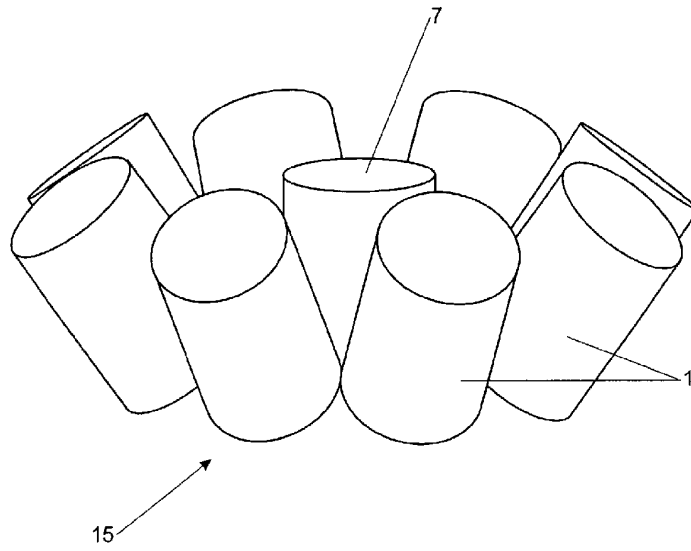

FIGURE 7

9/12

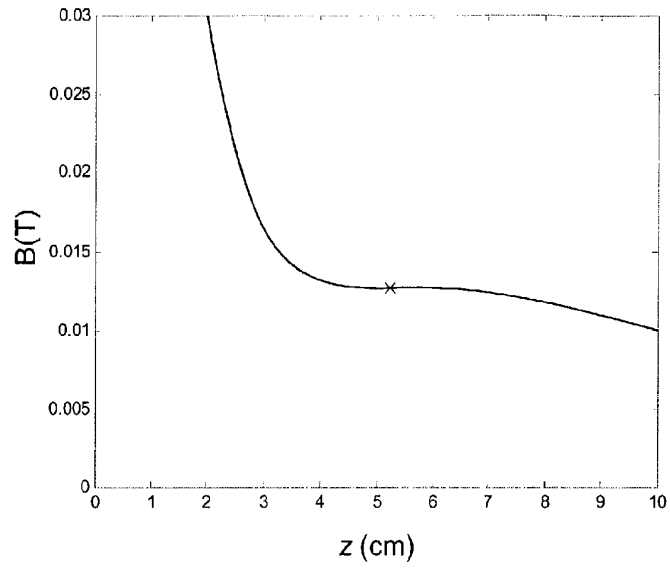

FIGURE 8

10/12

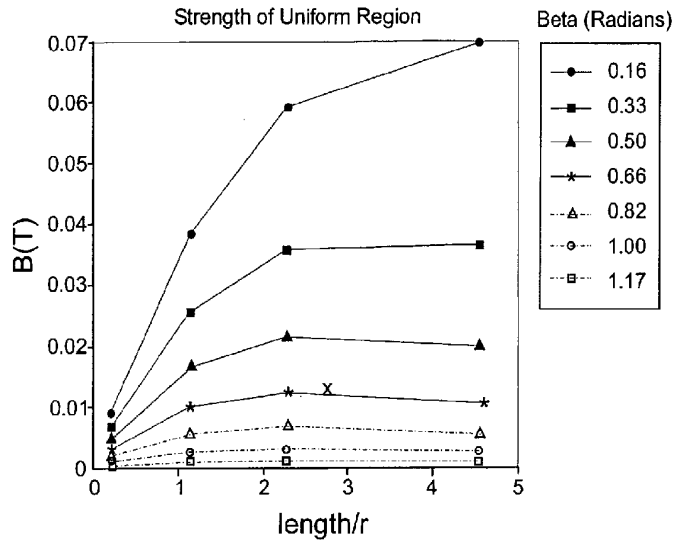

FIGURE 9

11/12

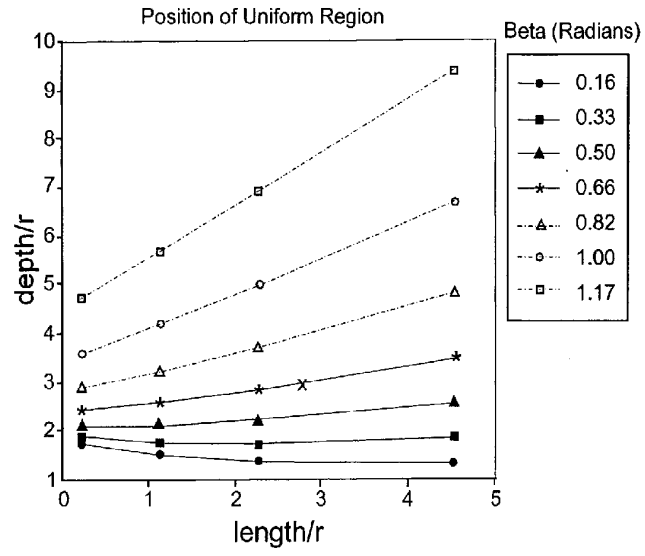

FIGURE 10

12/12

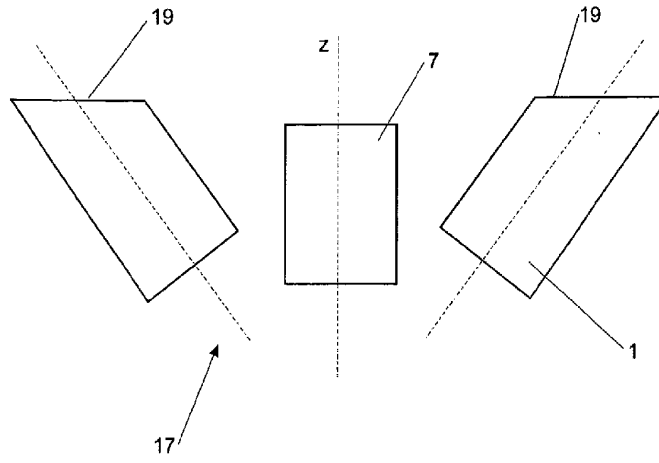

FIGURE 11