

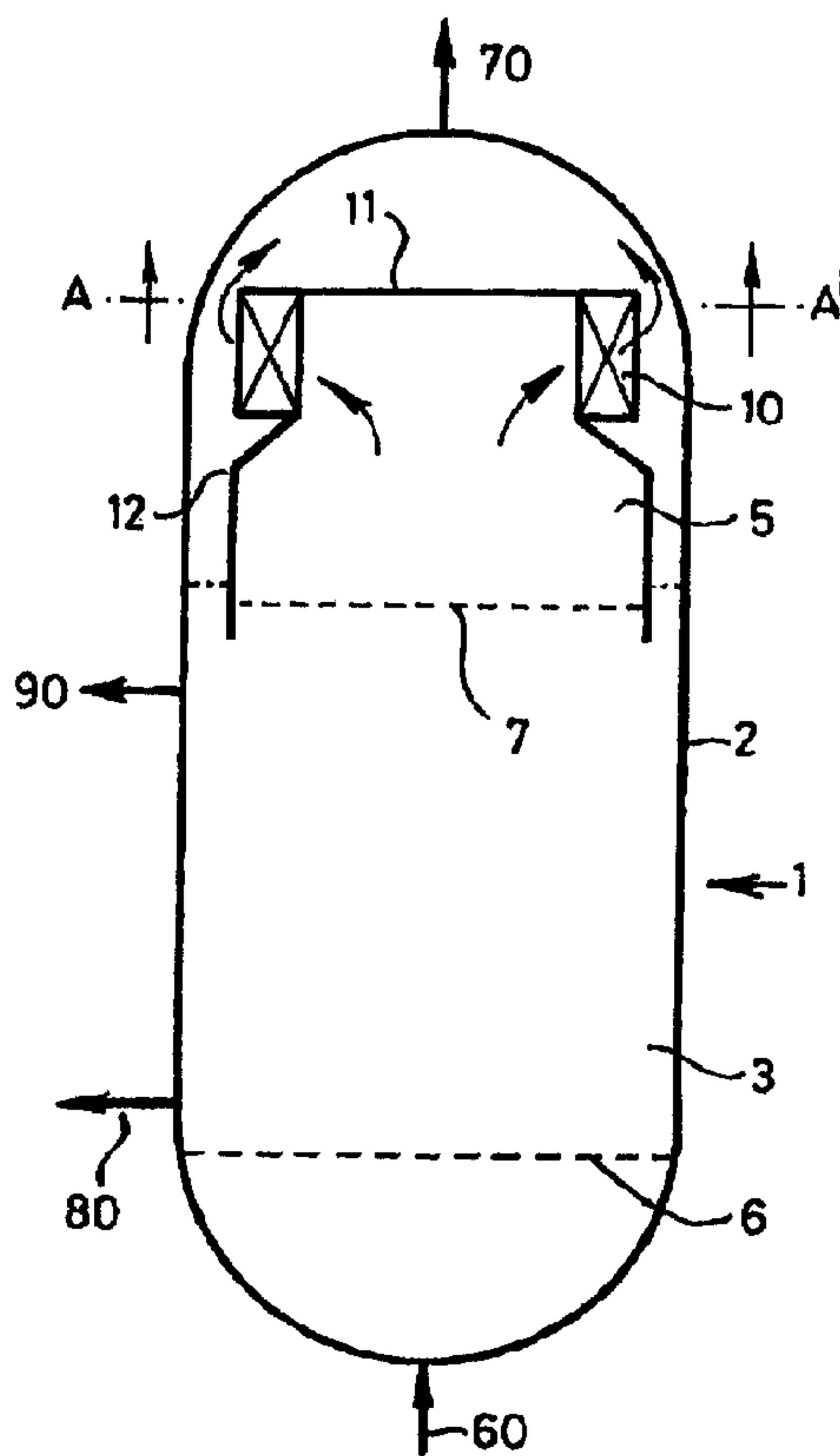

(86) Date de dépôt PCT/PCT Filing Date: 1997/08/07  
 (87) Date publication PCT/PCT Publication Date: 1998/02/19  
 (45) Date de délivrance/Issue Date: 2005/11/22  
 (85) Entrée phase nationale/National Entry: 1999/01/26  
 (86) N° demande PCT/PCT Application No.: EP 1997/004404  
 (87) N° publication PCT/PCT Publication No.: 1998/006487  
 (30) Priorité/Priority: 1996/08/08 (96202235.6) EP

(51) Cl.Int.<sup>6</sup>/Int.Cl.<sup>6</sup> B01J 8/22, C10G 2/00  
 (72) Inventeurs/Inventors:  
 HOEK, AREND, NL;  
 VAN DER HONING, GEERT, NL;  
 LAURIJSEN, JOHANNES GERARDUS, NL;  
 SENDEN, MATHIJS MARIA GERARDUS, NL  
 (73) Propriétaire/Owner:  
 SHELL INTERNATIONALE RESEARCH  
 MAATSCHAPPIJ B.V., NL  
 (74) Agent: OGILVY RENAULT LLP/S.E.N.C.R.L.,S.R.L.

(54) Titre : PROCÉDE ET REACTEUR POUR EFFECTUER UNE REACTION EXOTHERMIQUE  
 (54) Title: PROCESS AND REACTOR FOR CARRYING OUT AN EXOTHERMIC REACTION



(57) Abrégé/Abstract:

The present invention relates to a process for carrying out an exothermic reaction in the presence of a solid catalyst in a three-phase slurry reactor (1) comprising a slurry zone (3) and a freeboard zone (5), in which slurry zone (3) the catalyst is kept in suspension in a slurry liquid, and in which freeboard zone (5) a liquid reflux is maintained to remove catalyst from the freeboard zone and, preferably, recycling the catalyst to the slurry zone (3). According to a further aspect, the present invention relates to a three-phase slurry reactor (1) adapted to the process, in particular a three-phase slung reactor (1) wherein the freeboard zone (5) contains means to trap catalyst particles (10).



PCT

WORLD INTELLECTUAL PROPERTY ORGANIZATION  
International Bureau

## INTERNATIONAL APPLICATION PUBLISHED UNDER THE PATENT COOPERATION TREATY (PCT)

<p>(51) International Patent Classification <sup>6</sup> : B01J 8/22, C10G 2/00, B01J 8/00</p>	A1	<p>(11) International Publication Number: <b>WO 98/06487</b> (43) International Publication Date: 19 February 1998 (19.02.98)</p>
<p>(21) International Application Number: PCT/EP97/04404 (22) International Filing Date: 7 August 1997 (07.08.97)</p> <p>(30) Priority Data: 96202235.6 8 August 1996 (08.08.96) EP (34) Countries for which the regional or international application was filed: GB et al.</p> <p>(71) Applicant: SHELL INTERNATIONALE RESEARCH MAATSCHAPPIJ B.V. [NL/NL]; Carel van Bylandtlaan 30, NL-2596 HR The Hague (NL).</p> <p>(72) Inventors: HOEK, Arend; Badhuisweg 3, NL-1031 CM Amsterdam (NL). VAN DER HONING, Geert; Badhuisweg 3, NL-1031 CM Amsterdam (NL). LAURIJSSSEN, Johannes, Gerardus; Carel van Bylandtlaan 30, NL-2596 HR The Hague (NL). SENDEN, Mathijs, Maria, Gerardus; Carel van Bylandtlaan 30, NL-2596 HR The Hague (NL).</p>		<p>(81) Designated States: AU, CA, JP, NO, European patent (AT, BE, CH, DE, DK, ES, FI, FR, GB, GR, IE, IT, LU, MC, NL, PT, SE).</p> <p><b>Published</b> <i>With international search report. Before the expiration of the time limit for amending the claims and to be republished in the event of the receipt of amendments.</i></p>

(54) Title: PROCESS AND REACTOR FOR CARRYING OUT AN EXOTHERMIC REACTION

## (57) Abstract

The present invention relates to a process for carrying out an exothermic reaction in the presence of a solid catalyst in a three-phase slurry reactor (1) comprising a slurry zone (3) and a freeboard zone (5), in which slurry zone (3) the catalyst is kept in suspension in a slurry liquid, and in which freeboard zone (5) a liquid reflux is maintained to remove catalyst from the freeboard zone and, preferably, recycling the catalyst to the slurry zone (3). According to a further aspect, the present invention relates to a three-phase slurry reactor (1) adapted to the process, in particular a three-phase slurry reactor (1) wherein the freeboard zone (5) contains means to trap catalyst particles (10).

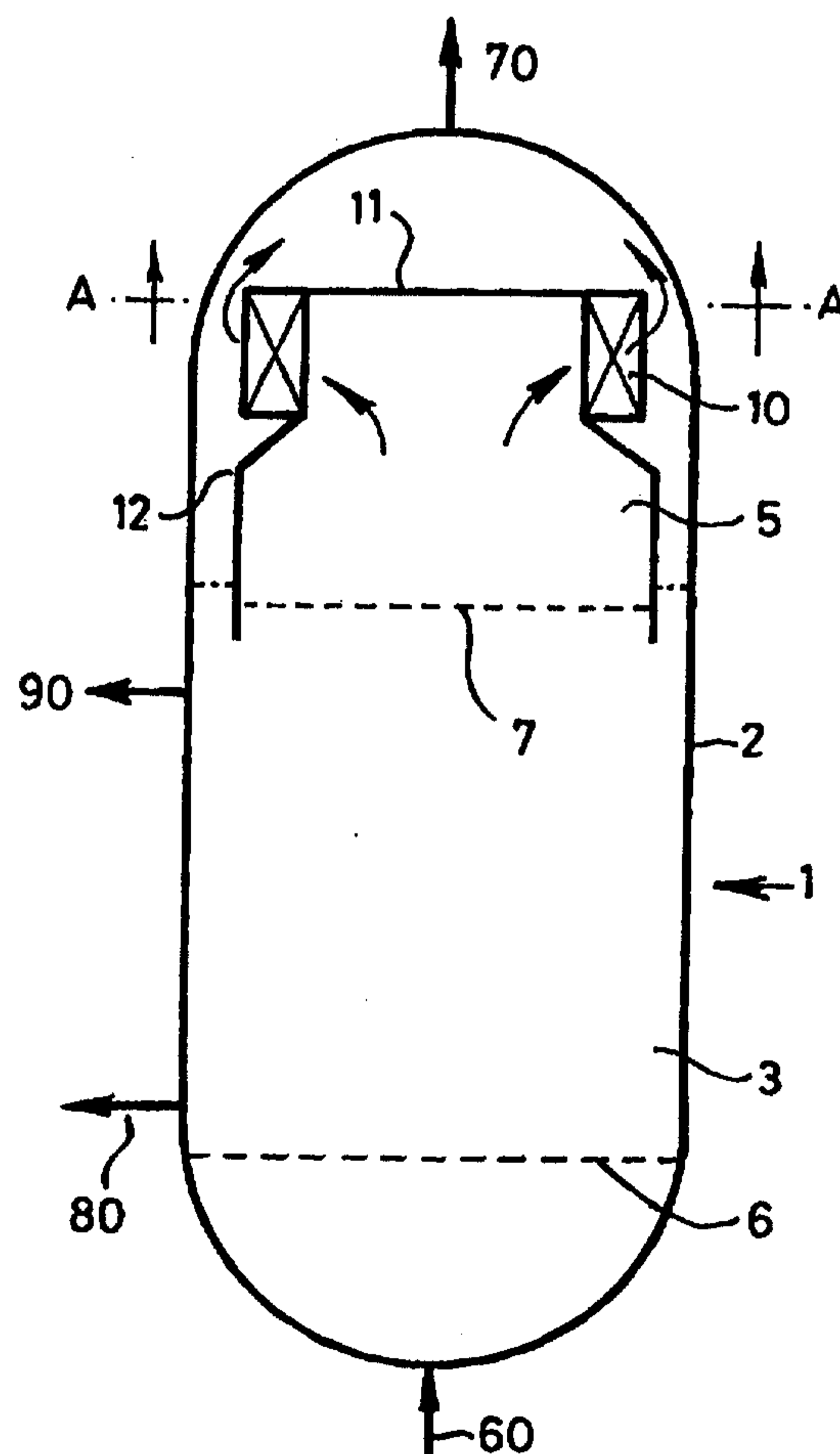

- 1 -

PROCESS AND REACTOR FOR CARRYING OUT  
AN EXOTHERMIC REACTION

The present invention relates to a process for carrying out an exothermic reaction in the presence of a solid catalyst in a three-phase slurry reactor. According to a further aspect, the present invention relates to a  
5 three-phase slurry reactor for carrying out an exothermic reaction.

Three-phase slurry reactors are well known to those skilled in the art. In operation, the said reactor comprises a slurry zone and a freeboard zone. The  
10 freeboard zone is located within the reactor, above the slurry zone. In the slurry zone solid catalyst particles are kept in suspension in a liquid. The liquid serves as heat-transfer medium. The mixture of catalyst particles and liquid is commonly referred to as slurry. One or more  
15 gaseous reactants bubble through the slurry zone. The freeboard zone located above the slurry zone contains substantially no slurry and serves as a disengagement zone between slurry, and gaseous products and reactants.

The catalyst particles are typically kept in  
20 suspension by stirring or agitation by a mechanical device or, preferably, by an upward gas and/or liquid velocity.

Although substantially all catalyst particles are present in the slurry zone, a proportion of the catalyst  
25 particles escape from the slurry zone into the freeboard zone and may stick to the reactor wall or internals in the freeboard zone. In the absence of liquid heat-transfer medium, but in the presence of unreacted gaseous

- 2 -

reactants, the said catalyst particles continue to catalyse the exothermic reaction. In this way, local hot spots are created which may damage the reactor vessel and/or internals.

5           Accordingly, it would be desirable to be able to remove catalyst particles efficiently from the freeboard zone.

10           For the purposes of this specification the term catalyst particles is intended as reference to catalyst particles per se and/or any fines thereof.

15           Therefore, the present invention relates to a process for carrying out an exothermic reaction in the presence of solid catalyst particles in a three-phase slurry reactor comprising a slurry zone and a freeboard zone, in which slurry zone the catalyst particles are kept in suspension in a slurry liquid, which freeboard zone contains catalyst particles escaped from the slurry zone, and in which freeboard zone a liquid reflux is maintained to remove the catalyst particles from the freeboard zone.  
20           Preferably, the catalyst particles in the freeboard zone are recycled to the slurry zone by means of the liquid reflux.

25           The liquid reflux can be generated and maintained by spraying liquid into the freeboard zone from an external source.

          The liquid reflux is typically inert, that is the liquid reflux is not a reactant for the exothermic reaction and substantially does not react to other products in the process.

30           In one preferred embodiment, the liquid reflux from the external source is a part of the slurry liquid which is withdrawn from the slurry zone. Following separation of the said liquid from the solid particles by means

- 3 -

known to those skilled in the art, a part of the said liquid is introduced into the freeboard zone.

According to another preferred embodiment of the invention, the exothermic reaction produces at least some gaseous products, which gaseous products are capable of at least partly condensing at a temperature between the reaction temperature in the top part of the slurry zone and 50 °C below the said reaction temperature, and the liquid reflux is generated and maintained by at least partly condensing the gaseous product in the freeboard zone.

Optionally, a combination of the above methods is employed to maintain the liquid reflux.

The gaseous products may at least partly be condensed by means known to those skilled in the art. Thus, in one embodiment the gaseous products are at least partly condensed by external cooling of the wall surrounding the freeboard zone, typically the reactor wall.

According to another embodiment, the gaseous products are at least partly condensed by allowing more leakage of heat from the freeboard zone of the reactor to the atmosphere, than from the slurry zone. This can suitably be achieved by less thermal insulation in the reactor wall surrounding the freeboard zone, relative to the reactor wall surrounding the slurry zone.

According to yet another embodiment, the gaseous products are at least partly condensed by cooling means in the freeboard zone. A variety of known cooling means may be applied, including indirect cooling means such as cooling coils.

However, a disadvantage of indirect cooling means, such as cooling coils, present in the freeboard zone is that in this way the volume of the freeboard zone

- 4 -

occupied by internals is relatively high. Thus, the chance that a catalyst particle escaping from the slurry zone sticks to an internal in the freeboard zone, is high as well. It will be appreciated that according to a preferred embodiment, the volume of the freeboard zone occupied by internals is minimised.

Accordingly, in one preferred embodiment, the cooling in the freeboard zone is achieved by injection of a relatively cold gas, typically an inert gas. More preferably, cooling is achieved by injection of a liquid which vaporises under conditions prevailing in the freeboard zone. Thus, in this embodiment, the cooling means in the freeboard zone typically comprises gas or liquid injection means.

The cooling means in the freeboard zone is preferably controllable independent from the cooling means present in the slurry zone.

The slurry zone can be cooled by direct or indirect cooling means. For the purposes of this specification, direct cooling means refers to those means where the cooling medium is in direct contact with the slurry in the slurry zone. Indirect cooling means refers to those means where the cooling medium is not in direct contact with the slurry in the slurry zone. An example of the latter is an arrangement of cooling tubes immersed in the slurry. Preferably, the slurry zone is cooled by indirect cooling means.

It will be appreciated that in order to minimise the volume of internals present in the freeboard zone, preferably any indirect cooling means used to cool the slurry zone, hereinafter indirect slurry cooling means, substantially do not extend into the freeboard zone.

- 5 -

Preferably, the average temperature in the freeboard zone is decreased to a temperature which is up to 50 °C lower than the temperature in the top of the slurry zone. The temperature in the top of the slurry zone is typically the average temperature prevailing at about 5 to 15 cm below the interface between the slurry zone and the freeboard zone. More preferably, the decrease is up to 30 °C.

The temperature in the freeboard zone is preferably decreased by at least 5 °C, more preferably at least 10 °C, relative to the temperature in the top of the slurry zone.

It will however be understood by those skilled in the art that the desired temperature decrease depends on a variety of factors such as the quantity of condensing product at a certain temperature; the amount of catalyst particles, or fines thereof, which is present in the freeboard zone; the complexity of, and volume occupied by, internals in the freeboard zone; and the average particle size of catalyst particles or fines present in the freeboard zone. Thus, it will be appreciated, it may sometimes be preferred to decrease the temperature more or less than the preferred ranges given above.

The average particle size of the catalyst particles may vary between wide limits, depending inter alia on the type of slurry zone regime. Typically, the average particle size may range from 1 µm to 2 mm, preferably from 1 µm to 1 mm.

If the average particle size is greater than 100 µm, and the particles are not kept in suspension by a mechanical device, the slurry zone regime is commonly referred to as an ebullating bed regime. Preferably, the average particle size in an ebullating bed regime is less

- 6 -

than 600  $\mu\text{m}$ , more preferably in the range from 100 to 400  $\mu\text{m}$ . It will be appreciated that in general the larger the particle size of a particle, the smaller the chance that particle escapes from the slurry zone into the freeboard zone. Thus, if an ebullating bed regime is employed, primarily fines of catalyst particles will escape to the freeboard zone.

If the average particle size is at most 100  $\mu\text{m}$ , and the particles are not kept in suspension by a mechanical device, the slurry zone regime is commonly referred to as a slurry phase regime. Preferably, the average particle size in a slurry phase regime is more than 5  $\mu\text{m}$ , more preferably in the range from 10 to 75  $\mu\text{m}$ .

If the particles are kept in suspension by a mechanical device, the slurry zone regime is commonly referred to as stirred tank regime. It will be appreciated that in principle any average particle size within the above ranges can be applied. Preferably, the average particle size is kept in the range from 1 to 200  $\mu\text{m}$ .

The concentration of catalyst particles present in the slurry may range from 5 to 45% by volume, preferably, from 10 to 35% by volume. It may be desired to add in addition other particles to the slurry, as set out in for example European patent application publication No. 0 450 859. The total concentration of solid particles in the slurry is typically not more than 50% by volume, preferably not more than 45% by volume.

Suitable slurry liquids are known to those skilled in the art. Typically, at least a part of the slurry liquid is a reaction product of the exothermic reaction. Preferably, the slurry liquid is substantially completely a reaction product.

- 7 -

The exothermic reaction is a reaction which is carried out in the presence of a solid catalyst, and which is capable of being carried out in a three-phase slurry reactor. Typically, at least one of the reactants of the exothermic reaction is gaseous. Examples of exothermic reactions include hydrogenation reactions, hydroformylation, alkanol synthesis, the preparation of aromatic urethanes using carbon monoxide, Kölbel-Engelhardt synthesis, polyolefin synthesis, and Fischer-Tropsch synthesis. According to a preferred embodiment of the present invention, the exothermic reaction is a Fischer-Tropsch synthesis reaction.

The Fischer-Tropsch synthesis is well known to those skilled in the art and involves synthesis of hydrocarbons from a gaseous mixture of hydrogen and carbon monoxide, by contacting that mixture at reaction conditions with a Fischer-Tropsch catalyst.

Products of the Fischer-Tropsch synthesis may range from methane to heavy paraffinic waxes. Preferably, the production of methane is minimised and a substantial portion of the hydrocarbons produced have a carbon chain length of at least 5 carbon atoms. Preferably, the amount of C<sub>5</sub>+ hydrocarbons is at least 60% by weight of the total product, more preferably, at least 70% by weight, even more preferably at least 80% by weight, most preferably at least 85% by weight.

Fischer-Tropsch catalysts are known in the art, and typically include a Group VIII metal component, preferably cobalt, iron and/or ruthenium, more preferably cobalt. Typically, the catalysts comprise a catalyst carrier. The catalyst carrier is preferably porous, such as a porous inorganic refractory oxide, more preferably alumina, silica, titania, zirconia or mixtures thereof.

- 8 -

The optimum amount of catalytically active metal present on the carrier depends inter alia on the specific catalytically active metal. Typically, the amount of cobalt present in the catalyst may range from 1 to 100 parts by weight per 100 parts by weight of carrier material, preferably from 10 to 50 parts by weight per 100 parts by weight of carrier material.

The catalytically active metal may be present in the catalyst together with one or more metal promoters or co-catalysts. The promoters may be present as metals or as the metal oxide, depending upon the particular promoter concerned. Suitable promoters include oxides of metals from Groups IIA, IIIB, IVB, VB, VIB and/or VIIB of the Periodic Table, oxides of the lanthanides and/or the actinides. Preferably, the catalyst comprises at least one oxide of an element in Group IVB, VB and/or VIIB of the Periodic Table, in particular titanium, zirconium, manganese and/or vanadium. As an alternative or in addition to the metal oxide promoter, the catalyst may comprise a metal promoter selected from Groups VIIB and/or VIII of the Periodic Table. Preferred metal promoters include rhenium, platinum and palladium.

A most suitable catalyst comprises cobalt as the catalytically active metal and zirconium as a promoter. Another most suitable catalyst comprises cobalt as the catalytically active metal and manganese and/or vanadium as a promoter.

The promoter, if present in the catalyst, is typically present in an amount of from 0.1 to 60 parts by weight per 100 parts by weight of carrier material, preferably from 0.5 to 40 parts by weight per 100 parts by weight of carrier material. It will however be appreciated that the optimum amount of promoter may vary

- 9 -

for the respective elements which act as promoter. If the catalyst comprises cobalt as the catalytically active metal and manganese and/or vanadium as promoter, the cobalt : (manganese + vanadium) atomic ratio is advantageously at least 12:1.

The Fischer-Tropsch synthesis is preferably carried out at a temperature in the range from 125 to 350 °C, more preferably 175 to 275 °C, most preferably 200 to 260 °C. The pressure preferably ranges from 5 to 150 bar abs., more preferably from 5 to 80 bar abs.

Hydrogen and carbon monoxide (synthesis gas) is typically fed to the three-phase slurry reactor at a molar ratio in the range from 0.4 to 2.5. Preferably, the hydrogen to carbon monoxide molar ratio is in the range from 1.0 to 2.5.

The gaseous hourly space velocity may vary within wide ranges and is typically in the range from 1500 to 10000 Nl/l/h, preferably in the range from 2500 to 7500 Nl/l/h.

The Fischer-Tropsch synthesis is preferably carried out in a slurry phase regime or an ebullating bed regime, wherein the catalyst particles are kept in suspension by an upward superficial gas and/or liquid velocity.

It will be understood that the skilled person is capable to select the most appropriate conditions for a specific reactor configuration and reaction regime.

Preferably, the superficial gas velocity of the synthesis gas is in the range from 0.5 to 50 cm/sec, more preferably in the range from 5 to 35 cm/sec.

Typically, the superficial liquid velocity is kept in the range from 0.001 to 4.0 cm/sec, including liquid production. It will be appreciated that the preferred range may depend on the preferred mode of operation.

- 10 -

According to one preferred embodiment, the superficial liquid velocity is kept in the range from 0.005 to 1.0 cm/sec.

As outlined hereinabove, preferably the volume of the freeboard zone occupied by internals is minimised. In this way, the chance that a catalyst particle escaping from the slurry zone sticks to an internal in the freeboard zone, is minimised as well.

However, it may be preferred that the freeboard zone contains means specifically designed to trap catalyst particles. Such means e.g. may be used for protecting parts of the freeboard zone which are difficult to clean with a liquid reflux or otherwise, for example outlet means for gases.

Typically, the means to trap catalyst particles will allow relatively easy passage of gases whereas catalyst particles, and/or fines thereof, and any liquid droplets entrained with such gases are trapped. Further, the means to trap catalyst particles will allow relatively easy removal of catalyst particles, and liquid droplets, by a liquid reflux.

The means to trap catalyst particles typically comprises one or more means which divert the passage of gases. Preferably, the gases are forced to follow a tortuous path. Thus, any catalyst particles collide with the means to divert the passage of gases. A liquid reflux is maintained to remove the said catalyst particles.

According to a preferred embodiment the means to trap catalyst particles, hereinafter also referred to as the trap, comprises one or more, in particular a plurality of, corrugated plates. Each corrugated plate contains at least one corrugation, preferably a plurality of corrugations. The corrugations define crests and troughs

- 11 -

on the corrugated plate. Typically, the corrugated plates are placed substantially vertical in the freeboard zone, and preferably substantially parallel to the overall direction of flow of the gases through the trap. The crests of the corrugations, however, are placed in such direction to the overall direction of flow of the gases through the trap, that the gases are forced to follow a tortuous path through the trap.

The degree of tortuosity may be defined as the ratio between the actual path length through the means to trap catalyst particles and a hypothetical shortest path length along a straight line. The said ratio is typically greater than 1:1, preferably at least 1.1:1, more preferably at least 1.2:1. Typically, the said ratio is not greater than 2:1, preferably not greater than 1.5:1.

The angle between the direction of the crests and the overall direction of flow of the gases through the trap is typically at least 30°, preferably at least 60°, more preferably substantially 90°.

The flow of gases in the freeboard zone is normally substantially vertical. According to one preferred embodiment, the means to trap catalyst particles is arranged such that the overall direction of flow of gases through the trap is substantially vertical as well. This allows a relatively simple construction. It will however be appreciated that a disadvantage of a substantially vertical (upward) flow of gases through the trap is that removal of catalyst with a substantially vertical (downward) liquid reflux may be difficult at relatively high gas velocities.

Therefore, alternatively, the trap is arranged such that the direction of flow of gases through the trap makes an angle of less than 180°, but more than 0°, with

- 12 -

the direction of flow of the liquid reflux. Preferably the angle ranges from 30° to 150°, in particular the angle is substantially 90°.

Thus, according to another preferred embodiment, the direction of flow of gas through the means to trap catalyst particles is substantially horizontal, and the liquid reflux is substantial vertical. As will be set out in more detail hereinafter, in particular in this embodiment it is preferred to transport catalyst to the slurry zone or to a rejuvenation zone inside or outside the reactor vessel, by means of a tube which does not allow entrance of gases in the freeboard zone.

The liquid reflux over the means to trap catalyst particles may be generated and maintained in the same way as described above. Preferably, the trap is cooled to generate a reflux of condensed gaseous product. Typically, the trap comprises cooling means. Thus, corrugated plates may be connected with one or more cooling tubes. Alternatively, the liquid reflux over the trap is maintained by spraying liquid from an external source over the trap.

The corrugations on the corrugated plates may be shaped in a large number of ways. Thus, for example, the corrugations may have the shape of a sine wave, a sawtooth wave, a triangular wave, a half- or full-wave rectified sine wave or combinations thereof. The corrugations preferably do not have the shape of a square wave.

For ease of manufacture, preferably, the shape of the corrugations is substantially constant across a corrugated plate, and the corrugated plates preferably have substantially the same size and shape.

- 13 -

Typically, the corrugated plates are arranged substantially in parallel. The space between the plates defines the passage for the gases. Preferably, the corrugated plates are arranged such that the width of the passage remains substantially constant.

The space between two corrugated plates is preferably in the range from 1 to 10 mm, more preferably from 2 to 5 mm.

The pressure drop between gas inlet and gas outlet of the trap is typically less than 2 bar, preferably less than 0.1 bar. Generally, the pressure drop will be more than 0.01 bar.

According to a further aspect, the present invention relates to a three phase slurry reactor for carrying out exothermic reactions in the presence of a catalyst, comprising reactant inlet means and product outlet means, a slurry zone equipped with slurry cooling means, and a freeboard zone, wherein the reactor is adapted to maintain a liquid reflux in the freeboard zone.

Typically, the three-phase slurry reactor is specifically adapted to the process of the present invention. Thus, it will be understood by those skilled in the art that preferred embodiments discussed in relation to the process are also preferred embodiments with respect to the three-phase slurry reactor.

Without wishing to be restricted to a particular embodiment, the invention will now be set out in more detail with reference to Figure 1 to 4.

Figure 1 schematically depicts a vertical cross-section through a three-phase slurry reactor 1 comprising a freeboard zone 5, which zone comprises a trap for catalyst particles 10, wherein the flow of gases through

the trap is substantially horizontal and the liquid reflux is substantially vertical.

Figure 2 schematically depicts a horizontal cross-section through the three-phase slurry reactor 1 along the line A-A', when looking in the direction of the arrow, as shown in Figure 1.

Figure 3 schematically depicts in more detail than in Figure 1 the part of the three-phase slurry reactor 1 containing the trap for catalyst particles 10. In particular, Figure 3 schematically depicts a vertical cross-section along the line B-B' as shown in Figure 2.

Figure 4 schematically depicts a corrugated plate of a trap for catalyst particles.

In more detail, Figure 1 depicts a three-phase slurry reactor 1, comprising a reactor wall 2 enclosing a slurry zone 3 and a freeboard zone 5. A sheet 6 defines the bottom end of the slurry zone 3. Dashed line 7 depicts the interface between the slurry zone 3 and the freeboard zone 5.

The reactor 1 is equipped with gas inlet means 60 and gas outlet means 70, slurry inlet means 80 and slurry outlet means 90. Sheet 6 allows passage of gas from gas inlet means 60 to the slurry zone 3.

The slurry zone 3 is equipped with cooling tubes (not shown), which cooling tubes do not extend into the freeboard zone 5.

The freeboard zone 5 is equipped with means to trap catalyst particles (trap) 10. The trap 10 contains a plurality of substantially vertical corrugated plates. The corrugated plates are arranged substantially parallel to each other, and substantially parallel to the overall direction of flow of gasses through trap 10. The corrugated plates may be contained in a circular housing,

- 15 -

but typically, the corrugated plates are contained in two or more, preferably four or six, discrete rectangular housings, as depicted in Figure 2.

Sheet 11 forces gases to flow substantially  
5 horizontal through the trap 10. Sheet 11 and trap 10 are cooled by cooling tubes as shown in Figures 2 and 3. In operation, catalyst particles are removed from sheet 11 and trap 10 by a liquid reflux.

10 Catalyst particles removed from trap 10 by a liquid reflux, are returned to the slurry zone 3 by tube 12. The outlet of tube 12 is immersed in the slurry zone 3.

Turning now to Figure 2, reference number 2 depicts the reactor wall of a three-phase slurry reactor 1. Six traps for catalyst particles 10 have been mounted on  
15 sheet 11. Each trap 10 contains a gas inlet 13 and a gas outlet 14. Gas outlet 14 is in fluid communication with hole 15 in sheet 11. Gas entering trap 10 is forced to follow a tortuous path along a plurality of corrugated plates 16. To generate a liquid reflux, corrugated  
20 plates 16 are cooled by means of cooling tubes 20. Cooling tubes 20 connect to a header (not shown) in the zone above sheet 11 (see Figure 3), and, preferably, is independent from the cooling system in the slurry zone 3.

Turning now to Figure 3, reference numbers which  
25 correspond to reference numbers in Figure 1 and/or 2 have the same meaning. Thus, Figure 3 depicts a trap for catalyst particles 10. Catalyst particles removed from trap 10 by a liquid reflux, are returned to the slurry zone 3 by tube 12. Due to the pressure drop over the  
30 trap 10 between gas inlet 13 and gas outlet 14, the interface level between slurry zone 3 and freeboard zone 5 in tube 12 will be somewhat higher than the level in the reactor, as indicated by dashed line 7.

- 16 -

To generate a liquid reflux, corrugated plates 16 (as shown in Figure 2) are cooled by means of cooling tubes 20. The cooling tubes are typically U-shaped. One end of the cooling tube 20 connects in fluid communication to coolant inlet tube 25, whereas the other end of cooling tube 20 connects in fluid communication to coolant outlet tube 30.

Coolant inlet tube 25 connects in fluid communication to coolant inlet distribution ring 35, and coolant outlet tube 30 connects in fluid communication to coolant outlet distribution ring 40. Distribution ring 35 connects in fluid communication to inlet means for introducing coolant into the reactor (not shown) and distribution ring 40 connects in fluid communication to outlet means for removing coolant from the reactor (not shown).

Suitable coolants are known to those skilled in the art. A preferred coolant is water and/or steam.

Figure 4 schematically depicts a corrugated plate 50 for use in a trap for catalyst particles 10 as shown in Figures 1 to 3. The plurality of corrugations on corrugated plate 50 define troughs 51 and crests 52.

The arrow in Figure 4 indicates the overall direction of flow of gases through trap 10. The corrugated plate 50 is placed substantially parallel to the overall direction of flow of gases through the trap, whereas the crests are placed substantially perpendicular to that flow. It will be appreciated that the crests of a plurality of stacked corrugated plates 50 force the gases to follow a tortuous path through the trap.

## CLAIMS:

1. A process for carrying out an exothermic reaction in the presence of solid catalyst particles in a three-phase slurry reactor comprising a slurry zone and a freeboard zone, in which slurry zone the catalyst particles are kept in suspension in a slurry liquid, which freeboard zone contains catalyst particles escaped from the slurry zone, and in which freeboard zone a liquid reflux is maintained to remove the catalyst particles from the freeboard zone.
2. A process as claimed in claim 1, wherein the catalyst particles present in the freeboard zone are recycled to the slurry zone.
3. A process for carrying out an exothermic reaction as claimed in claim 1 or 2, which exothermic reaction produces at least some gaseous products, which gaseous products are capable of at least partly condensing at a temperature between the reaction temperature in the top part of the slurry zone and 50°C below the said reaction temperature, wherein the gaseous products are at least partly condensed in the freeboard zone to generate the liquid reflux.
4. A process as claimed in claim 3, wherein the gaseous products are at least partly condensed by external cooling of the wall surrounding the freeboard zone, or wherein the gaseous products are at least partly condensed by allowing leakage of heat from the freeboard zone of the reactor, such that the temperature in the freeboard zone is decreased relative to the temperature in the top of the slurry zone, or wherein the gaseous products are at least partly condensed by cooling means in the freeboard zone.

- 18 -

5. A process as claimed in any one of claims 1 to 4, wherein the exothermic reaction is a Fischer-Tropsch synthesis reaction.
6. A process as claimed in any one of claims 1 to 5, wherein the freeboard zone contains means to trap catalyst particles, or wherein the freeboard zone contains means to trap catalyst particles comprising one or more corrugated plates and the liquid reflux is maintained over the corrugated plates.
7. A process as claimed in any one claims 1 to 6, wherein indirect slurry cooling means used to cool the slurry zone substantially does not extend into the freeboard zone.
8. A three-phase slurry reactor for carrying out exothermic reactions in the presence of a catalyst, comprising reactant inlet means and product outlet means, a slurry zone equipped with cooling means, and a freeboard zone, wherein the reactor is adapted to maintain a liquid reflux in the freeboard zone.
9. A three-phase slurry reactor as claimed in claim 8, wherein the freeboard zone contains means to trap catalyst particles.
10. A three-phase slurry reactor as claimed in claim 9, wherein the means to trap catalyst particles comprises a plurality of corrugated plates containing a plurality of corrugations, which corrugated plates are arranged substantially vertical and substantially parallel to the overall direction of flow of the gases through the means to trap catalyst particles, and wherein crests of the corrugations force gaseous products to follow a tortuous path through the means to trap catalyst particles.

- 19 -

11. A three-phase slurry reactor as claimed in claim 9, wherein the means to trap catalyst particles comprises a plurality of corrugated plates containing a plurality of corrugations, which corrugated plates are arranged substantially vertical and substantially parallel to the overall direction of flow of the gases through the means to trap catalyst particles, and wherein crests of the corrugations are placed in such direction to the overall direction of flow of the gases through the means to trap catalyst particles, that gaseous products are forced to follow a tortuous path through the means to trap catalyst particles.

12. A three-phase slurry reactor for carrying out exothermic reactions in the presence of a catalyst in the form of catalyst particles, comprising a reactor wall enclosing a slurry zone adjacent to a freeboard zone, a reactant inlet means allowing reactant to enter the reactor before the slurry zone, and a product outlet means allowing product to exit the reactor after the freeboard zone; wherein said slurry zone is equipped with a slurry zone cooling means; wherein said freeboard zone contains means to trap catalyst particles, said means to trap catalyst particles comprising one or more corrugated plates, and a means to maintain a liquid reflux in a said freeboard zone, said means to maintain a liquid reflux comprising a cooling means to cool said means to trap catalyst particles, said liquid reflux having a characteristic of removing the trapped catalyst particles from said freeboard zone.

13. A three-phase slurry reactor as claimed in claim 12, wherein said one or more corrugated plates each contain a plurality of corrugations each having a crest, which corrugated plates are arranged substantially vertical and

- 20 -

substantially parallel to an overall direction of flow of gases through the one or more corrugated plates, and wherein during operation the crests of the corrugations force the gases to follow a tortuous path through the one or more corrugated plates.

1/3

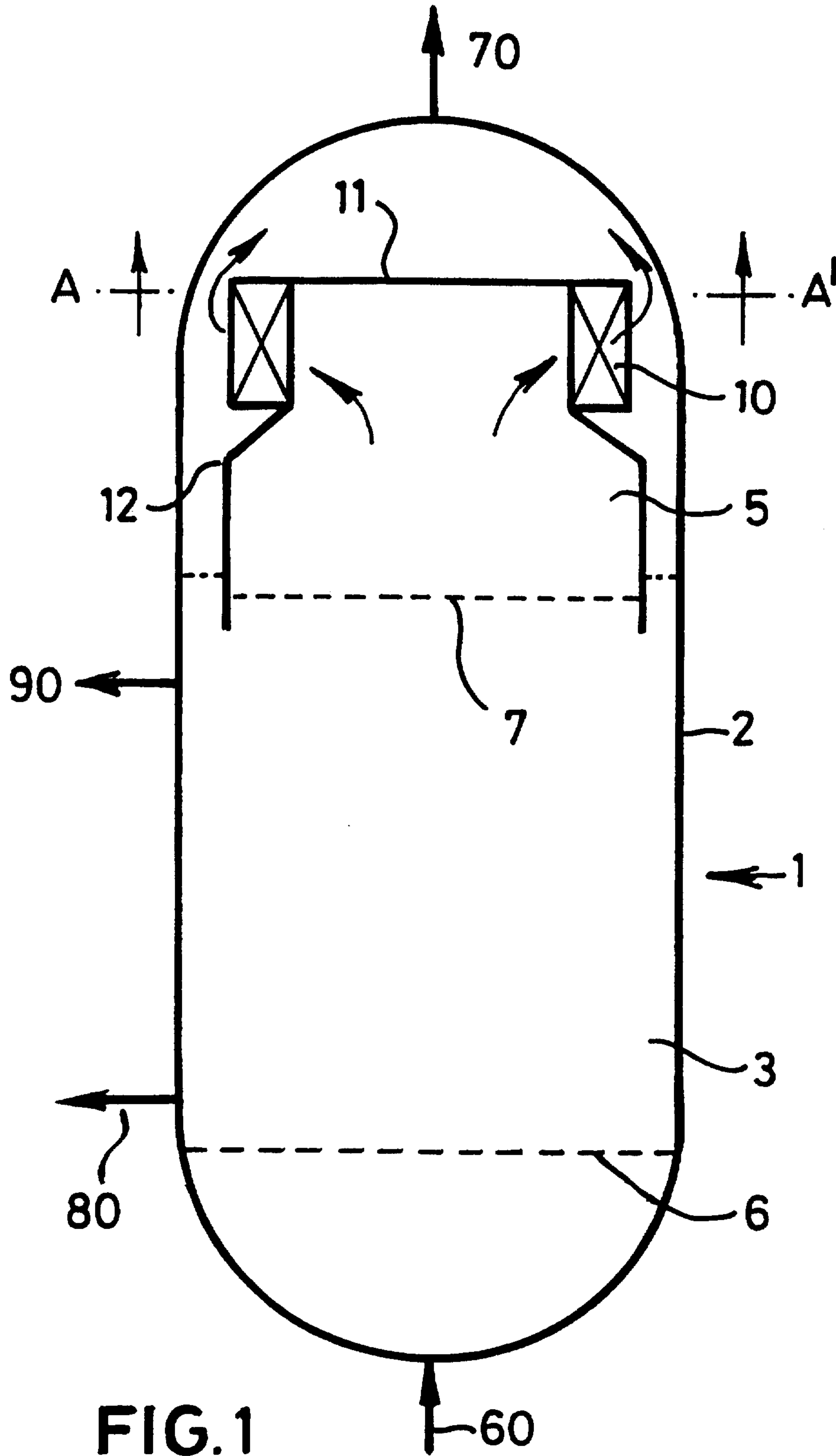

2/3

FIG. 2

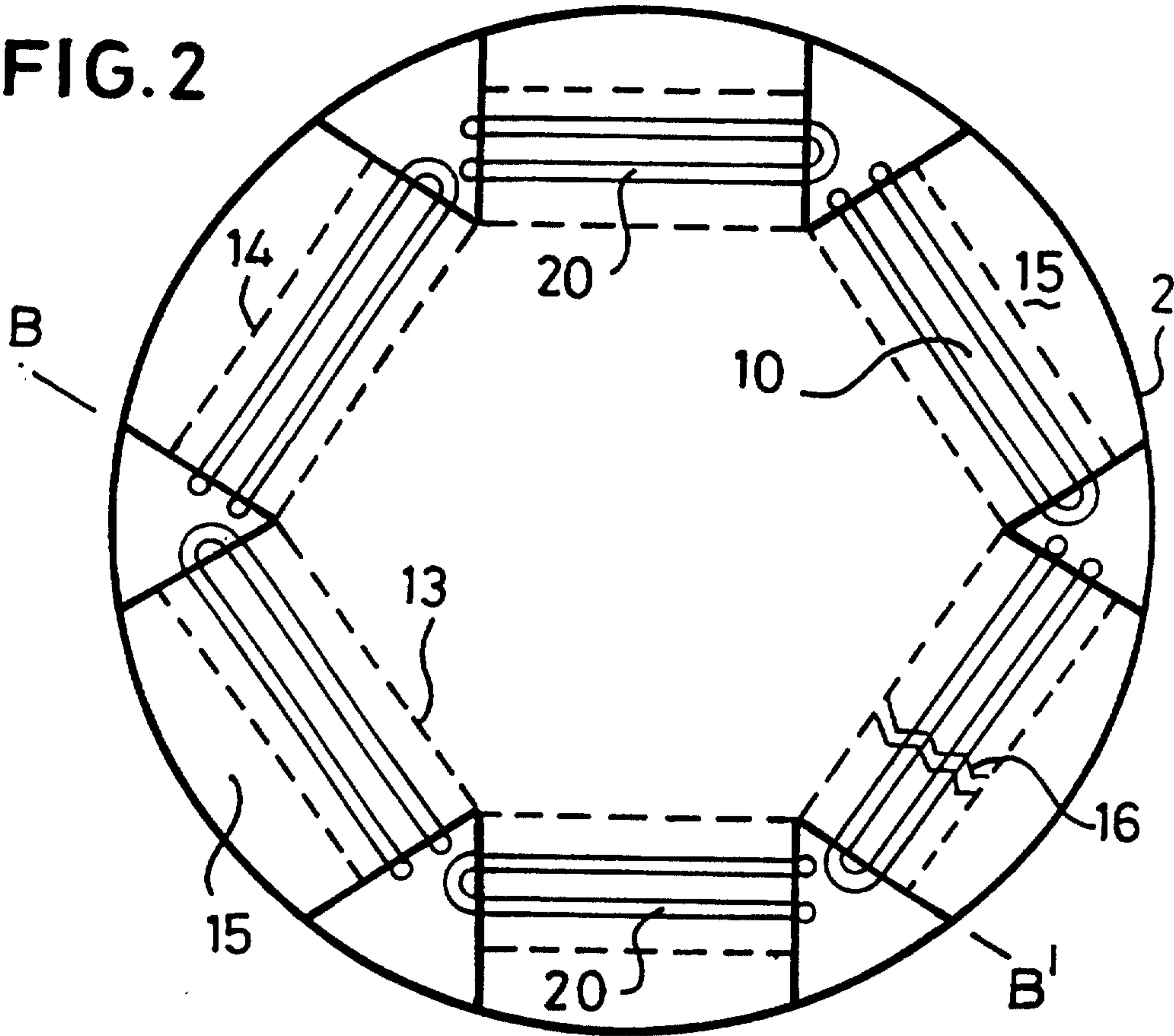
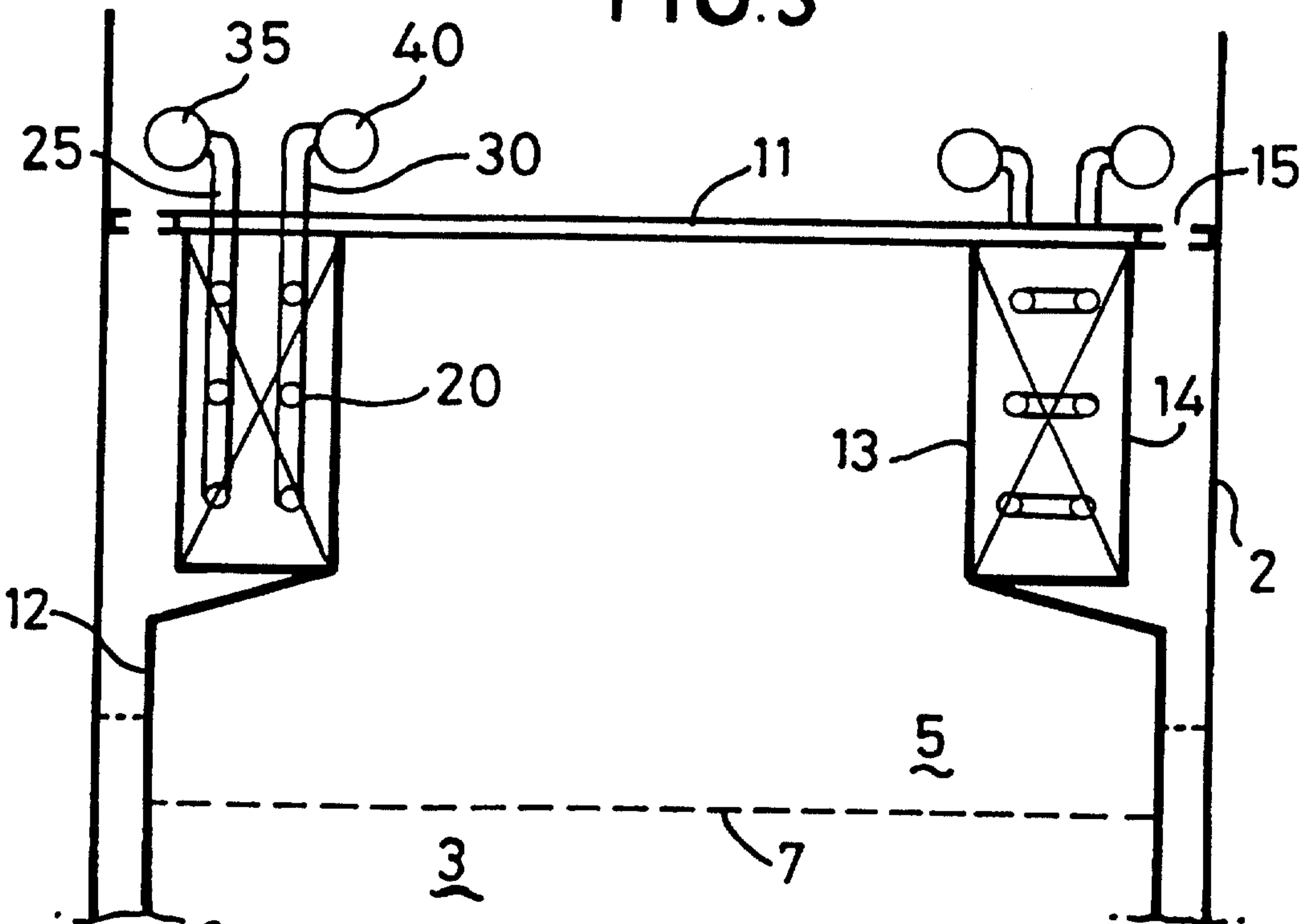

FIG. 3



3/3

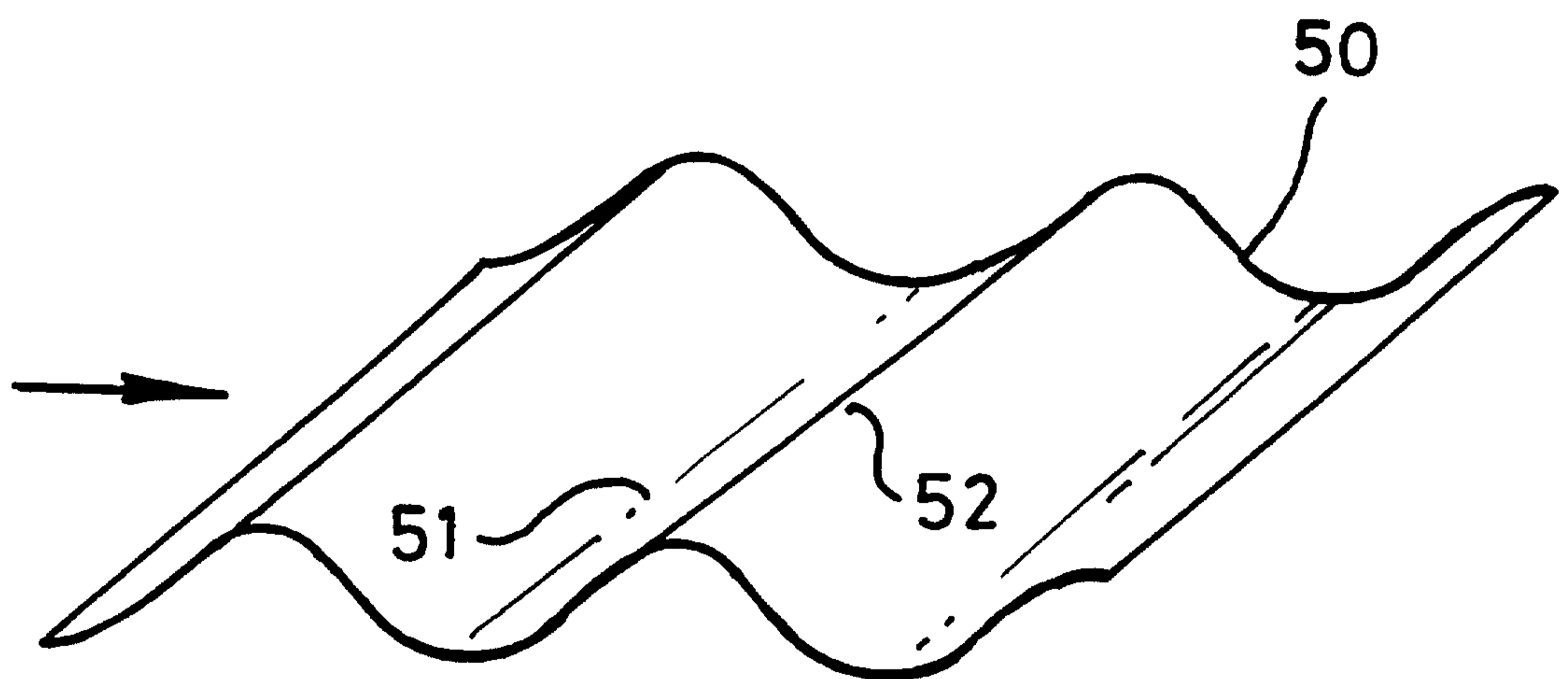

FIG.4

