

Nov. 9, 1965

H. SCHNÄCKEL

3,216,352

STAMPS

Filed April 27, 1961

3 Sheets-Sheet 1

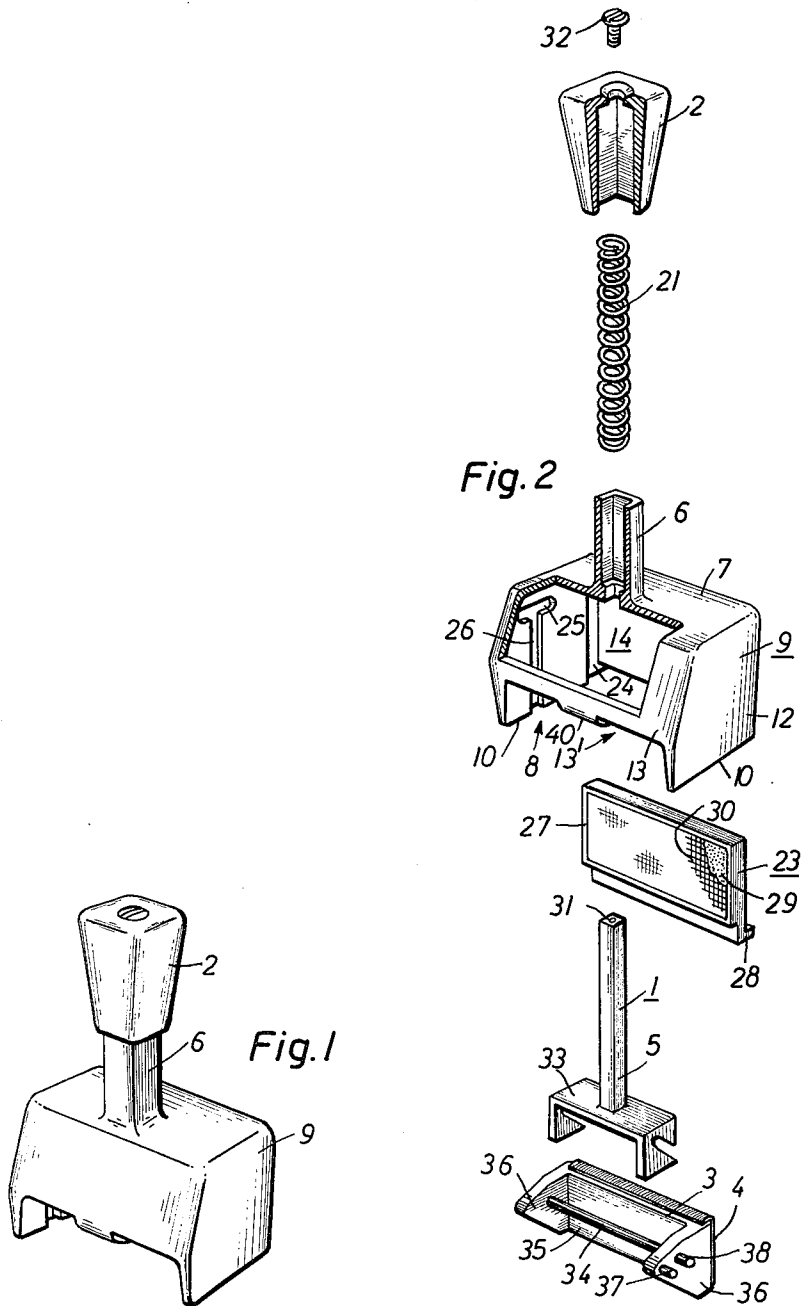

INVENTOR
H. Schnäckel
BY
Glasgow Downing Bechtel
ATTYS.

Nov. 9, 1965

H. SCHNÄCKEL

3,216,352

STAMPS

Filed April 27, 1961

3 Sheets-Sheet 2

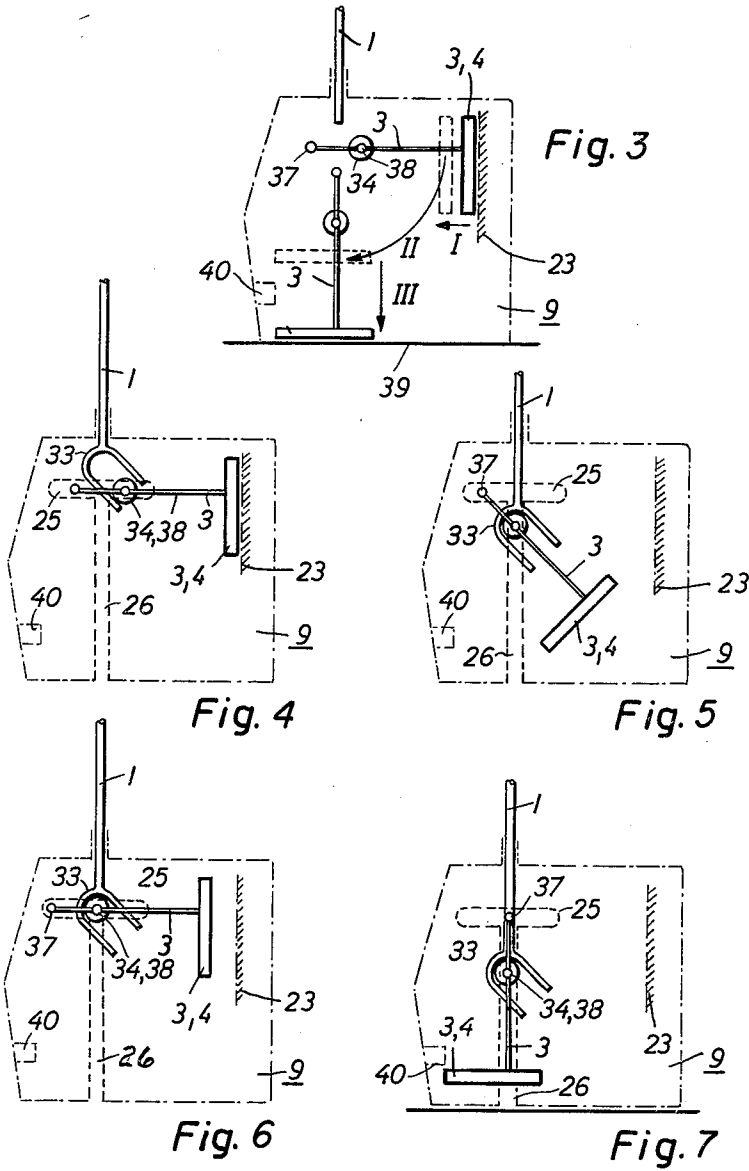

INVENTOR
H. Schnäckel
BY
Glascock Downing Keck
ATTYS

Nov. 9, 1965

H. SCHNÄCKEL

3,216,352

STAMPS

Filed April 27, 1961

3 Sheets-Sheet 3

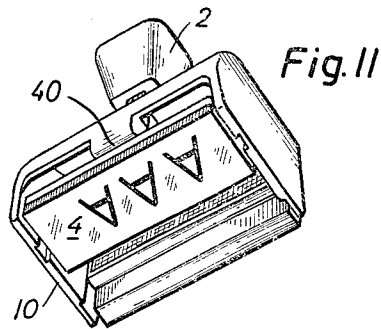
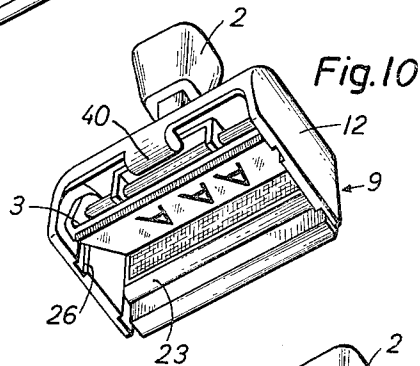
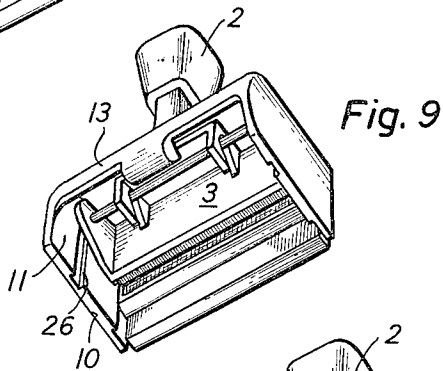
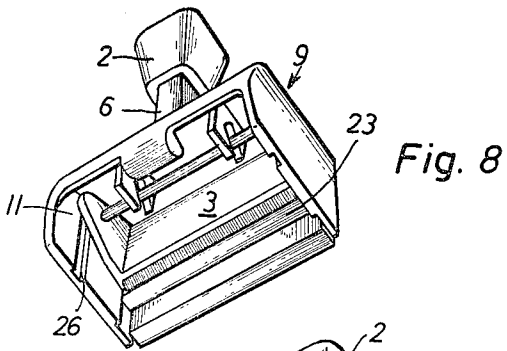

INVENTOR
H. Schnäckel
BY
Claswell Downing Peck
ATTYS

1

3,216,352
STAMPS

Hans Schnäckel, Lessingsstrasse, Weiden,
near Cologne, Germany

Filed Apr. 27, 1961, Ser. No. 106,127

Claims priority, application Germany, May 4, 1960,
Sch 27,847

6 Claims. (Cl. 101—333)

The invention relates to stamps which on the one hand have the known feature of a stamp dye reservoir co-operating with the printing plate and in novel combination therewith the feature, also known, of a printing plate which is resiliently upwardly pressed and normally concealed in a box, which is open below, but which can be downwardly pressed from out of the box. This combination is indeed not broadly new and does not constitute as such the object of the invention. The invention relates rather to an improvement of this combination.

For whatever form of construction related to the above described combination is considered, there is present the drawback that the stamp dye reservoir is free and unprotected, on account of which the stamp dye reservoir dries relatively quickly and easily causes soiling of hands, writing tables, portfolios, etc., which is disadvantageous.

The invention consists in first of all generally removing the mentioned drawbacks, this being particularly favourable for so-called self-inking stamps.

According to the invention this object is solved by also arranging the stamp reservoir within the box—which is sufficiently large for the purpose—of a stamp of the type described at the outset.

The invention can be applied in practice quite generally and prevents in the simplest way drying of the stamp dye reservoir as well as soiling by the stamp dye reservoir. This is also true in the case of the so-called self-inking stamps. The use of the above-described inventive idea in the case of self-inking stamps however leads to—in addition to the desired advantages—the drawback of a construction which is unwieldy as a whole in consequence of the large height and of the plunger being divided in forked manner.

According to the invention it is therefore proposed for self-inking stamps to arrange the stamp pad on the rear wall of the box and to guide the plunger by a single central plunger guide through the cover of the box. In this way the height is arranged to be substantially smaller and the bulky forked type of plunger is eliminated. The printing plate is, exactly or approximately, horizontally withdrawn from the stamp pad so that it no longer has to be downwardly pivoted through 180° but only through 90°. In this way the length stroke of the plunger is reduced and also the turning gearing is simplified, so that a very simple uncomplicated and practical self-inking stamp is obtained which has all the above-mentioned advantages in consequence of the box provided according to the invention. According to the invention the box forms the stamp frame, which contains the gear elements arranged stationary on the frame. It is further proposed to form all these gear elements arranged stationary on the stamp frame as guide grooves or guide strips—thus reducing the number of movable gear parts—so that there is obtained a self-inking stamp constructed of only a few parts and which preferably can be manufactured, with the exception of a few strongly stressed parts e.g. springs or the like, from synthetic material. In this way the invention permits the production of a self-inking stamp which, with respect to known forms of construction, is advantageous in many respects and at the same time is very cheap.

2

Embodiments of the invention are hereafter described with reference to the accompanying drawings wherein:

FIGURE 1 is an elevational view of a particularly advantageous embodiment according to the invention of a new type of self-inking stamp,

FIGURE 2 is an exploded view of the self-inking stamp according to FIGURE 1,

FIGURE 3 shows diagrammatically the necessary course of movement for the self-inking stamp of FIGURE 1,

FIGURE 4 shows diagrammatically and in the rest position the control or gear arrangement for the self-inking stamp shown in FIGURE 1,

FIGURE 5 is a diagrammatic view of the control or gear arrangement of FIGURE 4, with the printing plate drawn back in horizontal direction,

FIGURE 6 shows the gear arrangement of FIGURE 4 during the pivoting movement of the printing plate,

FIGURE 7 shows the gearing arrangement of FIGURE 4 during the vertical downwards movement of the printing plate,

FIGURE 8 shows the self-inking stamp of FIGURE 1, viewed obliquely from below and with the position of the gearing as shown in FIGURE 4,

FIGURE 9 is a similar view to that of FIGURE 8 but with the gearing in the position of FIGURE 5,

FIGURE 10 is a similar view but with the gearing in the position of FIGURE 6, and

FIGURE 11 is a similar view to that of FIGURE 8 but with the control or gear arrangement in the position of FIGURE 7.

In all the figures the plunger is provided above with a knob 2 and is connected in its lower part with a printing plate holder 3, on the lower end of which is stuck the printing plate 4.

The plunger 1 is vertically displaceable and is guided by its central part within the plunger guide 6 located in the cover 7 of a box 9 which is open in its lower part 8. The lower ends 10 of side walls 11, 12 and possibly of front and rear walls 13, 14 of box 9—which ends lie in a single plane of the stand—form a stand by means of which the stamp may be placed on a supporting surface e.g. a writing table. At the same time the vertical movement of plunger 1 may be limited by stops. When the plunger 1 is in its upper position (see for example FIGURES 3 and 4) the printing plate 4 is located above the plane of the stand and within the box 9, and when the plunger 1 is in its lower position (see for example FIGURE 11) the printing plate is in the printing position i.e. in the plane of the stand or below that plane in the plane of edges 10. As long as the stamp is not in use its printing plate 4 will thus always be within the box 9. On the one hand the box 9 protects the printing plate 4 from outside influences and on the other hand it protects persons or outwardly located objects from the inked printing plate 4. In addition, the box 9 forms a stand for the stamp and serves the purpose of a protective packing in the case of transportation.

The box 9 may consist of transparent material (e.g. transparent polystyrene or the like) or of opaque material (e.g. metal, opaque polyamide or the like). In the case of the embodiment of FIGURES 1 to 11 the front 13 of box 9 is open in its lower part, thus forming a window 13' which facilitates setting down the stamp on the correct place, of the supporting surface or of the document to be stamped.

The self-inking stamp consists only of seven separate parts: knob 2, spring 22, plunger 1, printing plate holder 3 with printing plate 4 stuck thereon, box 9, pressure spring 21 and stamp pad 23.

The box 9 has a cover 7, side walls 11, 12, a front

wall 13 and a rear wall 14. The cover 7 contains the vertical plunger guide 6 in the form of a well with a lower supporting surface for the spring 21. The front wall 13 is open in its lower part and in this region forms a window 13' (FIG. 2) which facilitates correct setting down of the self-inking stamp on the material to be stamped. In the box 9 are provided, in front of the rear wall 14, grooves 24 for receiving the stamp pad 23. In both side walls 11, 12 there are horizontal grooves 25 and vertical grooves 26, which grooves meet to form a T-shape.

The stamp pad consists of a frame 27 which can be removably inserted into the grooves 24 of the box 9 and can be held in position there by frictional grip so that the stamp pad 23 stands vertically in front of the rear wall 14. On the lower edge is provided a gripping tongue 28 by which the stamp pad 23 can be withdrawn downwardly from the box 9. In the frame 27 is an absorbent layer 29 e.g. made of foam synthetic material, which is covered by a layer of fabric 30.

The plunger 1 has at its upper end a threaded bore 31 for the screw 32 and at its lower end a wedge guide 33 for the pin 34. The plunger 1 is mounted with its central part 5 vertically displaceable in the plunger guide 6 of the box 9. On the upper end of the plunger 1 is thrust the pressure spring 21 which, together with the plunger, is mounted within the plunger guide 6 and presses with its lower end on to the supporting surface formed in the manner of an inner flange. The knob 2 is arranged on the upper ends of plunger 1 and pressure spring 21 in the manner of a cap, and is held by the screw 32 which is screwed into the threaded bore 31. At the same time the knob 2 is mounted—again in the manner of a cap—over the plunger guide 6 which, when the knob 2 is depressed, penetrates into the knob 2, the pressure spring being compressed and the plunger 1 being moved vertically downwards.

The printing plate holder 3 consists of a plate 35 which extends vertically when in its rest position and which has two lugs 36 bent off at a right-angle. Both lugs have, arranged horizontally behind one another, a rear stud 37 and a front stud 38, the two front studs 38 being disposed co-axially with the pin 34. The distance between the rear studs 37 and the front studs 38 corresponds to the distance between the point at which a vertical groove 26 meets its associated horizontal groove 25 and the end of this horizontal groove remote from the stamp pad 23 (see FIGURE 5). The distance between the front stud 38 or the pin 34 and the plate 35 is such that there is still a certain distance between the front studs 38 and the points at which the vertical grooves 26 meet the horizontal grooves—and also between the rear studs 37 and the ends of these grooves 25 located remote from the stamp pad 23—when the printing plate holder 3, with the printing plate 4 stuck on the front side of its plate 35, is pressed in its rest position against the stamp pad 23 (see FIGURE 4). The printing plate holder 3 is so introduced into the box 9 that the studs 37, 38 can slide in the grooves 25, 26 and the pin 34 is continuously located in the wedge guide 33 on the plunger 1.

FIGURE 3 shows that three functions must be actuated successively by depression of the plunger 1: first of all the printing plate 4 is lifted horizontally from stamp pad 23 (arrow 1); then the printing plate 4 is pivoted downwards through 90° (arrow 11); then and lastly the printing plate 4 is pressed downwards on to the surface 39 which is to be stamped (arrow 111).

FIGURES 4 to 7 show diagrammatically the functioning of the stamp control or gearing system during the individual phases of movement; the FIGURES 8 to 11, shown in perspective, may also be referred to for clearer understanding.

FIGURES 4 and 8 show the stamp in the rest position, wherein the printing plate 4 is pressed against the stamp pad 23 and thus remains continuously covered with ink and at the same time is protectively shielded.

FIGURES 5 and 9 show (corresponding to arrow 1 in FIGURE 3) how, when the plunger 1 is depressed, first of all the pin 34—with the printing plate holder 3 guided on the studs 37, 38 in the horizontal grooves 25—is withdrawn in the horizontal direction by means of the wedge guide 33, until the front studs 38 are located over the vertical grooves 26.

FIGURES 6 and 10 show how—when the plunger 1 is further depressed—the pin 34 strikes on the end of the wedge guide 33 and, together with the front studs 38, is pressed vertically downwards into the vertical grooves 26, the rear studs 37 again moving forwards by a certain amount, so that a control or gear function is obtained as in the case of the known ellipse-cross circle, and the printing plate 4 (corresponding to arrow 11 in FIGURE 3) is pivoted downwards in an elliptical path and through an angle of 90°. This pivotal movement lasts until the front studs 38, which are now moving in the forward direction, are located above the vertical grooves 26.

FIGURE 7 illustrates this position. When the plunger 1 is depressed further, then all the studs 37, 38 slide downwards in the vertical grooves 26 (corresponding to arrow 111 in FIGURE 3) and guide the printing plate 4, now extending horizontally, vertically downwards until it reaches the position shown in FIGURE 11 wherein it is pressed on to the surface 39 to be stamped and effects the stamping action.

When pressure on knob 2 is relaxed, then the pressure spring 21 guides the self-colouring stamp back into its rest position, the control or gear functions taking place in the reverse sequence.

In order that the stamp, when returning from the position of FIGURE 11 into that of FIGURES 6 or 10, is not blocked in the intermediate position of FIGURE 7, a fixed guide lug 40 is arranged on the box 9 (see FIGURE 11), the printing plate holder 3 striking with its plate 35, on this lug during the return movement and shortly before the position shown in FIGURE 7 is reached. The guide lug 40 then so tilts the printing plate holder 3 about the pin 34 that the rear studs 37 move back in the horizontal grooves 25 and the positions shown in FIGURES 6, 5 and 4 are again reached. The guide lug 40 must not be disposed on the front wall 13. There can also be arranged, laterally on the inner sides of the side walls 11, 12, two guide lugs which cooperate with the lugs 36 of the printing plate holder 3. Finally timely tilting of the printing plate holder 3 may also be effected by a corresponding curved or bent formation of the upper sides of the horizontal grooves 25 which impart a movement component in the tilting direction to the rear studs 37.

When the stamp gearing is operating in the return direction, the printing plate 4 and the stamp pad 23 can cooperate to form upper limit stops. However if the stamp pad 23 is very soft there can also be used special fixed upper limit stops (not shown) which restrict the movement of the printing plate holder 3 with respect to the stamp pad 23.

With the exception of the pressure spring 21, the screw 32 and the rear stud 37—as well as the pin 34 forming an integral unit with the front stud 38—all parts of the self-inking stamp are advantageously made of synthetic material. Preferably an opaque, resilient but not too soft polyamide is used, such as is for example known by the trade mark "Nylon." The parts are then manufactured by a known extrusion process, the rear studs 37 and the pin 34 being already embedded in the mass of synthetic material in the extrusion mould. By reason of the fact that the box 9 at the same time forms the frame of the stamp and also that the stamp gearing—instead of comprising many movable gear parts—only has a few straight guides 25, 26 which are arranged stationary on the frame, it is possible to produce a self-inking stamp consisting of only a few parts and which can be made practically en-

tirely from synthetic material and in a stable, and at the same time cheap, form of construction.

Such a self-colouring stamp according to the invention is protected against dust and therefore will always supply clean stamp impressions. The stamp does not require a special stand. It does not dirty its surrounding area and can be transported without any special packing. Its stamp pad is practically incapable of drying by itself. The stamp is unbreakable, impervious to heat and—even with respect to its visible surfaces—is non-corrosive. The stamp is, further, considerably cheaper to manufacture than comparable known stamps. It is also smaller and more compact in construction and makes it possible to provide larger printing plates than hitherto in self-colouring stamps of smaller dimensions than hitherto. Because its gearing is very simple and uncomplicated, the stamp is less liable to damage than known forms of constructions.

The control or gearing system with the vertical arrangement of the stamp pad and the pivotal action of the printing plate through 90° only is a particularly favourable one for installation in the box provided according to the invention. For above all the control or gearing system makes it possible to keep the box small and compact. However, as substantial advantages of the gearing or control system remain even when the box is cut away or recessed to a greater or lesser extent—or is even constructed as an open frame—special protection is claimed for the control or gearing system even when according to the invention, there is no box provided.

I claim:

1. A self-inking hand stamp having a frame and an upwardly biased plunger, said frame including two downwardly extending end portions, inwardly facing opposed identical erect T-shaped slots in said downwardly extending end portions, an ink pad having its inking face lying in a vertical plane when the hand stamp is in use on a horizontal surface and positioned at the rear of said frame opposite one end of the arms of said T-shaped slots, a printing plate holder, a printing plate mounted in said printing plate holder, said printing plate and holder, when in printing position, being positioned at the bottom of the stem of said T-shaped slots and having said printing plate presented downwardly, two studs mounted above said printing plate holder at each end of said printing plate holder and rigidly secured thereto that lie, when said printing plate holder is in printing position, in the stems of said T-shaped slots, the upper of said studs being free to slide in said T-shaped slots, wedge guide means mounted within said frame on said upwardly biased plunger to move vertically therewith, said wedge guide

means being provided with a wedge slot lying at an angle to the stem of said T-shaped slot, the upper end of said wedge slot lying in the vertical plane of the stems of said T-shaped slots and extending downwardly and rearwardly therefrom, the lower of said studs of each said two studs being engaged in said wedge slot whereby, upon reciprocation of said biased plunger, said printing plate will be moved between a printing position when said plunger is fully depressed against said bias and a normal position with said printing plate against said ink pad.

2. The self-inking hand stamp of claim 1 in which a fixed element is mounted on said frame in a position to stop upward motion of the side of said plate holder remote from said ink pad when said upper of said studs is located at the cross of said T-shaped slots.

3. The self-inking hand stamp of claim 1 in which the length of the arms of said T-shaped slots is at least equal to a distance to include both of each said two studs.

4. A self-inking stamp device according to claim 1 wherein said ink pad is removably mounted in said frame.

5. A self-inking stamp device according to claim 1 wherein said plunger is provided with a single central plunger guide adjacent the top of said frame for guiding the movement of said plunger, and said frame is provided with a rear wall connected at its ends to said side walls and disposed laterally thereto, said ink stamp pad being mounted on said rear wall.

6. A self-inking stamp device according to claim 1 wherein said T-shaped slots in each of said end portions comprise a horizontal groove portion and a vertical groove portion communicating with one another, said slots extending in depth only partially into said walls and terminating short of the outer surfaces of said walls, said studs on said printing plate holder projecting into said slots, said studs being both disposed in said horizontal groove portions when said printing plate is in position against said ink pad and both disposed in said vertical groove portions when said plate is in stamping position.

References Cited by the Examiner

UNITED STATES PATENTS

1,024,389	4/12	Belknap	-----	101—334
2,312,727	3/43	Nisenson	-----	101—334
2,638,049	5/53	MacPhee et al.	-----	101—327
2,884,858	5/59	Boekeloo et al.	-----	101—327
2,900,902	8/59	Becker	-----	101—327 X

FOREIGN PATENTS

509,864	11/20	France.
---------	-------	---------

ROBERT E. PULFREY, *Primary Examiner.*