



US 20040187429A1

(19) **United States**

(12) **Patent Application Publication**

(10) **Pub. No.: US 2004/0187429 A1**

Gross

(43) **Pub. Date:**

Sep. 30, 2004

(54) **DRAG REDUCING ROTATABLE FAIRING
USABLE ON POLES, POSTS AND OTHER
STRUCTURES**

Publication Classification

(76) **Inventor:** William Gross, Pasadena, CA (US)

(51) **Int. Cl.⁷** **E04H 9/14**

(52) **U.S. Cl.** **52/720.1; 52/169.9**

Correspondence Address:

**KNOBBE MARTENS OLSON & BEAR LLP
2040 MAIN STREET
FOURTEENTH FLOOR
IRVINE, CA 92614 (US)**

(57) **ABSTRACT**

(21) **Appl. No.:** 10/810,752

(22) **Filed:** Mar. 26, 2004

In one aspect of the invention, a rotatable fairing apparatus comprises a vertical support member anchored in a foundation and subjected to an aerodynamic drag force. The rotatable fairing apparatus further comprises a hollow elongate fairing sleeve that covers at least a portion of the vertical support member. The hollow elongate fairing sleeve is rotatably secured to the vertical support member. Additionally, the hollow elongate sleeve has a shape configured to reduce the aerodynamic drag force acting on the vertical support member.

Related U.S. Application Data

(60) Provisional application No. 60/459,009, filed on Mar. 28, 2003.

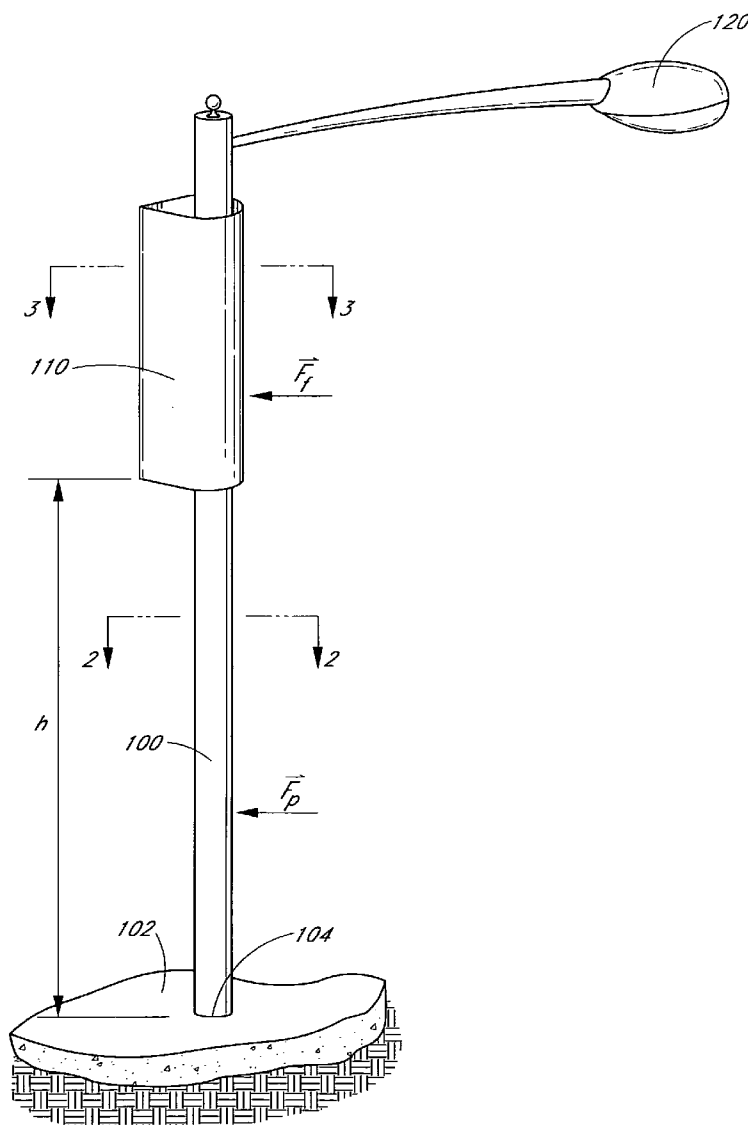

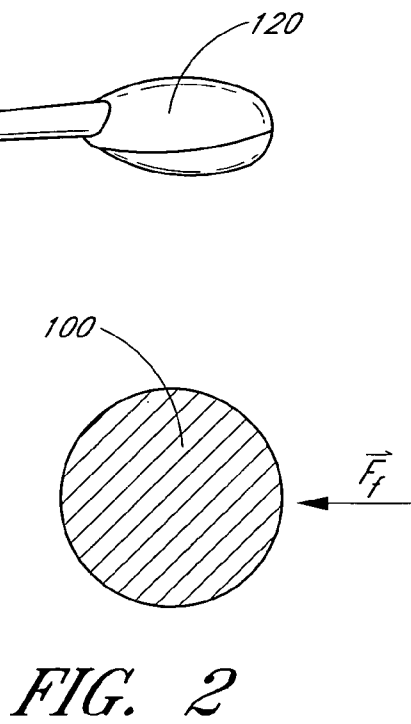
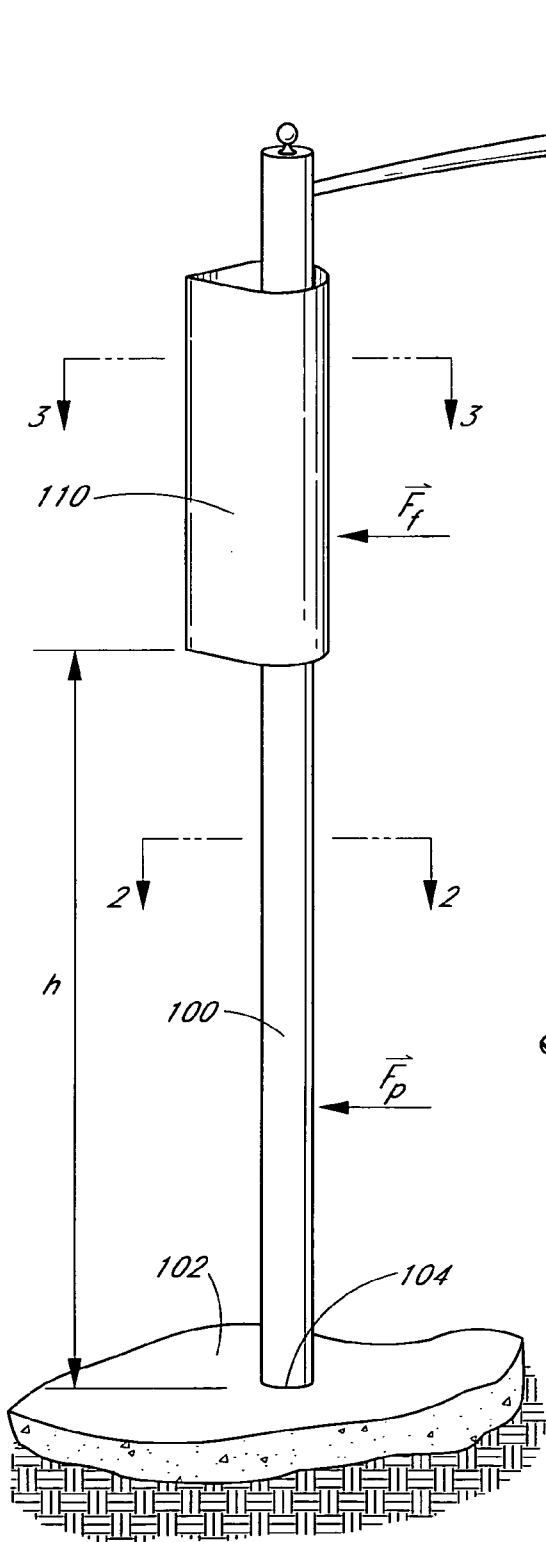

FIG. 2

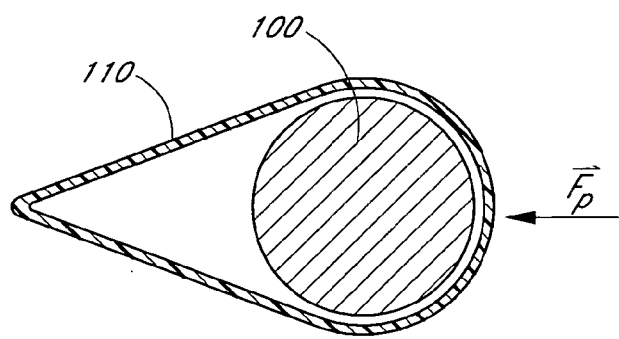
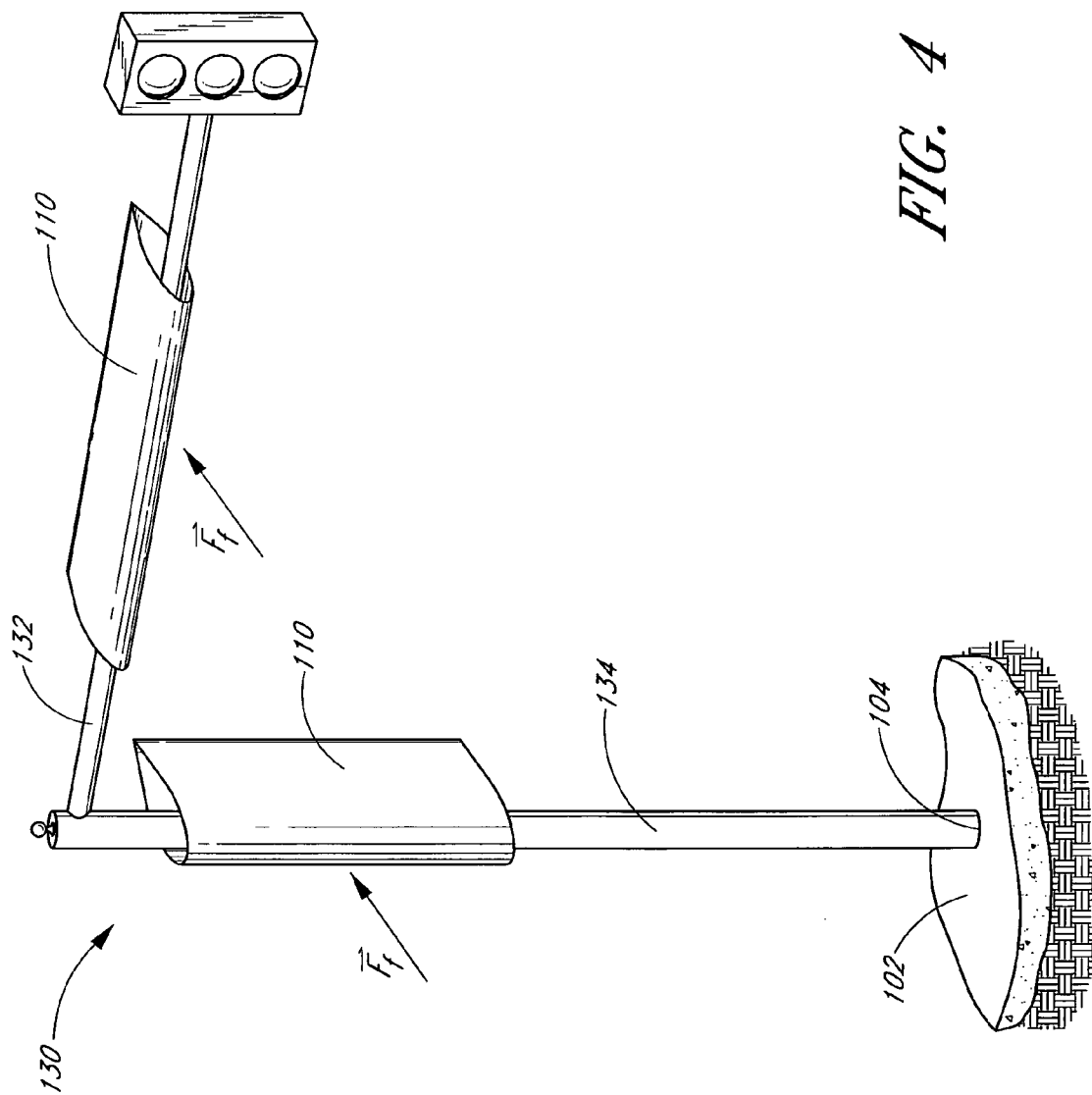

FIG. 3

FIG. 1



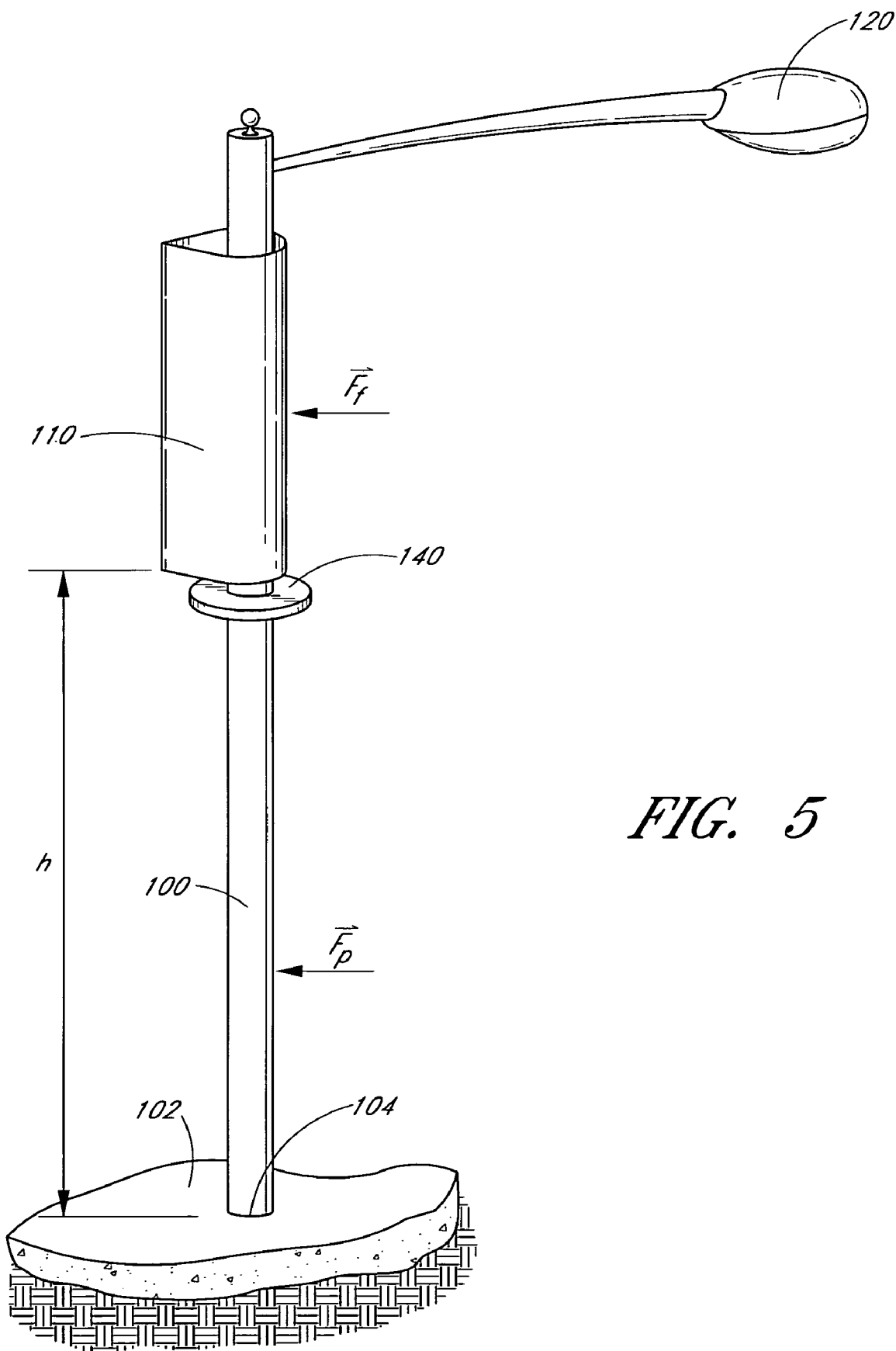

FIG. 5

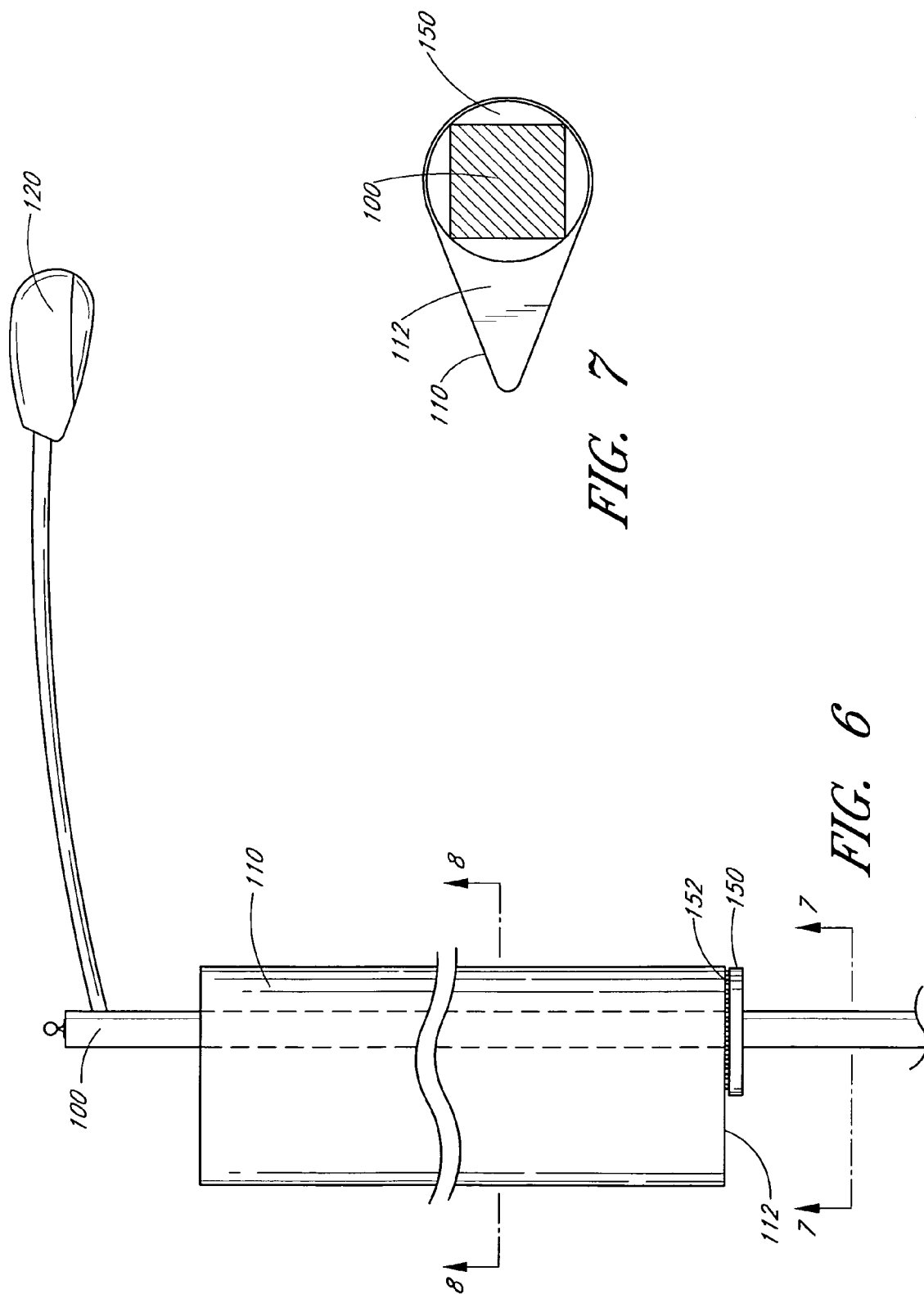

FIG. 7

FIG. 6

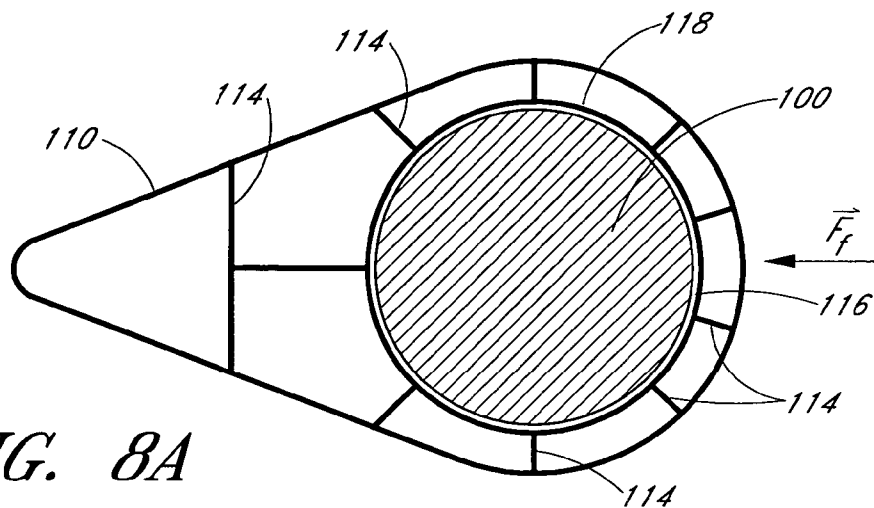

FIG. 8A

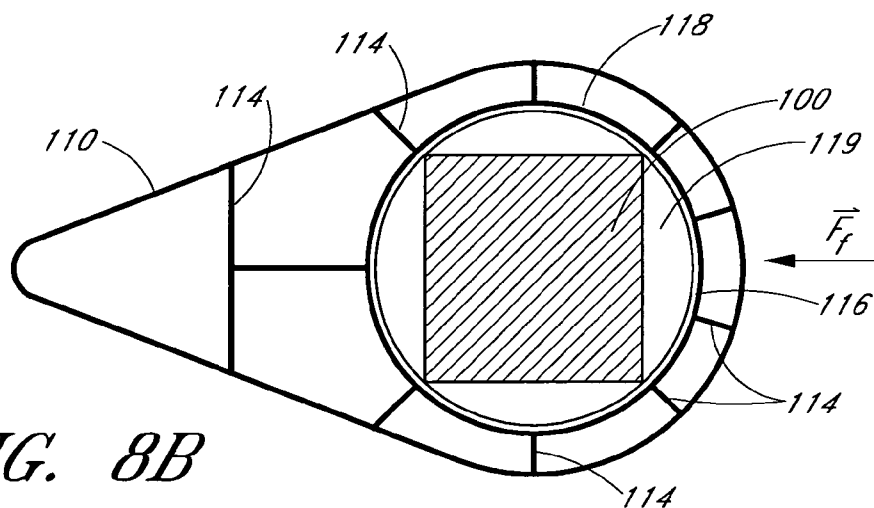

FIG. 8B

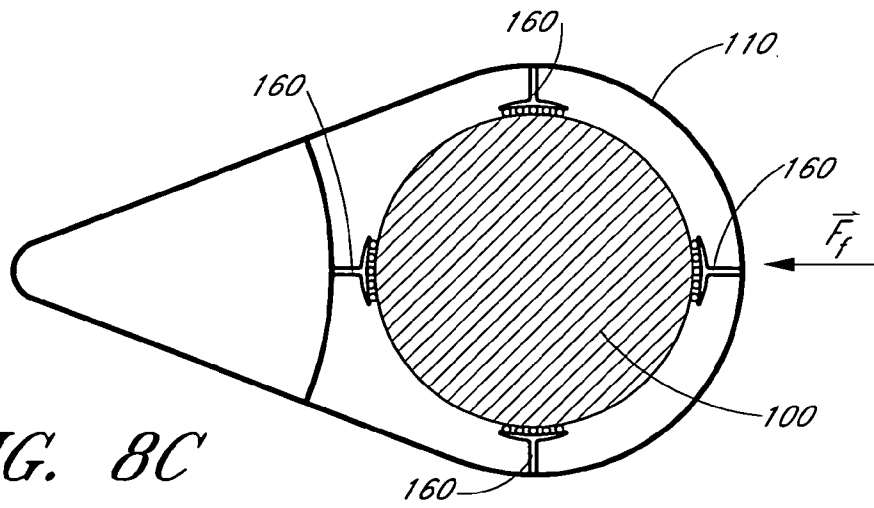

FIG. 8C

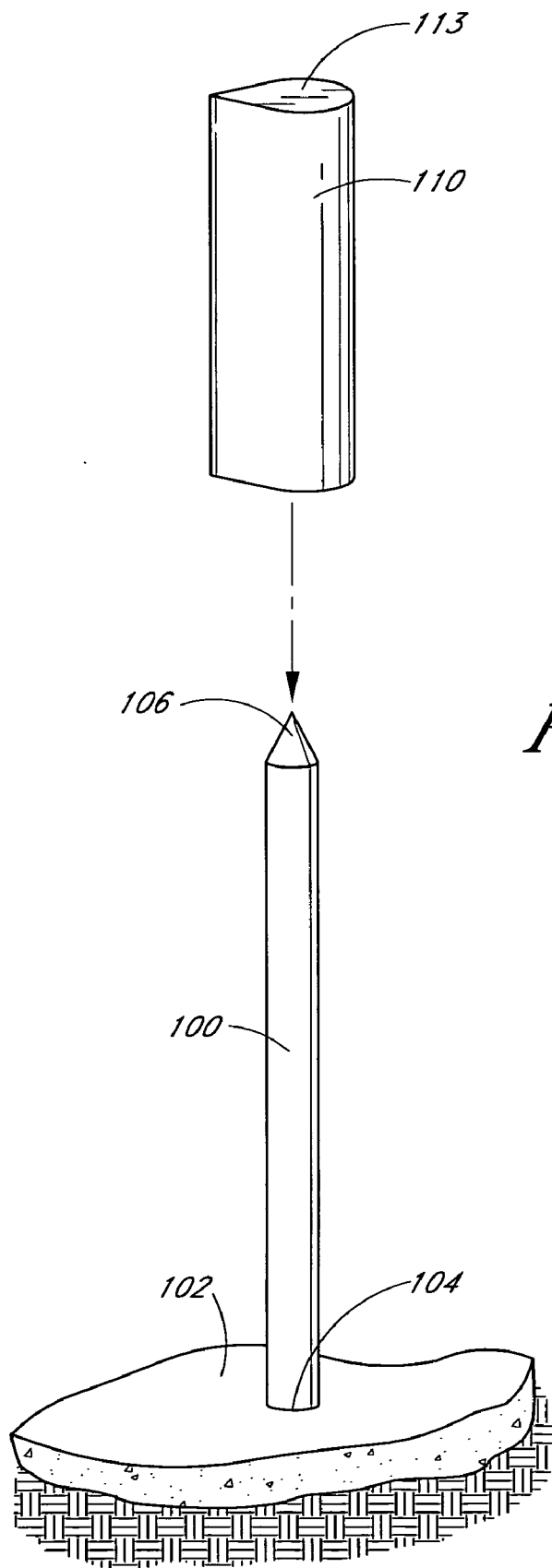

FIG. 9

**DRAG REDUCING ROTATABLE FAIRING
USABLE ON POLES, POSTS AND OTHER
STRUCTURES**

PRIORITY APPLICATION

[0001] This application claims the benefit of U.S. Provisional Patent Application No. 60/459,009, filed 28 Mar. 2003, the entire disclosure of which is hereby incorporated by reference herein.

BACKGROUND OF THE INVENTION

[0002] 1. Field of the Invention

[0003] The present invention relates generally to a rotatable fairing configured to reduce aerodynamic drag forces on a stationary object.

[0004] 2. Description of the Related Art

[0005] Objects placed in outdoor environments are often subjected to a wide variety of adverse meteorological conditions, such as extreme temperatures, heavy precipitation, and strong winds. Although all of these conditions can be harmful, strong winds can be especially damaging. In particular, not only can strong winds directly damage an exposed object, such as by toppling or breaking the object, but an object that has toppled or that has become airborne can create a significant safety hazard. Therefore, while winds can unquestionably damage large outdoor objects (for example, skyscrapers or automobiles), smaller outdoor objects such as poles, road signs, and raised light fixtures can be particularly dangerous during a windstorm. Specifically, such smaller outdoor objects not only can be directly damaged by the wind, but can also inflict damage upon other people or objects if they topple or become airborne.

[0006] Therefore, to minimize recurring maintenance costs and to reduce the dangers associated with toppling or airborne debris during windstorms, smaller outdoor objects such as poles, road signs and raised light fixtures are generally designed to withstand strong winds. However, conventional designs have necessitated the use of heavy sidewalls and strong foundations to achieve strong wind resistance. Heavy sidewalls and strong foundations are expensive to construct, and can cause increased damage in the event of structural failure.

SUMMARY OF THE INVENTION

[0007] Thus, it is desired to develop outdoor objects such as poles, road signs and raised light fixtures that can withstand strong winds without necessitating the use of heavy sidewalls and strong foundations. Certain embodiments of the present invention address these desires, advantageously allowing the weight and expense of outdoor objects such as poles, road signs and raised light fixtures to be reduced without sacrificing ability to withstand strong winds. Specifically, placement of a rotatable fairing on at least a portion of the pole, road sign or raised light fixture reduces the aerodynamic drag force acting thereon, thereby making the object able to withstand stronger winds.

[0008] In one aspect of the invention, a rotatable fairing apparatus comprises a vertical support member anchored in a foundation and subjected to an aerodynamic drag force. The rotatable fairing apparatus further comprises a hollow

elongate fairing sleeve that covers at least a portion of the vertical support member. The hollow elongate fairing sleeve is rotatably secured to the vertical support member. Additionally, the hollow elongate sleeve has a shape configured to reduce the aerodynamic drag force acting on the vertical support member.

[0009] In another aspect of the invention, an apparatus comprises an elongate support member and an elongate fairing sleeve. The elongate fairing sleeve has a first axis, and covers at least a portion of the elongate support member. Additionally, the elongate fairing sleeve is configured to rotate around the elongate support member on the elongate fairing sleeve first axis. The elongate fairing sleeve is also substantially shaped to reduce an aerodynamic drag force acting on the elongate support member.

[0010] In yet another aspect of the invention, an apparatus comprises an elongate support member and an elongate fairing sleeve. The elongate fairing sleeve has a longitudinal axis, and covers at least a portion of the elongate support member. The apparatus further comprises means for attaching the elongate support structure to the elongate fairing device, such that the elongate fairing device can rotate around the elongate support member on the elongate fairing sleeve longitudinal axis.

[0011] In yet another aspect of the invention, an apparatus comprises first and second elongate support members and first and second elongate fairing sleeves. The first elongate support member is attached to the second elongate support member. The first elongate fairing sleeve covers at least a portion of the first elongate support member, and is configured to rotate around the first elongate support member. Likewise, the second elongate fairing sleeve covers at least a portion of the second elongate support member, and is configured to rotate around the second elongate support member.

[0012] In still another aspect of the invention, a method comprises providing an elongate object having a first aerodynamic drag coefficient. The method further comprises mounting a rotatable cover having a second aerodynamic drag coefficient on the elongate object. The second aerodynamic drag coefficient is less than the first aerodynamic drag coefficient.

BRIEF DESCRIPTION OF THE DRAWINGS

[0013] Having thus summarized the general nature of the invention, certain preferred embodiments and modifications thereof will become apparent to those of ordinary skill in the art from the detailed description herein having reference to the figures that follow.

[0014] **FIG. 1** is an elevation view of a pole equipped with an elongate rotatable fairing to reduce an aerodynamic drag force acting on the pole.

[0015] **FIG. 2** is a cross-sectional view of the pole illustrated in **FIG. 1** taken along line 2-2.

[0016] **FIG. 3** is a cross-sectional view of the elongate rotatable fairing illustrated in **FIG. 1** taken along line 3-3.

[0017] **FIG. 4** is an elevation view of a traffic signal equipped with horizontal and vertical elongate rotatable fairings.

[0018] FIG. 5 is an elevation view of a pole equipped with an elongate rotatable fairing and a safety shield.

[0019] FIG. 6 is a partial elevation view of a light fixture illustrating a preferred means of rotatably securing an elongate rotatable fairing to a pole.

[0020] FIG. 7 is a cross-sectional view of the light fixture illustrated in FIG. 6 taken along line 7-7.

[0021] FIG. 8A is a cross-sectional view of the elongate rotatable fairing of FIG. 6 taken along line 8-8.

[0022] FIG. 8B is a cross-sectional view of an elongate rotatable fairing configured for use with a square support member.

[0023] FIG. 8C is a cross-sectional view of an alternative embodiment of an elongate rotatable fairing.

[0024] FIG. 9 is an elevation view of a pole equipped to support an elongate rotatable fairing at a pivot point.

DETAILED DESCRIPTION OF PREFERRED EMBODIMENTS

[0025] As discussed above, it is desired to develop outdoor objects such as poles, road signs and raised light fixtures that can withstand strong winds. However, it is also desired to construct such outdoor objects without necessitating the use of heavy sidewalls and strong foundations. Certain embodiments of the present invention described herein address these desires, advantageously allowing the weight and expense of outdoor objects such as poles, road signs and raised light fixtures to be reduced without sacrificing ability to withstand strong winds. In particular, placement of a rotatable fairing on at least a portion of the object reduces the aerodynamic drag force acting thereon, thereby making the object able to withstand stronger winds.

[0026] FIG. 1 illustrates a pole 100 anchored in the ground 102 at a foundation 104. The presence of any wind around the pole 100 will cause an aerodynamic drag force \vec{F}_p to act on the pole 100. Therefore, if the pole 100 is placed in an outdoor environment, it will often be subject to the aerodynamic drag force \vec{F}_p . The magnitude of the aerodynamic drag force \vec{F}_p depends on, among other things, the velocity of the wind, the cross-sectional area of the pole 100, the shape of the pole 100, and the drag coefficient C_d . The drag coefficient C_d is given by the following expression:

$$C_d = \frac{4D}{rAv^2},$$

[0027] wherein D is the drag, r is the density of air, A is the reference area, and v is the velocity of the wind. FIG. 2 is a cross-sectional view of the pole 100 subject to aerodynamic drag force \vec{F}_p .

[0028] Still referring to the embodiment illustrated in FIG. 1, the pole 100 is at least partially covered by an elongate rotatable fairing 110. The elongate rotatable fairing 110 is optionally displaced from the ground by a height h . As shown in the cross-section illustrated in FIG. 3, the elongate rotatable fairing 110 has a streamlined shape that is prefer-

ably configured to reduce the aerodynamic drag force \vec{F}_p acting upon the pole 100. Examples of such streamlined shapes include a teardrop shape or an airfoil shape, although other shapes may also be used to reduce the aerodynamic drag force \vec{F}_p acting upon the pole 100.

[0029] Therefore, in the regions of the pole 100 covered by the elongate rotatable fairing 110, a reduced aerodynamic drag force \vec{F}_f acts on the elongate rotatable fairing 110. Because the elongate rotatable fairing 110 is freely rotatable, the aerodynamic drag force \vec{F}_p can be reduced regardless of the direction of the wind. In a preferred embodiment, the elongate rotatable fairing 110 comprises a lightweight material such as a plastic, although in alternative embodiments, other materials may be used, such as rubber, aluminum or fabric. Such materials permit the pole 100 to withstand strong aerodynamic drag forces at lower cost, and using lighter materials, than would otherwise be possible using conventional design techniques.

[0030] Although the pole 100 illustrated in FIG. 1 supports a light fixture 120, one of ordinary skill in the art will recognize that the elongate rotatable fairing 110 can be used in conjunction with an unlimited variety of other outdoor objects, such as sign posts, traffic signals, stakes, and horizontal members. For example, FIG. 4 illustrates a traffic signal assembly 130 having a horizontal support member 132 and a vertical support member 134, each at least partially covered by an elongate rotatable fairing 110. Furthermore, one of ordinary skill in the art will recognize that the support members that are at least partially surrounded by an elongate rotatable fairing 110 need not have a cylindrical cross section, but can also have other cross-sectional shapes, such as ovals, rectangles or other polygons.

[0031] In certain embodiments, such as illustrated in FIG. 5, a stationary safety shield 140 is positioned below the elongate rotatable fairing 110. In one preferred embodiment, the stationary safety shield 140 comprises a cylindrical disk. In such embodiments, the stationary safety shield 140 is configured to prevent the elongate rotatable fairing 110 from striking objects placed below the elongate rotatable fairing 110. Specifically, if the wind direction changes abruptly, the elongate rotatable fairing 110 may rotate suddenly, creating the risk of collision with an object having a height greater than h , such as a bystander's head. The presence of stationary safety shield 140 reduces the risk of such collision.

[0032] FIGS. 6 and 7 illustrate a preferred technique for rotatably attaching the elongate rotatable fairing 110 to the pole 100. In such embodiments, a stationary support plate 150 is secured to the pole 100 at the height h at which the elongate rotatable fairing 110 is to be rotatably attached to the pole 100. Preferably, a plurality of ball bearings 152 are disposed around the circumference of the stationary support plate 150. An elongate rotatable fairing 110 equipped with a lower closed end plate 112 is then positioned atop the stationary support plate 150, such that the lower closed end plate 112 rests on the plurality of ball bearings 152. In such embodiments, the elongate rotatable fairing 110 can freely rotate around the pole 100 on the ball bearings 152. Furthermore, the weight of the elongate rotatable fairing 110 is supported by the stationary support plate 150.

[0033] FIG. 8A illustrates a cross-sectional view of a preferred embodiment of the elongate rotatable fairing 110

shown in FIG. 6 taken along line 8-8. In such embodiments, the elongate rotatable fairing 110 further comprises a plurality of optional interior support members 114. Interior support members 114 preferably prevent the elongate rotatable fairing 110 from buckling or otherwise being distorted when subjected to large aerodynamic drag forces \vec{F}_r . Additionally, FIG. 8A illustrates that in certain embodiments, a gap 116 exists between the pole 100 and an interior surface 118 of the elongate rotatable fairing 110. In such embodiments, gap 116 is preferably filled with a lubricant to reduce friction between the interior surface 118 of the elongate rotatable fairing 110 and the pole 100.

[0034] FIG. 8B illustrates that the elongate rotatable fairing 110 can be used in embodiments in which the pole 100 has a non-circular cross-sectional shape. In such embodiments, at least a portion of the covered portion of the pole 100 is fitted with a stationary circular adapter 119. Preferably, the stationary circular adapter 119 has a diameter that is less than the diameter of the interior surface 118 of the elongate rotatable fairing 110. In such embodiments, the elongate rotatable fairing 110 can freely rotate around the pole 100, despite the fact that the pole 100 has a non-circular cross-sectional shape.

[0035] FIG. 8C is a cross-sectional illustration of an alternative embodiment of an elongate rotatable fairing 110. In such embodiments, the elongate rotatable fairing 110 further comprises a plurality of internal guides 160. Each of the internal guides 160 preferably comprises a series of ball bearings configured to rotate along the surface of the pole 100. This configuration preferably prevents the elongate rotatable fairing 110 from buckling or otherwise being distorted when subjected to large aerodynamic drag forces \vec{F}_r . Additionally, the presence of the internal guides 160 further promotes free rotation of the elongate rotatable fairing 110 around the pole 100.

[0036] FIG. 9 illustrates another technique for rotatably securing the elongate rotatable fairing 110 to the pole 100. In such embodiments, the elongate rotatable fairing 110 preferably further comprises an upper closed end plate 113. This configuration allows the elongate rotatable fairing 110 to be slid over the pole 100, which preferably comprises a pivot point 106. Thus, the pivot point supports the interior side of the upper closed end plate 113, thereby allowing the elongate rotatable fairing 110 to rotate around the pole 100. In other embodiments, the interior side of the upper closed end plate 113 further comprises a cupped support receptacle configured to receive the pivot point 106 of the pole 100. Such embodiments allow the elongate rotatable fairing 110 to rotate around the pole 100 with reduced frictional losses.

[0037] One of ordinary skill in the art will recognize that other suitable means of rotatably securing the elongate rotatable fairing 110 to the pole 100 exist. Such means include, but are not limited to, bearing joints and sliding joints. Such alternative means of rotatable attachments are fully compatible with the rotatable fairing described herein.

[0038] The various embodiments described herein permit outdoor objects such as poles, signs and raised light fixtures to withstand strong aerodynamic drag forces. Specifically, covering at least a portion of such objects with an elongate rotatable fairing reduces the aerodynamic force acting upon such objects. This allows such objects to be manufactured at

lower cost, and using lighter materials, than would otherwise be possible using conventional design techniques. Additionally, reduction of the aerodynamic drag force acting on such objects increases the safety of such objects by reducing the likelihood of such objects toppling or becoming airborne.

[0039] The above presents a description of various preferred embodiments of a rotatable fairing, and of the manner and process of making and using it, in such full, clear, concise and exact terms as to enable any person skilled in the art to which it pertains to make and use such a rotatable fairing. This rotatable fairing is, however, susceptible to modifications and alternate constructions from that discussed above which are fully equivalent. Consequently, it is not the intention to limit this rotatable fairing to the particular embodiments disclosed. On the contrary, the intention is to cover all modifications and alternate constructions coming within the spirit and scope of the rotatable fairing as generally expressed by the following claims, which particularly point out and distinctly claim the subject matter of the rotatable fairing.

What is claimed is:

1. A rotatable fairing apparatus comprising:

a vertical support member anchored in a foundation, wherein the vertical support member is subjected to an aerodynamic drag force; and

a hollow elongate fairing sleeve covering at least a portion of the vertical support member and rotatably secured to the vertical support member, the hollow elongate sleeve having a shape configured to reduce the aerodynamic drag force acting on the vertical support member.

2. The rotatable fairing apparatus of claim 1, wherein the hollow elongate fairing sleeve is rotatably secured to the vertical support member by at least one bearing joint.

3. The rotatable fairing apparatus of claim 2, wherein the hollow elongate fairing sleeve further comprises a first end, a second end opposite the first end, and bearing joints positioned at the first and second ends.

4. The rotatable fairing apparatus of claim 2, further comprising a lateral support structure disposed on an interior side of the hollow elongate fairing sleeve, the lateral support structure comprising a plurality of bearings configured to facilitate rotation of the hollow elongate fairing sleeve around the vertical support structure during subjection of the aerodynamic drag force.

5. The rotatable fairing apparatus of claim 1, wherein:

the vertical support member further comprises a tapered end structure; and

the hollow elongate fairing sleeve further comprises a cupped support receptacle disposed within an interior side, the cupped support receptacle configured to receive the tapered end structure.

6. An apparatus comprising:

an elongate support member; and

an elongate fairing sleeve having a first axis, the elongate fairing sleeve covering at least a portion of the elongate support member, configured to rotate around the elongate support member on the elongate fairing sleeve first axis, and substantially shaped to reduce an aerodynamic drag force acting on the elongate support member.

7. The apparatus of claim 6, wherein:

the elongate support member further comprises a tapered end structure; and

the elongate fairing sleeve further comprises a cupped support receptacle disposed within an interior side, the cupped support receptacle configured to receive the tapered end structure.

8. The apparatus of claim 6, wherein the covered portion of the elongate support member has a first aerodynamic drag coefficient that is greater than a second aerodynamic drag coefficient of the elongate fairing sleeve.

9. The apparatus of claim 6, wherein the elongate support member is oriented vertically, and is anchored in a foundation structure.

10. The apparatus of claim 9, wherein the elongate fairing sleeve has an upper end and a lower end opposite the upper end, such that the lower end is displaced from the foundation structure by a first height.

11. The apparatus of claim 10, further comprising a safety shield attached to the elongate support member and displaced from the foundation structure by a second height, such that the second height is less than the first height.

12. The apparatus of claim 6, wherein the elongate support member has a circular cross-sectional profile.

13. The apparatus of claim 6, wherein the elongate support member has a rectangular cross-sectional profile.

14. The apparatus of claim 13, wherein the elongate support member has a square cross-sectional profile.

15. The rotatable fairing apparatus of claim 6, wherein the hollow elongate fairing sleeve is rotatably secured to the vertical support member by at least one bearing joint.

16. The rotatable fairing apparatus of claim 15, wherein the hollow elongate fairing sleeve further comprises a first end, a second end opposite the first end, and bearing joints positioned at the first and second ends.

17. The rotatable fairing apparatus of claim 15, further comprising a lateral support structure disposed on an interior side of the hollow elongate fairing sleeve, the lateral support structure comprising a plurality of bearings configured to facilitate rotation of the hollow elongate fairing sleeve around the vertical support structure during subjection of the aerodynamic drag force.

18. An apparatus comprising:

an elongate support member;

an elongate fairing sleeve having a longitudinal axis and covering at least a portion of the elongate support member; and

means for attaching the elongate support structure to the elongate fairing device, such that the elongate fairing device can rotate around the elongate support member on the elongate fairing sleeve longitudinal axis.

19. The apparatus of claim 18, wherein the covered portion of the elongate support member has a first aerodynamic drag coefficient that is greater than a second aerodynamic drag coefficient of the elongate fairing sleeve.

20. The apparatus of claim 18, wherein the elongate support member has a rectangular cross-sectional profile.

21. The apparatus of claim 20, wherein the elongate support member has a square cross-sectional profile.

22. The apparatus of claim 18, wherein the elongate support member is oriented vertically, and is anchored in a foundation structure.

23. The apparatus of claim 22, wherein the elongate fairing sleeve has an upper end and a lower end opposite the upper end, such that the lower end is displaced from the foundation structure by a first height.

24. The apparatus of claim 23, further comprising a safety shield attached to the elongate support member and displaced from the foundation structure by a second height, such that the second height is less than the first height.

25. An apparatus comprising:

a first elongate support member;

a second elongate support member that is attached to the first elongate support member;

a first elongate fairing sleeve covering at least a portion of the first elongate support member, and configured to rotate around the first elongate support member; and

a second elongate fairing sleeve covering at least a portion of the second elongate support member, and configured to rotate around the second elongate support member.

26. A method comprising:

providing an elongate object having a first aerodynamic drag coefficient; and

mounting a rotatable cover having a second aerodynamic drag coefficient on the elongate object, wherein the second aerodynamic drag coefficient is less than the first aerodynamic drag coefficient.

27. The method of claim 26, further comprising orienting the elongate object vertically, and anchoring the elongate object in a foundation structure.

28. The method of claim 27, wherein the elongate object has an upper end and a lower end opposite the upper end, such that the lower end is displaced from the foundation structure by a first height.

29. The method of claim 28, further comprising attaching a safety shield to the elongate object such that the safety shield is displaced from the foundation structure by a second height, wherein the second height is less than the first height.

* * * * *