

(19) World Intellectual Property Organization
International Bureau



(43) International Publication Date
21 February 2002 (21.02.2002)

PCT

(10) International Publication Number
WO 02/14990 A1

- (51) International Patent Classification⁷: G06F 1/00
- (21) International Application Number: PCT/SE01/01739
- (22) International Filing Date: 10 August 2001 (10.08.2001)
- (25) Filing Language: Swedish
- (26) Publication Language: English
- (30) Priority Data:
0002895-1 11 August 2000 (11.08.2000) SE
0003244-1 13 September 2000 (13.09.2000) SE
0003629-3 9 October 2000 (09.10.2000) SE
0004939-6 29 December 2000 (29.12.2000) SE
0101529-6 30 April 2001 (30.04.2001) SE
0101850-6 28 May 2001 (28.05.2001) SE
- (81) Designated States (*national*): AE, AG, AL, AM, AT, AU, AZ, BA, BB, BG, BR, BY, BZ, CA, CH, CN, CO, CR, CU, CZ, DE, DK, DM, DZ, EC, EE, ES, FI, GB, GD, GE, GH, GM, HR, HU, ID, IL, IN, IS, JP, KE, KG, KP, KR, KZ, LC, LK, LR, LS, LT, LU, LV, MA, MD, MG, MK, MN, MW, MX, MZ, NO, NZ, PL, PT, RO, RU, SD, SE, SG, SI, SK, SL, TJ, TM, TR, TT, TZ, UA, UG, US, UZ, VN, YU, ZA, ZW.
- (84) Designated States (*regional*): ARIPO patent (GH, GM, KE, LS, MW, MZ, SD, SL, SZ, TZ, UG, ZW), Eurasian patent (AM, AZ, BY, KG, KZ, MD, RU, TJ, TM), European patent (AT, BE, CH, CY, DE, DK, ES, FI, FR, GB, GR, IE, IT, LU, MC, NL, PT, SE, TR), OAPI patent (BF, BJ, CF, CG, CI, CM, GA, GN, GQ, GW, ML, MR, NE, SN, TD, TG).
- Published:
— with international search report

- (71) Applicant and
(72) Inventor: FÄLTSKOG, Lars [SE/SE]; Airtex KB, Torkils väg 17, S-192 73 Sollentuna (SE).

For two-letter codes and other abbreviations, refer to the "Guidance Notes on Codes and Abbreviations" appearing at the beginning of each regular issue of the PCT Gazette.

(54) Title: DISTRIBUTION OF MEDIA CONTENT, WITH AUTOMATIC DELETION

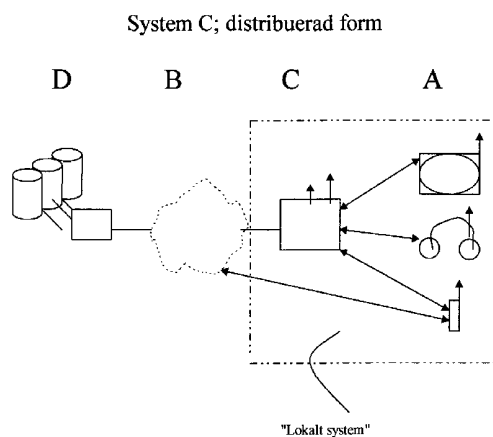

(57) Abstract: The present invention comprises a system for distribution and rendering of media content comprising a server (C1, C2, ...) for distribution of media content, and at least one terminal (A1, A2, ...) for ordering, reception, storing and rendering of media content. The server comprises a transmitter (1), a receiver (3), a processor (5), a memory (7), a software program (9), and a mobile unit or adapter of electro mechanical media (10), and is adapted for reception of an order of an audio- and or visual media content from a terminal, for ordering and reception of said media content by means of a data file from a database (D1, D2, ...), which comprises media content, and for transmission of said media content by means of a data file to the terminal. The terminal comprises a transmitter (21), a software program (29) and a means (31, 32, 33, 34) for rendering of media content, and a means (34, 36) to instruct a transmitter to submit an order to said server where said order comprises a selection of said media content, at which said receiver is adapted for reception of said selected media content form said server by means of a data file, and said rendering device is adapted for rendering of said ordered and received media content. The terminal comprises in particular a means (29) for automatic deletion of said ordered and received media content by means of a data file immediately after the expiration of a limited period of time.

WO 02/14990 A1

DISTRIBUTION OF MEDIA CONTENT WITH AUTOMATIC DELETION.

TECHNICAL FIELD

5 The present invention refers to the distribution of content from one server to at least one terminal, and for rendering of content in the said terminal. More particular the invention refers to a system comprising a server - terminal combination, the server itself, the terminal, a procedure for distribution and rendering, and finally a computer program to execute the procedure.

10

TECHNICAL STANDPOINT

15 Todays cellular networks are constructed in order to interact and function with both the fixed public telecom network, PSTN, and digital datacom networks like ISDN. A common characteristic is that these networks are circuit switched, only capable to handle relatively narrowband traffic.

20

In opposite thereto, are the fast growing IP based networks, or internet and intranet, packetswitched networks, that can handle very high bandwidth. The users can fully take advantage of the high bandwidth through different types of fixed connections, in order to download different types of data files, multimedia etc. For the major part of the mobile and wireless terminal users there are no similar connectivity techniques today.

25

There is an intensive work going on to overcome these limitations in bandwidth for wireless systems in order to provide packetswitched networks particularly suitable for broadband transmission of digital files, realtime video etc. Consequently earlier standards for the air interface, that were designed to optimize common two-way voice transmission, now have been modified in order to allow duplex

transmission of packet switched data at relatively low speed over the radio interface. One example of such standard is the GPRS - radio interface for GSM, that is described in the GSM Technical Specification 94.60 published of the European Institute for Telecommunication Standards, ETSI. Further it can be noticed that a substantial part of the bandwidth requirements belongs to the asymmetric category, where the information that is sent to a mobile terminal, the so called downlink in the radio environment, typically requires a lot more bandwidth than the information that is sent in the other direction from the terminal, the so called up-link. Examples of such asymmetric applications are the digital television and the video-on-demand (VOD). For such applications the radio interfaces DVB and DAB have been standardized.

When Mobile Internet, for example downloading of files or realtime sequencies, so called streaming video, to a mobile terminal, becomes available for the major part of the endusers, it could be assumed that transmission of different types of multimedia, music, computergames etc, becomes widely spread, as the case is today regarding downloading of music files, for example, via the fixed internet.

At the same time as distribution of media is simplified and gets more inexpensive even for endusers, via modern communication systems available today, it seems that there is a negative tendence regarding users willingness to act up to copyright laws. The reasons for this is for example the degree of simplicity with which the piracy copying could be performed as well as the relatively high prices on copyright protected material.

These copyright laws are not particularly suited for various services, products, and compromises thereof, as modern communication systems may offer today. Further such services or products may be constructed and produced in a number of countries having less effective or non-existing legislation. Thereafter these products and

services might be offered to endusers in another country, sometimes via a third country.

As a consequence there is a need, both from content providers as well as endusers, of a system that can offer and deliver content on a wireless carrier, quickly, simple and flexible, at a low cost, in a way that prevents pirate copying or other illegal use of copyright protected material.

SUMMARY OF THE INVENTION

Thus, it is an object of the present invention to enable a mobile system for distribution and rendering of media content, e.g. music, pictures and/or text, comprising one server and at least one terminal that provides distribution of media content to a terminal as well as rendering of media content from a terminal, in particular a portable wireless terminal having limited use restrictions implemented, at which one purpose is to enable consumption of media content at a lower cost, in favour of the terminal enduser.

A second object of the present invention is to provide a mobile system for distribution and rendering of media content, that prevents illegal copying, so called pirate copying, of the said media content.

It is a third object of the present invention to provide a mobile system for distribution and rendering of media content, that particularly comprises a plurality of standards and techniques for the air interface, for communication and transmission of orders as well as distribution of media content. According to this aspect there is a wish to use techniques for broadcasting in combination with other techniques for wireless transmission.

The forth object of the present invention is to provide such a mobile

system for distribution and rendering of media content that is secure, reliable, simple, robust and that can be implemented at a relatively low cost.

5 Further it is an object of the invention to provide a terminal and a server for use in the said system.

Finally it is an object of the present invention to provide a procedure for ordering, reception, storing, and rendering of a media content, and that limits the storing and rendering, and as a consequence limits the right of consumption of the said media content.

10 The above mentioned objects are achieved referring to the present invention by means of a system, a terminal, a server, a procedure and a computer program according to the enclosed patent claims. The advantage of the present invention enables a compromise between the wish of consumers to have a non-expensive and simple way of
15 downloading media content and, on the other hand, the wish of media content providers that the pirate copying shall cease. By means of the present invention, a distribution system for media content is achieved, at which the limited rights of consumption (consumption
20 during a given period of time) is an important feature. In this respect the consumer can, hopefully at a low cost, download media content, e.g. music, which is momentarily of interest, and render the media content, e.g. listen to the music, during a specified, limited period of time. By means of individual terminals, dedicated
25 for the system, different types of protection against pirate copying may be applied into the said terminals. The protection against pirate copying may be implemented in the software as well as in the hardware. Further the terminal may be equipped with a mechanical lock or seal, constructing no output ports. Alternatively, output
30 ports are provided that are locked for use with other facilities than dedicated, accessories for rendering, e.g. earphones, displays, video screens or virtual (video) glasses.

Further advantages of the present invention, as well as characteristics of the same, appears in the description below.

BRIEF DESCRIPTION OF THE DRAWINGS

5 Further aspects and details of the invention will appear from the following description of preferred embodiments, reference being made to the enclosed drawings. These drawings are shown to illustrate the present invention, and shall therefor not, in any case, restraint the same.

10 Fig. 1. illustrates a schematic view of a centralized system, at assymetric communication using a plurality of carrier networks, according to the present invention.

Fig. 2. illustrates a schematic view of a distributed system, at communication using a plurality of carrier networks and/or portable carriers, according to the present invention; D:
15 Database/serversystem

B: Carrier network and/or portable media

C: Intermediate database/server

20 A: Enduser terminal inclusive or in combination with rendering accessories; videoscreen, earphones, loudspeakers, virtual video data glasses etc

25 Fig. 3. illustrates, schematically, an embodiment of a terminal, which is part of the system according to fig. 2. The terminal and its accessories are mounted as one unit in the same shell or separately, connected to each other by means of a fixed connection or an air interface, according to the present invention.

Fig. 4. illustrates, schematically, an alternative embodiment of a terminal/server, fixed or mobile, which is part of the system according to fig. 2, according to the present invention.

Fig. 5. illustrates, schematically, an embodiment of a G module, in the system, which serves as an interface for security and limited rights of consumption, according to the present invention.

5 Fig. 6. illustrates, schematically, an example of a structure for G module functions and related keys.

DESCRIPTION OF PREFERRED EMBODIMENTS

10 In the following description, with describing not limiting purpose, specific details are given, such as particular embodiments, applications, techniques, procedures etc, in order to provide a thorough understanding of the present invention. It should however be evident to the experts in the field that the present invention could be performed and practised in other applications and embodiments that
15 deviates from the described details. In other cases, detailed descriptions of wellknown procedures, protocols, embodiments or circuits are omitted in order not to overshadow or charge the description of the present invention with redundant details.

20 A new market opens up for interactive multimedia. With increased datarates and bandwidth, a number of different application areas having commercial potential appears, particularly with focus on personal interactive access and highspeed downloading of data from central or intermediate multi database systems through terminals which are fixed, portable, embedded (in clothes, machines, vehicles
25 etc) or mobile. Ordering and downloading takes place according to actual circumstances and the requirements of the application, e.g. depending on the enduser environment, actual net capacity, radiocoverage, connectivity and available access interfaces. In some cases there is an advantage to perform ordering and downloading via an intermediate server.

30 One aspect of a potential service, based on one of the preferred

embodiments of the system, is to provide to the enduser a possibility to order and download relatively large amounts of his/her preferred media content or data, quick and easy, where-ever and whenever he/she prefers. As a consequence a complementing service is provided as an alternative to timeconsuming, complecated and even illegal downloading via fixed connected computers. The vision is to provide a service that is convenient and pleasant and thereby contributes to a decreased level of stress, as it allows the enduser to eliminate some of the planning moments.

Further the intention is to develop applications and related terminals and rendering accessories for each field with focus on high quality and putting the media content or data in the respective field into the market front. The development is not restricted to the below indicated areas, which should be seen as examples.

- Entertainment services, e.g. music, video, games, concerts exhibitions etc -
- Renting services (of copyright protected material and events) -
- Advertisement and promotion services
- Subscription services (e.g. electronic distribution of music, video, books, newspapers, ads)
- Positioning services (in combination with mentioned services) -
- Car and MC related services (entertainment and positioning)
- Services related to service points and malls (e.g. petrolstations, restaurants, airoports, hotels public meeting places etc)
- Boat and ferry services
- Handicap services
- Services for mobile professionals
- Society and public related services (e.g. information, museums, historical sites, edutainment etc) -
- Services related to public and private transports (e.g. buses, ferries, trains, airoplanes, underground, travel entertainment etc)
- Tourism and sport services (e.g. information, entertainment, games

related to various indoor and outdoor activities)

- Services for transmission of photos, video, art etc

Focus is on services based on Personal Secure Wireless Highspeed Interactive Media (PSWHIM).

5

The present invention is based on existing techniques, standards, products, methods and systems in combination with the rules of limited utilization and consumption (LUC) of media content. The communication between the server and the terminal is asymmetric. Ordering and downloading of data and media content is performed by means of fixed, handheld, embedded, mobiles or PC's having relevant interfaces and modems. The application platform (PSWHIM) is considered as a so called middleware and serves as a base for development of embodiments and solutions.

10

15

With reference to the enclosed drawings, the present invention is now described. It comprises in its most general embodiment a media system that enables effective and simple ordering and downloading of data and media content from databases D to different types of terminals A. Storing of data, system management, monitoring, registration, billing and administration is performed centrally or locally in a fixed and/or mobile server C.

20

25

System for interactive and asymmetric ordering with terminal comprising or in combination with a device for ordering and or rendering of media content, via a carrier network B and highspeed downloading via carrier network B, or via a distributed fixed or mobile server C, from databases D. Alternatively ordering and downloading from D to C is performed via a portable or mobile media PM.

30

The application platform F is a server terminal application and is carrier and terminal flexible. The application F handles, content management, administration, system monitoring and software implemented encryption and limited use criterias. It takes into

consideration present load in the carrier. It compares and selects content media from a database at lowest price. It also comprices a system for payment E of the services, taking into consideration requirements from respective embodiment with involvement at level A, B, C and D (fig. 1).

The application platform F is compatible with the G module (that comprices a secure or sealed module for mainly hardware implemented secure communication and limited use rules and criterias) that is implemented according to system requirements for a specific server terminal combination. Module G handles secure communication, encryption, verification of terminal identities and comprices algorithms, keys and other secure functions in order to protect copyright protected material against unauthorized use. Further each terminal may connect to an ordering and rendering device, which as a consequence has to present its identity to said server or terminal respectively. External non-authorized applications can not be connected to the system.

An order is submitted from a terminal to a server which executes the order. The media content data files are then encapsulated into a format that comprices relevant parameters for transmission from a server to a terminal, e.g. verification codes (for terminal/device, memory, I/O, etc), encryption codes and keys, relevant radio protocols, TCP/IP headers, limited use criterias, control flags, authorized aplets etc. The datafiles are packaged and encapsulated into secure data package frames in the central server. The said encapsulated datafiles are then transmitted to a distributed server where it is stored in an encrypted format. Alternatively said encapsulated datafiles are transmitted directly to a terminal in which it is received and stored in an encrypted format until the rendering process is started. There is a requirements that no other functions, e.g. play, copy, transmission etc, may be performed until the limited use functions are completed. The limited use functions

comprises restrictions for how long time a particular data file is allowed to remain in the memory of the enduser terminal. There is also a relation between the limited period of time and the number of replays and the size of capacity of the memory respectively.

5 The principle for secure distribution of copyright protected material is based on that a data file is transmitted from the memory of a server to the memory of a terminal. Several module G functions may be implemented in relation to a SIM card and or smart card. The
10 verification of terminal identity is one of them. As one way of implementation is to use a TCP/IP format for transmission and encapsulation there is a requirement of a code for conversion of security keys in the terminal.

There is a requirement to encode datafiles for transmission and to
15 keep corresponding keys for decoding in the terminal safely. This is preferably done via a hardware implemented and sealed G module in the terminal. The terminal G modul comprises data of parameters like account ID, content version, Limited Use and Consumption criterias and restrictions (LUC), etc. Before the media content datafile is
20 downloaded to the terminal corresponding parameters, enclosed in the encapsulated datafile are verified and matched against the G modul parameters which are already located safely in the terminal, e.g. in relation to a SIM card and or smartcard or safely integrated in an asic circuit.

25 There is a requirement to protect the terminal memory, e.g. fixed memory, mobile memory, smartcard, SIMcard, PCMCIA, electromagnetical memory, portable media etc. The memory or part of it is erased if it is disconnected or subject to other unauthorized use. This concerns only datafiles marked with limited use criteria (LUC), as the price
30 for these datafiles are considerably lower than other datafiles that have been required more permanently by the enduser.

A consequence of lower prices for media content for "renting

services" requires more or less "waterproof" terminals. This means that also the I/O ports and further the connected rendering devices are subject to secure handling in the distribution chain of media content. In particular a rendering device shall not construct any outgoing I/O ports than what is authorized for use in the system.

The G module also comprises a function for comparison of registered downloads, made from a server in relation to predefined LUC time periods, against registered digital analogue conversions actually performed in the terminal and its device. These registered downloads serve as a statistics base for a payment system E. The system requires regular reports of said registrations, preferably in connection to each login of a terminal to the said system. The consequence of non-reporting or failed reporting from the terminal to the server results in a disconnection between the terminal and the server.

The payment system comprises a system E, that administrates and distributes costs and revenues related to media content, licencies, royalties etc. The preferred embodiment comprises a system for prepayments, e.g. POT, an enduserlicence procedure, where the system administrates and deduct costs for downloaded datafiles in relation to the accumulated time of use of said downloaded media content. Alternatively the enduser is debited via the regular telephone or creditcard bill, however such system requires a more sophisticated solution to meet the LUC requirements.

Detailid description of the system

Terminal A

Terminal A is included in the application platform F which is adapted

5 according to requirements of the present embodiment, e.g. type of terminal, centralized or distributed user access; buses, trains, cars etc. The terminal and its devices can be mounted or integrated to each other in one unit or connected to each other via fixed or wireless interfaces, e.g. music players, video displays, earphones, headsets, virtual data/video glasses etc. In the following text the word terminal is preferred as a composed concept for the equipment of the enduser.

10 The design of terminals and user interfaces is characterized by a simplicity and robustness, where logon procedures and security functions are executed automatically without disturbing the enduser.

- Terminal A comprises the following principal functions;

15 Given a valid user licence, code and or card, each terminal that is connected to the system is subject to an automatic identification and verification. The terminal shall perform the following functions; - Use and translate IP code and headers and translate to SIM system code, if necessary.

20 - Order and download a virtual table of contents , e.g. via a WAP menu or via voice recognition.

- Order and submit a specific ID number corresponding to a specific unit of media content file, e.g. a piece of music or a video.

- Download and render said media content datafile

- Control and execute limited use functions before any other function is performed.

25 The following is a categorization of terminals, devices subject to implementation of limited use consumption criterias (LUC) and their field of application;

30 - Fixed terminals; PC-terminals and servers including modem, PCMCIA etc. For use at home or public places like malls, petrolstations, bus stops, hotels, skiresorts etc. The fixed terminals may be accessed by mobile and wireless terminals , handy's, PDAs, or headsets.

- Semi-mobile terminals.

Servers and multimedia boxes for use in public transports, e.g. trains, buses, airoplanes. The semimobile terminals/boxes may be accessed by mobile and wireless terminals, handys, PDAs, headsets etc.

- Mobile terminals

and multimedia boxes. For use in private transports and cars. The mobile terminals/boxes may be accessed by mobilephones, handhelds, PDAs etc.

- Handheld, personal

devices PD, mobilphones and other very light and small terminals, which may access other servers, boxes, mobile terminals etc. Under circumstances and when the LUC security is guaranteed, and satisfying licence conditions are fulfilled, this category of terminals may access similar terminals.

- Embedded

terminals. These terminals may be enclosed in clothes, watches, cameras and other machines etc.

- Rendering devices such as video and film display, earphones, loadspeakers that are connected to said categories of terminals. The basic requirement is that an identification can be performed. The transmission may in some local and controlled circumstances be in analogue mode, consisting of hopping frequencies. However, normally in the case where the content media consists of music or other sounds, the requirements of a rendering device connected to the system and a terminal in the said system is that the said device shall not have any memory, it shall be able to identify itself for the system and the said terminal. The identification functionality may be hardware implemented in the rendering device. The digital analogue conversion and the connection to a membrane which produces sound shall take place within a sealed component as close as possible to the human ear. The transmission between the terminal and the rendering device is thereby performed via a streamed format. Alternatively, the rendering device may comprise one or more of the terminal functions, e.g. microprocessor, memory etc

Principal components in a terminal A (fig 3);

- Transmitter 21
- Receiver 23
- Processor 25
- 5 - Memory 27
- Software 29
- Contactors, interface, I/O ports, for audio visual rendering 35;

Description and example of a terminal device;

- Rendering device; music player, video adapter/player, 32
- 10 -Display, screen, television, 31
- Earphones, 33
- Sealed module for digital analogue conversion in combination with a membrane to produce a sound without constructing any unauthorized output ports, 33b
- 15 - Virtual data video glasses, 34
- Line, dot and or barcode reader 42
- Virtual video data glasses; rendering of video and pictures, ordering and visualisation of table of contents by means of a spreadsheet, e.g. Excel, that comprices data about mediacontent, datafile ID, text and pictures, 34
- 20 - Man-machine interface; interaction and ordering by means of "one-button-multifunctionality", virtual pen that reads and writes, voice recognition, 36
- "Waterproof" security against transmission to non-authorized terminals or other devices, so called pirate copying, e.g. sealing of critical components, DA converters, memories, I/O ports encryption keys etc. If violation or unauthorized use the memory or part of it is automatically erased and further downloading of media content is not possible. The terminal is made in one unit and the devices are connected according to authorized standards, 41
- 25
- 30 - Memory; the memory should be fixed. Alternatively the system may accept a solution with a mobile memory, memory stick, PCMCIA, smartcard, optical memory etc, given that the imported media is

controlled by the module G. Further the power module controls an electronic circuit adapted to the memory which alarms when the memory is disconnected and as consequence erases the LUC files on it.

5 Intermediate database/server C.

Server C may be accessed by various types of terminals and rendering devices. It imports media content via fixed, wireless or portable media or electromechanical or optical media. Server C is a closed and locked system comprising a locked and encrypted harddisk. The LUC
10 media content should be possible to erase from said harddisk upon expiration of a predefined period of time.

- Fixed connected server C; Connection and updates are made on a regular basis via fixed lines. Server C is located at hotels, petrolstations etc, where the endusers may order and download via
15 their mobile or wireless terminals A.

- Mobil server C; located in a vehicle or a means of communication, public or private. Updates of media content is made via portable media or via wireless broadband, preferably at night time.

-Server C comprises an application platform F which allows terminal
20 endusers to submit an order to a central server, which then routes the order to nearest local distributed server. The file is in encrypted format as from the original central database until the LUC procedures in the enduser terminal are initiated.

Automatic control of the number of and accumulated time of downloaded
25 media content is done by means of a regular automatic mail, SMS or similar, which is submitted to the central billing function. Alternatively the central billing function polls a statistics file, comprising a record of predefined parameters, in server C, which is made available for scanning.

30 Server C (Fig. 4) comprises;

- Transmitter 1

-

Receiver 3

- Processor 5
- Memory 7,
- 5 - Software 9
- I/O ports and sealing 10.

Carrier networks B

Carrier networks comprises of wireless networks fixed networks, broadcast networks and or combinations of them. Alternatively various Portable Media is utilized to carry media content from the server to the terminal.

10 - Uplink, interactive; fixed connection, e.g. PSTN, X.25, ADSL, ATM, fiberoptics, etc wireless connection; GSM, Mobitex, GPRS, W-LAN/DECT, Hyperlan, Bluetooth/IRD, UMTS, WCDMA, satellite and other cellular highspeed standards for wireless transmission

15 - Downlink, highspeed channel; As for uplink but in addition DAB and DVB and other standards for extreme rate of downloading.

Module G; Secure ordering, reception, storing and rendering of media content.

20 The main object is to protect material and media content subject to copyrights. One precondition is that each terminal is defined as a unique identity in the system. The available techniques for this are the SIM card, smartcard technology or implementation via asic circuits. The latter gives a better protection of ID's.

25 Further the G module shall control and authorize data and media content which is imported to terminals, devices, portable media and audiovisual output I/O. ports.

The G module is integrated in a server terminal software and hardware. It utilizes automatic signing for identification of

imported data and media content. Non authorized data or media content can not be imported to the memory of the terminal. The G module identifies itself for G classified data, media content terminals and devices before any other identification or activities can start. The G module shall only handle unidentified data and media content with the purpose to validate said data and media content.

The encapsulated datafile is exported from the server to the terminal. The said datafile comprises code that initiates the, in the terminal, implemented LUC procedures and restrictions, e.g. initiating of a program that keeps track of how long time a specific LUC data file is stored in the terminal memory or in the smartcard memory.

Conversion, encryption and encapsulation takes place in the server which is centrally or intermediate located. The datafile is transmitted over relevant carrier network B or device to reach the terminal A. The datafile remain encrypted until the LUC functions in the terminal are initiated and executed, just before the digital analogue conversion is performed.

The object of the requirements of LUC rules and restrictions is to enable the submission of licences to distributors and endusers. The LUC modules are implemented both in the server and the terminal.

The G module system comprises the following components (fig. 5);
- Wireless interface , e.g. DAB, DVB, GSM,UMTS, Blåtand,IrD, W-lan etc) 78

- PM, portable media, e.g. portable memory, CD,DVD, minidisc,etc 71 -
EMD; elektromagnetical device; 73 -

Optical interface and or device,e.g. optical reader etc, optical memory,laser 88

- Limited use criterias module (LUC), 80

- Fixed memory (a mobile could be accepted only though security

corresponding to the level of a fixed memory is obtained, according to LUC criterias), 27

- Audio visual (digital/analogue) output, earphones, loudspeaker system, television set (to antenna input), video screens etc, 33

- Audio visual rendering device, including a "play" funktion. Before any function, like "play", could be performed the LUC procedure must be executed, 32

- Import control, 75

- Autentification,identification, "input" API's , license interface, 72

- Clock, 39

- Counter, 37

SPM (Safety Power Module, partial deletion of memory), function that erases data files which time period is exceeded. Serves also as a protection if the memory is disconnected or if a terminal cable is cut,40

- Algorithm for automatic encryption, decryption and generating of keys, 83

- Comparison and control function; the number of digital analogue conversions of media content in relation to predefined timeframes in the terminal is compared to the number of ordered and downloaded media content registered in the server, related to a specific account ID, 84

- SIM-card and or smart card,85

- Concersion from SIM ID to IP address and vice versa, 77

- Identification, autentification and matching of parameters, 61

G-module; Requirements

The G module shall identify every terminal, portable media or media content that is imported or connected to the system independantly of each other. In a preferred embodiment the "keys" are stored and hardware implemented component in a sealed G module of the terminal. The G module shall not allow import of data and media content via a

non-authorized API or terminal except of when data and media content is G classified or when the LUC user rules so permits. The G module shall identify terminals, related ordering and rendering devices and portable media that is connected to the system regarding the following parameters (which does not mean that all required parameters are indicated here): SIM ID, IP address and or account ID 61a, manufacturer 61b, version 61c, date 61d, code 61e, security certificate 61f, limited use criterias and restrictions, LUC, 61g.

The following requirements are valid for software packets that are transmitted between the module G related units of the system(modul G);

- Ability to identify the G module, software and or hardware, in the terminal and or device and initiate identification activities, 61, and restriction procedures and programs/aplets, clock 62a, counter 62b, memory priority 62c, power safety module 62d, statistics-control 62e etc

- Support different codes that are supported by different terminals. Encapsulation of media content code in relevant packet frame 63 is performed in the server.

- Ability to transmit characteristics of the terminal and its ordering and rendering device, portable memory and its capacity, I/O ports, in direction to the server etc 64.

- Ability to transmit information and specific user rules and restrictions regarding the terminal/device I/O etc characteristics to the server. Execution of enquiry in the server. Import to terminal authorized given a successful matching of compared keys and parameters. Upgrades to latest versions. 65.

- Support of indicated requirements with one data structure between for transmission of required data between the server and the terminal.

- The G module is supposed to function as an interface between standards, APIs and different media. All module G functions are performed autonomously. The overall intention is to minimize the time as from

when a user need appears, e.g. a wish to hear a specific piece of music, until this need has been satisfied and completed.

- The G module shall contribute to secure billing procedures, 68a. In one of the preferred embodiments the SIM ID is equal to the subscriber account ID. The G-module may convert or encrypt such ID account for security reasons and in order to match to relating systems and standards when transmitting data between server and terminal, 68b.

- Given a prepaid service, licenced access to data and media content files might be transferred to other terminals given that the media content files are encapsulated in a LUC format, which comprices parameters for verification of terminals and interfaces. In this case there is a requirement of the encapsulated datafile to comprice parameters that measures the utilized time of every datafile, which is then subject to deletion upon expiration of maximum time for said data file. A possible media for such transaction might be a smartcard memory which has a LUC "power safety module" (PSM) implemented 62d. Alternatively transfer of media content data files might take place given that required identified and verified data, keys, interfaces, account ID of the receiving terminal is properly handled and that said data, mainly account ID and digital analogue conversion activity records , is provided to the source server.

Important criterias for limited use of media content, LUC; It is important to state that the selected LUC criterias are related to the actual application, e.g. local or national billing, what kind of enduser environment, busses, trains, ferries, malls etc, type of terminal or intermediate server. Below is listing of the principal criterias, which does not exclude additional or other criterias in other situations or circumstances. -

LUC criterias and restrictions are always controlled and executed before any other activity could be executed in the terminal, or the

server. E.g. the status of the data files subject to importation, if they are permitted to be rendered or copied etc.

5 - Time. A flag, timestamp, and an applet in each encapsulated LUC data file which is subject to transmission and rendering. The said data file needs to "match" a clock program, which is preferably hardware implemented, in the object terminal to initiate the time counter. If there is no "match", the said data file will not be possible to render. The max_tim function is thus initiated at the moment when the terminal is authenticated, by means of the encapsulated media content data file, and further at the moment when the said data file is imported to the authorised terminal memory. When the predefined period of time is expired and max_tim has reached its maximum value, the said media content file is automatically erased from the terminal memory, 62a.

15 In the case where the said datafile is stored on a smartcard or similar the said datafile is automatically erased when the smartcard is disconnected from the terminal or as an alternative, given that the service is prepaid, the said encapsulated data file comprises a parameter status_tim that keeps record of the time status of each said datafile, when the portable media is not connected to a specific terminal.

25 One LUC requirement is to perform a status check of the present terminal memory related to a specific ID account, every time the terminal is logged on to the system. A record of relevant check of transmission activities is submitted to the server before any new orders can be executed, related to said ID account. If the orders exceeds the ID account limit, max_ID or if the check of ordered datafiles versus the registered activities in the terminal deviates from predefined check values, the ID account is blocked, 62b.

30 - Counter. A flag, counter stamp, and an applet in each encapsulated LUC data file which is subject to transmission and rendering. The counter registrates each time the media content files is rendered,

e.g. digital analogue conversion, and the counter parameter in the said encapsulated data file is updated, max_num. The counter parameter is related to the time parameter. A restriction for a combination of the two parameters max_tim and max_num is possible, e.g. accumulated time specifically for the rendering time of a media content file, which is more relevant in some embodiments, rather than a measurement of time which also comprises time for passive use of said media content. Alternatively only the quantity, max_num is measured, thus a subject to restricted use.

When the max value is exceeded for max_num or the combination of max_num and max_tim, the said media content data file is erased from the memory.

The counter is related to max_ID, e.g. the maximum quantity of downloads to a specific account. Also this function is preferably combined with the max_tim parameter. Upon expiration of the max_ID parameters in combination with max_tim and or max_num, the said media content data files are automatically erased from the terminal memory and the account ID is blocked, 62b.

The statistics and billing function is updated according to predefined parameters.

- Memory capacity, max_cap 62c. This parameter is related to the enduser price of the proposed service. The more capacity of a memory, the more media content files may be stored in the terminal and as a consequence the number of transmissions between the server and the terminal may be kept at a lower level with decreased costs for transmission. Another advantage of a higher capacity of memory is the possibility to compensate for possible insufficient radio coverage. On the other hand if the terminal has a small memory or no memory at all, ordering from a central or intermediate server must be done more frequently, and as a consequence the enduser prices depends more on the cost of transmission, but on the other hand the cost for memory decreases.

Given that media content is supposed to be provided to endusers at LUC conditions, e.g. a virtual jukebox principle, at constant enduser price for media content, the cost for transmission, and the cost for memory respectively, are thereby compared and may vary within the frame of what the enduser is prepared to pay for having access to his or her favourite content at any time where-ever it is.

The two cases requires different system solutions, which implies that the present invention may lead to the provision of a service that is based on

- sales of a media content licence together with terminals comprising a smartcard, or other means of memories, for time limited storing in said terminal memories comprising a code which constitutes a "lock" to dedicated content at the proposed low rates.

- sales of a media content licence by means of "streaming media, utilizing authorized terminals or devices where the media content files can not be stored in any memory, where the terminal and its code constitutes a "lock" to dedicated content at the proposed low rates.

In the two described cases the time parameter, max_tim in combination with the memory capacity parameter, max_cap constitutes a base for determination of the enduser price parameter.

Another requirement related to the memory capacity is that selected and stored media content may be erased and replaced by media content that has been ordered later, due to lack of memory space, according to the principle first in first out. As a consequence time parameter is measured and registrated for the "old" media content which is subject to deletion.

- Control function. Compares activities registered in the server against activities registrated in the terminal. This function also serves as a correction function, e.g. if a download or rendering activity is not properly performed, the statistics function is not updated.

- "Safety power

criteria". function. Mainly functions as a partial data file eraser, given input from the max_parameters and the control function. Erases the memory or parts thereof if said memory is disconnected from the terminal in an unauthorized manner, 62d. I

5 In order to execute the functions max_tim, max_num, max_ID, max_cap the following is required;

- The G module should be able to identify and handle ONE unit media content, e.g. one data file equal to a piece of music.

10 - Each (encapsulated) datafile is subject to individual identification and execution of said procedures according to the LUC procedures, e.g. automatic and partial deletion of each data file from its temporary address.

- Initialization of a jamsignal applied to media content datafiles. Said jam signal is generated in rendering devices as a consequence of exceeded LUC limits or unauthorized use. This function is generated by an applet which accompanies the said encapsulated media content data file. This function is an alternative to the automatic deletion functionality, 66. -

20 Upgrades and corrections thereof, in particular, the G module functions should be enabled by means of automatic downloading from the server to the terminal in connection to terminal log-on to the system.

Billing system E.

25 Debiting of the enduser is made via an account ID, e.g. SIM identity or other secure codes preferably related to a card technology. The following alternatives are proposed;

30 - There will be a recommended enduser price for temporary rendering of one unit of media content. However, said enduser price is subject to variations due to means of downloading facilities, local or national networks, memory capacity of the terminal and not the least how long time the media content unit is made available to the enduser.

- Prepayment, e.g. POT system. The enduser pays a lumpsum for a predefined maximal access time to media content databases on a temporary basis, e.g. virtual juke box. The price for each download may vary according to the means of downloading, e.g. temporary storing on a terminal memory or streaming via a rendering device without any intermediate storing in the enduser terminal. -

Debiting via mobile telephone or credit card bill

- Local billing, e.g. debiting via a barcode located within the area of a local dealer or distributor. The media content is thereby downloaded and as a consequence the enduser account is debited, e.g. telephone, or credit card account.

There is a license for individuals, connecting to a local or a national network. The licence consists of an account ID, e.g. SIM card or other card or code. The other type of licence is the distributor licence, reselling licencies to his own customers, debiting them via its own billing system, e.g. via bus tickets etc. The function for licence administration, 67.

Embodiment 1, wireless or virtual jukebox.

Today there is systems for e-commerce of CD records. The systems require a fixed connected computer which implies that CD records are ordered fysically or through a personal virtual bank of music (CD records) which is gradually built up by the user on the own personal computer or at a personal part of a common central database. To build up a personal Cd record database and to download music to portable music players is relatively time consuming and requires some planning.

The so called pirate copying over internet is today a big problem for the music industry. An alternative or a compromise should be

appreciated both by representants for the music industry and by the consumers.

Conceptual description of the service (Fig. 1 and 2).

5 Personal wireless interactive access and highspeed downloading of highquality multimedia from multi database systems via terminals or devices, spontaneously and "on the spot". The consumer experience that he she has got eternal access to media content where-ever he she is, whenever he she prefers. It is important to make the service
10 simple and robust, where a complicated logon- and adressing procedure is avoided. The application is built on the feeling "here and now" and reduces the importance of everything but the pleasure of the content, the music. The cost and the effort to perform and to repeat the order and the downloading of the selected media content should be minimal. The consumer buys a licence card and pays thereby a fixed
15 price for a limited time of temporary access to a number of music content positions. This service gives the consumer a chans to listen to new music at a low rate, without having an obligation to buy music at considerably higher, normal rates. The downloaded positions
20 remains in the terminal and its memory or is streamed via the terminal or the rendering device during a limited period of time, and are thereafter automatically erased from the said memory. The music content can not be copied or transferred to other unauthorized media or equipment. The advantage is that the pirate copying is minimized
25 and that the prices can be kept at a substantially low level.

The service is marketed and licensed as a complete subscription service, that permits the right to download maximum time, max_tim and or maximum number, max_num music positions. There will be a room for
30 differentialization of services in relation to which kind of access that is utilized and what is included in the license package. Tjänsten marknadsförs och licensieras som en komplett A license package may also include hardware, e.g. a terminal.

The intention is to establish sales channels that are not normally related to data- or telecom, in order to attract as many customers as possible. The marketing focus on the content, easy access to highquality music. The record companies may also take advantage of the concept for launch of new artists and new music, so called bubbles. The service may also serve as a trustworthy instrument for statistics measurements, for investments in new artists and trends. A further advantage is that the proposed service is considered as a complement to existing markets. It will contribute to an improved consumer view on copyright rules, given that the record companies considers the new service as an opportunity to decrease the price level substantially in relation to existing products and services, with reference to the proposed new service comprising the concept of the present invention. The terminal or its account ID, e.g. SIM card ID or similar, serves as a key to dedicated content.

Description of a principal flow from an enduser perspective;

Example_1; use case based on a terminal A user (in some applications terminal A may be replaced by a server C, e.g. in a car). Ordering, reception storing and rendering of a media content data file is reflected;

Automatic logon, identification and autentification of terminal A. using a prepaid licence. Execution of limited use criterias rules.

- Downloading to terminal A, automatically via nearest server C, of table of content inidcating ID for each music position.
- Ordering of selected music position is made via a central server C1 or a local server C2. The most costeffective routing is automatically selected by the system. The principal selection criterias are radio coverage and data rate.
- Downloading and reception of said selected music positions from the selected point of downloading, server C1 or server .C2, preferrably selected by the system based on the following criterias, radio coverage, data rate and prices of media content.
- Identification and

Embodiment 4.

A mobile terminal is utilized to order, receive, store, convert TCP/IP based media content via a multi interface connector and render said media content in a television set, video screen in a car, or
5 virtual video data glasses. The services is up to copyright rules. The enduser downloads a video via a fast interface into the mobile memory adapter. The video files comprises limited use consumption restrictions, e.g. predefined period of time. After expiration of said period of time the video is erased from the adapter memory.

10

The present invention is not only restricted to the above described and at the drawings presented embodiments, but could be modified within the frame for the enclosed patent claims.

15

CLAIMS

20

1. System for distribution and rendering of media content, e.g. pieces of music, pictures, and/or text, which comprises a server (C1, C2, ...) for distribution of media content, and at least one terminal (A1, A2, ...) for ordering, reception, storing and rendering of media content, of which

25

- The server comprises a transmitter(1), a receiver (3), a processor (5), a memory (7), a software (9), and is operable for reception of an order of audio- and/or visual media content from the terminal, for ordering and reception of the said media content by means of a data file from a database (D1, D2,...), which comprises media content, and for transmission of the said content media by means of a data file to

the terminal, and

- The terminal comprises a transmitter (21), a receiver (23), a processor (25), a memory (27), a software (29) and a device (31, 32, 33, 34) for rendering of audio- and/or visual media content, and a means (34, 36) to instruct the transmitter to submit an order to the said server, where the said order refers to a selection of the said media content, and where the said receiver is adapted for reception of the said selected media content from the said server by means of a data file, and that the said rendering device is adapted for rendering of said ordered and received media content, characterized of that,

- The terminal comprises a means (29) to execute automatic deletion of or process a jam signal on the said ordered and received media content by means of a data file immediately after the expiration of a defined period of time.

- The input I/O units of the terminal are mounted together in one unit or in connection to each other via fixed or wireless interfaces.

2. System according to claim 1, wherein the terminal comprises a clock (37), that is programmed to start when the said ordered media content by means of a data file is received, and the mentioned period of time, immediately after which the said media content is erased, is predetermined and is measured with said clock.

3. System according to claim 1, wherein the terminal comprises a counter (39), that is programmed to count the times the received media content by means of a data file is rendered, and said period of time, immediately after which said media content is erased, is determined in relation to the value of the counter.

4. System according to claim 1, wherein the memory capacity of the terminal is dimensioned for a specific quantity of media content, and the said period of time, immediately after which the said media

content is erased, is determined in relation to the memory capacity of the terminal and the number of ordered and received media content after that the said selected media content is received.

5 5. System according to any of the claims 1-4, wherein the terminal is adapted with a protection (41) against illegal copying of the said received media content.

10 6. System according to claims 1-5, wherein the said protection against illegal copying of the said received media content comprises a seal of the terminal, at which the terminal memory or part thereof is erased, or at which the terminal or part thereof becomes obsolete in the case of breaking said seal.

15 7. System according to claims 1-6, wherein the terminal and/or the rendering device (31, 32, 33, 34) comprises a sealed combined component for conversion of a media content file from digital to analogue mode.

20 8. System according to any of the claims 1-7, wherein said rendering device (31, 32, 33, 34) and the ordering device (34,36) respectively is exchangeably connected to the terminal processor via connectors (35a-b), or via an air interface (78), or via an electro-mechanical interface (71), or via an optical interface (88), at which the rendering device and the ordering device respectively is provided with means to independently verify its respective identities for the terminal processor, preferrably via a handshaking procedure.

25 9. System according to claims 1-8, wherein said terminal comprises a module (72), e.g. microprocessor, for encrypted communication between a server and a terminal and for verification of the terminal identity, API, media content data, I/O ports, memory and other characteristics.

30 10. System according to any of the claims 1-9, wherein verification of terminal identity, limited use rules and restrictions is.

implemented by means of a SIM card and or a smart card solution or other memory carriers.

5 11. System according to any of the claims 1-10, wherein the server and the terminal are operable to communicate with each other utilizing at least one network or standard from the group fixed or wireless respectively in order to optimize the transmission; e.g. ISDN, PSTN, ADSL, ATM, optical fibers etc, GSM, Mobitex/PMD8000, GPRS, DAB, DVB, UMTS, W-LAN, Hyper-LAN, DECT, Bluetooth, IrDA, WCDMA, 10 WCDMA2000, IP packet switched networks, satellite based systems, shortrange radio, portable media/memory, electro-mechanical systems, optical transmission systems etc at which the communication is preferably asymmetric, with a narrowband uplink in the direction terminal-to-server and a broadband downlink in the direction server-to-terminal.

15 12. System according to any of the claims 1-11, wherein a plurality of the said terminal is compriced, and that the server is adapted to save orders of a particular media content during a period of time, and in the case that a specified number of orders have been submitted 20 of the said particular media content, broadcast the said particular media content utilizing a technique for broadcasting, in particular DAB or DVB, and as an alternative via other standards and technologies according to the claims 10 and 11.

25 13. System according to any of the requirements 1-12, wherein a server comprices a sealed combined component adapted to convert a media content file from digital to analogue mode and to transmit said media content, utilizing hopping frequencies, to a rendering device (31,33), via air, optical, or electromechanical interface.

30 14. System according to any of the claims 1-13, at which the system comprices a payment module for debiting of ordered media content, in particular prepayment with deduction at transfer of ordered content media to the terminal, and a system for administration and control of

user accounts, subscriber information, and orders and downloads respectively to the terminal.

15. System according to the claims 1-14, wherein a server and a terminal comprises an algorithm for geographical positioning service.

5 16. System according to the claims 1-15, wherein a terminal comprises a rendering device for video and interactive games.

10 17. System according to any of the claims 1-16, wherein a terminal is adapted, by means of a browser, to optimize search for best possible network regarding radiocoverage, transmission rate, and network charges.

18. Terminal for ordering, reception, storing and rendering of media content comprising;

15 - a transmitter (21), a receiver (23), a processor (25), a memory (27), a software (29) and a means for rendering and transmission respectively (31,32,33,34,35) for rendering and transmission of an audio- and or visual media content, and

- a means (36) to instruct a transmitter to submit an order to a server, wherein said order comprises a selection of said media content,

20 - at which said receiver is adapted for reception of said selected media content from said server by means of a data file,

- and said rendering device is adapted for rendering or transmission of said ordered and received media content,

c h a r a c t e r i z e d of that it comprises;

25 - a means for automatic deletion or jamming of said ordered and received media content by means of a data file immediately after the expiration of a predefined limited period of time.

19. Terminal according to claim 18, of which said terminal comprises a clock (37), that is programmed to start upon reception of said ordered media content, by means of a data file, and said period of time, immediately after which said media content is erased or jammed, is predefined and measured with said clock.

20. Terminal according to claim 18, of which said terminal comprises a counter (39), which is programmed to count the times that said received media content by means of a data file is rendered, and said period of time, immediately after which said media content is erased or jammed, is determined in relation to the value of the counter.

21. Terminal according to claim 18, of which the memory of said terminal has a capacity for a defined quantity of media content, and said period of time, immediately after which said media content is erased or jammed, is predefined in relation to the capacity of the terminal memory and the quantity of ordered and received media content after that said selected media content is received.

22. Terminal according to any of the claims 18-21, at which a protection against unauthorized copying, of said received media content, is adapted.

23. Terminal according to claim 22, at which said protection against unauthorized copying of said received media content comprises a seal of the memory by means of an electronic circuit (40), which is adapted to the terminal memory or parts thereof, and said media content by means of a datafile is erased if said seal is broken, e.g. disconnection or removal of memory.

24. Terminal according to any of the claims 18-23, at which said rendering device is exchangeably connected to the terminal processor via connectors (35a-b) or via an air interface, wherein the said rendering device is exchangeably connected to a terminal processor by means of connectors (35a-b) or via an air interface, at which the rendering device is provided with a means to verify its identity for

said terminal processor, e.g. a handshaking procedure.

25. Terminal according to claims 18-24, at which a rendering device comprises a module (72), e.g. microprocessor, for encrypted communication between said terminal and said rendering device, and for verification of said rendering device identity, API, media content data, I/O ports, memory and other characteristics.

26. Terminal according to any of the claims 18-25, of which said terminal is a handheld, mobile unit, and said transmitter is adapted to submit an order to the server and said receiver is adapted for reception of said selected media content via at least one air interface, preferably a radio interface.

27. Terminal according to any of the claims 18-26, which comprises a sealed combined module for conversion of said media content data file from digital to analogue mode.

28. Terminal according to the claim 18-27, at which said rendering device (33), comprises ear-phones, wherein a sealed combined module converts a digital signal to analogue mode and said module comprises a membrane to produce a sound close to the membrane of a human ear.

29. Terminal according to any of the claims 18-28, at which a rendering device (33) and an ordering device (36) comprises a headset and or virtual data video glasses.

30. Terminal according to any of the claims 18-29, wherein limited use rules and restrictions is implemented by means of a SIM card and or smart card.

31. Terminal according to any of the claims 18-30, whereof said terminal utilizes IP addressing.

32. Terminal according to any of the claims 18-31, at which a media content is transmitted from a server to a rendering device (33) by means of a mobile memory adapter, e.g. utilizing protocols for

conversion of IP based media content to video format.

33. Utilization of a server for distribution of a plurality of media content, e.g. pieces of music, pictures and/or text, in combination with a terminal according any of the claims 18-32.

5 34. Procedure for ordering, reception, storing, and rendering of a media content, c h a r a c t e r i z e d of that;

10 - an order is submitted to a server for distribution of a plurality of media content, e.g. piece of music, picture and/or text, of which the said order comprices a selection of the said plurality of media content,

- a selected media content is identified and validated before it is approved for import to the server.

15 - a selected media content by means of a datafile, which is encapsulated in a data transmission format that may comprice various media content formats, encryption codes and keys, limited use riterias, etc

- a selected media content by means of a datafile, which comprices a code for identification of and authorization of a terminal and or rendering device.

20 - said selected media content by means of a data file initiates, and executes terminal specific limited use criterias and user rules, e.g. identification and categorization of limited use or timestamped files, b e f o r e rendering or any other functions are initiated.

25 - a selected media content by means of a datafile, which is automatically erased or jammed immediately after expiration of a predefined limited period of time.

35. Procedure according to claim 34, in which a clock (37) is started when said ordered media content by means of a data file is received,

and said period of time, immediately after which said media content is erased, is predefined and measured with said clock.

36. Procedure according to claim 34, in which the times, said received media content by means of a data file is rendered, and said period of time, immediately after which said media content is erased, is predefined in relation to said value of the counter.

37. Procedure according to claim 34, in which said received media content is stored in a memory, that has a capacity for a defined quantity of media content, and said period of time, immediately after which said media content is erased, is determined in relation to the capacity of the memory and the quantity of media content that is ordered and received after that the said media content is received.

38. Procedure according to claim 34, in which the value of the counter is determined in relation to the number of conversions of the said datafile as from digital to analogue mode and reception of said media content from the server to the terminal is interrupted in case of non-receipt of terminal characteristics and debiting information.

39. Procedure according to any of the claims 33-38, in which said received media content is located in the memory of a terminal, wherein authorized said media content datafiles are separated from non-authorized datafiles.

40. Procedure according to any of the claims 33-39, in which copying of said received media content data file is barred.

41. Procedure according to any of the claims 33-40, in which said received selection of media content is erased from the terminal memory of the terminal upon removal or disconnection of the said memory.

42. Procedure according to any of the claims 33-41, in which a media content by means of a data file comprises a code for verification of

the terminal account ID for initialization of debiting.

43. Procedure according to any of the claims 33-42, in which data and information related to the ordering procedure and characteristics of media content is visualized by means of a matrix on a rendering display, screen or virtual video glasses, e.g. ID, text, pictures etc.

44. Procedure according to any of the claims 34-43, in which ordering of media content is performed by means of voice recognition.

45. Procedure according to any of the claims 33-44, in which a media content by means of a data file has a unique ID related to a specific terminal, device, portable media or memory, and said content media is accessible for identification in the server or in the terminal.

46. Procedure according to any of the claims 33-43, in which identification and ordering of media content is performed by means of optical readers, pens, bar- or dot- codes (42).

47. Procedure according to any of the claims 33-46, in which media content data files comprises information fields to serve as a base for checking and production of statistics for debiting purposes.

48. Procedure according to any of the claims 33-48, in which a terminal submits a checking record to a server each time a terminal is logged in to the system, and a control is performed of registered order submissions of selected media content and predefined time parameters for said selected media content in a server versus the registered quantities and times of registered digital analogue conversions in the terminal.

49. Software program loadable in the internal memory of a terminal for ordering, reception, storing, and rendering of a media content, comprising software code to perform a procedure according to any of the claims 33-49 at which said software is executed in said terminal.

50. Software program loadable in the internal memory according to

claim 49, in which upgrades are performed automatically in connection to ordering of media content.

1/6

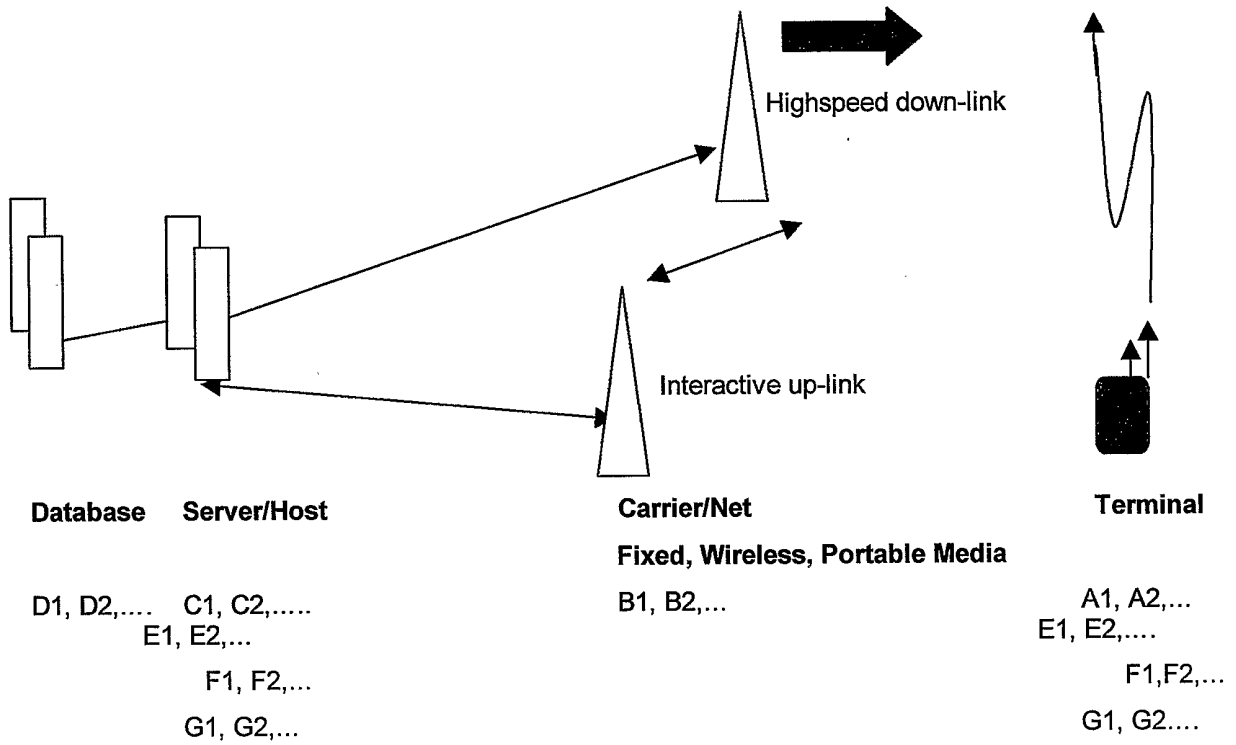

Fig. 1

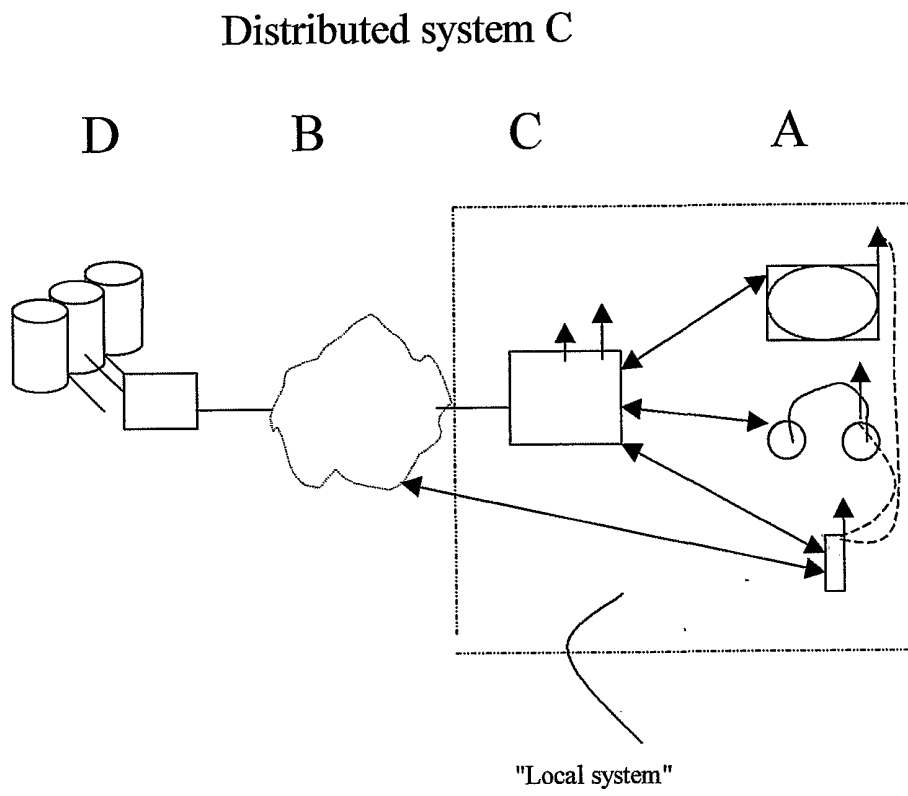

Fig. 2

3/6

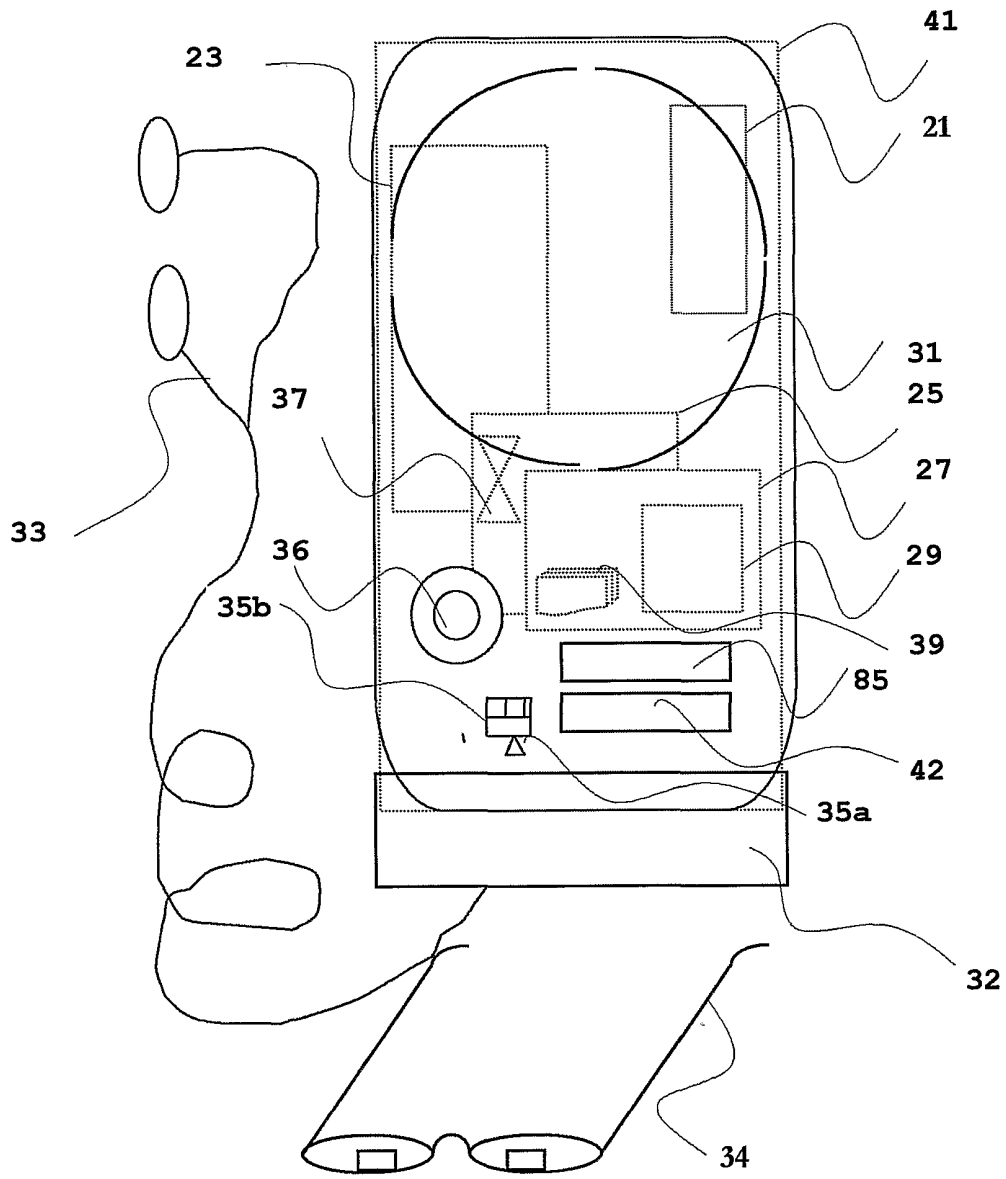

Fig. 3

4/6

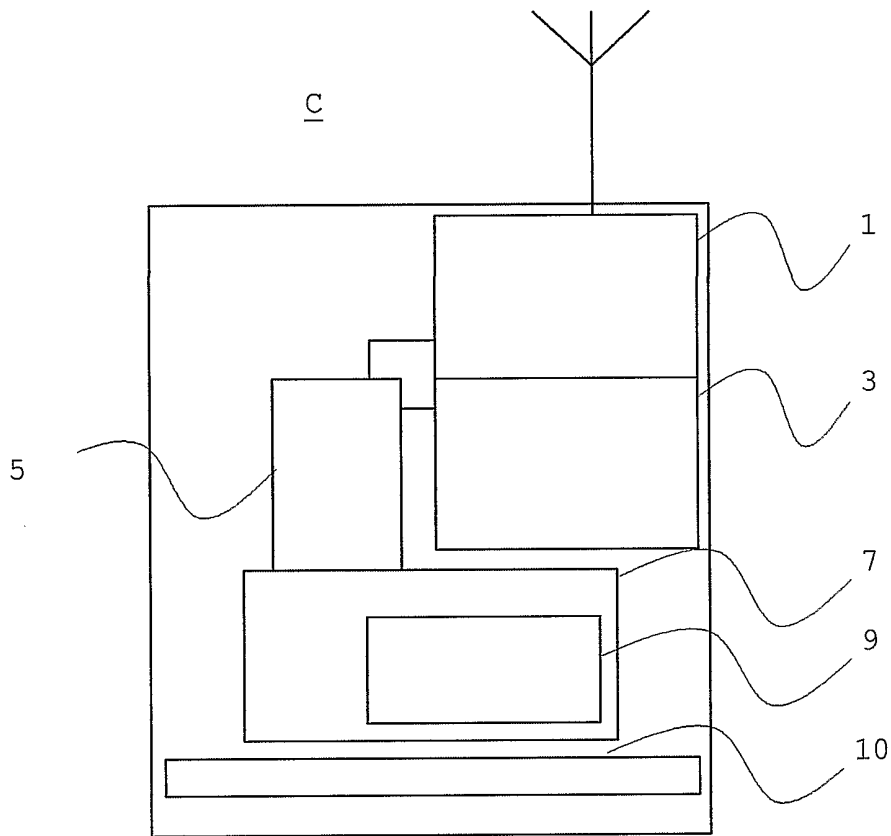

Fig. 4

5/6

G module; limited right of consumption, functional reference model.

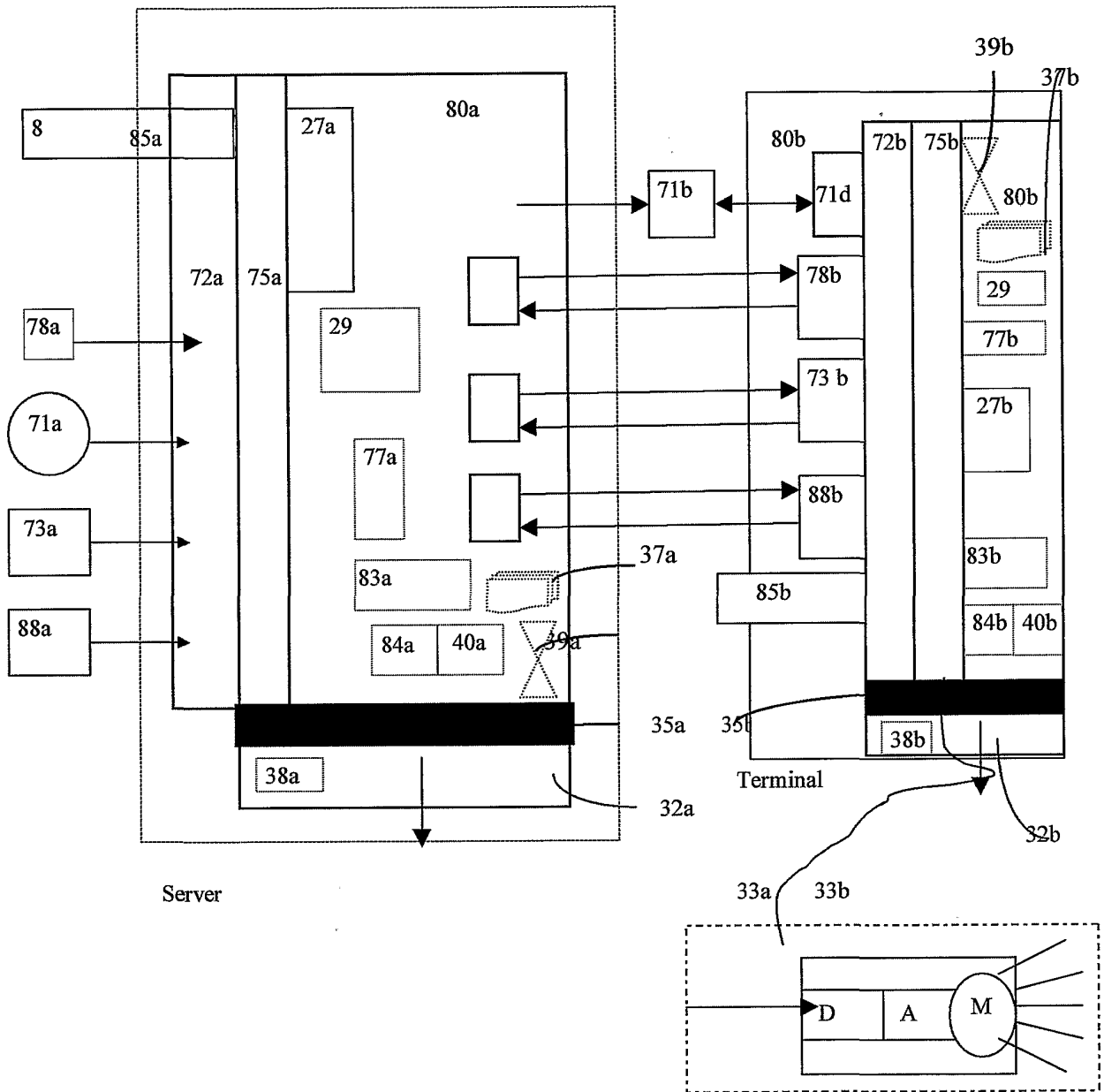

Fig. 5

6/6

Example

of a structure for module G (LUC).

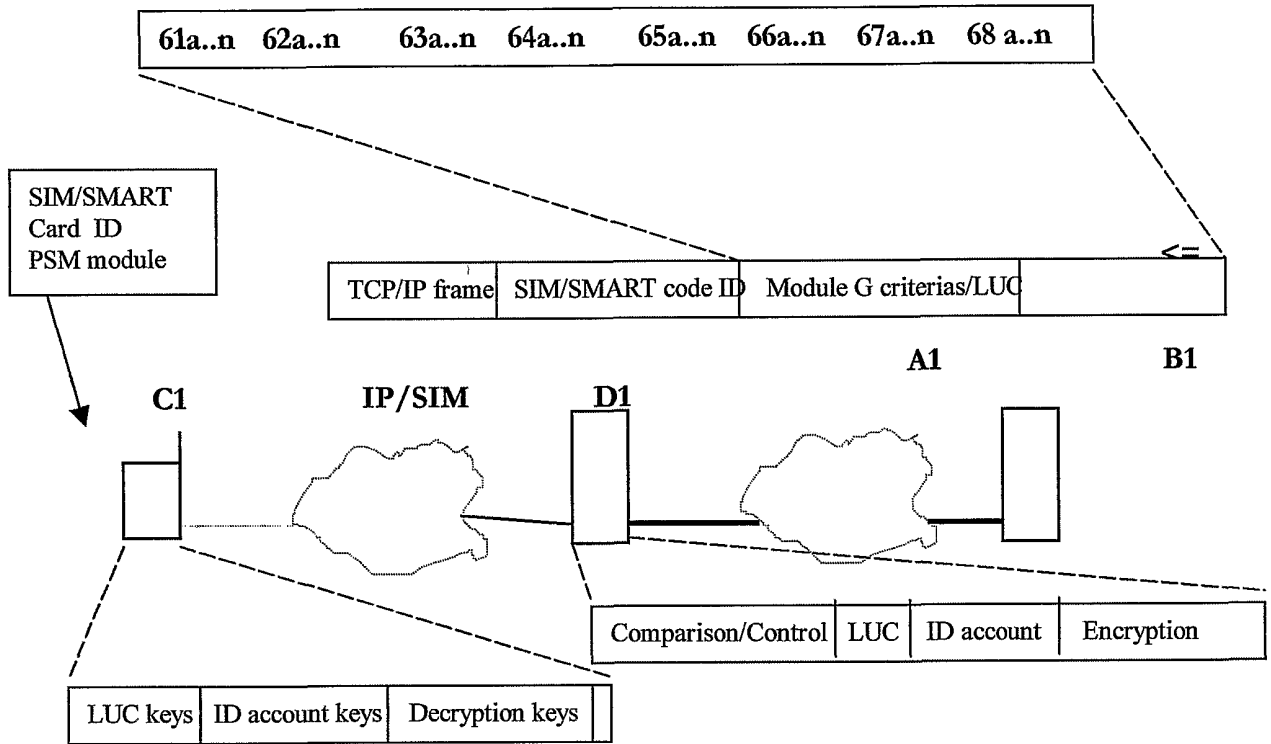

Fig. 6

INTERNATIONAL SEARCH REPORT

International application No.

PCT/SE 01/01739

A. CLASSIFICATION OF SUBJECT MATTER		
IPC7: G06F 1/00 According to International Patent Classification (IPC) or to both national classification and IPC		
B. FIELDS SEARCHED		
Minimum documentation searched (classification system followed by classification symbols)		
IPC7: G06F		
Documentation searched other than minimum documentation to the extent that such documents are included in the fields searched		
SE,DK,FI,NO classes as above		
Electronic data base consulted during the international search (name of data base and, where practicable, search terms used)		
WPI DATA, EPO-INTERNAL		
C. DOCUMENTS CONSIDERED TO BE RELEVANT		
Category*	Citation of document, with indication, where appropriate, of the relevant passages	Relevant to claim No.
A	EP 0315426 A2 (XEROX CORPORATION), 10 May 1989 (10.05.89), claim 1 --	1-50
A	US 5822771 A (AKIYAMA,R. ET AL.), 13 October 1998 (13.10.98), abstract --	2,3,20,21, 33,34
A	US 4740890 A (WILLIAM,T.), 26 April 1988 (26.04.88), column 1, line 57 - column 2, line 5 --	1-50
A	US 5588146 A (LEROUX,J.-Y.), 24 December 1996 (24.12.96) -- -----	1-50
<input type="checkbox"/> Further documents are listed in the continuation of Box C. <input checked="" type="checkbox"/> See patent family annex.		
* Special categories of cited documents: "A" document defining the general state of the art which is not considered to be of particular relevance "E" earlier application or patent but published on or after the international filing date "L" document which may throw doubts on priority claim(s) or which is cited to establish the publication date of another citation or other special reason (as specified) "O" document referring to an oral disclosure, use, exhibition or other means "P" document published prior to the international filing date but later than the priority date claimed "I" later document published after the international filing date or priority date and not in conflict with the application but cited to understand the principle or theory underlying the invention "X" document of particular relevance: the claimed invention cannot be considered novel or cannot be considered to involve an inventive step when the document is taken alone "Y" document of particular relevance: the claimed invention cannot be considered to involve an inventive step when the document is combined with one or more other such documents, such combination being obvious to a person skilled in the art "&" document member of the same patent family		
Date of the actual completion of the international search		Date of mailing of the international search report
30 October 2001		27-11-2001
Name and mailing address of the ISA/ Swedish Patent Office Box 5055, S-102 42 STOCKHOLM Facsimile No. +46 8 666 02 86		Authorized officer Jesper Bergstrand/LR Telephone No. +46 8 782 25 00

INTERNATIONAL SEARCH REPORT

Information on patent family members

International application No.

PCT/SE 01/01739

Patent document cited in search report			Publication date	Patent family member(s)		Publication date
EP	0315426	A2	10/05/89	DE	3855152 D,T	02/10/96
				JP	1156840 A	20/06/89
				JP	2795856 B	10/09/98
				US	4914586 A	03/04/90
US	5822771	A	13/10/98	JP	6324858 A	25/11/94
				US	6067640 A	23/05/00
US	4740890	A	26/04/88	NONE		
US	5588146	A	24/12/96	EP	0594493 A	27/04/94
				FR	2697357 A,B	29/04/94
				JP	6332717 A	02/12/94
				SG	48122 A	17/04/98