

Jan. 28, 1969

J. M. WOLF

3,425,006

CAVITY RESONATOR WITH MODE DISCRIMINATING MEANS

Filed Feb. 1, 1967

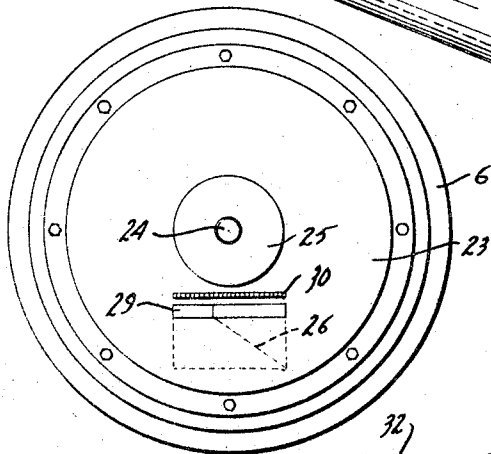
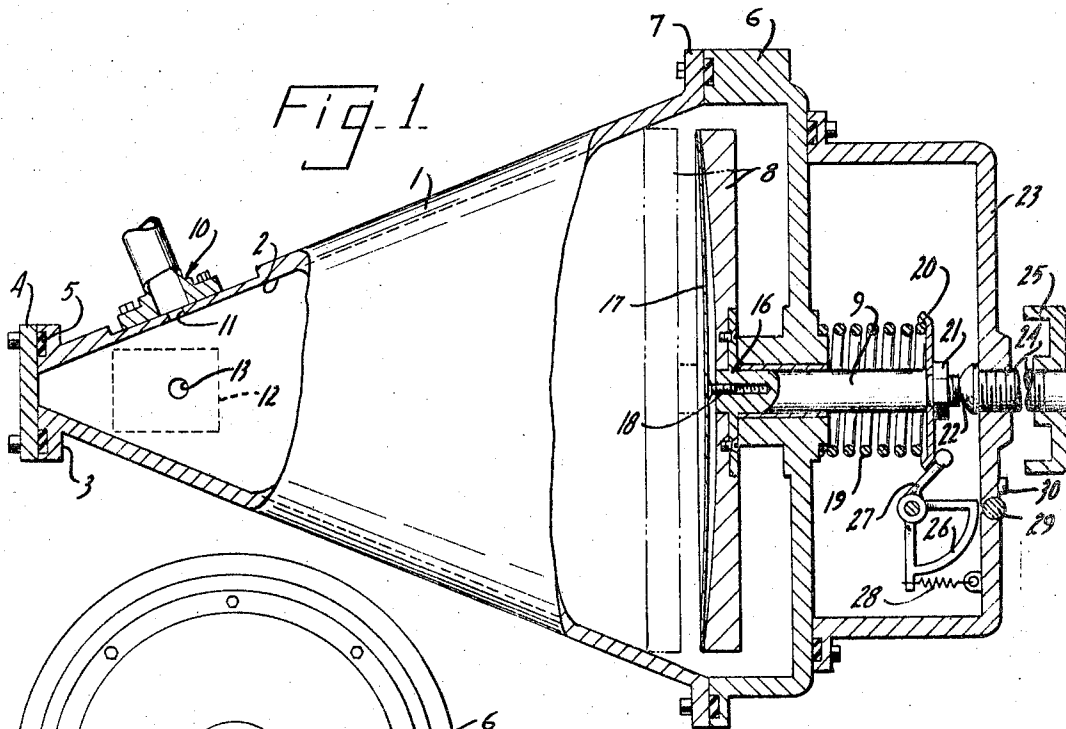

Fig. 2.

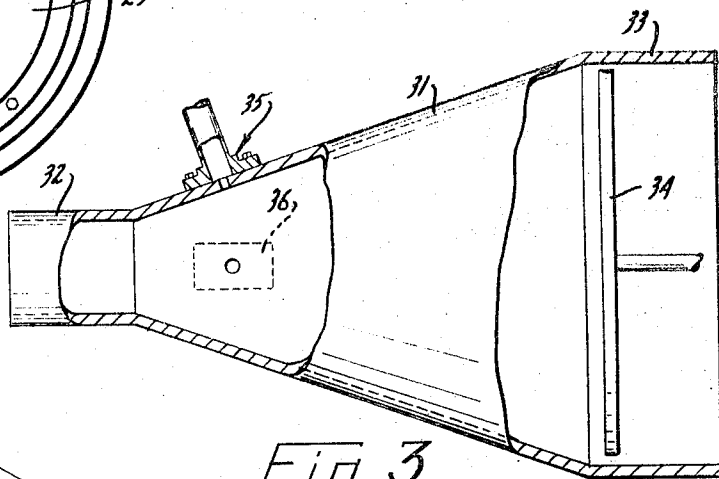

Fig. 3.

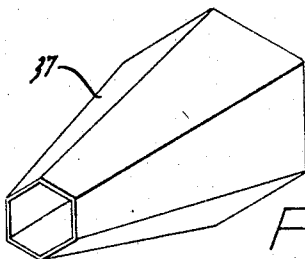

Fig. 4.

INVENTOR
JAMES M. WOLF
BY Andrew F. Starke
Attorneys

1

2

3,425,006

**CAVITY RESONATOR WITH MODE
DISCRIMINATING MEANS**

James M. Wolf, Ann Arbor, Mich., assignor to Johnson Service Company, Milwaukee, Wis., a corporation of Wisconsin

Filed Feb. 1, 1967, Ser. No. 613,327

U.S. Cl. 333-83

12 Claims

Int. Cl. H01p 7/06

ABSTRACT OF THE DISCLOSURE

A right circular hollow cone member is provided with a reflecting boundary plate in the large end and an energy source for introducing electromagnetic energy into the cavity. The electromagnetic energy source is located at a limiting cross-section of the cone member which serves as the reflecting boundary. The plate includes an adjustable curved surface of a spherical segment.

This invention relates to a microwave cavity resonator and particularly to a cavity resonator having means to substantially eliminate the effects of undesired modes of resonance while permitting tuning of the cavity over a relatively substantial range for a desired mode.

A cavity resonator is a well known device which has been employed as an echo box, wave meter, frequency stabilizing cavity, and the like. A cavity resonator is a volume having substantially closed conducting walls. The internal surface is preferably highly electrically conductive such that the flow of current is essentially confined to an exceedingly thin layer of metal on the inner surface of the cavity to substantially minimize electrical losses. Often the shape of the cavity is a right cylinder or the like as the manner in which such cavities resonate in response to electromagnetic energy supplied thereto are more easily calculable. The analysis of cavity resonators having boundaries in the form of a right circular cylinder has been presented in United States Patent 2,541,925 which issued Feb. 13, 1951, to J. P. Kinzer.

The modes of electromagnetic oscillation within right cylindrical cavities are generally described as transverse electric (TE_{lmn}) or transverse magnetic (TM_{lmn}) with the subscripts l, m, n identifying the particular current and field patterns of the respective modes. Generally, the first subscript number indicates the number of full cycles of the field encountered in traversing the circumference of a circular cross-section of the cavity. The second subscript number indicates the number of half waves encountered in traversing a radius from the center of the cylinder to the outer wall. The third subscript number indicates the number of half waves encountered in traversing the cavity in the axial direction.

The TE_{01n} modes are highly desirable for tunable high-Q resonators because they do not require current crossing between the outer wall and the circular end plates of the cavity, and because the Q factor is high. These particular modes have therefore found wide application.

Generally, a cavity resonator is selected to operate with a particular mode of resonance and within a predetermined frequency band. However, any such cavity resonator will have a large number of natural resonances including the desired mode and a substantial number of undesired modes. The resonant frequencies of these depend on the resonator dimensions.

These undesired modes of resonance seriously limit the application of cavities as practical resonators, particularly as tunable resonators and at the higher microwave frequencies. Not only may an undesired resonance be en-

countered, but the cavity may become resonant simultaneously in two modes at the same cavity dimensions and at the same or nearly the same frequency. This may have the effect of seriously increasing the loss in the desired mode. Such simultaneous resonances are identified as "mode crossings" referring to points of intersection of the lines representing the modes on the graphical field known as the "mode chart" disclosed by the previously referred to Kinzer patent. At such a point of double resonance the mode lines may not actually cross when observed in experiment, but each of the "crossing" modes may merge electrically into the other due to coupling.

Four generic conceptual methods for avoiding undesired resonances and mode crossings or their effects are:

(1) Combinations of input frequencies and cavity dimensions which prevent them. This may include selectively perturbing an undesired mode to move it away from the desired mode;

(2) Avoiding coupling between the desired mode and the undesired modes;

(3) Avoiding excitation of the undesired modes from the input and/or output structures; and

(4) Selectively loading the undesired mode with resistance.

The present invention is particularly directed to a new and unique structure for avoiding such undesired resonances and mode crossings and bears on methods of avoiding excitation and of selectively loading the undesired modes.

Before describing the present invention, several approaches of the prior art to the above generic concepts are briefly described.

As an example of the first method, Kinzer Patent 2,541,925 suggests that the frequency band and tuning range of a right cylinder be selected to include only the desired mode, in order to eliminate the undesired modes. This obviously substantially restricts the extent of the frequency band over which the cavity can be tuned.

United States Patent 2,439,388 which issued to Hansen on Apr. 13, 1948 suggests introduction of metallic structures to prevent undesired modes. The actual effect would be to selectively perturb the undesired mode. Similarly, "strapping" has been introduced into magnetron cavities to compel resonance in the desired mode. The actual effect is to perturb the undesired modes. Perturbation of the undesired companion modes of the TE_{01n} in the echo boxes, by the use of concave end plates in a right cylindrical cavity, has been suggested in the Baños Patent 2,600,186 which issued June 10, 1952.

The W. F. Kannenberg Patent 2,460,909 which issued Jan. 25, 1949 discloses a means for avoiding mode crossings in a cavity resonator by employing a slightly tapered frusto-conical cavity boundary having parallel end plates one of which is moved relative to the other to change the cavity dimensions and therefore the frequency. Additionally, means are provided for simultaneously moving the end plates relative to the cavity wall. The latter movement permits varying the effective diameter as the length is varied, and therefore permits the ratio of diameter to length of the resonator to be kept constant during tuning. By analogy to a right cylindrical resonator it can be anticipated that operating at a fixed diameter to length ratio should permit operation at a fixed point on the mode chart even though the resonator is tuned. If this fixed point is not chosen at a mode crossing, the tuning range should be free of mode crossings.

In this latter form of resonator there is a practical difficulty in making the two plungers follow precisely, and one is forced to place the input and output coupling devices on a tuning plunger as the side wall moves. This excites the TM family of modes which is, in general, most undesirable.

As an example of the second method and as suggested in the Baños Patent 2,600,186, maintaining exact parallelism between the ends of a right cylindrical cavity avoids coupling between the TE_{01} family of modes and the TM_{11} family resonant at the same cavity configuration and frequency.

As an example of the third method or concept, the prior art has suggested that the input coupling device be properly located to minimize excitation of undesired modes. Thus, if the input coupling is only to the longitudinal magnetic field, the entire family of TM modes is suppressed. Also, excitation at a nodal point of an undesired mode may prevent excitation of that mode.

As an example of the fourth method, absorbing material has been placed in the back cavity of a right cylindrical echo box; air gaps filled with absorbing material have been provided in the end plates or the side walls of the resonators; or resistive materials have been introduced at points of low field of the desired modes, as in the gap around the plunger in the TE_{01n} modes.

The present invention is directed to a highly improved tunable resonant cavity which employs new structures to restrict the resonances primarily to the desired modes, and to suppress the undesired modes. The means which are used to accomplish this function can be related to the four generic concepts discussed above. To produce a cavity which would be free from mode crossings, without restricting the tuning range severely, a cavity is constructed which can be made to shrink or grow as desired. By the principle of similitude, treated in standard works on the subject, it follows that the resonant wave lengths in each and every mode shrink or grow in proportion to the cavity size as well. Thus, there should be no mode crossings. The previously cited Kannenberg patent uses this principle, but the resulting structure presents some practical problems, as previously discussed.

In accordance with the present invention, the cavity is defined by a pyramidal or conical cavity body portion or member having a generally loose fitting and axially movable base or end wall plunger. The pyramidal member is made as a right cone and by analogy to right cylindrical cavities, no current is required across the loose joint to the base. The inventor has found that cavities of this form have excellent properties, although a number of reasons for doubting this were present prior to experimental trial.

Since the attenuation of wave-guide becomes infinite as the diameter goes to cut-off, one would anticipate that the Q factor of cavities of this form might be low. This is not the case experimentally.

One might doubt that substantial tuning could be attained with a cavity of this form, since the gap around the tuning plunger becomes large, in terms of a fraction of the free-space wave-length. Experimentally, it has been observed that a substantial loss in Q is not noted until the gap around the plunger exceeds ten percent of the plunger radius. Since this takes place when the cavity is large and the Q is consequently high, it will generally be acceptable. Further, since the wave-guide wave-length in the large end of the cavity is approximately that in free-space, it would be acceptable to replace the cone at that point with a simple cylinder for which there would not be a large gap.

The growing gap is an element of the resonator cavity that does not scale and consequently there might be some mode crossings. The cavity dimensions chosen are preferably tested by experiment to avoid configurations with mode crossings. Mode crossings take place very gradually, however.

Right cylindrical cavity resonators can be considered as sections of a cylindrical wave-guide terminated at both ends in short circuits representing the end plates. Such a model predicts the resonances satisfactorily with the exception of the TM_{1m0} modes. When the cavity has a length equal to an integral multiple of a half wave-guide wave-length, a resonance will be found. This approach can be extended to the full pyramidal cavity of this in-

vention. While a uniformly tapered wave-guide is not without reflection, it appears that this reflection sums to nearly zero every half wave-length, which is just where the resonances take place. It has been found possible to predict the resonances approximately by defining a phase shift per unit length as $2\pi/\lambda g$, where λg is given by the usual formula for circular wave-guides of diameter D, but where D and hence λg vary along the cone. If this phase shift is integrated from the location of the cut-off diameter to the position of the plunger or movable end wall, resonances will be found when the integral has values of $n\pi$.

The extreme vertex of the pyramidal cone is a more or less indifferent region, since the attenuation for all wave-guide modes in reaching this point is very high. It is thus possible to cut off the tip of the cone without changing the behavior of the cavity. This is convenient for fabrication of the cavity.

A further element of the cavity design having to do with mode perturbation is discussed in connection with the base construction.

In accordance with a further feature of this invention, more particularly related to the third concept, the input and output coupling structures are located at a point of small diameter on the cavity body portions. This avoids exciting the higher wave-guide modes from the input. This is a matter of importance, since the number of modes that can be supported in the large end of the cavity is great. The full conical configuration of the cavity permits the placements of coupling devices on the side wall. This permits the suppression of the TM family of modes at the input. Orifice coupling from a rectangular wave-guide has been employed, though other types could be used.

The present invention, for optimum results, employs a base in the form of a segment of a spherical surface about the vertex of the cone to obtain benefits of the second concept. The naturally conforming reflecting end for a conical wave-guide is such a sphere, just as the conforming end for a cylindrical wave-guide is a flat plate. It is believed that the reason that the spherical end is superior is that fewer higher order modes need be excited in reflection from such an end than from a flat end, or that the degree of such excitation is less. It is further believed that higher order modes can be excited in the large end of the resonator which are undetectable through the input and output structures located at the small end, where these modes are below cut-off. They are however, detectable in that such coupling between modes may cause a reduction in the Q factor of the desired mode.

Since the curvature of the end plate cannot be altered as the resonator is tuned, the curvature of this end plate is also a factor which does not scale during the tuning of the cavity. It thus will cause slight perturbation of the modes. It appears to be possible to employ this perturbation to offset the effects of the perturbation due to the gap around the plunger, which also varies during tuning. This generally requires empirical adjustment of the plunger radius of curvature until the Q factor remains good over the tuning range.

As a feature of the third concept, an absorber is provided in the back cavity, behind the plunger or base plate and around the rim of the base plate. Successful use has also been made in experiment of grooves made in the face of the plate and partially filled with absorbing material.

A particularly interesting location for absorbing elements to suppress those modes lower than the desired mode is afforded by the conical construction. The induction field of these lower modes extends farther into the tip of the cone than does the induction field of the desired mode. It is thus possible to place resistive material in the tip of the cavity, well beyond the point of cut-off of the desired mode, and selectively load the lower undesired mode. It has been found possible to shape the resistive material to conform to the direction of the electrical field of particular modes that it is desired to suppress to make the loading still more selective.

5

The tip of the cone being more or less an indifferent region, the exact conical shape need not be preserved. Tests of selective loading in a region beyond cut-off were successfully made in a right cylindrical cavity having an axial cylinder extending beyond the end plate, in substantially the fashion of the tip of the cone. The shaping of this portion beyond cut-off can also be employed for selective perturbation.

The present invention thus provides a relatively simple, reliable resonator structure for essentially eliminating undesired modes through the means of selectively loading of the undesired lower modes and of preventing coupling to undesirable higher modes.

The drawing furnished herewith illustrates preferred embodiments of the present invention in which the above advantages and features are disclosed as well as others which will be clear to those skilled in the art.

In the drawing:

FIG. 1 is a side elevational view of resonant cavity with the end portions broken away and sectioned to show a construction in accordance with the present invention;

FIG. 2 is a reduced end elevational view of the cavity unit shown in FIG. 1;

FIG. 3 is a diagrammatic illustration of an alternative embodiment of the cavity configuration; and

FIG. 4 is a pictorial view showing a further cavity side wall configuration within the present invention.

Referring to FIG. 1, the present invention is illustrated in connection with a tunable cavity resonator, shown suitably as an echo box. In FIG. 1, the end portions are broken away to a vertical section through a center axis of general cavity symmetry about which an enclosing side wall 1 is symmetrically formed. The side wall 1 is a truncated cone formed of any suitable supporting material and having an inner highly conductive layer 2, such as silver. The small or vertex end of the side wall 1 is provided with an outer flange 3 to which a closure plate 4 is bolted or otherwise secured with a sealing gasket 5 disposed therebetween. The opposite or large end of the side wall 1 is closed by a cap 6 similarly bolted to the flange 7 on the large end.

A movable end plunger or wall 8 is disposed within the large end and supported for axial movement along the axis of the side wall 1 by a shaft 9 which is slidably mounted in cap 6. The inner face of plunger 8 is provided with a highly conductive surface and provides a reflecting member at the large end. Shaft 9 is coupled to a tuning control assembly to selectively axially position the wall 8 along the axis of the cavity such as to vary the effective length of the cavity for tuning purposes. An input signal coupling device 10 is mounted on the side wall near the vertex or small end in alignment with an input aperture 11. An output coupling device 12 is similarly secured to the cavity side wall 1 in circumferentially spaced alignment from the coupling device 10 and an aperture 13 is provided to transmit energy and provide an output signal.

Before describing the illustrated components in detail, the operation is briefly summarized as follows. The input coupling device 10 is excited to introduce a signal into the cavity. The aperture 11, as more fully developed hereinafter, is positioned at a diameter of the cone 1 which is insufficient to propagate the higher modes and thereby prevents transmission of such higher modes above a selected desired mode. The desired modes, as well as the lower modes, are induced into the cavity 1 and propagate toward the end wall 8 where they are reflected to the narrow end. However, in the return path, the desired mode reaches a limiting diameter spaced from the smallest end of the side wall which is insufficient to support propagation of the desired mode and consequently the desired mode is reflected and, if the cavity dimensions appropriate, will provide resonance in the desired mode. The desired mode travels at least to the output aperture to permit transfer of the desired mode as an output. On the other hand, the modes below the desired mode propagate

6

beyond the point of reflection of the desired mode, and their field is relatively more intense beyond this point than is the induction field of the desired mode. The end wall 4 may be considered to be made of electrically dissipative material, and from its location to preferentially load the undesired modes.

More particularly, in the illustrated embodiment of the invention, the input coupling device 10 and the output coupling device 12 are shown diagrammatically as wave-guide type inputs. Wave-guide devices are well known and no further description thereof is given. However, it may be noted that the devices shown are merely for purposes of illustration only and that any other suitable coupling means may be employed, for example, a coupling loop.

In connection with certain aspects of this invention, the input and the output may also be placed in the end wall 8. As previously noted, the side wall input is desired, however, to permit placement at a diameter from which undesirable higher modes will not be propagated and to avoid excitation of the TM modes.

The end cap 6, which closes the large end, is generally a cup-shaped member secured with its edge abutting the flange 7 of the side wall 1. The shaft 9 is slidably disposed within a suitable bearing in the cap 6 with the inner end secured to the back of plate 8. The inner end of shaft 9 terminates in a cap of flanged portion 16 secured to the wall 8 by suitable attachment screws. The inner face of wall 8 is concave. A thin flexible reflecting member 17 includes a mounting stud 18 which threads into an appropriately tapped opening in the shaft 9. The peripheral edge of member 17 engages the adjacent portion of wall 8. The member 17 may be provided with a slight curvature by turning of the stud 18 into the shaft 9. The precise preferred curvature of the member 17 is readily determined by operating the echo box and adjusting the curvature until optimum results are obtained.

The basic structural material of wall 8 is a suitable absorbing material such that any of the higher modes of resonance which tend to exist within the cavity behind the wall 8 are essentially absorbed.

A spring 19 encircles the outer portion of the shaft 9 and acts between the cap 6 and a retaining plate 20 which is secured to the outer end of the shaft by a suitable nut 21 threaded onto the outer end of the shaft. Spring 19 is stressed to continuously urge the wall 8 outwardly against an adjustable stop 22.

An outer panel 23 is secured to the outer surface of the cap 6 overlying the outer end of shaft 9. Stop 22 is secured to the end of a shaft 24 threadedly mounted centrally of the panel 23 in alignment with the outer end of the shaft 9. A manually operable knob 25 is secured to the outer end of the shaft 24 for manual positioning of the stop and thereby the plate 8 against the bias of the spring.

Additionally, a frequency reading dial drum 26 is pivotally mounted within the panel 23 and carries an integral angularly offset arm 27 extending into the path of the spring retaining plate 20. The dial drum 26 is loaded by a spring 28 to resiliently hold arm 27 in engagement with the retaining plate 20. The dial drum 26 therefore is pivoted past a small viewing aperture over which a glass rod magnifier 29 is secured. The face of drum 26 carries a diagonal line or field division, which appears through the magnifier 29 as an essentially vertical line. A scale 30 parallel to magnifier 29 is constructed to provide reading of the resonance setting in suitable units such as 100 megacycle increments.

The operation of the illustrated embodiment of the invention may be briefly summarized as follows.

When the input signal pulse is applied through the input wave guide 10 and the aperture 11, the desired and lower modes will be propagated toward the tuning plunger wall 8. As previously noted, the higher wave guide modes cannot generally propagate because the diameter of the cavity at the aperture 11 is insufficient to support such modes. The propagating modes are reflected by the wall

8 and travel in the reverse direction toward the vertex of the truncated conical side wall 1. The desired mode encounters the limiting or cut-off diameter beyond the aperture 13 at which the mode is reflected toward the tuning wall 8 to provide the desired resonance effect. An output signal appears at the output wave guide coupling device 12. The undesirable lower modes, however, travel further to the left along the side wall lying to the left of the waveguide coupling devices 11 and 12 in FIG. 1 closer to the end closure plate 4 which serves to absorb or dissipate the energy thereof.

The output of the desired mode appears at the output wave-guide as a relatively strong signal. A transient signal having an appreciable ring time is simultaneously returned to the external system through the input coupling device, both essentially without interference from the undesirable modes.

In essence, the small diameter portion of the side wall to the left of the aperture 11 and particularly the cut-off diameter for the desired mode defines a mode discriminator through which the lower modes pass and are dissipated.

In connection with the design of a resonant cavity in accordance with the present invention, the transition in diameter from the small to the large end is preferably made in a continuous gentle taper which is symmetrical about the axis of propagation in order to prevent generation of undesirable lower and higher modes within the cavity as a result of discontinuities in the cavity wall. The generation of the higher and/or lower modes creates a loss of energy within the cavity and thus reduces the effective ringing time of the desired mode; for example, when employed as an echo box. The truncated cone is a practical method of forming the cavity with the desired transition. In the broadest aspect, however, the cavity construction can take many other forms.

FIG. 3 is a diagrammatic illustration of a possible alternative construction. In FIG. 3, the cavity includes a truncated cone 31 having cylinders 32 and 33 extending outwardly from the opposite ends. A tuning wall 34 is mounted in the enlarged end cylinder 33 and serves to vary the cavity length. The input and the output signals are applied as in FIG. 1 by suitable input devices 35 and 36 at a diameter selected to correspond to a critical diameter for propagation of a desired mode.

In operation, the desired mode, as well as the lower mode, are established within the cavity 31. The higher modes are not noticeably generated as a result of the critical diameter selection for location of device 35. Upon reflection from wall 34, the lower modes propagate into the truncated tip of the cone 31 and the small cylinder 32 which serves as a wave-guide for transmitting of the lower modes from the cavity and dissipation by radiation. If desired, a suitable absorbing material might be provided within the cylinder 32. The truncated cone 31 and cylinder 33, together with the end wall 34 and the virtual end wall furnished by the small diameter portion of the cone 31 and waveguide 32, function to store a substantial amount of field energy within its volume.

In FIG. 3, the tuning wall 34 is positioned within the enlarged end cylinder 33 of the cavity to maintain a constant gap between the periphery of the wall 34 and the cylinder 33.

In a tapered cone, the enlargement of the gap as the tuning wall is positioned to lengthen the cavity may result in the reduction of the Q factor of the cavity at the desired mode with a resulting reduced ring time. The lower frequency portion of the band, however, is the high ring time region and a slight loss may well be accepted. If considered unacceptable, the use of the large-end cylinder provides a minimum and constant air gap. This may be considered acceptable because for the lower frequencies the wave-guide wave-length is almost identical to the free-space wave-length so that the diameter variation has negligible effect on the ring time.

The invention has been generally described in connec-

tion with a cone. However, pyramidal body members having a cross-section other than a cone may be employed. For example, a pyramidal body member 37 having a hexagonal cross-section, as shown in FIG. 4, may be employed. As used in the present description and claims, a hollow cone or conical member is employed in a broad definition to include any hollow cavity or body having a circular or other closed plane figure and straight line segments joining every point of the boundary of the plane figure to a common vertex.

The present invention thus provides a highly improved cavity resonator having discriminating means to minimize interference between undesired modes and the desired mode by either dissipating the undesired modes and by preventing simultaneous resonance in two modes.

Various modes of carrying out the invention are contemplated as being within the scope of the following claims particularly pointing out and distinctly claiming the subject matter which is regarded as the invention.

I claim:

1. A cavity resonator comprising, a hollow conical member having an inner face of conductive material, said member having a limiting cross-section portion selected to propagate waveguide modes below a selected mode and a resonating portion of larger cross-section extending from said limiting diameter portion,

means for introducing energy into the cavity, and an end reflecting boundary means to reflect the energy in the conical member, said boundary means being spaced with respect to the limiting cross-section portion pertaining to the selected mode.

2. The cavity resonator of claim 1 wherein the internal conductive surface of the resonating portion is of the form of a truncated right circular cone.

3. The cavity resonator of claim 1 wherein the conical member has the form of a truncated cone and the limiting diameter portion is located in the small end of the truncated cone.

4. The cavity resonator of claim 1 wherein said reflecting means includes a reflecting face in the form of a curved surface of a spherical segment.

5. The cavity resonator of claim 4 having means to adjust the radius of the spherical reflecting surface.

6. The cavity resonator of claim 1 wherein said reflecting means includes a movable wall disposed within the resonating portion to essentially close the end of the cavity and means connected to the movable wall for selectively positioning thereof for tuning the cavity.

7. The cavity resonator of claim 6 wherein the resonating portion includes a truncated cone terminating at the large end in a cylindrical section and said movable wall is mounted within the cylindrical section.

8. The cavity resonator of claim 1 wherein the conical member is truncated and terminates in a small diameter tubular section connected to the small diameter and a large diameter tubular section connected to the large diameter resonating portion, said end reflecting boundary means being disposed within said large diameter tubular section.

9. The cavity resonator of claim 8 wherein the reflecting boundary means is a plunger movably mounted in the large end of the resonating portion, the diameter of the plunger being slightly less than the minimum aligned diameter of the conical member to maintain a small gap between the periphery of the plunger and the conical member.

10. The cavity resonator of claim 1 having means forming a part of the small diameter section defining an energy dissipating means.

11. A cavity resonator comprising, a tubular member having an inner face of conducting material, said member having a small diameter section capable of propagating modes only below a selected TE_{01} mode and a large diameter mode propa-

9

gating section connected to and extending coaxially from the small diameter section, said mode propagating section including a truncated cone having a minimum diameter incapable of propagating the selected mode and capable of propagating all lower TE₀₁ modes, 5

a movable wall disposed to essentially close the outer end of the large diameter section to form a resonating cavity at the selected TE₀₁ mode with the boundary defined by the tubular member, the wall means and the apparent wall means defined by the small diameter section, and 10

means for introducing energy of the selected TE₀₁ mode into the side wall of the tubular member in the region of the mode propagating diameter portion to essentially prevent excitation of TM modes. 15

12. A cavity resonator comprising,

a tubular member having an inner face of conducting material, said member having a small diameter portion capable of propagating modes only below a selected mode and a connected large diameter reso-

10

nating portion capable of sustaining the selected mode and all higher modes, said tubular member including an outer cylindrical end extension in said resonating portion,

a reflecting wall unit disposed within the cylindrical portion to form a resonating cavity at a selected mode with the boundary defined by the tubular member, the wall means and the apparent wall means defined by the small diameter section, and

means for introducing energy of the selected mode into the cavity in the region of the connection of limiting portion to the resonating portion.

References Cited

UNITED STATES PATENTS

2,460,090	1/1949	Kannenber	-----	333—83
2,600,186	6/1952	Baños	-----	333—83

HERMAN KARL SAALBACH, *Primary Examiner*.
 LOUIS ALLAHUT, *Assistant Examiner*.