



- (51) **International Patent Classification:**
B65H 1/00 (2006.01)
- (21) **International Application Number:**
PCT/US2010/037412
- (22) **International Filing Date:**
4 June 2010 (04.06.2010)
- (25) **Filing Language:** English
- (26) **Publication Language:** English
- (30) **Priority Data:**
12/478,607 4 June 2009 (04.06.2009) US
- (71) **Applicant (for all designated States except US):** **GTECH CORPORATION** [US/US]; Gtech Corporation, Gtech Center, 10 Memorial Boulevard, Providence, Rhode Island 02903 (US).
- (72) **Inventor; and**
- (75) **Inventor/Applicant (for US only):** **BUSINGER, Kurt L.** [US/US]; Kurt L. Businger, 45 Barren Hill Dr., Warwick, Rhode Island 02886 (US).
- (74) **Agent:** **BERGERT, Thomas F.**; Williams Mullen, PC, 321 E. Main Street, Suite 400, Charlottesville, Virginia 22902 (US).
- (81) **Designated States (unless otherwise indicated, for every kind of national protection available):** AE, AG, AL, AM, AO, AT, AU, AZ, BA, BB, BG, BH, BR, BW, BY, BZ,

CA, CH, CL, CN, CO, CR, CU, CZ, DE, DK, DM, DO, DZ, EC, EE, EG, ES, FI, GB, GD, GE, GH, GM, GT, HN, HR, HU, ID, IL, IN, IS, JP, KE, KG, KM, KN, KP, KR, KZ, LA, LC, LK, LR, LS, LT, LU, LY, MA, MD, ME, MG, MK, MN, MW, MX, MY, MZ, NA, NG, NI, NO, NZ, OM, PE, PG, PH, PL, PT, RO, RS, RU, SC, SD, SE, SG, SK, SL, SM, ST, SV, SY, TH, TJ, TM, TN, TR, TT, TZ, UA, UG, US, UZ, VC, VN, ZA, ZM, ZW.

(84) **Designated States (unless otherwise indicated, for every kind of regional protection available):** ARIPO (BW, GH, GM, KE, LR, LS, MW, MZ, NA, SD, SL, SZ, TZ, UG, ZM, ZW), Eurasian (AM, AZ, BY, KG, KZ, MD, RU, TJ, TM), European (AL, AT, BE, BG, CH, CY, CZ, DE, DK, EE, ES, FI, FR, GB, GR, HR, HU, IE, IS, IT, LT, LU, LV, MC, MK, MT, NL, NO, PL, PT, RO, SE, SI, SK, SM, TR), OAPI (BF, BJ, CF, CG, CI, CM, GA, GN, GQ, GW, ML, MR, NE, SN, TD, TG).

Declarations under Rule 4.17:

- as to applicant's entitlement to apply for and be granted a patent (Rule 4.17(ii))
- as to the applicant's entitlement to claim the priority of the earlier application (Rule 4.17(iii))

Published:

- with international search report (Art. 21(3))

(54) **Title:** TICKET MAGAZINE FOR INSTANT TICKET DISPENSING MACHINE

FIG. 6

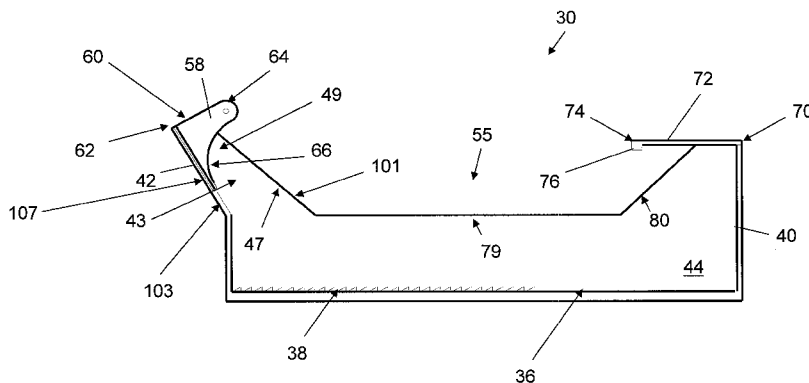

(57) **Abstract:** The present invention provides a ticket magazine that can be inserted into a drawer of a ticket dispensing machine. The magazine can be loaded with tickets externally from the machine, and provides an element or elements such as one or more bridging fingers and/or a dancer arm to enable the tickets to travel along a more advantageous ticket path with longer curl diameters. Because of the longer curl diameter, the pull force required to peel a ticket from the stack is reduced and remains substantially constant, thereby avoiding ticket jams, mis-cuts and other problems.

WO 2010/141823 A1

Ticket Magazine for Instant Ticket Dispensing MachineTechnical Field

The present invention relates to article dispensing systems, and more particularly to an article, system and method for improving lottery ticket dispensing systems.

Background Art

Lottery ticket dispensing machines typically store packs of lottery tickets in fan-folded form and dispense the tickets in an automated fashion in order to reduce clerical involvement and facilitate efficient ticket processing. Each ticket pack typically contains up to three hundred individual tickets, each of which is joined to an adjacent ticket by perforation or some other line of weakness to facilitate separation. In a high volume machine, the ticket packs may be taped together such that there may potentially be up to 1,200 tickets or more in a continuous pack. The ticket packs typically range from four to twelve inches in length, and from one to three inches in height.

An example of a known lottery ticket dispensing machine and its elements is shown in Figs. 1 and 2. As shown therein, a ticket dispensing machine 10 for dispensing lottery tickets is provided with a drawer 12 for receiving packs of tickets 14 to be dispensed. The ticket packs are typically fan-folded and rest in a stack until processed. The machine will typically include one or more guide rollers 15 and a burster element 16 having feed rollers 13 and a powered ticket transport mechanism 18 for processing tickets through a slot 20. The guide roller(s) can be permanently or removably secured into the drawer and made part of the overall machine. During processing, sheets of the ticket pack are lifted, guided over the roller 15 and fed into the bursting element 16. On command from a main controller (not shown), the ticket sheet is advanced one length, separated by the burster element 16 and delivered to the ticket chute or slot 20.

Traditional lottery ticket dispensing machines that store tickets in a fan-fold stream have many disadvantages. For example, it is often difficult to load the ticket drawer, especially if the ticket pack is high. Further, the operator, such as a retail store clerk, for example, can forget to put the ticket over the guide roller, which will inevitably result in tickets sticking together to produce ticket jams. Also, as shown in Figs. 1 and 2, curls 17 in the ticket path are formed, creating a tortuous path (e.g., "S"

curls) for the tickets to travel during processing. If the ticket sits for a long time in this position in the drawer, the ticket can set permanently in a curl, which can cause the ticket to get caught and/or hung up on the exit side of the bursting element.

Further, it is often the case with longer tickets, such as those six inches or longer, for example, that operating instructions will require such longer tickets to be fed under the guide roller to avoid the curls. If the retail clerk or other machine operator is unaware of, or simply forgets, the different instructions, he or she may feed the longer tickets above the roller and encounter the same curl problems associated with shorter tickets.

10 In addition to the above, the force required to pull a ticket over the roller can be very high, as much as two pounds per square inch or more. The force is typically sufficient to pull the ticket stack at a rate of approximately seven to eight inches per second. However, this force is not constant depending on the position of the curls and the height of the ticket stack, and since the feed rollers of the bursting element are required to pull the ticket into the bursting element, the varying force can create slippage, resulting in a mis-cut that affects every further ticket downstream. Further, the greater the force that is applied by the feed roller of the bursting element in pulling the ticket over the guide roller, the greater the chances are that the perforation on the tickets in the drawer will be broken, requiring shut down of the machine until it can be fixed.

20 These and other disadvantages to prior systems are described, for example, in U.S. Patent No. 7,467,738, which represents a successful prior art solution to some of these disadvantages. U.S. Patent No. 7,467,738 is assigned to the assignee of this invention and is hereby incorporated by reference in its entirety.

25 Disclosure of Invention

The present invention provides a solution to the above shortcomings and more. Among other things, the present invention provides a ticket magazine that can be inserted into a drawer of a ticket dispensing machine. The magazine can be loaded with tickets externally from the machine, which facilitates accurate and faster overall loading. Further, the ticket magazine provides an element or elements such as one or more bridging fingers and/or a dancer arm that eliminate the need for a guide roller and all of the associated problems therewith, including the S-curls described above. The ticket magazine of the present invention can permit loading of standard ticket pack lengths and heights, while also enabling the tickets to travel along a more

advantageous ticket path with longer curl diameters. Because of the larger curl diameter, the pull force required to peel a ticket from the stack is reduced and remains substantially constant.

5 Brief Description of Drawings

Fig. 1 is a schematic drawing depicting a side view of a portion of a traditional ticket dispensing machine, with a side wall removed to show the interior thereof.

Fig. 2 is a photograph of a ticket dispensing machine with a loaded ticket pack.

10 Fig. 3 is a photograph of one embodiment of a ticket magazine in accordance with the present invention.

Fig. 4 is a photograph showing the ticket magazine of Fig. 3 atop a ticket dispensing machine in accordance with one embodiment of the present invention.

15 Fig. 5 is a photograph showing the ticket magazine of Fig. 3 inserted within a drawer of a ticket dispensing machine in accordance with one embodiment of the present invention.

Fig. 6 is a side view of an alternative embodiment of a ticket magazine in accordance with the present invention, with a wall removed to show the interior of the magazine.

20 Fig. 7 is a side view of a ticket dispensing machine in accordance with the present invention, with a ticket magazine held within a drawer thereof, and with a wall of the machine and the magazine removed to show the interiors thereof.

Modes for Carrying Out the Invention

25 As shown in Figs. 3 through 7, the present invention provides a ticket magazine 30 that can be inserted into a drawer 32 of a ticket dispensing machine 35. In one embodiment of the present invention, the ticket magazine is formed of a durable plastic material using a mold and thermal-forming equipment. The magazine 30 can be provided with a floor 36 having a tread liner element 38 that can be formed
30 as part of the floor during formation of the magazine, or that can be secured to the floor 36 as a separate element by glue, tape or other known method.

The magazine 30 includes lead 40 and side 44 walls, as well as an end wall support member 43 that includes end wall 42. The lead 40 and side 44 walls can be integrally formed with and extend substantially perpendicularly from the floor 36,

such that the lead and side walls are also substantially perpendicular to one another. In the embodiment of the present invention as shown in Figs. 3 and 6, the end wall support member 43 is integrally formed with and extends from a top edge 45 of each side wall 44, and includes a lower portion 47, an upper portion 49 as well as a lead edge 101 and a back edge 103. The end wall support extends from the top edge 45 of each side wall at an angle extending from the lower portion thereof to the upper portion thereof in a direction away from the lead wall 40. The end wall 42 itself does not extend from the floor, but rather extends from the lower portion of the end wall support 43 at a position "A" approximately co-planar with the top edge 45 of the side walls 44. The end wall 42 extends along the same angle and is integral with the back edge 103 of the end wall support member. In one embodiment of the present invention, the end wall is formed with an angle so as to abut a burster element in substantially flush relation as described elsewhere herein. The lead edge 101 of the end wall support member 43 can extend at a different angle from that of the end wall 42, in one embodiment of the present invention.

The bottom edge 50 of the end wall 42 combines with the back edges 52 of the side walls 44 and the floor 36 to form an opening 54, which can be used to insert or unload ticket packs in one embodiment of the present invention. The lead wall 40 and the side walls 44 define an inner compartment 55 for holding the ticket stack. In another embodiment of the present invention, there is no opening 54 and the end wall 42 extends from the floor 36 to the end wall support member upper portion 49. In such an embodiment, ticket stacks can be fed into the ticket magazine from the top.

The end wall 42 includes an inner face 56 from which extend one or more bridging fingers 58, which can be integrally formed with the end wall. In one embodiment of the present invention, the fingers 58 include a substantially linear back edge 60 that lies substantially coplanar with a top edge 62 of the end wall 42. The fingers 58 can also include a rounded tip section 64 and an arcuate or concave lead edge section 66 sloping downwardly from the tip section to substantially mate with the end wall inner face 56. In one embodiment of the present invention as shown in Fig. 3, several fingers 58 are employed across the width W of the end wall 42, extending substantially parallel to one another and substantially parallel with a ticket dispensing path 59. In another embodiment of the present invention, a single solid bridging finger or roller member extends substantially across the width W of the end wall 42.

In the embodiment of the invention as shown in Figs. 6 and 7, the lead wall 40 of the ticket magazine 30 includes a top edge 70 and a dancer arm 72 extending from the top edge 70 into the inner compartment 55. The dancer arm 72 acts as a guide to the ticket pack as it is being transported along ticket path 59 through the ticket
5 dispensing machine. In one embodiment of the present invention, the dancer arm 72 includes an inner edge 74 and a lip member 76 extending downwardly from the inner edge 74 and substantially parallel to the lead wall 40. As shown in Fig. 6, the side walls 44 can include a lead facing portion 80 that extends higher than the mid portion 79, which can add support to the magazine 30 and help contain ticket packs within the
10 inner compartment 55.

In operation, a ticket pack 40 is placed in the inner compartment 55 of the magazine 30 so as to rest on top of the floor 36 and any tread liner element 38. The magazine is typically removed from the drawer and ticket dispensing machine during loading. Once the ticket pack is in the magazine, it can be transported to the machine
15 and placed within the drawer. As shown in Fig. 5, the drawer 32 is within a housing 33 of the ticket dispensing machine 35, as more specifically described, for example, in U.S. Patent No. 7,467,738, which has been incorporated herein by reference. In one embodiment of the present invention, the ticket dispensing machine can be a machine such as a GameGuard™ machine provided by the assignee of the present invention;
20 however, it will be appreciated that other configurations and designs for the machine, drawer and housing associated with the present invention may be used and employed with the present invention. The ticket dispensing machine can include room for a single magazine, or more likely for a plurality of magazines such that the retail operator can sell and dispense multiple ticket types related to multiple lottery games
25 from the same dispensing machine. In one embodiment of the present invention, the ticket dispensing machine includes a burster element 75 that can handle several (e.g., four) magazines per drawer, wherein multiple drawers are arranged in vertical fashion for display and merchandising of the different lottery tickets. The burster element 75 has an internal facing wall 105, which is angled to suit the orientation required for the
30 burster element to operate properly. Advantageously, the buster element internal facing wall 105 can abut the end wall 42 of the ticket magazine 30 in substantially flush relation over substantially the entire back or exterior face 107 of the end wall 42. This arrangement adds stability to the present invention. The drawers are typically capable of being moved to and between an extended position for convenient access to

load and unload the magazines, and a retracted position in which the drawer and magazines are contained in the machine for display and dispensing of tickets.

In the example where the machine handles multiple magazines, the magazines can be loaded at the same time, or at different times depending upon how quickly the individual packs of tickets are dispensed. For retail employees inclined to change
5 packs based on time intervals rather than when the packs are empty, the present invention offers a system that more readily facilitates individual pack replacement.

Once the machine is loaded, the top sheet of tickets is manually fed into the burster element 75 such that the tickets rest atop the bridge finger(s) 58. In the
10 embodiment of the invention with the dancer arm 72, as shown in Fig. 7, the ticket path 59 will extend underneath the dancer arm 72, which helps prevent the ticket pack from popping up when being pulled through. In another embodiment of the present invention, as shown in Fig. 7, a separator element 81 is secured to a ceiling portion 82
15 of the drawer 32 of the ticket dispensing machine 35 to assist in minimizing curls along the ticket path 59. The separator element extends into the inner compartment 55 and can be secured through mechanical means such as double-sided tape, glue or hardware fasteners, for example.

As can be seen in Figs. 4 and 5, for example, the present invention facilitates larger curls 85 for the tickets as they travel along ticket path 59, thereby reducing drag
20 and the chances for ticket jamming, mis-cutting and other problems identified above.

The invention may be embodied in other specific forms without departing from the spirit or essential characteristics thereof. The present embodiments are therefore to be considered in all respects as illustrative and not restrictive, the scope of the invention being indicated by the claims of the application rather than by the
25 foregoing description, and all changes which come within the meaning and range of equivalency of the claims are therefore intended to be embraced therein.

Claims:

1. A ticket magazine for a lottery ticket dispensing machine, comprising:

a floor;

a lead wall and a pair of side walls extending upwardly from and substantially
5 perpendicular to the floor, with each of the side walls including a respective top edge;
and

an end wall support member having a lower portion and an upper portion, with
the end wall support member extending from the top edge of each side wall at an
angle extending from the lower portion thereof to the upper portion thereof in a
10 direction away from the lead wall, with the end wall support member further
including an end wall having an inner face with at least one bridge finger member
secured thereto.

2. The magazine of claim 1 wherein the end wall support member includes a bottom
15 edge and wherein the side walls each include a back edge, and further wherein the end
wall support member bottom edge, the floor and the side wall back edges form an
opening therebetween.

3. The magazine of claim 1 wherein the end wall support member includes a top edge,
20 and wherein the at least one bridge finger includes a substantially linear back edge
that lies substantially coplanar with the end wall support member top edge.

4. The magazine of claim 1 wherein the at least one bridge finger has a rounded tip
section and an arcuate lead edge section that slopes downwardly from the tip section
25 to substantially mate with the end wall inner face.

5. The magazine of claim 1 wherein the end wall has a width, and further wherein the
at least one bridge finger comprises a plurality of bridge fingers substantially parallel
to one another and disposed at substantially equal intervals substantially across the
30 width of the end wall.

6. The magazine of claim 1 wherein the end wall has a width, and further wherein the at least one bridge finger comprises a roller member extending substantially across the width of the end wall.

5 7. The magazine of claim 1 wherein the lead wall includes a top edge, and further including a dancer arm extending from the lead wall top edge.

8. The magazine of claim 7 wherein the dancer arm includes an inner edge and a lip member extending downwardly from the inner edge and substantially parallel to the
10 lead wall.

9. The magazine of claim 1 wherein the floor includes a tread liner element.

10. A lottery ticket dispensing machine, comprising:

15 a housing;

a drawer retained within the housing;

a burster element positioned within the housing and having an internal wall;

and

a ticket magazine positionable within the drawer, with the ticket magazine
20 having a floor, a lead wall and a pair of side walls extending upwardly from and substantially perpendicular to the floor, with the side walls each having a top edge, and wherein the ticket magazine further includes an end wall support member having a lower portion and an upper portion, with the end wall support member extending
25 thereof to the upper portion thereof in a direction away from the lead wall, with the end wall support further including an end wall with an inner face having at least one bridge finger member secured thereto.

11. The machine of claim 10 wherein the burster element has an internal wall, and
30 wherein the end wall has an external face adapted to mate in substantially flush relation with the burster element internal wall.

12. The machine of claim 10 wherein the end wall support member includes a top edge, and wherein the at least one bridge finger includes a substantially linear back edge that lies substantially coplanar with the end wall support member top edge.

5 13. The machine of claim 10 wherein the at least one bridge finger has a rounded tip section and an arcuate lead edge section that slopes downwardly from the tip section to substantially mate with the end wall inner face.

10 14. The machine of claim 10 wherein the end wall has a width, and further wherein the at least one bridge finger comprises a plurality of bridge fingers substantially parallel to one another and disposed at substantially equal intervals substantially across the width of the end wall.

15 15. The machine of claim 14 wherein the plurality of fingers are substantially parallel with a ticket dispensing path.

16. The machine of claim 10 wherein the end wall has a width, and further wherein the at least one bridge finger comprises a roller member extending substantially across the width of the end wall.

20

17. The machine of claim 10 wherein the lead wall includes a top edge, and further including a dancer arm extending from the lead wall top edge.

25 18. The machine of claim 17 wherein the dancer arm includes an inner edge and a lip member extending downwardly from the inner edge and substantially parallel to the lead wall.

30 19. The machine of claim 10 wherein the drawer further includes a ceiling secured thereto and maintained above the inner compartment, and wherein the ceiling includes a separator element secured thereto and extending into the inner compartment.

20. A method for dispensing lottery tickets from a ticket dispensing machine having a housing, at least one drawer, and a burster element having an interior wall, comprising the steps of:

providing a ticket magazine with a floor, a lead wall and a pair of side walls extending upwardly from and substantially perpendicular to the floor, and an end wall support member integrally formed with the side walls and having an end wall with an inner and exterior face;

5 inserting a pack of lottery tickets into the ticket magazine so as to rest on the floor thereof; and

 inserting the ticket magazine into the ticket dispensing machine, with the ticket magazine being positioned such that the interior wall of the burster element abuts, in substantially flush relation, the exterior face of the end wall.

10

21. The method of claim 20 wherein the pack of lottery tickets includes a lead ticket, wherein the ticket magazine end wall inner face includes at least one bridge finger member secured thereto, and wherein the method includes the further step of feeding the lead ticket over the bridge finger and into the burster element of the ticket

15 dispensing machine.

FIG. 1

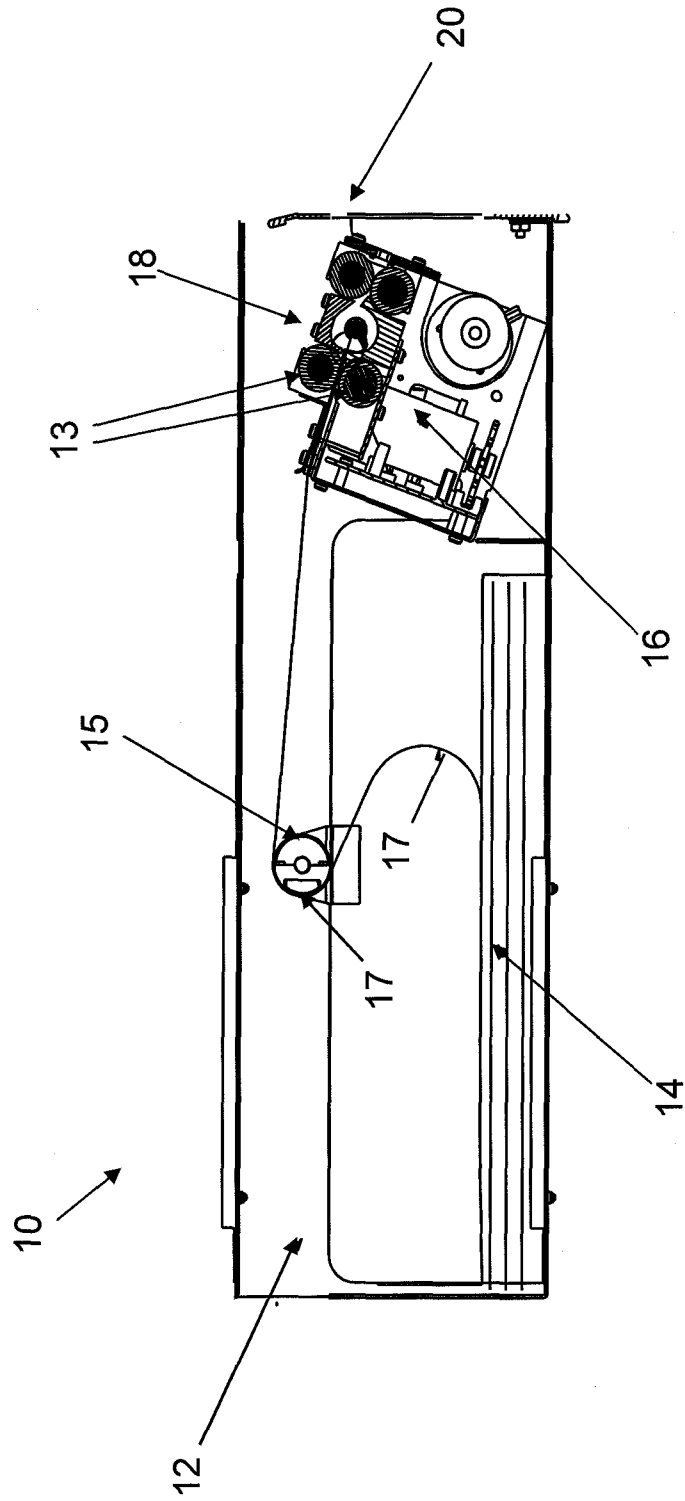

FIG. 2

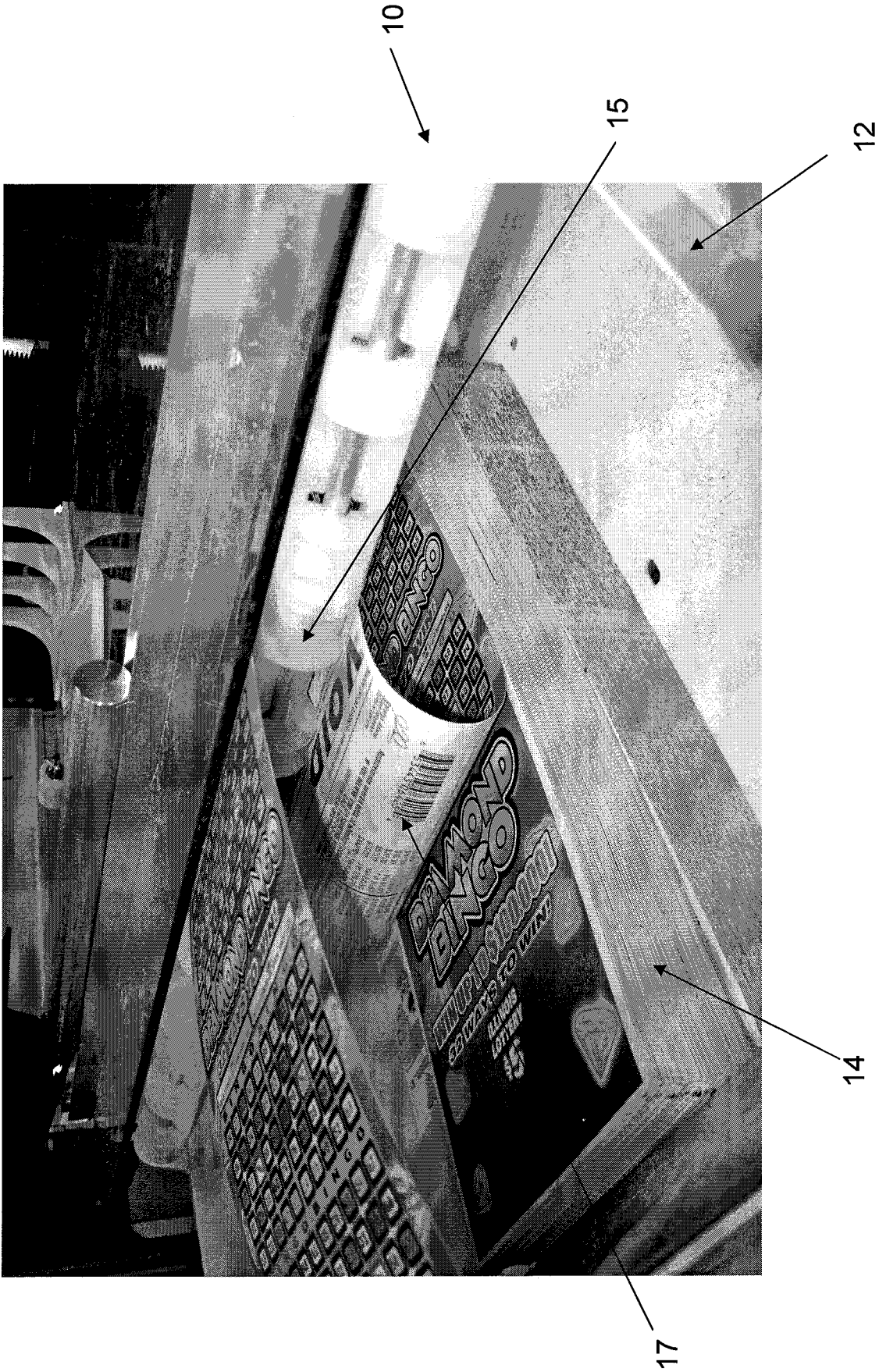

FIG. 3

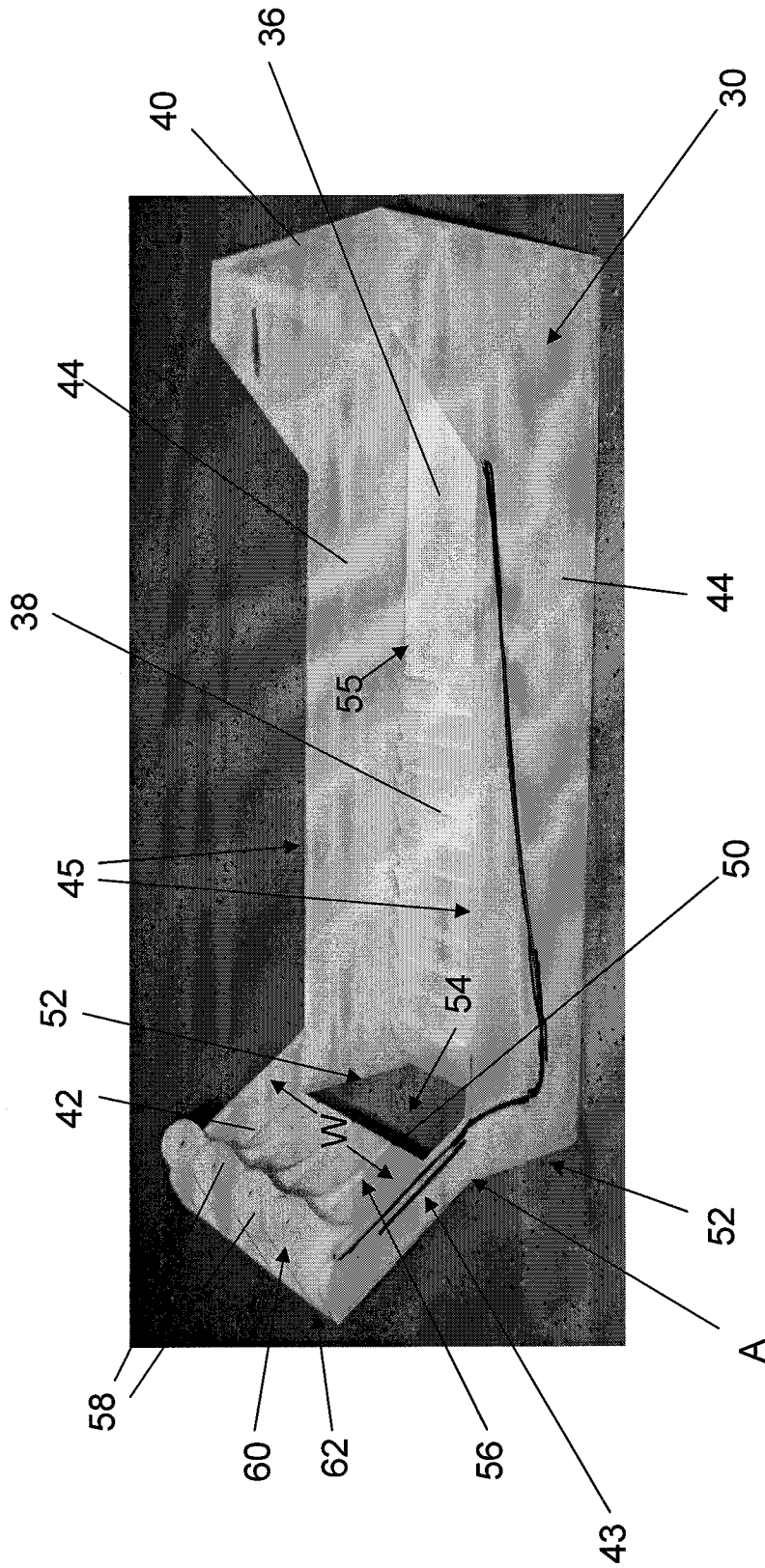

FIG. 4

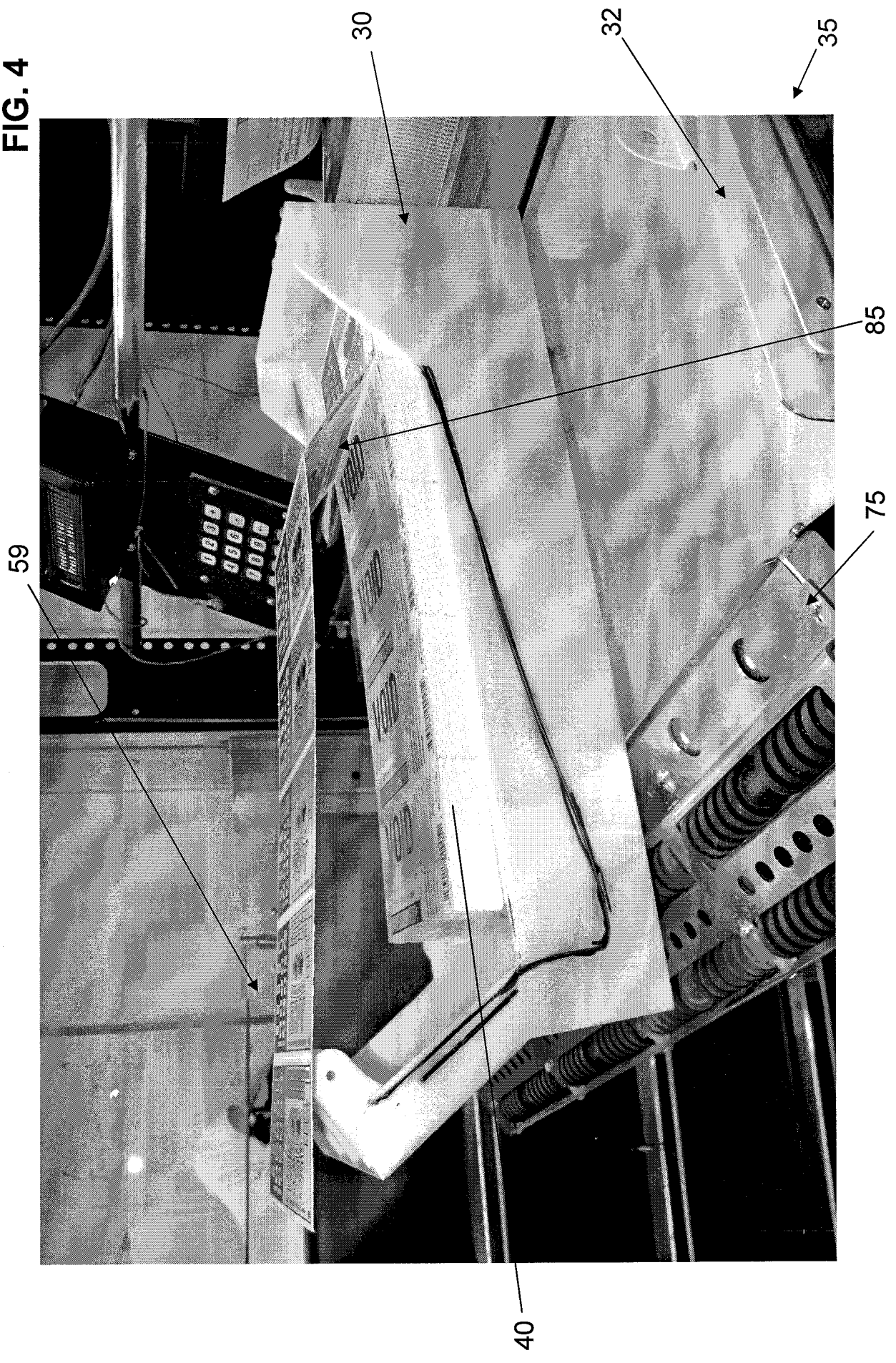

FIG. 5



FIG. 6

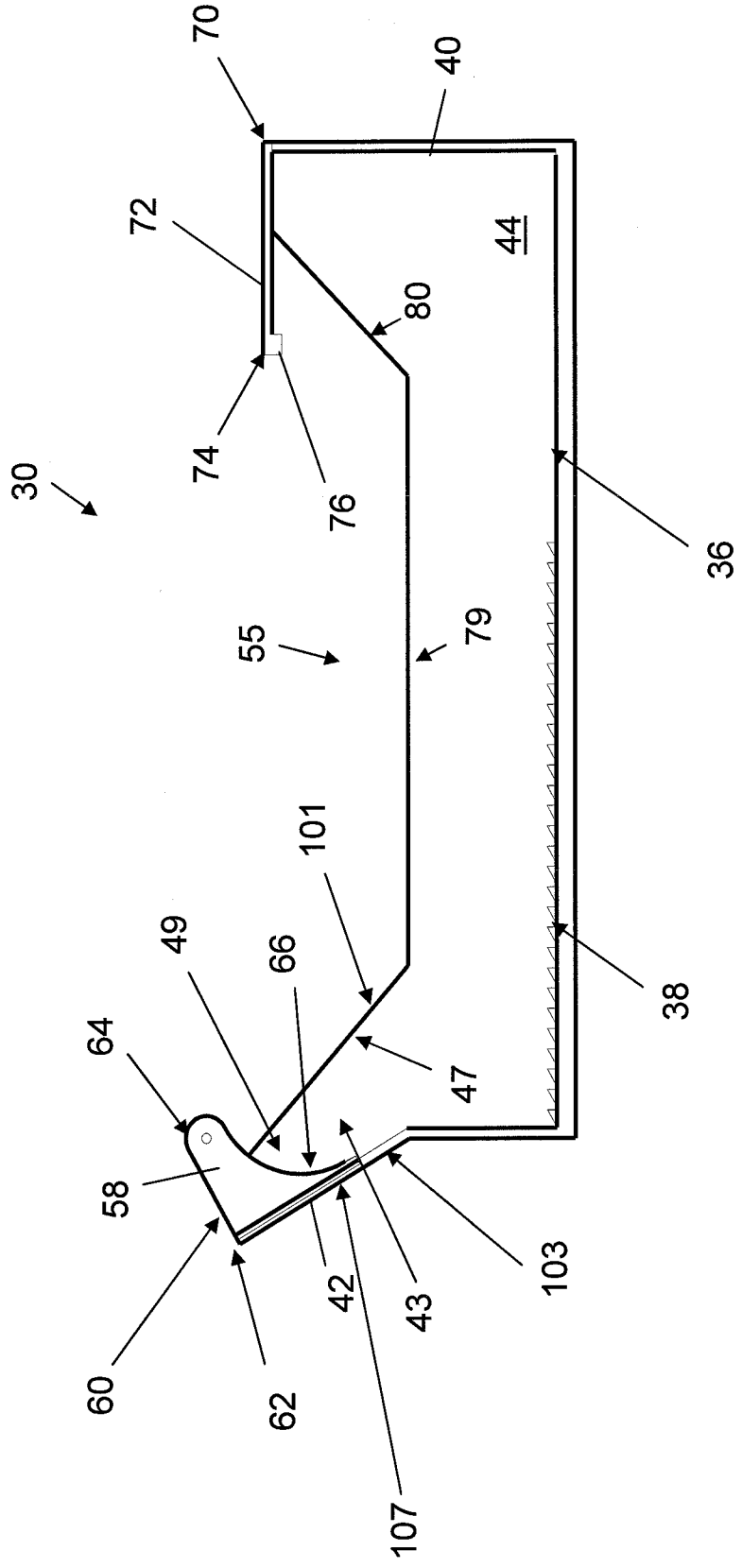
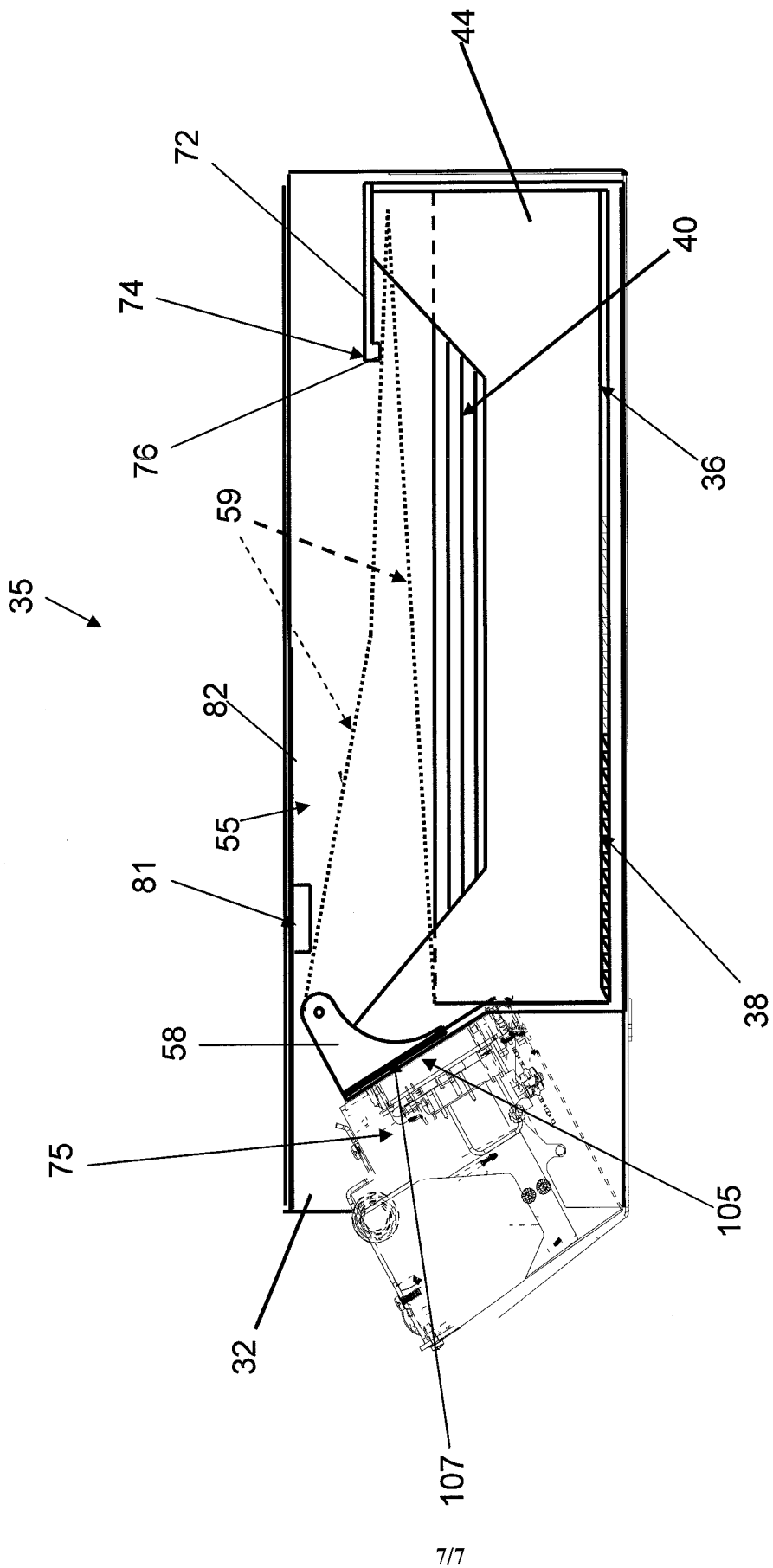

FIG. 7



INTERNATIONAL SEARCH REPORT

International application No.

PCT/US2010/037412

A. CLASSIFICATION OF SUBJECT MATTER

IPC(8) - B65H 1/00 (2010.01)

USPC - 221/163

According to International Patent Classification (IPC) or to both national classification and IPC

B. FIELDS SEARCHED

Minimum documentation searched (classification system followed by classification symbols)

IPC(8) - B23Q 7/12; B65F 9/00; B65H 1/00 (2010.01)

USPC - 221/163

Documentation searched other than minimum documentation to the extent that such documents are included in the fields searched

Electronic data base consulted during the international search (name of data base and, where practicable, search terms used)

MicroPatent

C. DOCUMENTS CONSIDERED TO BE RELEVANT

Category*	Citation of document, with indication, where appropriate, of the relevant passages	Relevant to claim No.
X	US 2005/0184081 A1 (JENSEN) 25 August 2005 (25.08.2005) entire document	1, 3-8
Y		2, 9-21
Y	US 2,812,056 A (JENKINS) 05 November 1957 (05.11.1957) entire document	2
Y	US 6,022,617 A (CALKINS) 08 February 2000 (08.02.2000) entire document	9
Y	US 7,467,738 B2 (WOODS et al) 23 December 2008 (23.12.2008) entire document	10-21

Further documents are listed in the continuation of Box C.

- | | |
|---|--|
| * Special categories of cited documents: | "T" later document published after the international filing date or priority date and not in conflict with the application but cited to understand the principle or theory underlying the invention |
| "A" document defining the general state of the art which is not considered to be of particular relevance | "X" document of particular relevance; the claimed invention cannot be considered novel or cannot be considered to involve an inventive step when the document is taken alone |
| "E" earlier application or patent but published on or after the international filing date | "Y" document of particular relevance; the claimed invention cannot be considered to involve an inventive step when the document is combined with one or more other such documents, such combination being obvious to a person skilled in the art |
| "L" document which may throw doubts on priority claim(s) or which is cited to establish the publication date of another citation or other special reason (as specified) | "&" document member of the same patent family |
| "O" document referring to an oral disclosure, use, exhibition or other means | |
| "P" document published prior to the international filing date but later than the priority date claimed | |

Date of the actual completion of the international search

31 August 2010

Date of mailing of the international search report

09 SEP 2010

Name and mailing address of the ISA/US
 Mail Stop PCT, Attn: ISA/US, Commissioner for Patents
 P.O. Box 1450, Alexandria, Virginia 22313-1450
 Facsimile No. 571-273-3201

Authorized officer:
 Blaine R. Copenheaver

PCT Helpdesk: 571-272-4300
 PCT OSP: 571-272-7774