

(No Model.)

A. E. RHOADES.
ROVING MACHINE.

No. 386,352.

Patented July 17, 1888.

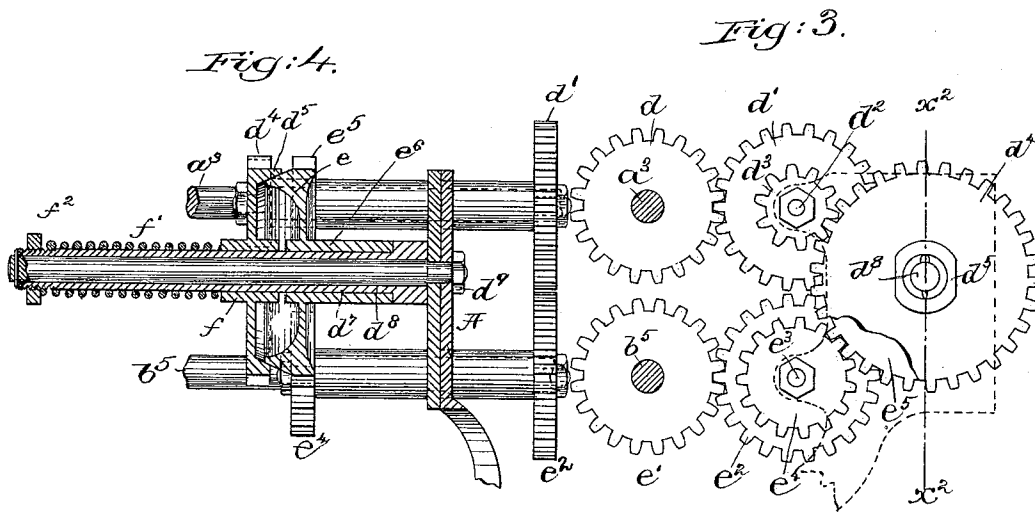
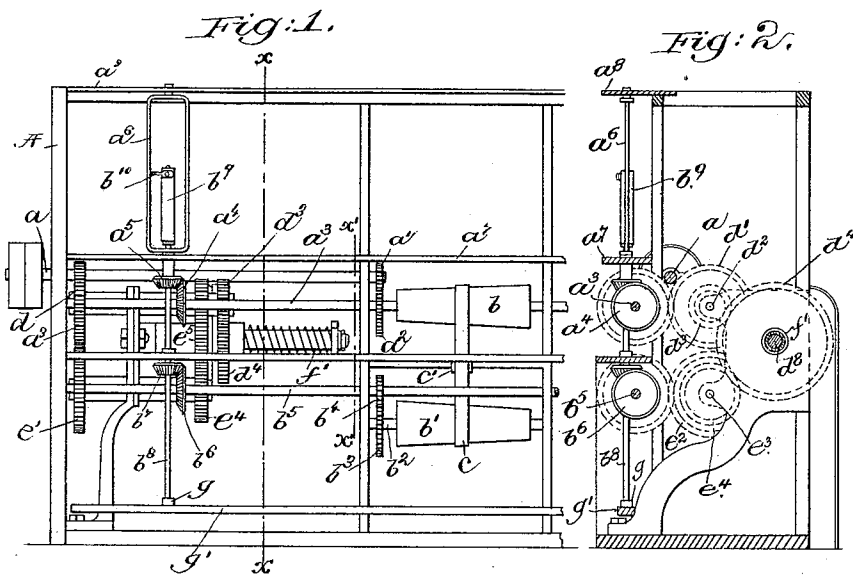

Witnesses.
Howard F. Eaton.
John F. L. Printz

Inventor.
Alonzo E. Rhoades
by Lemuel Langroy. attys

UNITED STATES PATENT OFFICE.

ALONZO E. RHOADES, OF MILFORD, MASSACHUSETTS, ASSIGNOR TO THE
HOPEDALE MACHINE COMPANY, OF HOPEDALE, MASSACHUSETTS.

ROVING-MACHINE.

SPECIFICATION forming part of Letters Patent No. 386,352, dated July 17, 1888.

Application filed August 23, 1887. Serial No. 247,646. (No model.)

To all whom it may concern:

Be it known that I, ALONZO E. RHOADES, of Milford, county of Worcester, and State of Massachusetts, have invented an Improvement in Roving-Machines, of which the following description, in connection with the accompanying drawings, is a specification, like letters on the drawings representing like parts.

In the production of roving on roving-machines using fliers the roving is frequently stretched and weakened by starting or stopping the flier before the bobbin, this being due to what is known as "backlash."

In roving-machines using a flier, the class of machine upon which the present invention is an improvement, the fliers are usually rotated at a uniform speed, while the bobbins, when they begin to receive yarn, run at a slower speed, their speed being gradually increased as the bobbins are filled; but the speed attained by the bobbins does not equal that of the fliers. So, also, in this class of machine the fliers are driven from the flier-driving shaft, whereas the bobbins are driven from a bobbin-driving shaft set in motion by the flier-driving shaft and intermediate gearing, and as a result the backlash is different in degree, being perceptible most at the bobbin.

In my experiments to increase the speed of roving-machines I discovered that means must be provided to overcome this backlash and the resultant stretching of the roving or yarn between the flier and bobbin, as the flier starts first; and to overcome this objection and insure the starting of the flier and bobbin together I have interposed a friction device between the shafts actuating the fliers and the bobbins, the said friction device, as herein shown, consisting of two plates pressed together in a yielding manner, the said plates being driven positively, one from the flier-actuating shaft and the other from the bobbin-actuating shaft, the speed of the disks or plates of the friction device varying relatively the one to the other as the difference in the speed of the fliers and bobbins.

My invention consists, essentially, in the combination, with the flier and bobbin actuating shafts, of an intermediate friction device and gearing to actuate the same, whereby the said bobbin and flier actuating shafts are al-

ways stopped and started at the same instant, as will be described.

Figure 1 in front elevation shows a sufficient portion of a roving machine embodying my invention to enable my improvements to be understood. Fig. 2 is a section of Fig. 1 in the line $x x$, looking toward the left. Fig. 3 is an enlarged detail of the friction device and the gearing connected therewith to the left of the dotted line $x' x'$, Fig. 1, one half of one of the plates of the friction device being broken out to show the other half of the friction device of the same size behind it; and Fig. 4 is a section of Fig. 3 in the dotted line x'' .

The frame-work A, of proper shape to sustain the working parts, has a driving-shaft, a , provided with usual fast and loose pulleys.

As herein shown, the shaft a has a pinion, a' , which engages a toothed gear, a'' , fast on the flier-actuating shaft a''' , it having a suitable number of beveled gears, as a''' , which engage each a beveled gear, as a'''' , on the tubular neck of the flier a''''' , the said neck taking its bearing in the rail a'''''' , while the nose of the flier takes its bearing in a suitable rail, a''''''' .

The flier-driving shaft a''' has fast upon it one pulley, b , of a pair of cone-pulleys, the second cone-pulley, as b' , being fast upon a short shaft, as b'' , having toothed gear b''' , which engages a pinion, b'''' , fast on the bobbin-driving shaft b''''' , it having one or more beveled gears, as b'''''' , which engage each a beveled gear, as b''''''' , on and adapted to rotate the spindle b'''''''' , which in usual manner drives the bobbin b''''''''' , upon which is to be wound the yarn issuing from the presser b'''''''''' of the flier.

The belt c , passed about the cone-pulleys $b b'$, is shifted at the proper times by a belt-shipper, c' , so as to vary as may be desired the relative speeds of the two shafts $a''' b'''''$.

I do not desire to limit my invention to the exact devices shown for driving the flier and bobbin actuating shafts, as instead they may be driven by any usual devices commonly employed in roving-frames.

The particular manner of driving the said bobbin-driving shaft is immaterial, as it may be driven from the flier-driving shaft through a "compound motion," as it is called, as commonly done in cotton-mills.

The flier-actuating shaft a''' has fast upon it

a toothed gear, d , (see Fig. 3,) which engages a toothed gear, d' , on a shaft, d^2 , held within and directly at the rear of the shaft a^3 , the said shaft d^2 having secured to it a pinion, d^3 , which
 5 engages the toothed periphery d^4 of the plate or disk d^5 , constituting one half of the friction device, the other half being a plate or disk, e , the contacting surfaces of the said plates or disks being preferably beveled to fit one into
 10 the other, as best shown in Fig. 4.

The disk or plate d^5 and its toothed surfaces d^4 constitute, preferably, an integral part of a hub, f , mounted loosely upon a sleeve, d^7 , in turn mounted loosely upon a stud, d^8 , connected to a part of the frame-work by a suitable nut, d^9 . A spiral spring placed upon the sleeve d^7 and controlled by a nut, f^2 , screwed upon a short part of the said sleeve d^7 , causes the friction plate or disk d^5 to be pressed with
 15 more or less force against the surface of the friction plate or disk e .

The bobbin-driving shaft b^5 has fast upon it a toothed gear, e' , which in turn engages a toothed gear, e^2 , fast upon a shaft, e^3 , parallel
 25 with and directly back of the shaft b^5 , the said shaft e^3 having fast upon it a toothed pinion, e^4 , which engages the toothed portion e^5 of the disk or plate e , (see Fig. 3,) where the disk or plate d^5 is broken away to show the disk or
 30 plate e , which is of the same diameter, behind it. The disk or plate e and its toothed portion e^5 form part of a hub, e^6 , which also runs loose on the sleeve d^7 .

As described, it will be understood that the
 35 disk or plate d^5 is driven positively from the fier-actuating shaft, while the disk or plate e is driven positively from the bobbin-actuating shaft, each disk being driven at a speed corresponding with the said shafts.

40 The disks or plates, being pressed together as described, constitute a friction device or clutch which effectually does away with all backlash referred to, and insures not only

the stopping but also the starting together of both the fier and the bobbin.

Herein I have shown but one fier and one bobbin; but it will be understood that the shafts a^3 b^5 may be provided with any desired number of beveled gears to actuate any desired number of fiers and spindles.

The spindle b^8 rests in a foot-step, g , in the step-rail g' , of usual construction.

From the foregoing description it will be understood that in that class of machine wherein the bobbin-driving shaft is rotated
 55 from the fier-driving shaft through the intervention of toothed gearing alone there is and must be between the teeth a certain amount of looseness, which constitutes backlash, the backlash being increased as the
 60 number of gears are increased; but by interposing a friction device, as herein provided for, between the fier-driving shaft and the bobbin-driving shaft, both of the said shafts start and
 65 stop together, yet the friction between the friction-plates is not so great but that one of the plates slips on or with relation to the other as the relative speed of the two shafts a^3 b^5 is gradually changed by shifting the belt upon
 70 the cone-pulleys.

I claim—

The fier-driving shaft and bobbin-driving shaft of a roving-machine, combined with a friction device and with means to automatically actuate the different portions of the said
 75 friction device from the said shafts, whereby the rotation of the said shafts is stopped and started at the same instant of time, thus avoiding backlash.

In testimony whereof I have signed my name
 80 to this specification in the presence of two subscribing witnesses.

ALONZO E. RHOADES.

Witnesses:

E. D. BANCROFT,
 H. LAWRENCE.