



(51) International Patent Classification:

B65D 30/22 (2006.01) B65D 33/02 (2006.01)
B65D 30/28 (2006.01)

(21) International Application Number:

PCT/IB2019/053613

(22) International Filing Date:

02 May 2019 (02.05.2019)

(25) Filing Language:

English

(26) Publication Language:

English

(30) Priority Data:

62/667,329 04 May 2018 (04.05.2018) US
16/155,492 09 October 2018 (09.10.2018) US
16/192,268 15 November 2018 (15.11.2018) US

(71) Applicant: **1958658 ONTARIO INC.** [CA/CA]; c/o Ar-ranti Inc., 44 Crawford Cr., 2nd Floor, Campbellville, Ontario L0P 1B0 (CA).

(72) Inventors: **HERRINGTON, Jeffrey, G.**; 8083 First Line, Nassagaweya, Ontario L0P 1B0 (CA). **BEDROSIAN, Michael, L.**; 34 Robin Rd., Guelph, Ontario N1L 1B4 (CA).

(81) Designated States (unless otherwise indicated, for every kind of national protection available): AE, AG, AL, AM, AO, AT, AU, AZ, BA, BB, BG, BH, BN, BR, BW, BY, BZ, CA, CH, CL, CN, CO, CR, CU, CZ, DE, DJ, DK, DM, DO,

DZ, EC, EE, EG, ES, FI, GB, GD, GE, GH, GM, GT, HN, HR, HU, ID, IL, IN, IR, IS, JO, JP, KE, KG, KH, KN, KP, KR, KW, KZ, LA, LC, LK, LR, LS, LU, LY, MA, MD, ME, MG, MK, MN, MW, MX, MY, MZ, NA, NG, NI, NO, NZ, OM, PA, PE, PG, PH, PL, PT, QA, RO, RS, RU, RW, SA, SC, SD, SE, SG, SK, SL, SM, ST, SV, SY, TH, TJ, TM, TN, TR, TT, TZ, UA, UG, US, UZ, VC, VN, ZA, ZM, ZW.

(84) Designated States (unless otherwise indicated, for every kind of regional protection available): ARIPO (BW, GH, GM, KE, LR, LS, MW, MZ, NA, RW, SD, SL, ST, SZ, TZ, UG, ZM, ZW), Eurasian (AM, AZ, BY, KG, KZ, RU, TJ, TM), European (AL, AT, BE, BG, CH, CY, CZ, DE, DK, EE, ES, FI, FR, GB, GR, HR, HU, IE, IS, IT, LT, LU, LV, MC, MK, MT, NL, NO, PL, PT, RO, RS, SE, SI, SK, SM, TR), OAPI (BF, BJ, CF, CG, CI, CM, GA, GN, GQ, GW, KM, ML, MR, NE, SN, TD, TG).

Published:

- with international search report (Art. 21(3))
- in black and white; the international application as filed contained color or greyscale and is available for download from PATENTSCOPE

(54) Title: STAND-UP POUCH WITH MULTIPLE COMPARTMENTS

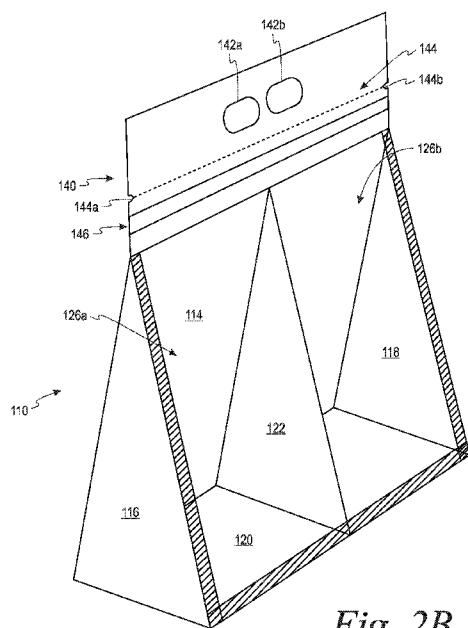

Fig. 2B

(57) Abstract: A gusseted stand-up flexible pouch including a pouch-forming structure. The pouch-forming structure including first and second body panels, first and second side gussets, a bottom gusset and at least one interior gusset. The bottom gusset extends between the first and second body panels. Each of the first and second side gussets is joined to the first and second body panels. The at least one interior gusset is joined to the first and second body panels. The at least one interior gusset is located between the first and second side gussets. The at least one interior gusset divides an interior of the stand-up flexible pouch into a plurality of compartments.



STAND-UP POUCH WITH MULTIPLE COMPARTMENTS

CROSS-REFERENCE TO RELATED APPLICATION

[0001] The present invention claims priority to U.S. Patent Application No. 16/192,268 filed on November 15, 2018, U.S. Patent Application No. 16/155,492 filed on October 9, 2018, and U.S. Provisional Patent Application No. 62/667,329 filed on May 4, 2018, each of which is incorporated herein by reference in its entirety.

FIELD OF THE INVENTION

[0002] The present invention relates generally to stand-up flexible pouches for packaging. More specifically, the present invention relates to gusseted stand-up flexible pouches with multiple compartments or chambers.

BACKGROUND OF THE INVENTION

[0003] Various types of stand-up flexible pouches or packages are known in the art. These stand-up flexible pouches are widely used for packaging liquids, pastes, granulars, powders and the like. Stand-up pouches are designed to stand on their own once they are filled with product. The bottom gusset of the pouches expands when filled, which gives the pouch a solid base on which to stand. Manufacturers desire stand-up pouches because, when they are empty, they weigh very little and can be stored completely flat. Stand-up pouches also take up much less shelf space than traditional boxes, bottles or cans. Since space costs money, whether in inventory or in freight, stand-up flexible pouches assist in decreasing the costs associated with transportation and storage. The transportation and storage savings are further improved because using stand-up pouches eliminates or reduces the need for more containers and lids.

[0004] In recent times, beverage makers have begun to use stand-up pouches with gussets. And, unlike bottles and cans, nearly every single drop of liquid may be removed from a pouch. For food products that require cooking, stand-up pouches are desirable because they allow for the contents to be heated, re-heated or even cooked inside the stand-up pouch.

[0005] One potential drawback with stand-up pouches is the inability to form multiple compartments therein. The typical way of forming compartments in pouches without bottom gussets is by dividing the interior space by one or more heat seals. However, using one or more heat seals will likely damage and/or prevent the functionality of the bottom gussets of the stand-up pouches.

[0006] It would be desirable to provide a stand-up pouch having more flexibility with product packaging, especially in situations where a combination of products is offered.

SUMMARY

[0007] According to one embodiment, a gusseted stand-up flexible pouch comprises a pouch-forming structure including first and second opposing body panels, first and second opposing side gussets, a bottom gusset and at least one interior gusset. The bottom gusset extends between the first body panel and the second body panel. Each of the first and second side gussets is joined to the first body panel and the second body panel. The at least one interior gusset is joined to the first body panel and the second body panel. The at least one interior gusset is located between the first side gusset and the second side gusset. The at least one interior gusset divides an interior of the stand-up flexible pouch into a plurality of compartments.

[0008] According to another embodiment, a gusseted stand-up flexible pouch comprises a pouch-forming structure including first and second opposing body panels, first and second opposing side gussets, a bottom gusset and a plurality of interior gussets. The bottom gusset extends between the first body panel and the second body panel. Each of the first and second side gussets is joined to the first body panel and the second body panel. Each of the plurality of interior gussets is joined to the first body panel and the second body panel. Each of the plurality of interior gussets is located between the first side gusset and the second side gusset. The plurality of interior gussets divides an interior of the stand-up pouch into a plurality of compartments.

[0009] According to one method, a gusseted stand-up flexible pouch is formed. A sheet of film having a first side and a second side is provided. The sheet of film is folded to form a bottom gusset. The sheet of film has an open end opposite of the bottom gusset. Side gusset-forming material and interior gusset-forming material are placed between the first and second sides of the sheet of film. The side gusset-forming material is cut to form first and second side gussets. The first and second side gussets are sealed to interior surfaces of the first side and the second side. The interior gusset-forming material is sealed to interior surfaces of the first side and the second side to form at least one interior gusset. After cutting and sealing, the at least one interior gusset divides an interior of the stand-up flexible pouch into a plurality of compartments.

[0010] The above summary is not intended to represent each embodiment or every aspect of the present invention. Additional features and benefits of the present invention are apparent from the detailed description and figures set forth below.

BRIEF DESCRIPTION OF THE DRAWINGS

[0011] Other advantages of the invention will become apparent upon reading the following detailed description and upon reference to the drawings in which:

[0012] FIG. 1 is a perspective view of a typical PRIOR ART stand-up pouch with exactly one inner compartment (depicted without a front panel to show the interior of the pouch).

[0013] FIG. 2A is a perspective view of a two-compartment stand-up flexible pouch according to one embodiment of the present invention.

[0014] FIG. 2B is a perspective view of the two-compartment stand-up flexible pouch of FIG. 2A without the front panel to show the interior of the pouch.

[0015] FIG. 3A is a perspective view of a two-compartment stand-up flexible pouch according to another embodiment of the present invention.

[0016] FIG. 3B is a perspective view of the two-compartment stand-up flexible pouch of FIG. 3A without the front panel to show the interior of the pouch.

[0017] FIG. 3C is a perspective view of the two-compartment stand-up flexible pouch of FIG. 3A with a second line of weakness according to yet another embodiment.

[0018] FIG. 4 is a perspective view of a two-compartment stand-up flexible pouch with a plurality of windows according to another embodiment of the present invention.

[0019] FIG. 5 is a perspective view of a two-compartment stand-up flexible pouch with a spout or dispensing mechanism according to another embodiment of the present invention.

[0020] FIG. 6A is a perspective view of a three-compartment stand-up flexible pouch according to another embodiment of the present invention.

[0021] FIG. 6B is a perspective view of the three-compartment stand-up flexible pouch of FIG. 6A without the front panel to show the interior of the pouch.

[0022] FIG. 7A is a top perspective view of film and a plurality of gusset-forming material according to one method.

[0023] FIG. 7B is a side perspective of the film and the plurality of gusset-forming material of FIG. 7A.

[0024] FIG. 7C is an enlarged bottom perspective view of the film and plurality of gussets of FIG. 7B after being separated and forming a pouch.

[0025] FIG. 8A is a top perspective view of film and a plurality of gusset-forming material according to one method.

[0026] FIG. 8B is a side perspective of the film and the plurality of gusset-forming material of FIG. 8A.

[0027] FIG. 8C is an enlarged bottom perspective view of the film and plurality of gussets of FIG. 8B after being separated and forming a pouch.

[0028] While the invention is susceptible to various modifications and alternative forms, specific embodiments thereof have been shown by way of example in the drawings and will herein be described in detail. It should be understood, however, that it is not intended to limit the invention to the particular forms disclosed, but on the contrary, the intention is to cover all modifications, equivalents, and alternatives falling within the spirit and scope of the invention as defined by the appended claims.

DETAILED DESCRIPTION

[0029] As shown in PRIOR ART FIG. 1, a typical prior art stand-up pouch 10 includes a front body panel (not shown in FIG. 1), a back body panel 14, two side gussets 16, 18 and a bottom gusset 20. The stand-up pouch 10 includes a top portion 40 that forms hang or carry holes 42a, 42b. The top portion 40 of the stand-up pouch 10 includes tear-notches and/or tear-lines 44 and a resealable zipper 46. The stand-up pouch 10 of FIG. 1 includes exactly one compartment.

[0030] Referring now to the present invention, FIGS. 2A and 2B depict a two-compartment stand-up flexible pouch 110 according to one embodiment. Stand-up flexible pouches are designed to stand on their own once they are filled with product. The main advantage of the stand-up flexible pouches of the present invention is the ability to package together two or more products, which may be products that are traditionally marketed together.

[0031] The stand-up flexible pouch 110 includes a first or front body panel 112 (FIG. 2A only), a second or back body panel 114 (FIG. 2B), two side gussets 116, 118, a bottom gusset 120, an interior gusset 122 (FIG. 2B only) and a top portion 140. FIG. 2B depicts the two-compartment stand-up pouch 110 without the first body panel 112 to show an interior of the pouch including the interior gusset 122.

[0032] The first and second body panels 112, 114 are desirably smoothly integrated with each other (i.e., without visible seaming). In such embodiments, this allows for high-quality graphics to be printed on the surfaces of the first and second body panels 112, 114 without significant distortion or unsightly seam lines.

[0033] The two side gussets 116, 118 of FIGS. 2A and 2B are shown as being a generally triangular shape. It is contemplated that other shapes may be used in forming the two side gussets. For example, the side gussets may be of a generally rectangular, generally square or a generally elongated oval shape. It is contemplated that the side gussets may be of other shapes.

[0034] The bottom gusset 120 extends between the first body panel 112 and the second body panel 114. As shown in FIG. 2B, the bottom gusset 120 extends between the first and second side gussets 116, 118. The bottom gusset 120 allows the pouch to stand upright when it is filled with product. Each of the first and second side gussets 116, 118 is joined to the first body panel 112 and the second body panel 114. Each of the first and second side gussets 116, 118 is also typically joined to the bottom gusset 120.

[0035] As shown in FIG. 2B, the bottom gusset 120 is configured to form a flat bottom in an upright configuration. The flat bottom in FIG. 2B is in the shape of a box. The flat bottom extends between the first and second body panels 112, 114. The flat bottom further extends between the first and second side gussets 116, 118. The flat bottom has an interior surface and an exterior surface. The entire exterior surface of the flat bottom of FIG. 2B is configured to contact a flat surface when in an upright configuration. The flat bottom depicted in FIG. 2B is smooth without any seams or film pinched together. FIG. 2B also depicts that each of the corners is unobstructed such that product added to the pouch will more easily be removed from the pouch and not trapped in the corners.

[0036] As shown in FIG. 2B, the interior gusset 122 divides the stand-up flexible pouch 110 into two compartments or chambers 126a, 126b. The interior gusset 122 is joined along its general periphery to the first body panel 112 and the second body panel 114. The interior gusset 122 is joined to the bottom gusset 120. The interior gusset 122 is shown as being connected or joined to the top portion 140 so as to define the two fully separated compartments 126a, 126b inside the stand-up flexible pouch 110. The interior gusset 122 is located between the first side gusset 116 and the second side gusset 118. The interior gusset 122 is configured to assist in preventing or inhibiting leakage of the contents between the respective compartments 126a, 126b of the stand-up flexible pouch 110. The two or more compartments may be of a similar size such as shown in FIG. 2B. In another embodiment, the compartments of a stand-up flexible pouch are of different sizes.

[0037] As shown in FIG. 2B, the interior gusset 122 is typically joined to the first and second body panels 112, 114 and the bottom gusset 120 from an inside attachment position. This is

desirable to reduce or eliminate visible seaming on the exterior of the first and second body panels 112, 114, although some weld lines may be observable.

[0038] Referring to FIGS. 3A and 3B, a two-compartment stand-up flexible pouch 210 is shown according to another embodiment. The stand-up pouch 210 includes a first or front body panel 212 (FIG. 3A only), a second or back body panel 214 (FIG. 3B), two side gussets 216, 218, a bottom gusset 220, a plurality of interior gussets 222, 224 (FIG. 3B only) and a top portion 240. FIG. 3B depicts the two-compartment stand-up flexible pouch 210 without the first body panel 212 to expose an interior of the pouch including the interior gussets 222, 224. The first body panel 212, the second body panel 214, the two side gussets 216, 218 and the bottom gusset 220 function similarly to that described above in the first body panel 112, the second body panel 114, the two side gussets 116, 118 and the bottom gusset 120, respectively.

[0039] The interior gussets 222, 224 shown in FIG. 3B are adjacent and parallel to each other. In this embodiment, interior gussets 222, 224 have a narrow space 228 therebetween. It is contemplated that the interior gussets may be located immediately adjacent to each other with no space therebetween.

[0040] Each of the interior gussets 222, 224 is joined to the first body panel 212 and the second body panel 214. Each of the interior gussets 222, 224 is typically joined to the bottom gusset 220. As shown in FIG. 3B, the interior gussets 222, 224 are shown as being connected or joined to the top portion 240 so as to define two fully separated compartments or chambers 226a, 226b within the stand-up flexible pouch 210.

[0041] The arrangement of the interior gussets 222, 224 is desirable because it offers better separation between compartments, especially in the event that one of the two interior gussets 222, 224 is pierced, broken or has not been sealed properly to one of the surfaces.

[0042] Referring back to FIGS. 2A, 2B, the top portion 140 of the stand-up flexible pouch 110 forms hanging apertures or holes 142a, 142b. The hanging apertures or holes 142a, 142b assist in hanging the stand-up flexible pouch 110 in a peg display in retail stores. In such an embodiment, the hanging apertures or holes 142a, 142b are sized for placement onto the pegs.

[0043] It is contemplated that the stand-up flexible pouch may form a convenient handle to make it easier for consumers to carry the stand-up pouch with product. The handle of the stand-up flexible pouch may include one large opening that enables an entire hand to enter and subsequently assist in lifting the stand-up flexible pouch to be lifted. In another embodiment, the handle may include a plurality of finger holes to assist in lifting the stand-up

pouch. It is also contemplated that straps and/or handles may be formed or attached to the stand-up flexible pouch at suitable locations to assist in lifting the stand-up pouch.

[0044] The stand-up flexible pouches of the present invention can be formed or fitted with various types of openings and closures. For example, the top portion 140 of the stand-up pouch 110 includes a line of weakness 144. The line of weakness desirably extends across the entire length of the stand-up flexible pouch such as shown in FIG. 2B. Referring to FIGS. 2A and 2B, each edge of the top portion has an inwardly-extending notch 144a, 144b to assist a user in accessing the line of weakness 144 that assists in removing a portion of the stand-up pouch.

[0045] The line of weakness 144 may be tear notches, pre-perforated tear strips, tear lines/strips. These lines of weakness may also be referred to as scored lines. The line of weakness is a feature typically located at the top portion to assist a user in opening the stand-up flexible pouch. It is also contemplated that the stand-up flexible pouch may be opened by cutting a top portion thereof in another embodiment.

[0046] The top portion may include a feature to open and close the stand-up flexible pouch. For example, the top portion 140 of the stand-up flexible pouch 110 includes a resealable fastener or zipper 146. The fastener 146 is attached between the first and second body panels 112, 114. The fastener 146 of FIGS. 2A, 2B extends generally across the opening of the stand-up pouch. As shown in FIG. 2B, the side gussets 116, 118 extend up from the bottom of the pouch 110 and terminate before the fastener 146. The fastener 146 may include a slider that is slidably mounted thereto to facilitate opening and closing of the fastener. This type of closure is desirable to implement when it is important to keep contents as fresh as possible after initially opening the stand-up flexible pouch. Other types of closures that may be used with the stand-up flexible pouches include, but are not limited to, hook and loop seals, adhesive or magnetic closures.

[0047] Referring back to FIGS. 3A, 3B, the top portion 240 of the stand-up flexible pouch 210 forms hanging apertures or holes 242a, 242b that are similar to the apertures 142a, 142b described above. The top portion 240 includes a line of weakness 244 and a plurality of fasteners 246a, 246b. The line of weakness 244 is similar to the line of weakness 144 described above. The fasteners 246a, 246b of FIGS. 3A, 3B are similar to the fastener 146, except fasteners 246a, 246b only extend partially across the stand-up flexible pouch 210. Each of the fasteners 246a, 246b enables access to a respective individual compartment 226a, 226b of the stand-up flexible pouch 210. As shown in FIG. 3B, the side gussets 216, 218 extend up from the bottom of the pouch 210 and terminate before the fasteners 246a, 246b.

[0048] Referring now to FIG. 3C, the stand-up pouch 210 of FIGS. 3A, 3B is shown with a line of weakness 260 in another embodiment. The line of weakness 260 assists in separating the compartments or chambers 226a, 226b (FIG. 3B) into two separate and distinct pouches after the section 238 has been removed via the line of weakness 244. The lines of weakness 260 extends from the line of weakness 244 down the front body panel 212 and around the bottom gusset 220 and around the second body panel 214 up to the line of weakness 244. It is contemplated that the line of weakness may extend fully through section 238 to edge 262 such that the stand-up flexible pouch may be separated into two pouches before opening.

[0049] The stand-up flexible pouches of the present invention may be fitted with one or more translucent or see-through windows, which are desirably positioned on the first or second body panels. The at least one window is desirably configured such that at least one if not each individual inner compartment may be viewed. For example, each of the compartments may be visible through a respective window that enables the respective contents to be seen by a user. This is shown in FIG. 4 in one embodiment.

[0050] FIG. 4 depicts a stand-up flexible pouch 310 that is substantially similar to the stand-up pouch 210 described above. The stand-up pouch 310, however, includes a first or front body panel 312 that includes a plurality of generally rectangular windows 350a, 350b that allow a user to view the respective contents in each of the compartments. It is noted that the first body panel may include only one window. It is also contemplated that the windows may be shaped and sized different than the two generally rectangular windows 350a, 350b shown in FIG. 4. It is contemplated that the other stand-up flexible pouches of the present invention may include at least one window to assist in viewing the contents of the respective compartments. The windows 350a, 350b may be made of a translucent material. One non-limiting example for forming the windows is polyvinylidene chloride (PVDC). It is, however, contemplated that other materials may be used in forming the at least one window.

[0051] In addition to or instead of the above described openings and closures, the stand-up pouches of the present invention may be fitted with various types of pouring and/or dispensing mechanisms. Some non-limiting examples of pouring and/or dispensing mechanisms include, but are not limited to, spouts for liquids (with or without re-sealable caps), swing-out spouts for flowing powders, pump heads and/or trigger spray heads. It is contemplated that other pouring or dispensing mechanisms may be used in the stand-up flexible pouches of the present invention.

[0052] One non-limiting example of a stand-up flexible pouch with a pouring or dispensing mechanism is shown in FIG. 5. FIG. 5 depicts a stand-up flexible pouch 410 that is

substantially similar to the stand-up flexible pouch 210. The stand-up flexible pouch 410, however, includes a first body panel 412 having a plurality of pouring or dispensing mechanism 470a, 470b to assist in removing the contents from respective compartments. It is noted that the stand-up flexible pouch may include exactly one pouring mechanism, although, if used, two pouring mechanisms are often preferred. It is also contemplated that the pouring or dispensing mechanism may be different than that shown in FIG. 5. It is contemplated that the pouring or dispensing mechanism may be located in different positions than shown in FIG. 5. It is contemplated that the other stand-up flexible pouches of the present invention may include at least one pouring or dispensing mechanism.

[0053] It is desirable for each compartment in the stand-up pouches of the present invention to have its own individual opening, closure, pouring and/or dispensing mechanism. But, it is contemplated that in other embodiments that the stand-up pouches may be fitted with just one common opening, closure, pouring and/or dispensing mechanism.

[0054] The stand-up flexible pouches of the present invention may be designed for mixing together the contents of its various inner compartments before use or dispensing (e.g., by providing a mechanism for breaking or piercing the interior gusset(s) before dispensing the contents out of the pouch). For example, the stand-up flexible pouches may include an internal valve that breaks or bursts in response to a user's pressure on the pouch. This breaking or bursting results in the different products of the compartments intermixing with each other. It is contemplated that other mechanisms may be used in the stand-up flexible pouches of the present invention.

[0055] It is contemplated that the stand-up flexible pouch may include more than two compartments for storing product. For example, the stand-up flexible pouch may include three compartments formed by two spaced apart interior gussets or two pairs of spaced apart interior gussets.

[0056] One non-limiting example of a three compartment stand-up flexible pouch is shown in FIGS. 6A and 6B. FIG. 6A shows a three compartment stand-up flexible pouch 510 with a first or front body panel 512, while FIG. 6B shows the stand-up flexible pouch 510 without the first body panel 512. The stand-up flexible pouch 510 includes the first or front body panel 512 (FIG. 6A only), a second or back body panel 514 (FIG. 6B), two side gussets 516, 518, a bottom gusset 520, and a plurality of interior gussets 522, 524, 532, 534 (FIG. 6B) and a top portion 540. As shown in FIG. 6B, the bottom gusset 520 extends between the first and second side gussets 516, 518. The interior gussets 522, 524, 532, 534 divide the stand-up pouch 510 into three compartments 526 a-c. As shown in FIG. 6B, the interior gussets 522

and 524 have a space 528a therebetween, while the interior gussets 532 and 534 have a space 528b therebetween. It is contemplated that the interior gussets may be immediately adjacent to each other with little or no space therebetween.

[0057] As shown in FIG. 6B, the bottom gusset 520 is configured to form a flat bottom in an upright configuration. The flat bottom extends between the first and second body panels 512, 514. The flat bottom further extends between the first and second side gussets 516, 518. The flat bottom has an interior surface and an exterior surface. The entire exterior surface of the flat bottom of FIG. 6B is configured to contact a flat surface when in an upright configuration. The flat bottom depicted in FIG. 6B is smooth and without any seams or film pinched together. FIG. 6B also depicts that each of the corners is unobstructed such that product added to the pouch will more easily be removed from the pouch and not trapped in the corners.

[0058] The top portion 540 of the stand-up pouch 510 further forms hanging apertures 542a, 542b, a line of weakness 544 and includes fasteners 546a-c, which are similar to the above described hanging apertures, line of weaknesses and the fasteners. As shown in FIG. 6B, the first and second side gussets 516, 518 extend up from the bottom of the pouch 510 and terminate before the fasteners 546a-c. The stand-up flexible pouch 510 also includes windows 550a-c and lines of weakness 560a, 560b as shown in FIG. 6A that extend generally from the bottom pouch 520 to a top edge 562 of the top portion 540. The lines of weakness 560a, 560b extend from the top edge 562 all around the first body panel 512, the bottom gusset 520 and the second body panel 514. The lines of weakness 560a, 560b assist in separating the stand-up pouch 510 into three separate pouches if desired. The lines of weaknesses 560a, 560b can separate the stand-up pouch 510 into three separate pouches before opening the stand-up flexible pouch 510.

[0059] It is contemplated that a three compartment stand-up flexible pouch may be made from exactly two interior gussets.

[0060] It is contemplated that the number of compartments may be greater than the 2 or 3 shown in the non-limiting embodiments described above. For example, a stand-up flexible pouch may include 4, 5, 6 or even more compartments. It is contemplated that the compartments may have a similar or the same amount of interior space such as shown in FIG. 6B. In other embodiments, the compartments of the stand-up pouches are of different sizes.

[0061] The stand-up flexible pouches of the present invention may be made with suitable materials. In one embodiment, the stand-up flexible pouches comprise a polymer material. Some non-limiting example of polymeric materials that may be used in forming the stand-up

flexible pouches include linear low density polyethylene (LLDPE), low density polyethylene (LDPE), metallocene-catalyzed linear low density polyethylene (mLLDPE), polyesters (e.g., polyethylene terephthalate (PET)), nylon, and combinations thereof. It is contemplated that other polymeric materials may be used. The polymeric materials selected are typically heat-sealable polymeric materials.

[0062] The stand-up flexible pouches of the present invention may be made of PVC (polyvinyl chloride) in a further embodiment. Such an embodiment typically uses a double-sided adhesive in constructing the stand-up flexible pouches.

[0063] The stand-up flexible pouches may comprise a single material or may comprise a plurality of materials. For example, the plurality of materials may be in a blended composition or a laminate. One non-limiting example of a flexible laminate material is a metallized PET. One non-limiting example of a metallized PET is aluminum and PET. Another embodiment is a metallized polyethylene such as a metallized LLDPE. It is desirable for the laminated polymeric material to be of a high grade that lends itself to custom printing. The stand-up flexible pouches may be made of other polymeric materials, polymeric composites and laminates, metal foil or combinations thereof.

[0064] The stand-up flexible pouches may also be made of biodegradable materials such as heat-sealable sugar cane. The stand-up flexible pouches may be made of other materials such as non-wovens. Although less desirable, it is contemplated that the stand-up flexible pouches may be made of materials such as cardboard, paper, rubber sheets and cloth in other embodiments.

[0065] It is contemplated that the above described materials may be used in various combinations in forming the stand-up flexible pouches. With regard to size, shape and dimensions, the stand-up flexible pouches of the present invention may be manufactured in various sizes and shapes suitable for storage, transport or retail selling.

[0066] It is contemplated that the stand-up flexible pouches may include an oxygen-barrier material. The oxygen-barrier material may be added as a separate layer or may be integrated within a material. The oxygen-barrier layer may be formed by materials that assist in preventing or inhibiting oxygen from entering the stand-up flexible pouch. These materials may include, but are not limited to, ethylene vinyl alcohol (EVOH). It is contemplated that other oxygen-barrier materials may be used in forming the stand-up flexible pouch.

[0067] The multi-compartment stand-up flexible pouches of the present invention may be used for convenient packaging of any type of suitable content including commercial or industrial products. The product may be in the form of dry powders, granular products,

flowable solids, liquids, paste, gases, etc. Typical non-limiting examples of such products are: sports/nutrition, pharmaceuticals, cosmetics, beverages, foodstuffs, baby food, household (cleaners, detergents, softeners), dairy, pet food and motor oil. It is contemplated that other commercial or industrial products may be used in the stand-up flexible pouches of the present invention.

[0068] Due to the convenient combination of the at least two separate compartments within one single pouch, the stand-up pouch is uniquely suited for packaging and selling combos of two or more products that are normally sold together. These two or more products are typically used around the same time, mixed together at the point of use, or are combined in certain ratios and dosages.

[0069] Non-limiting examples of products include, but are not limited to: (1) shampoo and conditioner; (2) detergent and softener, detergent and bleach, or detergent and stain pre-treatment; (3) pre-workout and post-workout sport supplements; (4) combos of multi-flavored food or sport supplements or pet food; (5) fertilizer and pesticide, or seed and fertilizer; (6) milk and cereal, milk and cookies, or other matching snacks; (7) multi-component products that are supposed to be mixed together just before use (e.g. cake mixes, beverage mixes, two-component adhesives, effervescent mixes, powdered or concentrated baby formula with water, reactive components, base resin and activator, car engine oil, fuel and transmission oil additives, etc.); or (8) various small parts or components within the same kit, which desirably should not come in contact with each other before final assembly.

[0070] In one method, the various components used in forming the multi-compartment stand-up flexible pouch are heated sealed with each other. The heat sealing may be performed by heating or ultrasonic sealing. The stand-up pouches may be formed by other methods such as chemical bonding. It is contemplated that other methods of attaching the various components of the stand-up flexible pouch may be employed.

[0071] According to one process, a flexible film may be used for forming the first and second body panels of the stand-up flexible pouch. The film may be a single layer film or a multi-layered film such as discussed above. The first and second body panels may be formed from separate individual films, but are typically formed from one individual film sheet. The side and interior gusset-forming materials are made separately from the body panels. The side and interior gusset-forming materials are located in the interior of the film that is to eventually form the first and second body panels. The gussets are typically heat-sealed to respective interior surfaces of the film that will eventually form the first and second body panels.

[0072] One non-limiting example of a process for forming a stand-up flexible pouch is shown in FIGS. 7A-7C. This process will be described as forming a two compartment stand-up flexible pouch with one interior gusset. Referring initially to FIG. 7A, a film 604 is shown with a first side 604a and a second side 604b. The film 604 may be a single layer film or a multi-layered film as discussed above. The film 604 for forming the first and second sides 604a, 604b may be formed from one individual sheet that has been folded. If a single sheet is used for eventually forming the first and second body panels, the bottom gusset-forming material is typically formed from the same sheet by folding. Thus, this embodiment has a continuous first body panel, second body panel, and bottom-forming material, which results in a flat bottom in an upright configuration. The flat bottom is formed without seams or film being pinched together. It is contemplated that the bottom gusset-forming material may be formed separately from the first and second sides and later joined.

[0073] In another embodiment, the film 604 may be made of two separate individual films that are sealed together. In this embodiment, the bottom gusset-forming material may be formed separately from the first and second sides and later joined. In another embodiment, the bottom gusset-forming material is formed from the sheets after they have been sealed together.

[0074] To show the placement of interior gusset-forming material and side gusset-forming material with respect to the film 604, a plurality of bottom gusset-forming material 620a-c is depicted as being a transparent film. The pouch-forming material includes the bottom gusset-forming material 620a-c, side gusset-forming material 616a-d, and interior gusset-forming material 622a-c. The bottom gusset-forming material 620a-c extends or bridges the material that will eventually form the first and second body panels of a stand-up flexible pouch. The interior gusset-forming material 622a-c and the side gusset-forming material 616a-d are located between the first side 604a and the second side 604b of the film 604. The film 604 has an open end (end opposite from the bottom gusset-forming material 620a-c) that will eventually form a top portion of the stand-up flexible pouch. To form the stand-up flexible pouches shown above, the interior gusset-forming material 622a-c and the side gusset-forming material 616a-d will not extend vertically across the film to the opening end. Thus, the length of the interior gusset-forming material 622a-c and the side gusset-forming material 616a-d will be less than length L of the film 604. The gussets may be located in-line or across the web direction (such as shown in FIG. 7A).

[0075] The film 604 depicts a plurality of generally vertical lines 606a, 606b extending across the film. These vertical lines 606a, 606b indicate where the film 604 will be

eventually cut in the process of forming the stand-up flexible pouches. The cutting may be done by a reciprocating knife or other cutting mechanisms. The cutting mechanism may also perform simultaneously heat sealing with respect to the side gusset-forming material and the film.

[0076] Referring to FIG. 7B, a cutting mechanism 608 with reciprocating knives 608a, 608b is shown cutting the film 604. The cutting mechanism is typically an integrated device. The cutting mechanism 608 will cut the film 604 that eventually forms a two compartment stand-up flexible pouch of the present invention. It is contemplated that the cuts may be performed by separate mechanisms in other methods.

[0077] The side gusset-forming material 616a-d is joined to the first and second sides 604a, 604b. The side gusset-forming material is also typically joined to the bottom gusset-forming material. The interior gusset-forming material 622a-c is also joined to the first and second sides 604a, 604b. The interior gusset-forming material is also typically joined to the bottom gusset-forming material. This joining of the side and interior gusset-forming materials to the first and second sides may be done as discussed above by techniques such as sealing or bonding.

[0078] In one method, the sealing of the side and interior gusset-forming materials occurs before the cutting of the first and second sides 604a, 604b. In another method, the sealing of the side and interior gusset-forming materials occurs after cutting the first and second sides 604a, 604b. In a further method, the cutting and sealing occurs at about the same time.

[0079] After the pouch-forming material is cut and joined (e.g., sealed), a stand-up flexible pouch is formed. FIG. 7C shows an enlarged bottom perspective view of a stand-up flexible pouch 610. The stand-up flexible pouch 610 includes a first or front body panel 612, a second or back body panel 614, side gussets 616, 618, a bottom gusset 620 and an interior gusset 622. The stand-up flexible pouch 610 includes two compartments. As mentioned above, the bottom gusset 620 is shown as being transparent so that the side gusset 616 and the interior gusset 622 can be seen.

[0080] As shown in FIG. 7C, the bottom gusset 620 is configured to form a flat bottom. The flat bottom extends between the first and second body panels 612, 614. The flat bottom further extends between the first and second side gussets 616, 618. The flat bottom has an interior surface and an exterior surface. The entire exterior surface of the flat bottom of FIG. 7C is configured to contact a flat surface when in an upright configuration. The flat bottom depicted in FIG. 7C is smooth and without seams or film pinched together. FIG. 7C also

depicts that each of the corners is unobstructed such that product added to the pouch will more easily be removed from the pouch and not trapped in the corners.

[0081] Another non-limiting example of a process for forming a stand-up flexible pouch is shown in FIGS. 8A-8C. This process will be described as forming a three compartment stand-up flexible pouch with two interior gussets. Referring initially to FIG. 8A, a film 704 is shown with a first side 704a and a second side 704b. The film 704 for forming the first and second sides 704a, 704b may be formed from one individual sheet that has been folded. If a single sheet is used for eventually forming the first and second body panels, the bottom gusset-forming material is typically formed from the same sheet by folding. It is contemplated that the bottom gusset-forming material may be formed separately from the first and second sides and later joined.

[0082] In another embodiment, the film 704 may be made of two separate individual films that are sealed together. In this embodiment, the bottom gusset-forming material may be formed separately from the first and second sides and later joined. In another embodiment, the bottom gusset-forming material is formed from the sheets after they have been sealed together.

[0083] To show the placement of interior gusset-forming material and side gusset-forming material with respect to the film 704, a plurality of bottom gusset-forming material 720a-c is depicted as being a transparent film. The pouch-forming material includes the bottom gusset-forming material 720a-c, side gusset-forming material 716a-d and interior gusset-forming material 722a-f. The bottom gusset-forming material 720a-c extends or bridges the material that will eventually form the first and second body panels of a stand-up flexible pouch. The interior gusset-forming material 722a-f and the side gusset-forming material 716a-d are located between the first side 704a and the second side 704b of the film 704. The film 704 has an open end (end opposite from the bottom gusset-forming material 720a-c) that will eventually form a top portion of the stand-up flexible pouch. To form the stand-up flexible pouches shown above, the interior gusset-forming material 722a-f and the side gusset-forming materials 716a-d will not extend vertically across the film to the opening end. Thus, the length of the interior gusset-forming material 722a-f and the side gusset-forming materials 716a-d will be less than length L2 of the film 704. The gussets may be located in-line or across the web direction (such as shown in FIG. 8A).

[0084] The film 704 depicts a plurality of generally vertical lines 706a, 706b extending across. These vertical lines 706a, 706b indicate where the film 704 will be eventually cut in the process of forming the stand-up flexible pouches. As discussed above, the cutting may be

done by a reciprocating knife or other cutting mechanisms that may also perform simultaneously heat sealing with respect to the side gusset-forming material and the film.

[0085] Referring to FIG. 8B, a cutting mechanism 708 with reciprocating knives 708a, 708b is shown cutting the film 704. The cutting mechanism is typically an integrated device. The cutting mechanism 708 will cut the film 704 that eventually forms a three compartment stand-up flexible pouch of the present invention. It is contemplated that the cut may be performed by separate mechanisms in other embodiments.

[0086] The side gusset-forming material 716a-d is joined to the first and second sides 704a, 704b. The side gusset-forming material is also typically joined to the bottom gusset-forming material. The interior gusset-forming material 722a-f is also joined to the first and second sides 704a, 704b. The interior gusset-forming material is also typically joined to the bottom gusset-forming material. This joining of the side and interior gusset-forming materials to the first and second sides may be done as discussed above by techniques such as sealing or bonding.

[0087] In one method, the sealing of the side and interior gusset-forming materials occurs before the cutting of the first and second sides 704a, 704b. In another method, the sealing of the side and interior gusset-forming materials occurs after cutting the first and second sides 704a, 704b. In a further method, the cutting and sealing occurs at about the same time.

[0088] After the pouch-forming material is cut and joined (e.g., sealed), a stand-up flexible pouch is formed. FIG. 8C shows an enlarged bottom perspective view of a stand-up flexible pouch 710. The stand-up flexible pouch 710 includes a first or front body panel 712, a second or back body panel 714, side gussets 716, 718, a bottom gusset 720 and a plurality of interior gussets 722, 724. The stand-up flexible pouch 710 includes three compartments. As mentioned above, the bottom gusset 720 is shown as being transparent so that the side gusset 716 and the interior gussets 722, 724 can be seen.

[0089] As shown in FIG. 8C, the bottom gusset 720 is configured to form a flat bottom. The flat bottom extends between the first and second body panels 712, 714. The flat bottom further extends between the first and second side gussets 716, 718. The flat bottom has an interior surface and an exterior surface. The entire exterior surface of the flat bottom of FIG. 8C is configured to contact a flat surface when in an upright configuration. The flat bottom depicted in FIG. 8C is smooth without any seams or film pinched together.

If used in either of the processes described above with respect to FIGS. 7A-C and 8A-C, the features of the top portion such as fasteners, line of weakness, hanging apertures etc. are inserted or formed using known techniques in the art. The line of weakness and hanging

apertures are typically formed in-line using a punching device. The fasteners are typically inserted and heat sealed to an interior of the first and second body panels. Also, if used, windows may be formed by having the film with selected areas of different material that allow for viewing of the product.

[0090] The pouches may be formed using a horizontal pouch-forming process or a vertical pouch-forming process.

[0091] In another method, the stand-up pouches may be manufactured by joining together two or more single-compartment pouches. This is less desirable because it results in a visible exterior seam where the joining occurs, but otherwise still exhibits the advantages of the present invention.

[0092] While the foregoing written description of the invention enables one of ordinary skill to make and use what is considered presently to be the best mode thereof, those of ordinary skill will understand and appreciate the existence of variations, combinations, and equivalents of the specific embodiment, method, and examples herein. The invention should therefore not be limited by the above described embodiment, method, and examples, but by all embodiments and methods within the scope and spirit of the invention.

CLAIMS

WHAT IS CLAIMED IS:

1. A gusseted stand-up flexible pouch comprising:

a pouch-forming structure including first and second opposing body panels, first and second opposing side gussets, a bottom gusset and at least one interior gusset, the bottom gusset extending between the first body panel and the second body panel, each of the first and second side gussets being joined to the first body panel and the second body panel, the at least one interior gusset being joined to the first body panel and the second body panel, the at least one interior gusset being located between the first side gusset and the second side gusset,

wherein the at least one interior gusset divides an interior of the stand-up flexible pouch into a plurality of compartments.

2. A gusseted stand-up flexible pouch comprising:

a pouch-forming structure including first and second opposing body panels, first and second opposing side gussets, a bottom gusset and at least one interior gusset, the bottom gusset extending between the first body panel and the second body panel, the bottom gusset extending between the first and second side gussets, each of the first and second side gussets being joined to the first body panel and the second body panel, the at least one interior gusset being joined to the first body panel and the second body panel, the at least one interior gusset being located between the first side gusset and the second side gusset,

wherein the at least one interior gusset divides an interior of the stand-up flexible pouch into a plurality of compartments,

wherein the stand-up flexible pouch is configured to have the bottom gusset form a flat bottom in an upright configuration, the flat bottom extending between the first and second body panels, the flat bottom further extending between the first and second side gussets, the flat bottom having an interior surface and an exterior surface, the entire exterior surface of the flat bottom is configured to contact a flat surface when in an upright configuration.

3. The stand-up pouch of claim 1 or 2 further including a top portion opposite of the bottom gusset, the top portion including a recloseable zipper.

4. The stand-up pouch of claim 1 or 2 further including a top portion opposite of the bottom gusset, the top portion including a line of weakness.
5. The stand-up pouch of claim 1 or 2, further including a top portion opposite of the bottom gusset, the top portion forming a hanging aperture.
6. The stand-up pouch of claim 1 or 2 further including at least one pouring mechanism to assist in dispensing product from the stand-up pouch.
7. The stand-up pouch of claim 1 or 2, wherein the plurality of compartments is exactly two chambers.
8. The stand-up pouch of claim 1 or 2, wherein the stand-up flexible pouch has exactly one opening.
9. The stand-up pouch of claim 1 or 2, wherein each of the plurality of compartments has an individual opening.
10. The stand-up pouch of claim 1 or 2, wherein the stand-up flexible pouch comprises polymeric materials.
11. The stand-up pouch of claim 1 or 2, wherein the stand-up flexible pouch comprises a metallized polymeric material.
12. The stand-up pouch of claim 1 or 2, wherein the bottom gusset is integrally joined with the first and second body panels.
13. The stand-up pouch of claim 1 or 2, wherein the first and second side gussets are joined to the bottom gusset.
14. The stand-up pouch of claim 1 or 2, wherein the at least one interior gusset is joined to the bottom gusset.
15. A gusseted stand-up flexible pouch comprising:

a pouch-forming structure including first and second opposing body panels, first and second opposing side gussets, a bottom gusset and a plurality of interior gussets, the bottom gusset extending between the first body panel and the second body panel, each of the first and second side gussets being joined to the first body panel and the second body panel, each of the plurality of interior gussets being joined to the first body panel and the second body panel, each of the plurality of interior gussets being located between the first side gusset and the second side gusset,

wherein the plurality of interior gussets divides an interior of the stand-up pouch into a plurality of compartments.

16. A gusseted stand-up flexible pouch comprising:

a pouch-forming structure including first and second opposing body panels, first and second opposing side gussets, a bottom gusset and a plurality of interior gussets, the bottom gusset extending between the first body panel and the second body panel, the bottom gusset extending between the first and second side gussets, each of the first and second side gussets being joined to the first body panel and the second body panel, each of the plurality of interior gussets being joined to the first body panel and the second body panel, each of the plurality of interior gussets being located between the first side gusset and the second side gusset,

wherein the plurality of interior gussets divides an interior of the stand-up pouch into a plurality of compartments,

wherein the stand-up flexible pouch is configured to have the bottom gusset form a flat bottom in an upright configuration, the flat bottom extending between the first and second body panels, the flat bottom further extending between the first and second side gussets, the flat bottom having an interior surface and an exterior surface, the entire exterior surface of the flat bottom is configured to contact a flat surface when in an upright configuration.

17. The stand-up pouch of claim 15 or 16, wherein the plurality of interior gussets is exactly two interior gussets.

18. The stand-up pouch of claim 15 or 16, wherein the plurality of interior gussets is at least four interior gussets.

19. The stand-up pouch of claim 15 or 16, wherein the stand-up flexible pouch forms at least three compartments.

20. The stand-up pouch of claim 15 or 16 further including a top portion opposite of the bottom gusset, the top portion including a recloseable zipper and a line of weakness.

21. The stand-up pouch of claim 15 or 16 further including a top portion opposite of the bottom gusset, the top portion including at least two recloseable zippers and a line of weakness.

22. The stand-up pouch of claim 15 or 16, wherein the bottom gusset is integrally joined with the first and second body panels.

23. The stand-up pouch of claim 15 or 16, wherein the first and second side gussets are joined to the bottom gusset.

24. The stand-up pouch of claim 15 or 16, wherein the plurality of interior gussets is joined to the bottom gusset.

25. A gusseted stand-up flexible pouch comprising:
a pouch-forming structure including first and second opposing body panels, first and second opposing side gussets, a bottom gusset and at least one interior gusset, the bottom gusset extending between the first body panel and the second body panel, each of the first and second side gussets being joined to the first body panel and the second body panel, the at least one interior gusset being joined to the first body panel and the second body panel, the at least one interior gusset being located between the first side gusset and the second side gusset,

wherein the at least one interior gusset divides an interior of the stand-up flexible pouch into a plurality of compartments,

wherein the pouch-forming structure includes at least one line of a weakness, the at least one line of weakness extending from the first body panel around the bottom gusset and to the second body panel, the at least one line of weakness assisting in separating the pouch-forming structure into at least two separated pouches.

26. A gusseted stand-up flexible pouch comprising:

a pouch-forming structure including first and second opposing body panels, first and second opposing side gussets, a bottom gusset and at least one interior gusset, the bottom gusset extending between the first body panel and the second body panel, the bottom gusset extending between the first and second side gussets, each of the first and second side gussets being joined to the first body panel and the second body panel, the at least one interior gusset being joined to the first body panel and the second body panel, the at least one interior gusset being located between the first side gusset and the second side gusset,

wherein the at least one interior gusset divides an interior of the stand-up flexible pouch into a plurality of compartments,

wherein the pouch-forming structure includes at least one line of a weakness, the at least one line of weakness extending from the first body panel around the bottom gusset and to the second body panel, the at least one line of weakness assisting in separating the pouch-forming structure into at least two separated pouches,

wherein the stand-up flexible pouch is configured to have the bottom gusset form a flat bottom in an upright configuration, the flat bottom extending between the first and second body panels, the flat bottom further extending between the first and second side gussets, the flat bottom having an interior surface and an exterior surface, the entire exterior surface of the flat bottom is configured to contact a flat surface when in an upright configuration.

27. The stand-up pouch of claim 25 or 26, wherein the line of weakness extends from an edge of the first body panel to an edge of the second body panel.

28. The stand-up pouch of claim 25 or 26, wherein the at least one line of weakness is exactly one line of weakness.

29. The stand-up pouch of claim 25 or 26, wherein the pouch-forming structure includes a plurality of lines of a weakness, each of the plurality of lines of weakness extending from the first body panel around the bottom gusset and to the second body panel, the plurality of lines of weakness assisting in separating the pouch-forming structure into at least three separated pouches.

30. The stand-up pouch of claim 29, wherein each of the plurality of lines of weakness extends from an edge of the first body panel to an edge of the second body panel.

31. A method of forming a gusseted stand-up flexible pouch, the method comprising:

providing a sheet of film having a first side and a second side;

folding the sheet of film to form a bottom gusset, the sheet of film having an open end opposite of the bottom gusset;

placing a side gusset-forming material and interior gusset-forming material between the first and second sides of the sheet of film;

cutting the side gusset-forming material to form first and second side gussets;

sealing the first and second side gussets to interior surfaces of the first side and the second side;

sealing the interior gusset-forming material to interior surfaces of the first side and the second side to form at least one interior gusset,

wherein after the cutting and sealing, the at least one interior gusset divides an interior of the stand-up flexible pouch into a plurality of compartments.

32. The method of claim 31, wherein the stand-up flexible pouch is configured to have a bottom gusset form a flat bottom in an upright configuration, the flat bottom extending between the first and second body panels, the flat bottom further extending between the first and second side gussets, the flat bottom having an interior surface and an exterior surface, the entire exterior surface of the flat bottom is configured to contact a flat surface when in an upright configuration.

33. The method of claim 31 further including forming at least one line of a weakness, the at least one line of weakness extending from the first side around the bottom gusset and to the second side, and wherein the at least one line of weakness assists in separating the pouch-forming structure into at least two separated pouches.

34. The method of claim 31, 32 or 33, wherein the first and second sides of the film are integrally connected.

35. The method of claim 31, 32 or 33, wherein the first and second sides of the film are joined together.

36. The method of claim 31, 32 or 33 further including sealing the first and second side gussets to the bottom gusset.

37. The method of claim 31, 32 or 33 further including sealing the interior gusset-forming material to the bottom gusset.

38. A method of forming a gusseted stand-up flexible pouch, the method comprising:

providing a sheet of film having a first side and a second side;

folding the sheet of film to form a bottom gusset, the sheet of film having an open end opposite of the bottom gusset;

placing a first and a second side gusset-forming material between the first and second sides of the sheet of film;

placing a first and a second interior gusset-forming material between the first and second sides of the sheet of film;

cutting the first and second side gusset-forming material to form first and second side gussets;

sealing the first and second side gussets to interior surfaces of the first side and the second side;

sealing the first and second interior gusset-forming material to interior surfaces of the first side and the second side to form first and second interior gussets,

wherein after the cutting and sealing, the first and second interior gussets divide an interior of the stand-up flexible pouch into at least three compartments.

39. The method of claim 38, wherein the stand-up flexible pouch is configured to have a bottom gusset form a flat bottom in an upright configuration, the flat bottom extending between the first and second body panels, the flat bottom further extending between the first and second side gussets, the flat bottom having an interior surface and an exterior surface, the entire exterior surface of the flat bottom is configured to contact a flat surface when in an upright configuration.

40. The method of claim 38 further including forming at least one line of a weakness, the at least one line of weakness extending from the first side around the bottom gusset and to the second side, and wherein the at least one line of weakness assists in separating the pouch-forming structure into at least two separated pouches.

41. The method of claim 38, 39 or 40, further including placing at least a third interior gusset-forming material between the first and second sides of the sheet of film; and sealing the at least a third interior gusset-forming material to interior surfaces of the first side and the second side to form a third interior gusset, wherein after the cutting and sealing, the first, second and third interior gussets divide an interior of the stand-up flexible pouch into at least four compartments.

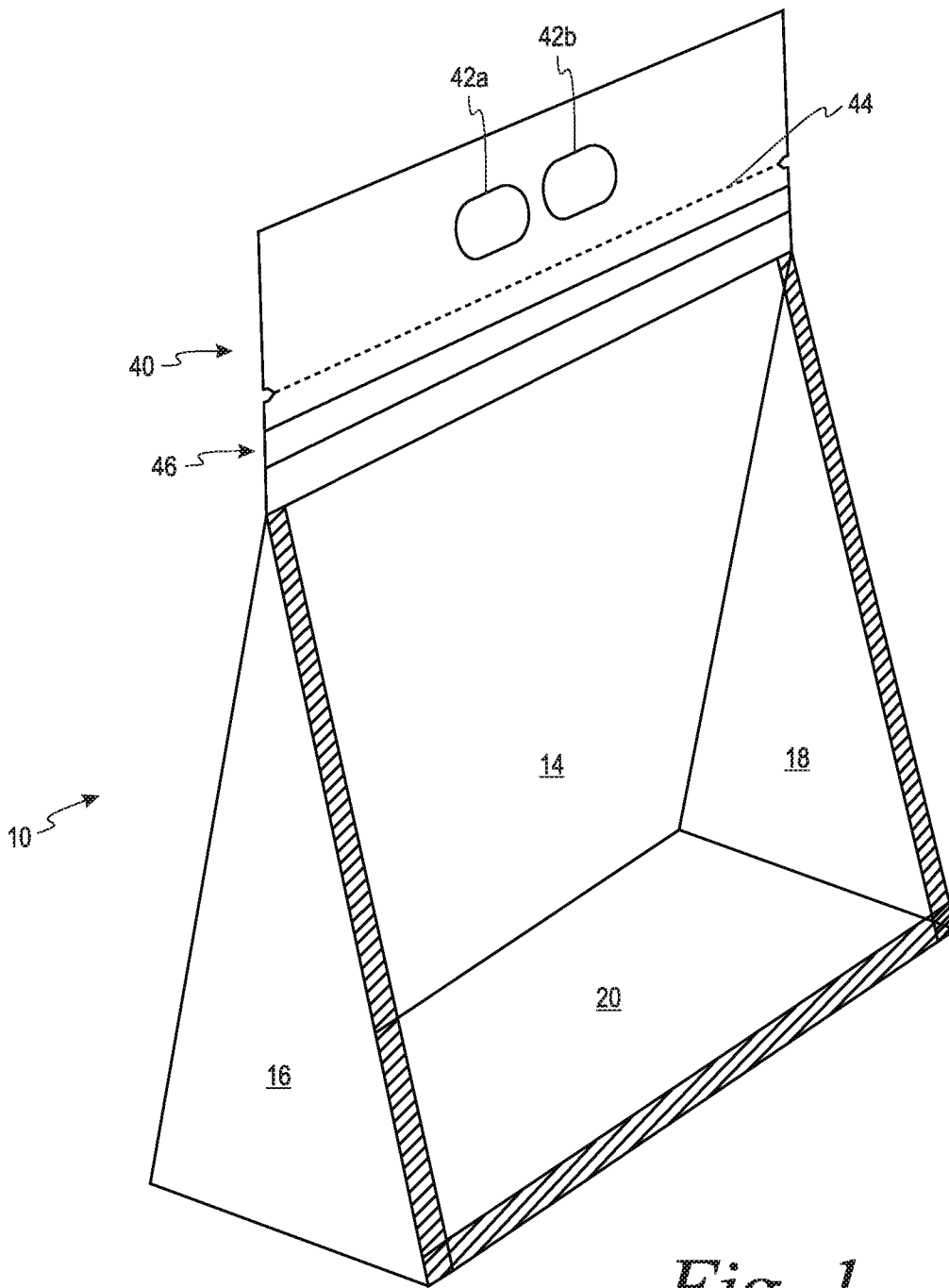

Fig. 1
PRIOR ART

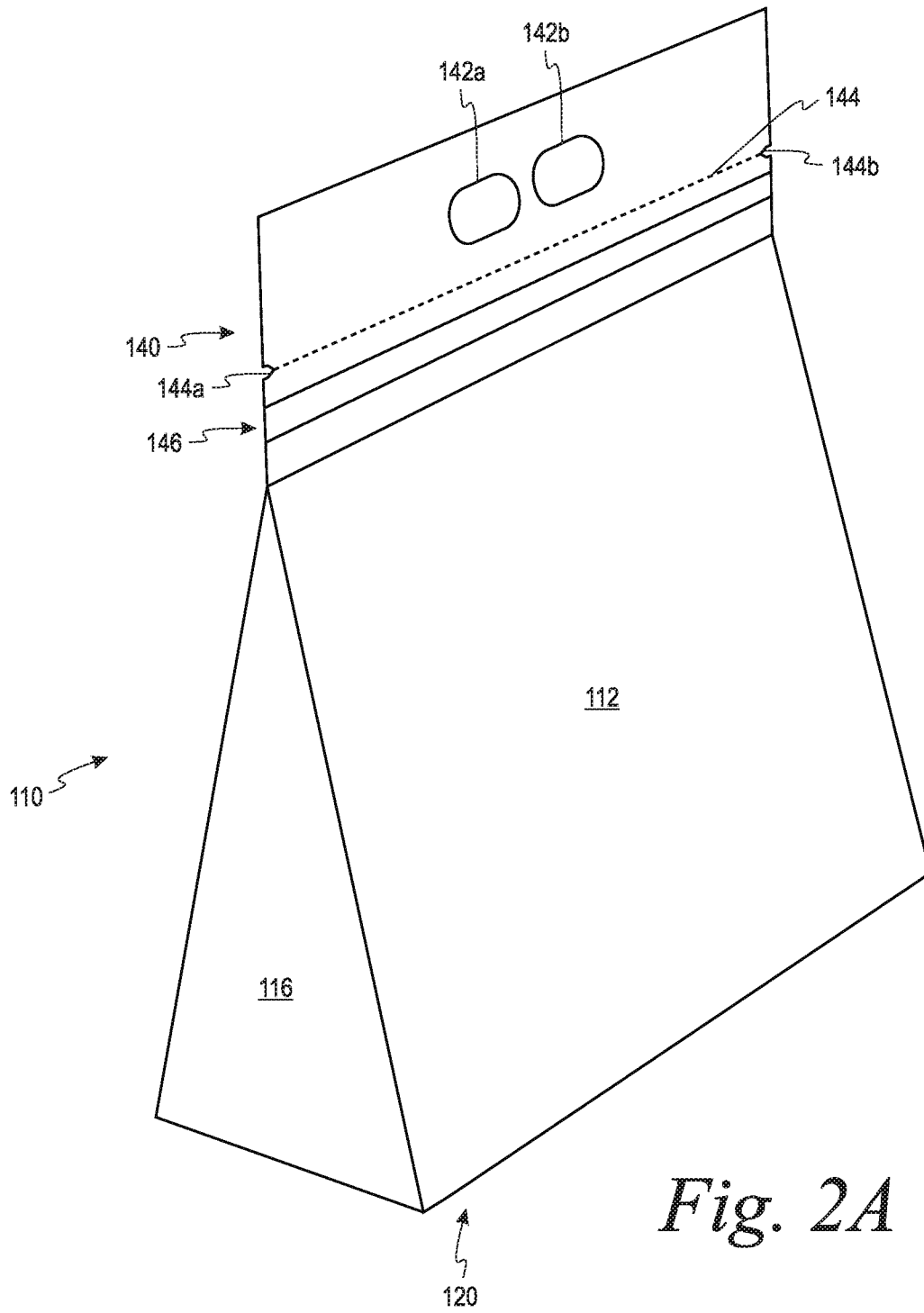

Fig. 2A

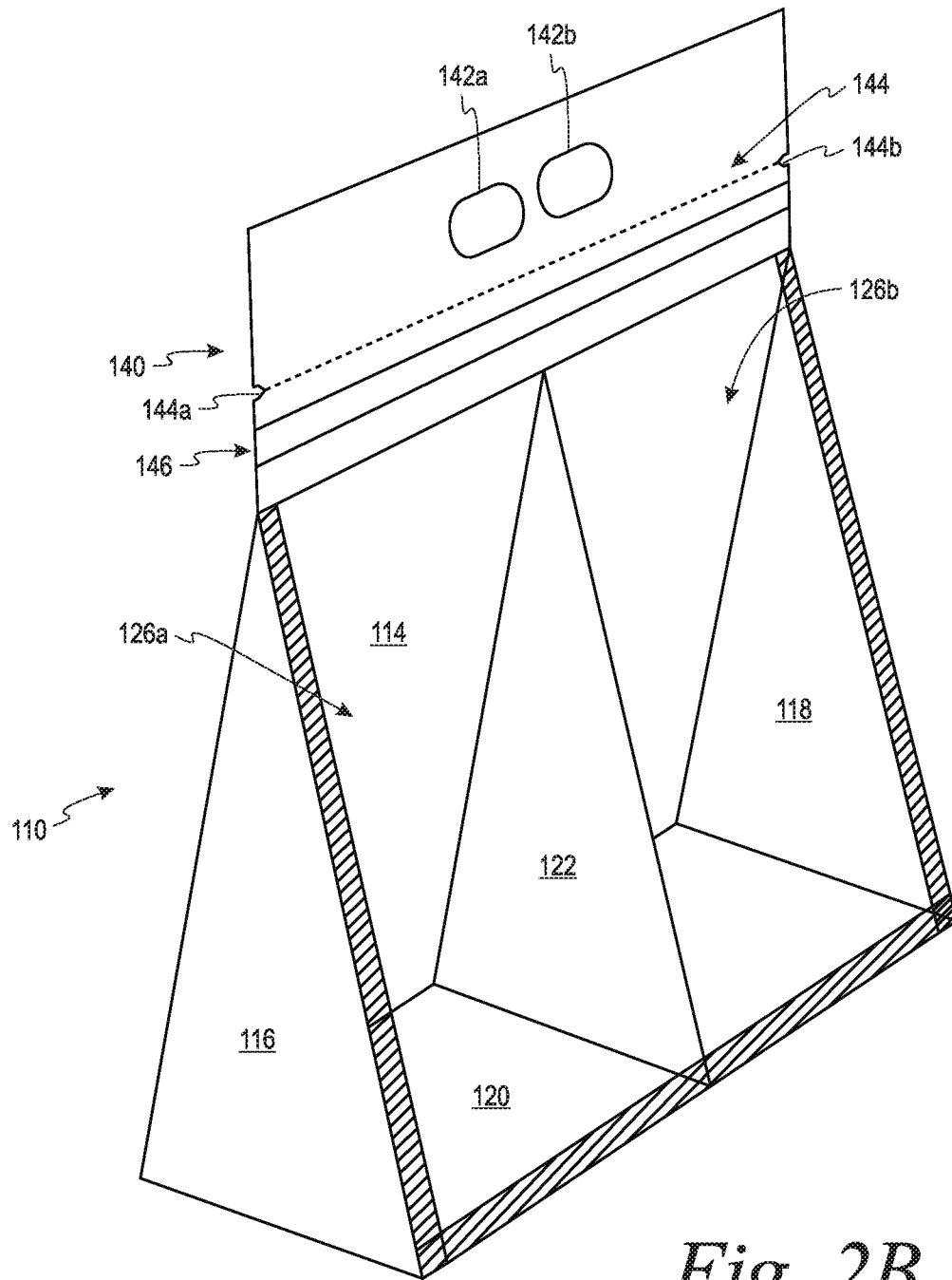
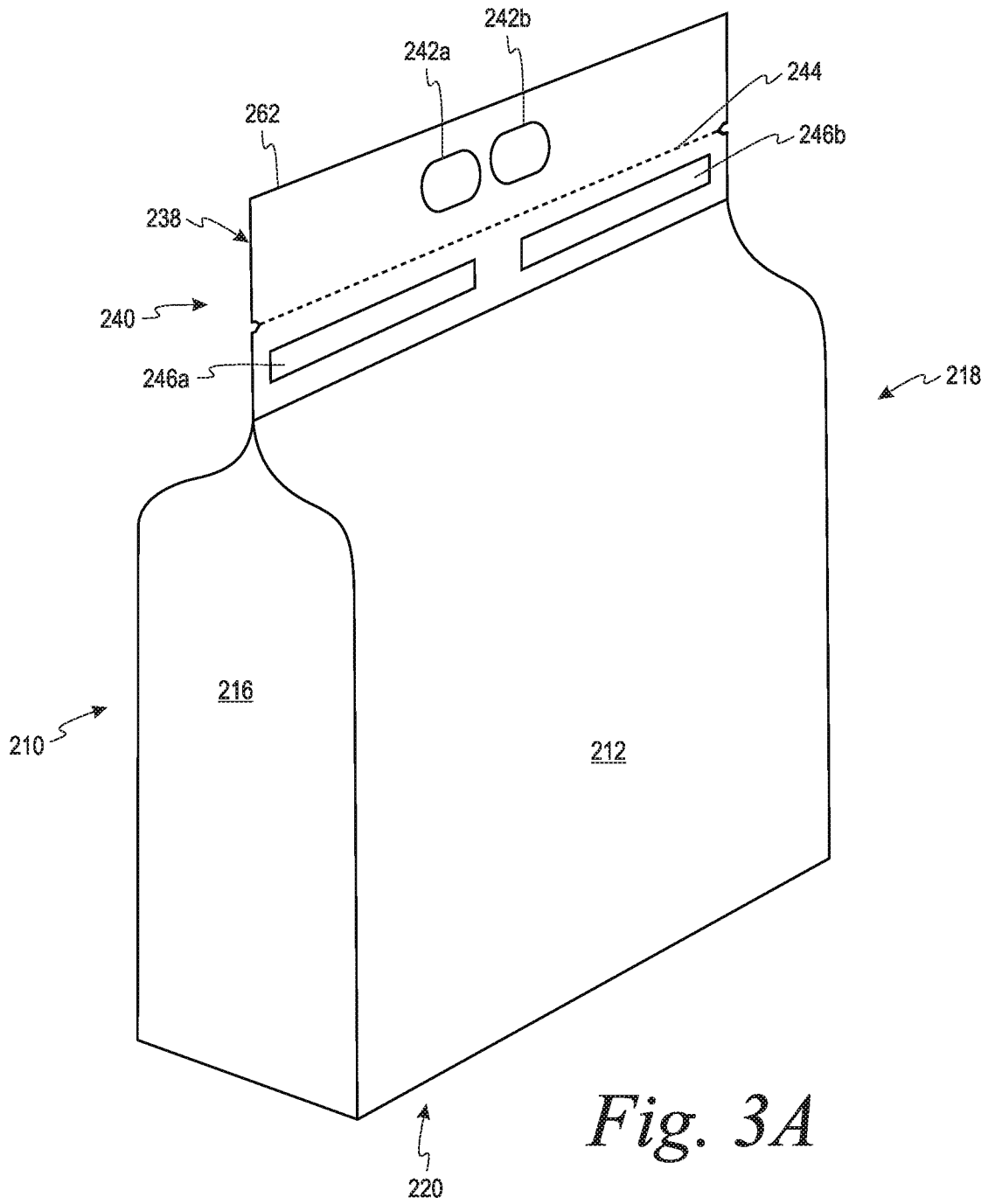

Fig. 2B



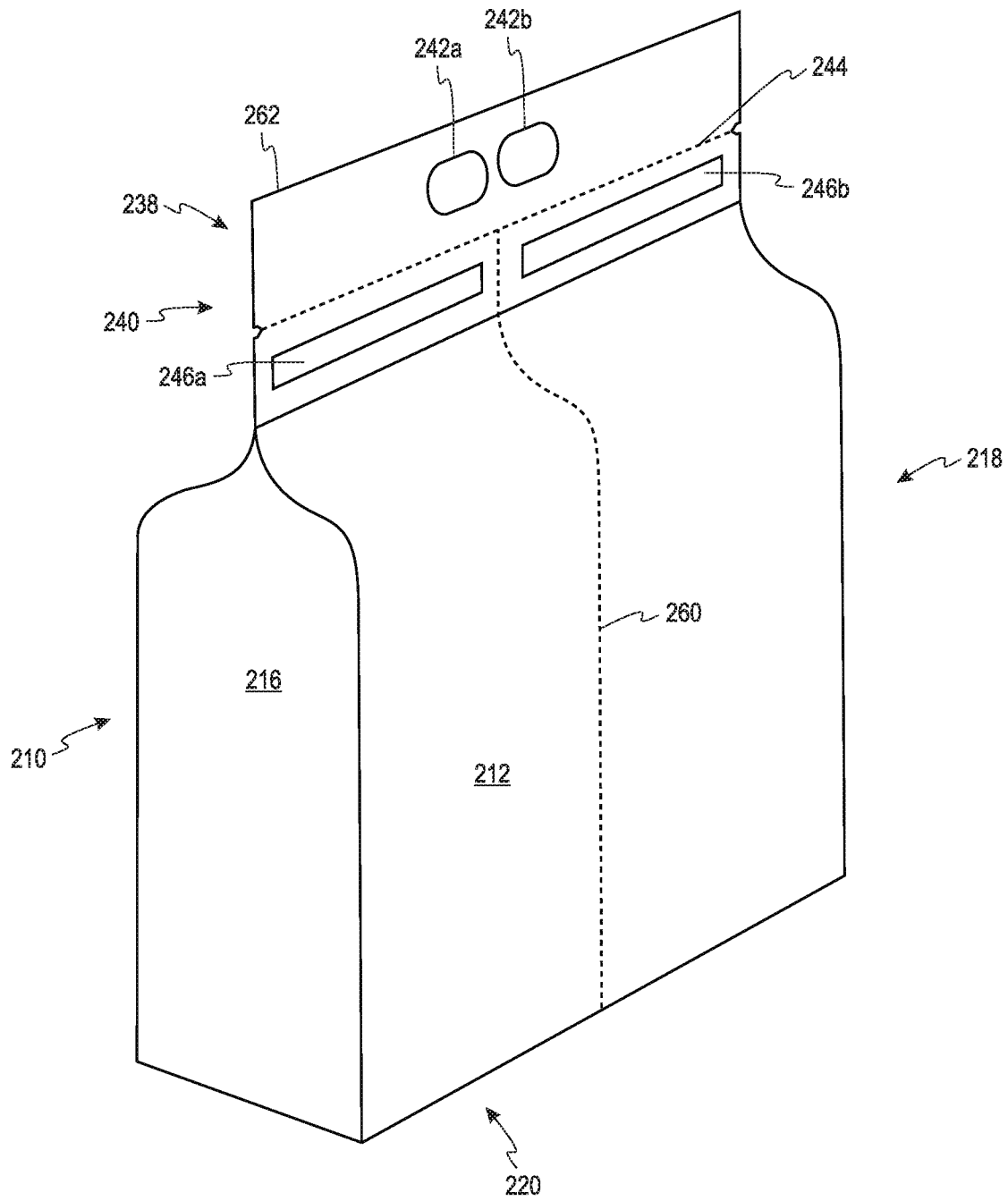

Fig. 3C

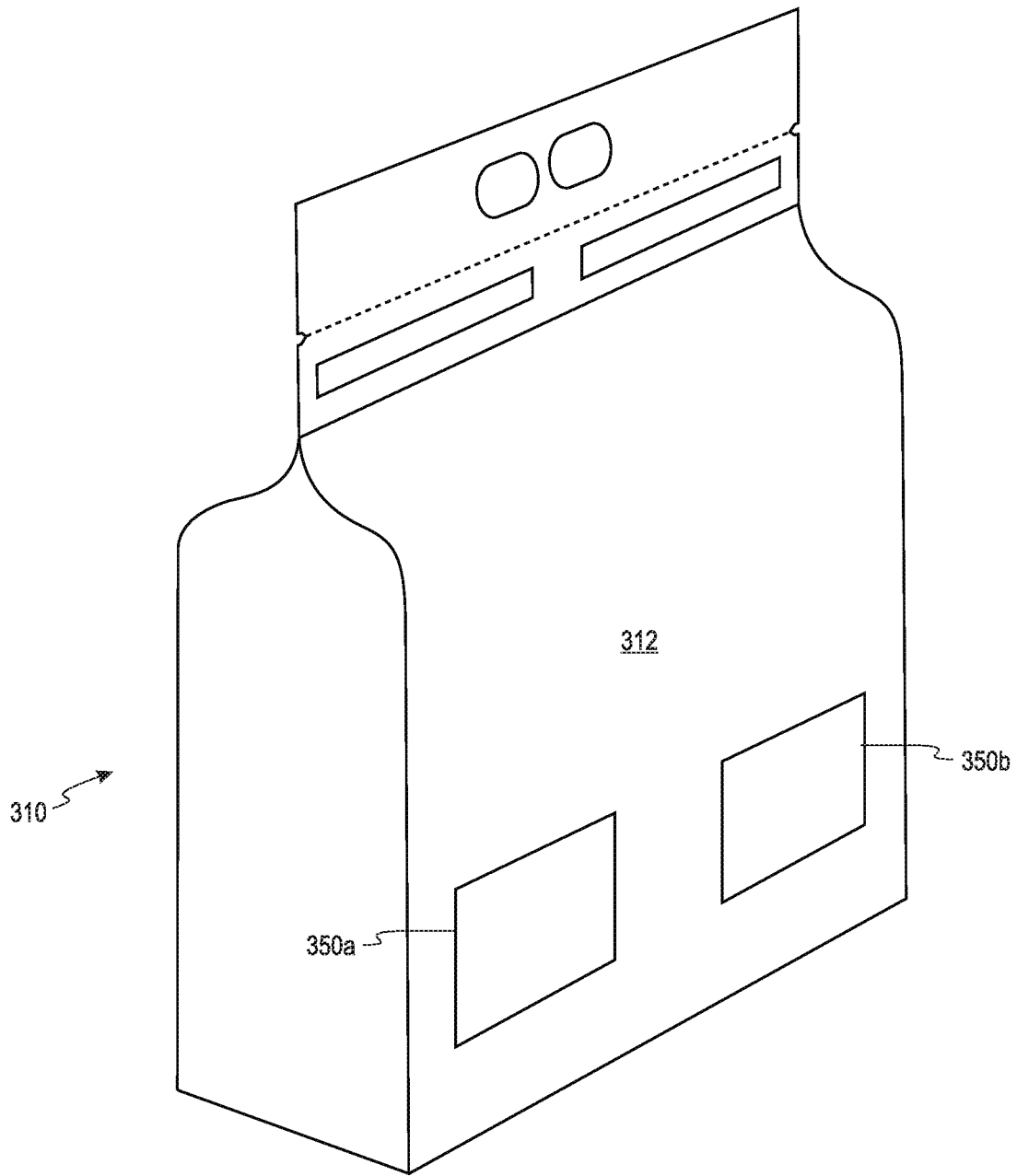

Fig. 4

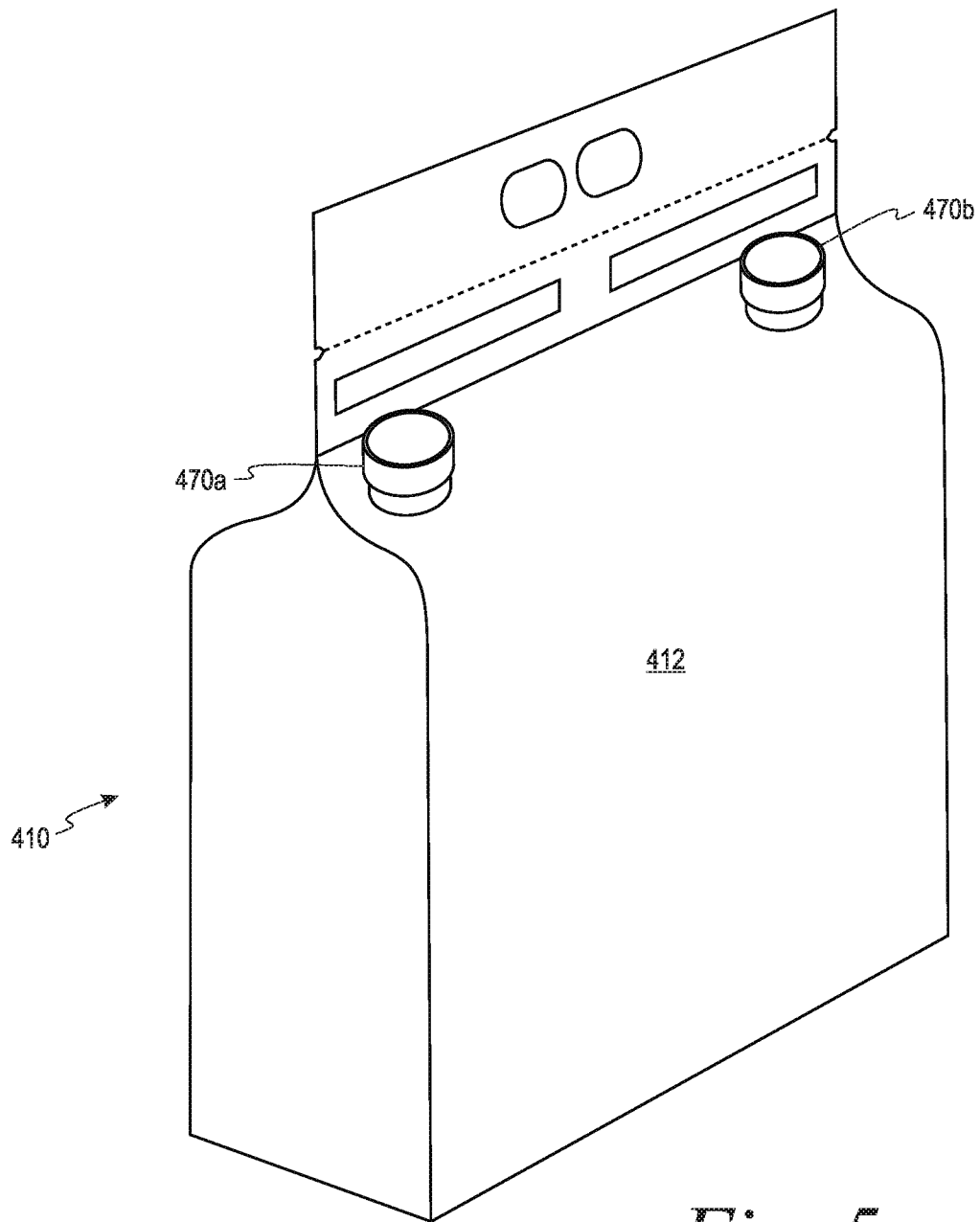

Fig. 5

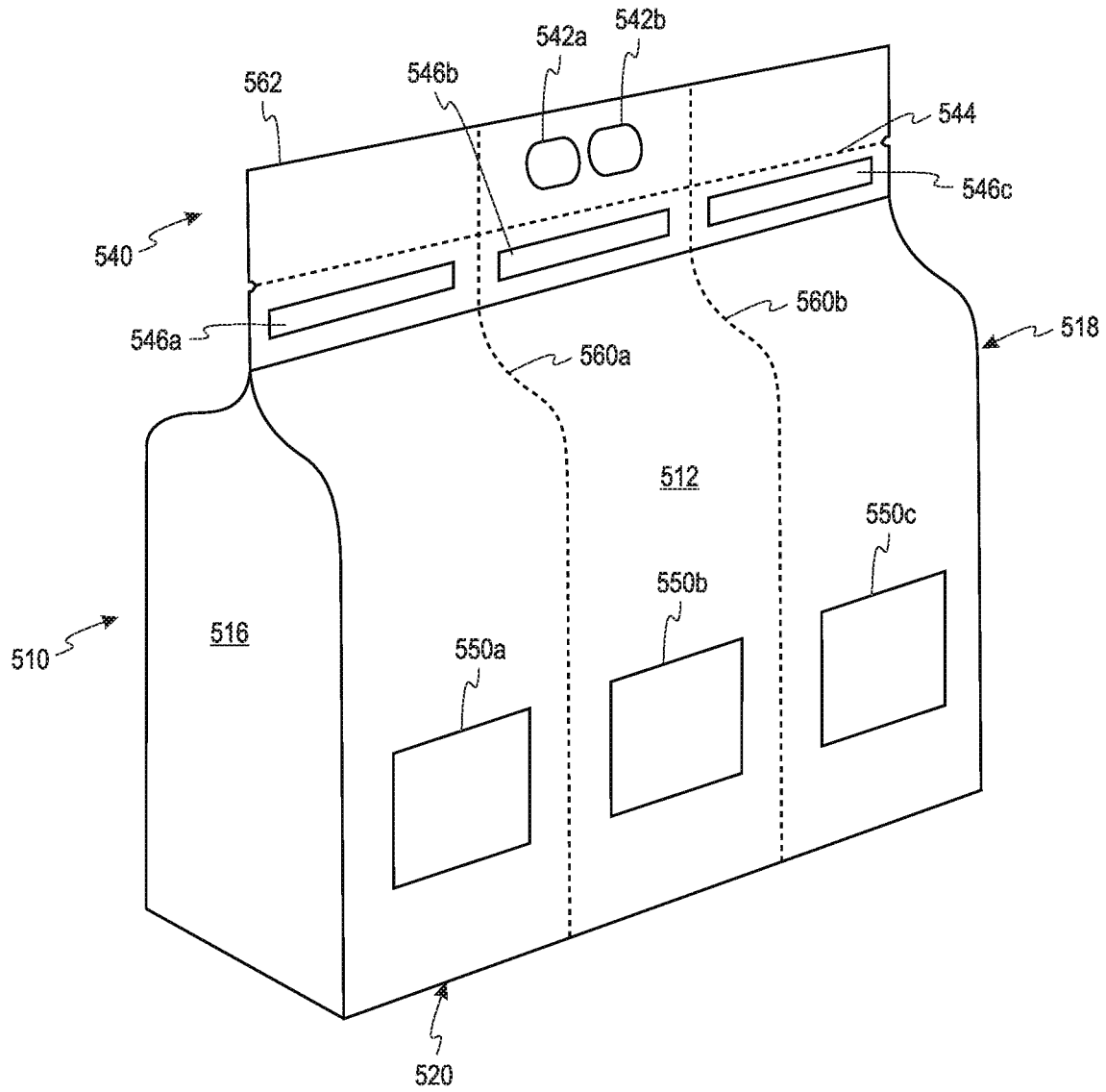

Fig. 6A

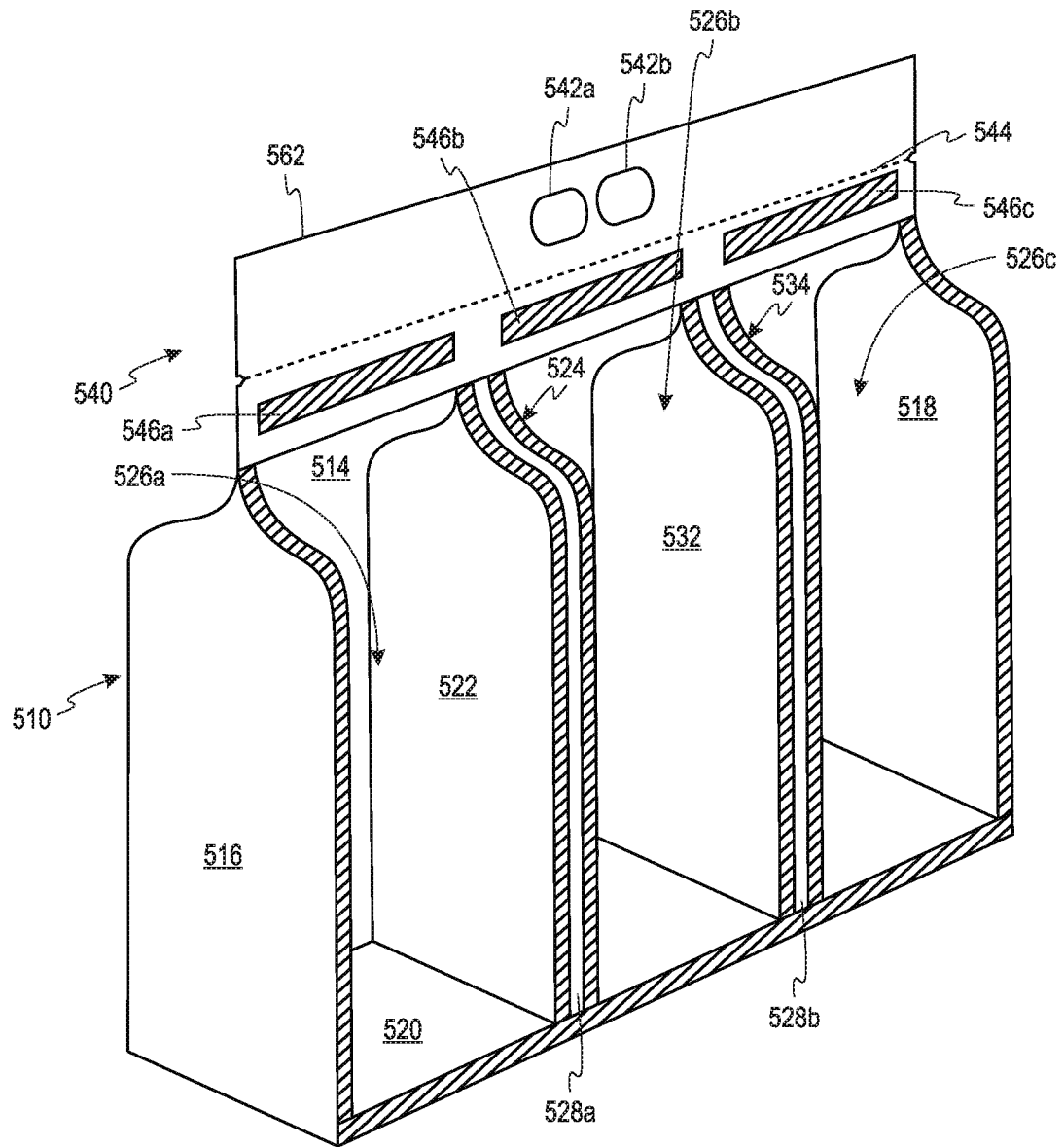
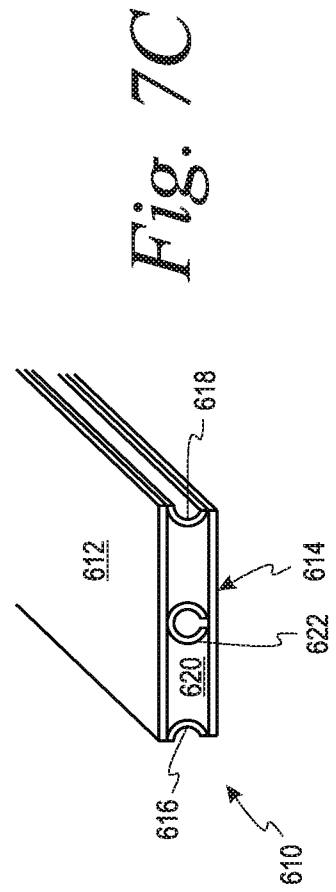
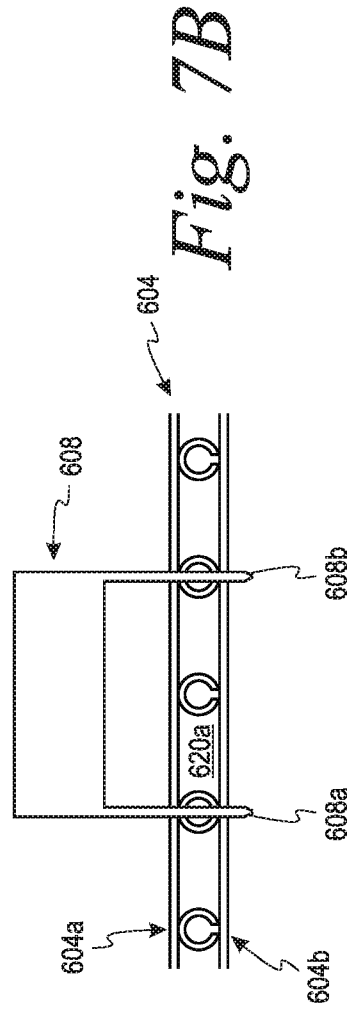
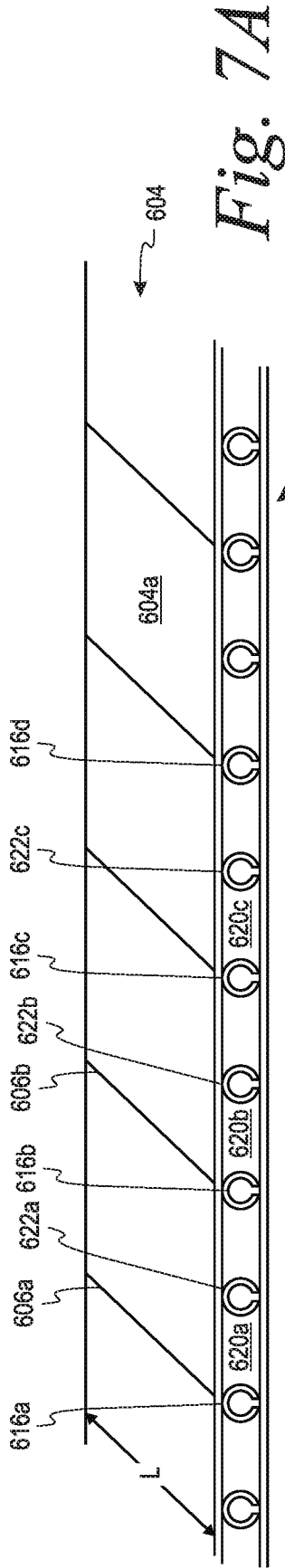
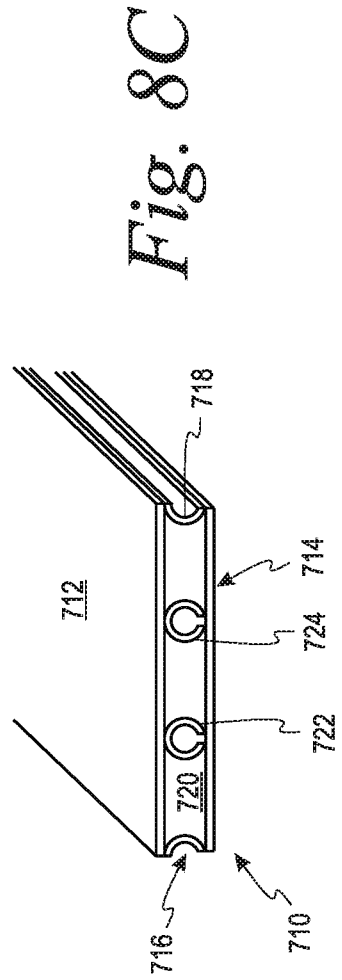
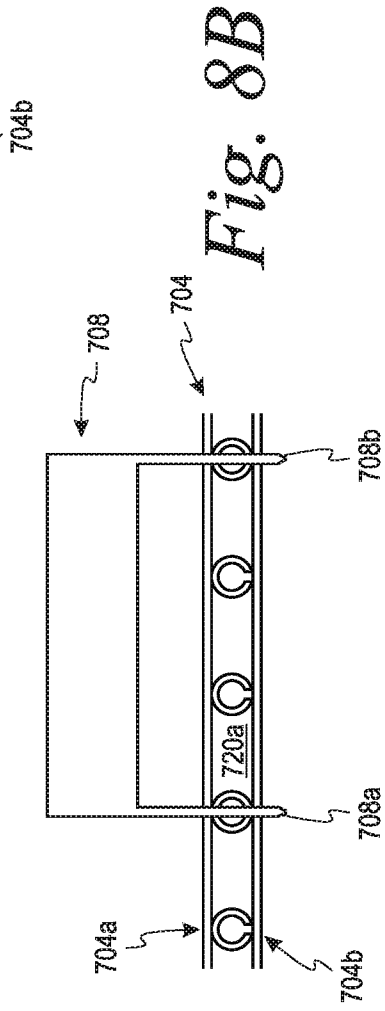
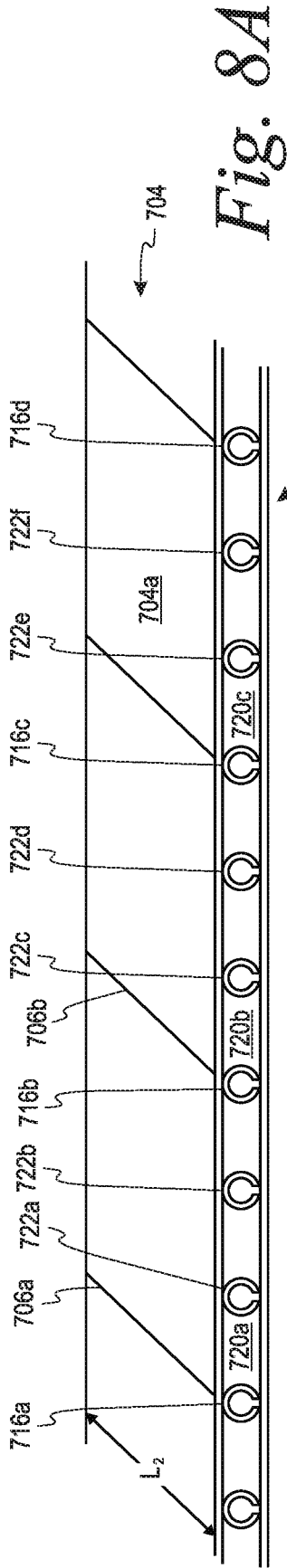

Fig. 6B





INTERNATIONAL SEARCH REPORT

International application No.

PCT/IB2019/053613

A. CLASSIFICATION OF SUBJECT MATTER
 IPC: *B65D 30/22* (2006.01), *B65D 30/28* (2006.01), *B65D 33/02* (2006.01)

According to International Patent Classification (IPC) or to both national classification and IPC

B. FIELDS SEARCHED

Minimum documentation searched (classification system followed by classification symbols)

IPC: *B65D 30/22* (2006.01), *B65D 30/28* (2006.01), *B65D 33/02* (2006.01), *B65D 30/16* (2006.01)

CPC: *B65D 33/008*

Documentation searched other than minimum documentation to the extent that such documents are included in the fields searched

None

Electronic database(s) consulted during the international search (name of database(s) and, where practicable, search terms used)

Questel Orbit (FAMPAT)

Keywords: *divid+*, *separate+*, *gusset+*, *pouch+*, *frangib+*, *weakness+*, *tear+*

C. DOCUMENTS CONSIDERED TO BE RELEVANT

Category*	Citation of document, with indication, where appropriate, of the relevant passages	Relevant to claim No.
X	JP 5519063 B1(SUGIMOTO, M.) 11 June 2014 (11-06-2014) * Abstract, figures *	1-24, 31, 32, 34-39, and 41
X	EP 2 332 853 A1 (OVERMÜLLER, E. et al.) 15 June 2011 (15-06-2011) * Entire document *	1-7, 9-11, 13-21, and 23-30
Y		12, 22, and 31-41
Y	US 2013/139473 A1 (BEER, J.) 06 June 2013 (06-06-2013) * Entire document *	12, 22, and 31-41
A	WO 2006/050748 A1 (MARINONI, S.) 18 May 2006 (18-05-2006) * Entire document	

Further documents are listed in the continuation of Box C.

See patent family annex.

* Special categories of cited documents:	"T" later document published after the international filing date or priority date and not in conflict with the application but cited to understand the principle or theory underlying the invention
"A" document defining the general state of the art which is not considered to be of particular relevance	"X" document of particular relevance; the claimed invention cannot be considered novel or cannot be considered to involve an inventive step when the document is taken alone
"D" document cited by the applicant in the international application	"Y" document of particular relevance; the claimed invention cannot be considered to involve an inventive step when the document is combined with one or more other such documents, such combination being obvious to a person skilled in the art
"E" earlier application or patent but published on or after the international filing date	"&" document member of the same patent family
"L" document which may throw doubts on priority claim(s) or which is cited to establish the publication date of another citation or other special reason (as specified)	
"O" document referring to an oral disclosure, use, exhibition or other means	
"P" document published prior to the international filing date but later than the priority date claimed	

Date of the actual completion of the international search
05 July 2019 (05-07-2019)

Date of mailing of the international search report
16 August 2019 (16-08-2019)

Name and mailing address of the ISA/CA
 Canadian Intellectual Property Office
 Place du Portage I, C114 - 1st Floor, Box PCT
 50 Victoria Street
 Gatineau, Quebec K1A 0C9
 Facsimile No.: 819-953-2476

Authorized officer

Daniel Rempel (819) 639-7893

INTERNATIONAL SEARCH REPORT
Information on patent family members

International application No.
PCT/IB2019/053613

Patent Document Cited in Search Report	Publication Date	Patent Family Member(s)	Publication Date
JP5519063B1	11 June 2014 (11-06-2014)	JP2015030231A	16 February 2015 (16-02-2015)
EP2332853A1	15 June 2011 (15-06-2011)	DE202009016721U1	21 April 2011 (21-04-2011)
US2013139473A1	06 June 2013 (06-06-2013)	US2017320632A1 WO2013085879A2 WO2013085879A3	09 November 2017 (09-11-2017) 13 June 2013 (13-06-2013) 08 August 2013 (08-08-2013)
WO2006050748A1	18 May 2006 (18-05-2006)	None	