

J. N. CHADWICK.  
 APPARATUS FOR CASTING BOMBS OR PROJECTILES  
 APPLICATION FILED JUNE 5, 1918.

1,298,176.

Patented Mar. 25, 1919.

4 SHEETS—SHEET I.

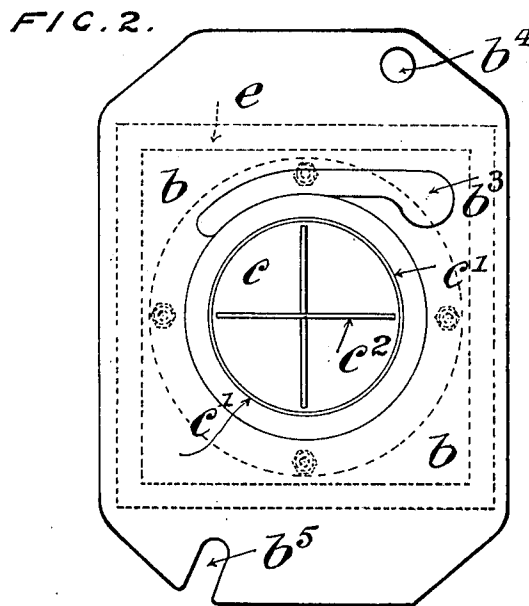
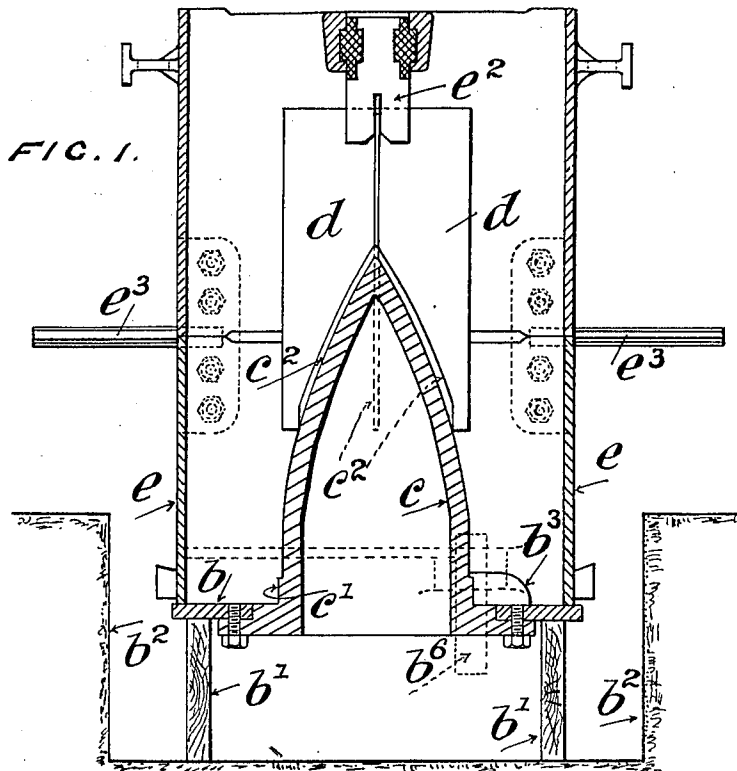

INVENTOR:  
 James Norman Chadwick  
 BY Mrs Wallace White  
 ATTY.

J. N. CHADWICK,  
 APPARATUS FOR CASTING BOMBS OR PROJECTILES.  
 APPLICATION FILED JUNE 5, 1918.

1,298,176.

Patented Mar. 25, 1919.

4 SHEETS—SHEET 2.

FIG. 3.

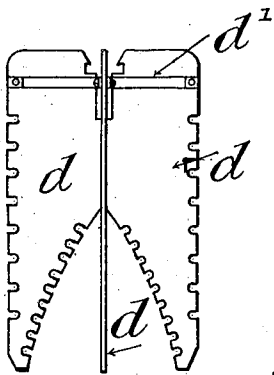

FIG. 4.

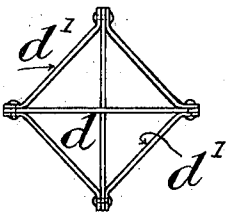

FIG. 5.

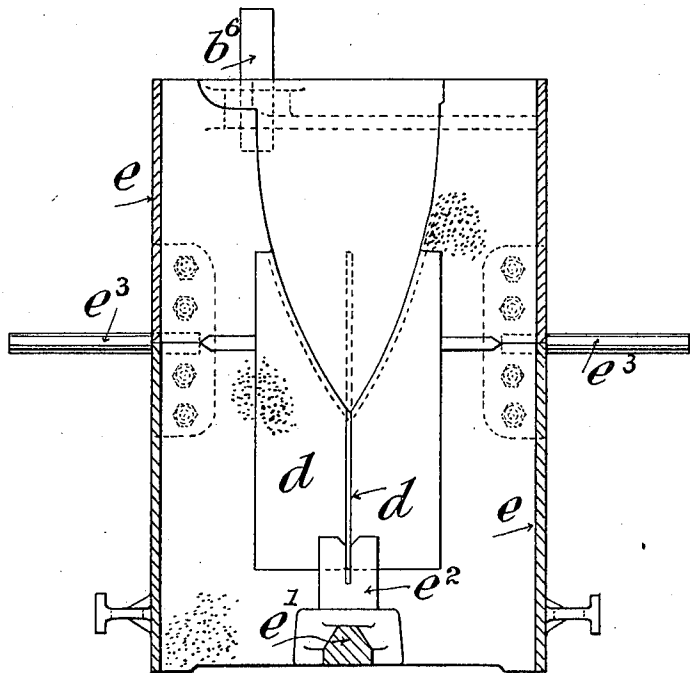
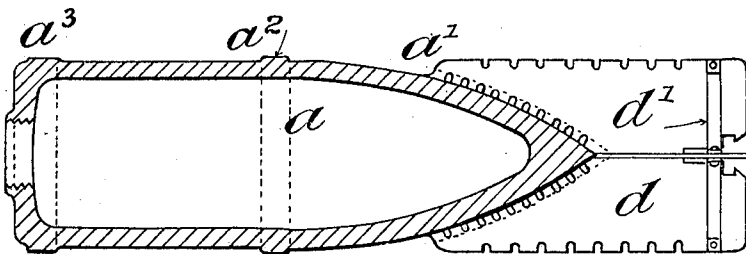

FIG. 6.



INVENTOR:  
*James Norman Chadwick*  
 BY *Wm Wallace White*  
 ATT'Y.

J. N. CHADWICK.  
 APPARATUS FOR CASTING BOMBS OR PROJECTILES.  
 APPLICATION FILED JUNE 5, 1918.

1,298,176.

Patented Mar. 25, 1919.

4 SHEETS—SHEET 3.

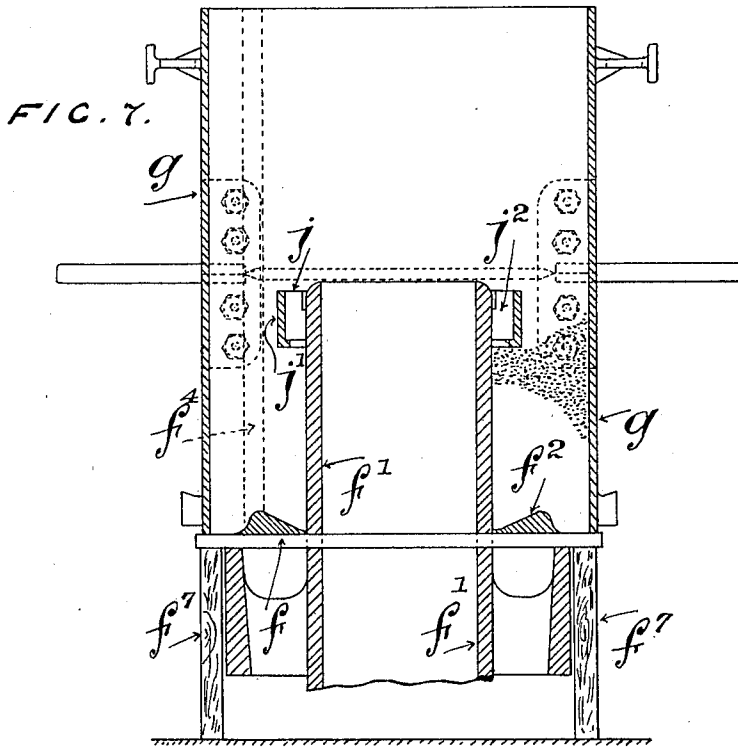
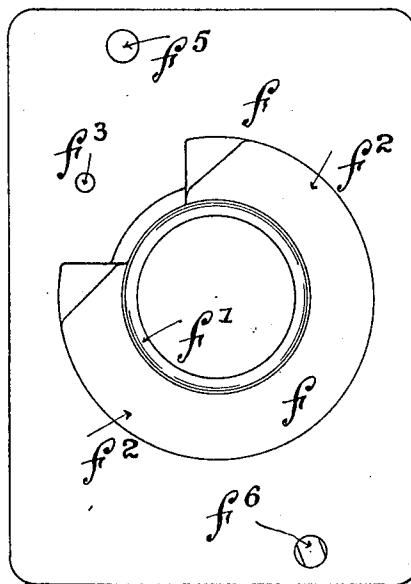

FIG. 8.



INVENTOR:  
 James N. Chadwick  
 BY *Wm Wallace White*  
 ATTY

J. N. CHADWICK.  
 APPARATUS FOR CASTING BOMBS OR PROJECTILES.  
 APPLICATION FILED JUNE 5, 1918.

1,298,176.

Patented Mar. 25, 1919.

4 SHEETS—SHEET 4.

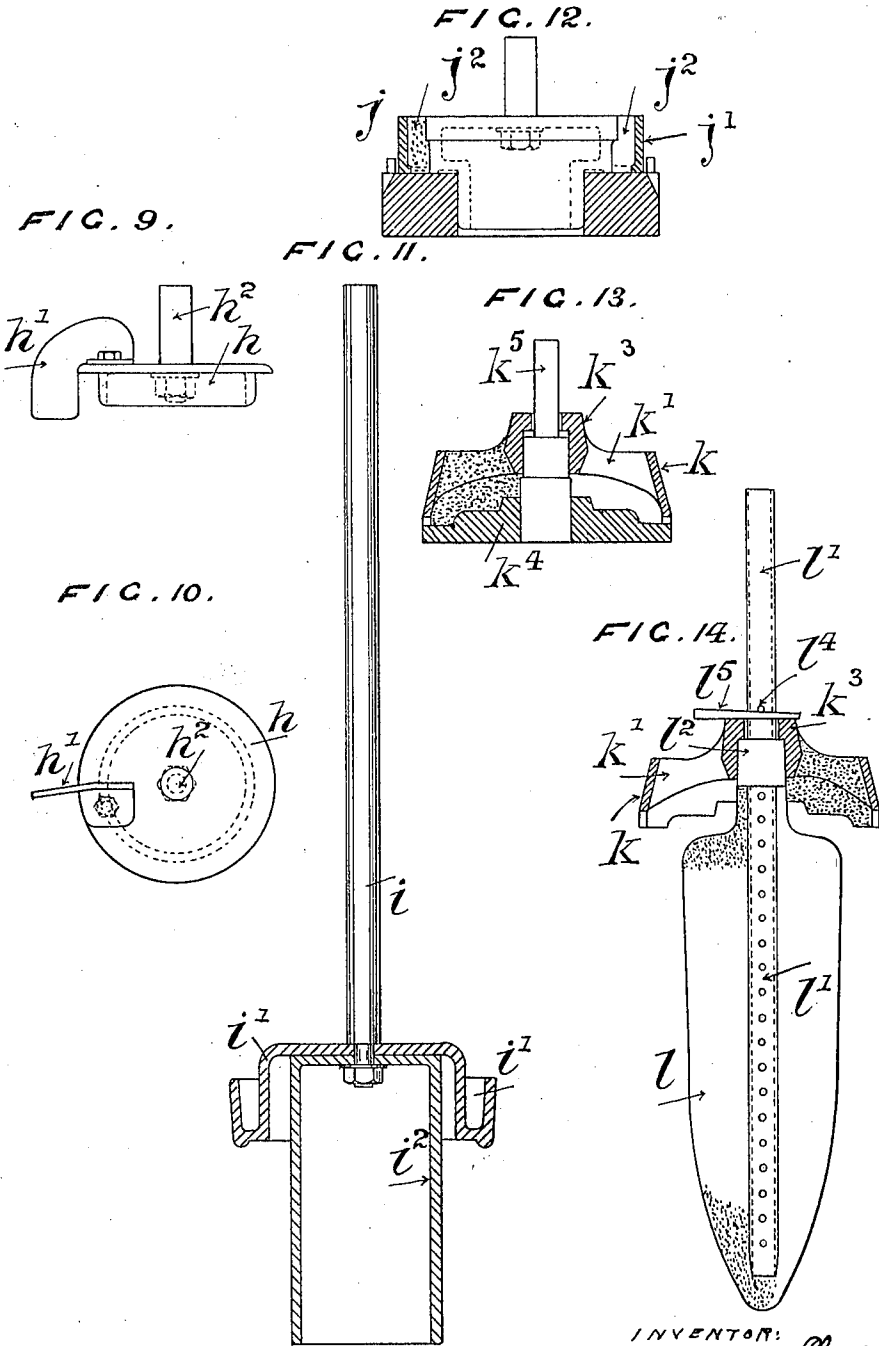

INVENTOR:  
*James Norman Chadwick*  
 By *Wm Wallace White*  
 ATT'Y.

# UNITED STATES PATENT OFFICE.

JAMES NORMAN CHADWICK, OF BOLTON, ENGLAND.

APPARATUS FOR CASTING BOMBS OR PROJECTILES.

1,298,176.

Specification of Letters Patent.

Patented Mar. 25, 1919.

Application filed June 5, 1918. Serial No. 238,271.

*To all whom it may concern:*

Be it known that I, JAMES NORMAN CHADWICK, a subject of the King of Great Britain and Ireland, residing at School Hill Iron-works, Bolton, in the county of Lancaster, England, have invented new and useful Improvements in Apparatus for Casting Bombs or Projectiles, of which the following is a specification.

This invention relates to improvements connected with the casting of bombs or projectiles, and, in particular, to the casting of what are known as 6" trench howitzer or Newton bombs, that is projectiles fitted with vanes at the conical extremity and which vanes have wires passed through or connected strips so as to form pockets for carrying propelling charges and also to support a detonator.

Prior to this time such bombs have been cast in permanent metal molds, which are expensive, while the bombs produced are hard to machine and have too many joint projections or ridges which lead away from accuracy. A further objection is, that the production can only take place while melting, thus limiting the molder's work to a period of the day.

I propose to make such bombs by repetition sand molding whereby the halves or parts of the molds can be rammed-up, assembled, provided with cores and generally completed in considerable numbers during the day and the metal run in the available batch of molds when melting.

The attached four sheets of drawings very fully illustrate the method followed and the means employed in producing complete sand rammed molds for casting said trench howitzer bombs in accordance with this invention.

In the said drawings.

Figure 1 is a section of the molding plate carrying the conical half pattern disposed in a trough together with the half molding box placed thereon and with the vane contrivance centered and in place, the half mold being ready for ramming.

Fig. 2 shows a plan of the molding plate carrying the half pattern seen in Fig. 1.

Fig. 3 is a detail elevation of the vane contrivance which is fixed to the bomb in the casting process.

Fig. 4 shows a plan of Fig. 3.

Fig. 5 shows a section of the half mold-

ing box seen in Fig. 1, the box having been rammed-up and inverted, the sand however not being fully shown.

Fig. 6 is a view of the 6" trench howitzer bomb as cast according to my invention. 60

Fig. 7 shows in section, the molding plate for the body portion of the bomb, together with an applied ring core and also the other half molding box.

Fig. 8 is a plan of the molding plate seen in Fig. 7. 65

Figs. 9 and 10 show in elevation and plan, the removable cover and rotatable strickle for the body pattern.

Fig. 11 shows in detail the movable rammer for making the print before applying the ring core. 70

Fig. 12 indicates the plant for producing the ring core.

Fig. 13 shows the plant for making the core for the top or fuse end of the bomb. 75

Fig. 14 illustrates the same core carrying the main internal or body core on an applied core venting tube.

Under my invention I make use of a permanent pattern plate *b* arranged upon a wooden or other stand *b'* which is placed in a shallow flagged trench *b<sup>2</sup>* on the foundry floor. This plate *b* carries a permanent half pattern *c* representing the conical end or half *a'* of the bomb or projectile *a* illustrated by Fig. 6. The permanent half pattern *c* has an annular projection *c'* to produce one of the bands or rings *a<sup>2</sup>* on the bomb or projectile body, and also slightly proud grooves or recesses *c<sup>2</sup>* at the conical end to receive the four fretted steel vanes *d* which are additionally bound together by the riveted ties or wires *d'* (see Figs. 3 and 4). This group of fretted vanes *d* I attach as a complete combination by fixing same in position by casting. The permanent pattern or molding plate *b* has a curved skimmer ledge *b<sup>3</sup>* and is designed to have a half molding box *e* fixed thereto, as for example said plate may have a hole *b<sup>4</sup>* and slot *b<sup>5</sup>* in which pins *b<sup>6</sup>* on the half molding box *e* socket. The half molding box *e* has a cross-bar *e'* (see Fig. 5) with a sawed centering boss *e<sup>2</sup>* to engage the upper crossing extremities of the group of vanes *d*. This group of fretted vanes *d* I apply by placing same in position on the conical extremity of the permanent half pattern *c* so that the four inner curved and fretted portions fit in the 110

grooves or recesses  $c^2$ , as will be understood. This done, the half molding box  $e$  is placed in position upon the plate  $b$ , the centering boss insuring the exact position of the applied vanes  $d$  with respect to the conical permanent half pattern  $c$ . The half molding box  $e$  is next filled and rammed with sand in the ordinary fashion. When the filling and ramming operation is completed, the half molding box  $e$  and the rest of the described plant is turned over, or inverted, which can be easily done in the trench, the lifting handles  $e^3$  facilitating this, as, when the box  $e$  is tilted, they will contact with the top of the trench and serve as fulcrum in the turning over movement. When the half molding box  $e$  has been properly inverted, the molding plate  $b$ , &c., is removed, and the completed half molding box  $e$  can be lifted away and placed on the foundry floor in the rammed-up condition represented by Fig. 5. I might arrange to lower the permanent half pattern  $c$  after the box  $e$  has been filled and rammed in lieu of turning over the box  $e$ .

Respecting the production of the other half molding box  $g$  for the body portion of the bomb or projectile I employ a permanent pattern plate  $f$  which has a cylindrical extension or sleeve  $f'$  properly turned and bored. The permanent pattern plate  $f$  is carried on a support  $f''$  placed on the foundry floor. Conveniently the cylindrical extension or sleeve  $f'$  is made slidable, the same sliding through the permanent pattern plate  $f$  and being moved up and down at the required times by a mechanical device, hydraulic pressure, or otherwise. If desired the plate  $f$  may be made to slide over the sleeve  $f'$ , in which case, when the pattern plate  $f$  is brought down in position it would rest on a ring surrounding and connected to the sleeve  $f'$ .

A removable cover  $h$  is applied to such cylindrical extension or sleeve  $f'$  the same being fully illustrated in Figs. 9 and 10, and same carries a strickle  $h'$  the cover having a handle  $h^2$  by which the device can be rotated when in position. The permanent pattern plate  $f$  has a curved skimmer ledge  $f^2$ , a hole  $f^3$  for the down runner bar  $f^4$ , and holes  $f^5$   $f^6$  or other provision to receive the pins on the half molding box  $g$  which is placed in position on the permanent pattern plate  $f$  and secured by engagement of the pins in the holes  $f^5$   $f^6$  as will be understood. After the removable cover  $h$  has been placed in position, and also the down runner bar  $f^4$ , the mold is filled and rammed with sand until the sand reaches nearly to the level of the top of the cylindrical extension or sleeve  $f'$ , whereupon the said cover  $h$  is rotated causing the strickle  $h'$  to clear the sand away from the immediate vicinity of the top of said cylindrical extension or sleeve  $f'$ . This done, said cover  $h$  is re-

moved, and, the rammer  $i$  with ring core positioning device  $i'$  is applied and worked up and down, the barrel  $i^2$  of the rammer  $i$  being guided by the bored portion of the cylindrical extension or sleeve  $f'$ . Such rammer  $i$  prepares a perfect and uniform and properly positioned seat in the sand for the ring core. Such ring core  $j$ , is conveniently prepared in the plant shown by Fig. 12, and it consists of a carrying ring of metal  $j'$  with a band like filling of sand  $j^2$ . This ring core  $j$ , produced in the plant such as indicated by Fig. 12, is, after proper drying, placed in position on the cylindrical extension or sleeve  $f'$ , exactly as shown in Fig. 7 and rests upon the sand seat, accurately prepared and positioned by the rammer  $i$ . The lower portion of the ring core  $j$  nicely fits the cylindrical extension or sleeve  $f'$ , as illustrated, and prevents sand from working up, while the upper portion of the sand stands just clear, thus leaving a slight annular space as Fig. 7 very clearly shows. The object of the ring core  $j$  is to provide for the band or ring  $a^3$  toward the fuse or butt end of the bomb or projectile (see Fig. 6).

The shape of the fuse end or base of the bomb or projectile is determined by a core formed within a dished metal plate  $k$  having webs  $k'$  which form interconnecting means between the metal plate  $k$  and an accurately bored boss  $k^2$ . This top ring core device is rammed with sand on a pattern plate  $k^4$  with centering device  $k^5$  shown in Fig. 13. I make the webs of such shape in cross section as to firmly retain the sand. This top ring core device, produced on the pattern plate  $k^4$ , is dried in the stove and is then ready to receive the internal or body core  $l$ . This body core  $l$  is separately prepared in a core producing plant and is supported on a venting core tube  $l'$  having an accurately shaped shoulder or enlargement  $l^2$  which fits the bored boss  $k^2$ . The internal or body core  $l$  on the venting core tube  $l'$  is fixed to and made one with the sand filled top ring core device  $k$  for forming the top of the bomb or projectile, by passing a fork  $l^5$  with wedge shaped prongs below the pin  $l^4$ . I thus get the bomb or projectile top ring core device  $k$  and the internal or body core  $l$  properly and accurately combined and as a complete thing as shown in Fig. 14. This complete core device as shown by Fig. 14, is then applied to the half, rammed-up molding box  $g$  by carefully lowering the internal or body core into the cylindrical extension or sleeve  $f'$  and until the lower edge of the metal ring  $k$  seats itself evenly and accurately on the upper edge of the metal ring  $j'$  of the ring core  $j$ .

When this has been done, the complete core device (Fig. 14) is in proper position. The further filling and ramming of the half molding box  $g$  with sand is now proceeded

with, and, when this has been done, the cores are found to be centrally and immovably held by the surrounding sand and are not liable to shift or move when the cylindrical extension or sleeve  $f'$  is drawn away. With the filling and ramming done, the preparation of the second half of molding box  $g$  is practically completed and such box  $g$  determines the exact shape of the body and fuse end portion of the bomb or projectile.

I prefer to withdraw downward the cylindrical extension or sleeve  $f'$ , by hydraulic or other means, and, on completion of the filling and ramming I effect withdrawal of the cylindrical extension or sleeve  $f'$  until same is sufficiently clear of the nose portion of the internal or body core  $l$ . This done, I withdraw the down runner  $f^4$  and lift the entire half molding box  $g$  clear of the pattern plate  $f$  by a straight lift and same is placed upon the half molding box  $e$ , Fig. 5, suitable provision being made for proper disposition or holding of one half box to the other as by the engagement of pins with holes.

I may arrange to simply lift the completed and rammed-up box  $g$  away from the permanent plate  $f$  and the cylindrical extension or sleeve  $f'$ .

When the two half boxes  $e$  and  $g$  are properly combined, a complete sand mold results with cores in perfect position, and it only remains to form a mouth to the down runner channel, which channel leads to the circular skimmer gates produced by the skimmer ledges  $b^3$ ,  $f^2$ , which, when casting takes place, deliver the metal about midway in the length of the bomb or projectile.

After casting and cooling have taken place, the molds are broken up, and the casting rattled and finished in suitable fashion as required.

By my invention I can cheapen and expedite the production of projectiles such as indicated and produce the projecting bands or rings and an accurately shaped extremity or head and eliminate the appearance of surface joints or projecting ridges such as are produced in the permanent metal molds and which have to be ground away, and also I can produce castings which are less hard to

grind or work. The molds as described can be quickly broken-up, filled and re-assembled.

I declare that what I claim is:—

1. An apparatus for making molds for casting bombs or projectiles comprising a pair of casings, a pair of coacting cores in said casings, means for permitting separate packing of the casings, band molding means coacting with each of said cores, and base molding means coacting with one of said cores and with one of said band molding means.

2. An apparatus for making molds for casting bombs or projectiles comprising a core for forming the nose of a projectile, said core having grooves formed therein, blades seated in said grooves, means for centering said blades with relation to said core, a second core independent of the first core for forming the body of a projectile, and an internal core rotatably mounted in said cores.

3. An apparatus for making molds for casting bombs or projectiles comprising a permanent pattern plate, a conical half pattern adapted to receive and seat vanes, a removable molding box with a vane centering device, therein, said box acting in conjunction with the pattern plates and conical half pattern device, whereby the vanes can be accurately centered in casting position on the conical part of a projectile.

4. An apparatus for making molds for casting bombs or projectiles comprising a casing, a core in said casing formed with grooves, vanes in said casing and seated in said grooves, and a centering device for said vanes.

5. An apparatus for making molds for casting bombs or projectiles comprising a pair of casings, a core in one of said casings for molding the nose of a projectile, a sleeve removably mounted in the other casing for molding the body of a projectile, a ring core associated with said sleeve for molding the base of a projectile, and a core disposed in said sleeve and first-mentioned core and rotatably mounted in said ring.

In testimony whereof I have signed my name to this specification.

JAMES NORMAN CHADWICK.