

(19) World Intellectual Property Organization
International Bureau



(43) International Publication Date
19 January 2006 (19.01.2006)

PCT

(10) International Publication Number
WO 2006/005796 A1

- (51) International Patent Classification:
H02K 15/03 (2006.01) *H02K 21/24* (2006.01)
- (21) International Application Number:
PCT/FI2005/000323
- (22) International Filing Date: 8 July 2005 (08.07.2005)
- (25) Filing Language: Finnish
- (26) Publication Language: English
- (30) Priority Data:
20040964 9 July 2004 (09.07.2004) FI
- (71) Applicant (for all designated States except US): **KONE CORPORATION** [FI/FI]; Kartanontie 1, FI-00330 Helsinki (FI).
- (72) Inventors; and
- (75) Inventors/Applicants (for US only): **HULT, Arttu** [FI/FI]; Korppanmäentie 30 B 20, FI-00300 Helsinki (FI). **TENHUNEN, Asmo** [FI/FI]; Koivulankatu 1 B, FI-05830 Hyvinkää (FI). **ÖSTERMAN, Jari** [FI/FI]; Kaunismäentie 15, FI-11120 Riihimäki (FI).
- (74) Agent: **KONE CORPORATION / PATENT DEPARTMENT**; P.O. Box 677, FI-05801 Hyvinkää (FI).

- (81) Designated States (unless otherwise indicated, for every kind of national protection available): AE, AG, AL, AM, AT, AU, AZ, BA, BB, BG, BR, BW, BY, BZ, CA, CH, CN, CO, CR, CU, CZ, DE, DK, DM, DZ, EC, EE, EG, ES, FI, GB, GD, GE, GH, GM, HR, HU, ID, IL, IN, IS, JP, KE, KG, KM, KP, KR, KZ, LC, LK, LR, LS, LT, LU, LV, MA, MD, MG, MK, MN, MW, MX, MZ, NA, NG, NI, NO, NZ, OM, PG, PH, PL, PT, RO, RU, SC, SD, SE, SG, SK, SL, SM, SY, TJ, TM, TN, TR, TT, TZ, UA, UG, US, UZ, VC, VN, YU, ZA, ZM, ZW.
- (84) Designated States (unless otherwise indicated, for every kind of regional protection available): ARIPO (BW, GH, GM, KE, LS, MW, MZ, NA, SD, SL, SZ, TZ, UG, ZM, ZW), Eurasian (AM, AZ, BY, KG, KZ, MD, RU, TJ, TM), European (AT, BE, BG, CH, CY, CZ, DE, DK, EE, ES, FI, FR, GB, GR, HU, IE, IS, IT, LT, LU, LV, MC, NL, PL, PT, RO, SE, SI, SK, TR), OAPI (BF, BJ, CF, CG, CI, CM, GA, GN, GQ, GW, ML, MR, NE, SN, TD, TG).

Published:
— with international search report

For two-letter codes and other abbreviations, refer to the "Guidance Notes on Codes and Abbreviations" appearing at the beginning of each regular issue of the PCT Gazette.

(54) Title: METHOD AND APPARATUS FOR THE ASSEMBLY OF AN AXIAL-FLUX PERMANENT-MAGNET SYNCHRONOUS MACHINE

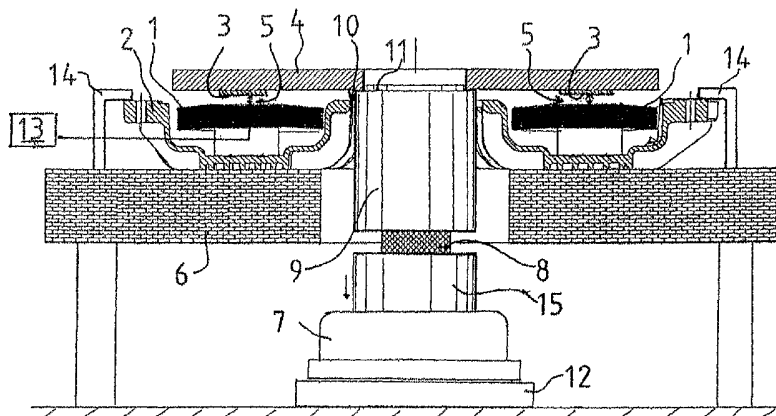

(57) Abstract: The invention relates to a method and an apparatus for use in the assembly of an axial-flux permanent-magnet synchronous machine. The machine comprises a stator (2) provided with windings (1) and a rotor (4) provided with permanent magnets. An air gap (5) being provided between the stator and rotor. A known interdependence of the magnetic attraction between the stator (2) and the rotor (4) and the magnitude of the air gap is determined beforehand. Based on this interdependence, a target value of magnetic attraction corresponding to the target value of the air gap is determined. When the machine is being assembled, the rotor (4) and stator (2) are moved axially with respect to each other by means of a hoisting device (7) to adjust the air gap (5) towards the aforesaid predetermined target value. During this movement, the magnetic attraction between the stator (2) and rotor (4) is measured and compared to the above-mentioned target value of magnetic attraction. After the magnetic attraction has reached its target value, which corresponds to the target value of the air gap, the mutual position of the rotor and stator is locked.

WO 2006/005796 A1

**METHOD AND APPARATUS FOR THE ASSEMBLY OF AN AXIAL-FLUX
PERMANENT-MAGNET SYNCHRONOUS MACHINE**

FIELD OF THE INVENTION

5 The present invention relates to a method as defined in the preamble of claim 1. Moreover, the invention relates to an apparatus as defined in the preamble of claim 8.

10 **BACKGROUND OF THE INVENTION**

Axial-flux permanent-magnet synchronous machines are used e.g. as elevator drive motors. Regarding their operation, the air gap between the stator and the rotor has a substantial influence on the performance of the machine. The length of the air gap in relation to the other dimensions of the machine is very small. In an embodiment, the mechanical air gap is about 1.2 mm. In addition, large magnetic forces between rotor and stator act in the air gap. In the above-mentioned embodiment, the magnetic force is about 9 kN. Magnetically the air gap is in reality different from the air gap that can be mechanically measured.

In the manufacture of axial-flux permanent-magnet synchronous machines, the adjustment of the air gap is accomplished by using gauges to measure the adjoining parts, and the need for shims used in the adjustment is determined on the basis of the results. Whether the adjustment was successful or not can only be established in the type testing performed on the machine when fully assembled. This testing includes measurement of the electromotive force of the machine, i.e. the voltage induced by the rotor into the stator winding when the rotor is rotated. If the air gap is not correct, the measurement produces a wrong electromotive force. To correct the air gap, the machine has to

be disassembled. The accuracy of the adjustment depends on the carefulness of the person carrying out the adjustment, which is why in type testing fairly large tolerances regarding the electromotive force are allowed. The assembly of the rotor and stator by current techniques is a relatively uncontrolled process due to the magnetic force between the rotor and stator. The rotor may be thrust against its supporting surface, impairing the safety of the assembly work and the reliability of the machine. One of the commonest reasons for rejection of a machine in type testing at present is an incorrect electromotive force of the motor, which is due to an incorrect air gap size.

With current technology, the assembly of the machine is implemented by utilizing auxiliary screws, and the air gap is adjusted manually by measuring the air gap. In an example case, by using mechanical feeler gauges or slide gauges, a measuring accuracy of about 0.1 mm is achieved, which corresponds in magnetic force to about 300 N. The operation requires a great deal of manual work and involves many uncertainty factors. In addition, the measurement of the air gap is actually an indirect measurement, because the thickness of the magnets, glue layers and protective aluminum has to be added to the magnetically interesting measured air gap value.

OBJECT OF THE INVENTION

The object of the present invention is to overcome the above-mentioned drawbacks.

A specific object of the invention is to disclose a new type of method that will enable more accurate adjustment of the air gap and thereby more accurate adjustment of the operating characteristics of the machine than before.

A further object of the invention is to disclose a method that will accelerate the assembly of the machine, reduce the number of machines rejected in type
5 testing due to an incorrect air gap and that will thus improve the quality of the machines and reduce the time required for quality control.

A further object of the invention is to disclose a
10 method that will improve work safety in assembly work.

BRIEF DESCRIPTION OF THE INVENTION

The method of the invention is characterized by what is disclosed in the characterization part of claim 1.
15 The apparatus of the invention is characterized by what is disclosed in the characterization part of claim 8. Other embodiments of the invention are characterized by what is disclosed in the other claims. Inventive embodiments are also presented in the de-
20 scription part and drawings of the present application. The inventive content disclosed in the application can also be defined in other ways than is done in the claims below. The inventive content may also consist of several separate inventions, especially if the inven-
25 tion is considered in the light of explicit or implicit sub-tasks or in respect of advantages or sets of advantages achieved. In this case, some of the attributes contained in the claims below may be superfluous from the point of view of separate inventive concepts.
30 Within the framework of the basic concept of the invention, features of different embodiments of the invention can be applied in conjunction with other em-
bodiments.

35 According to the invention, a known interdependence of the magnetic attraction between stator and rotor and the magnitude of the air gap is determined beforehand.

Based on this known interdependence, a target value of magnetic attraction corresponding to the target value of the desired air gap is determined. When the rotor and stator are being mounted during assembly, the rotor and stator are moved axially with respect to each other to adjust towards the predetermined target value. During this movement, the magnetic attraction between the stator and rotor is measured. The measured magnetic attraction is compared to the target value of magnetic attraction corresponding to the target value of the desired air gap. After the magnetic attraction has reached the target value corresponding to the target value of the desired air gap, the mutual position of the rotor and stator is locked.

Further according to the invention, the apparatus comprises means for moving the rotor and stator axially with respect to each other, and means for measuring the magnetic attraction between the rotor and stator.

The invention has the advantage that, during assembly of the machine, before the machine has been completely assembled, the adjustment of the air gap accomplished indirectly by utilizing the magnetic attraction allows more accurate adjustment of the air gap and consequently of the operating characteristics of the machine than before. The magnetic force can be easily measured with an accuracy of about 30 N, and thus when the air gap is adjusted in this manner, an adjusting accuracy about ten times higher is obtained than by prior-art methods.

A further advantage of the invention is that assembly of the machine is accelerated as it is no longer necessary to disassemble the machine for re-adjustment of the air gap after type testing. The quality of the machines is good, and the time required for quality con-

trol is short. Work safety in assembly work is improved because the rotor can not be thrust against the stator in an uncontrolled manner by magnetic attraction.

5

In an embodiment of the method, the air gap is adjusted by reducing the air gap from a value larger than the predetermined target value of the air gap towards the predetermined target value, and/or by increasing the air gap from a value smaller than the predetermined target value of the air gap towards the predetermined target value.

In an embodiment of the method, to adjust the air gap, the stator is immovably secured in place and the rotor is moved axially with respect to the stator.

In an embodiment of the method, after the air gap adjustment performed by utilizing the magnetic attraction, before the mutual position of the stator and rotor is locked, the rotor is rotated in relation to the stator at a predetermined low rotational speed. While the rotor is being rotated, the electromotive force induced in the stator winding is measured. This electromotive force is compared to a target electromotive force value corresponding to the target value of the air gap. The air gap is fine-adjusted if the measured electromotive force differs from the target electromotive force value. Via fine adjustment performed by directly measuring the electromotive force while the rotor is being rotated, it is possible to compensate deviations between the rotational and central axes of the rotor and stator and their angular positions.

In an embodiment of the method, assembly of the machine is only continued after adjustment of the air gap.

In an embodiment of the method, the stator is secured to a fixed base so that the axial direction of the stator is vertical. The rotor is connected to a hoisting device. By means of the hoisting device, the rotor is lowered axially towards the stator in such manner that the central axis of the rotor simultaneously coincides with the central axis of the stator. The magnetic attraction between the rotor and stator is measured by means of a force measuring device.

In an embodiment of the method, the hoisting device is arranged below the stator. As a force measuring device, a pressure scales placed on the hoisting device is used. A supporting element is placed upon the pressure scales, so that the pressure scales remains between the hoisting device and the rotor. The supporting element is pushed through the central hole of the stator so that the upper supporting surface of the supporting element extends above the stator to a distance from the stator exceeding the target value of the air gap. The rotor is placed on the upper supporting surface and left resting on it. Using the hoisting device, the rotor is lowered downwards and the magnetic attraction is measured by means of the pressure scales.

In an embodiment of the apparatus, the apparatus comprises a fastening element for securing the stator to a fixed base so that the axial direction of the stator is vertical.

In an embodiment of the apparatus, the apparatus comprises a supporting element having an upper supporting surface for supporting the rotor.

In an embodiment of the apparatus, the means for moving the rotor and stator axially with respect to each other comprise a hoisting device.

- 5 In an embodiment of the apparatus, the hoisting device comprises a plunger movable in the vertical direction, such as a piston or the like.

10 In an embodiment of the apparatus, the means for measuring the magnetic attraction between the rotor and stator comprise a pressure scales arranged between the plunger and the supporting element.

LIST OF FIGURES

- 15 In the following, the invention will be described in detail with reference to embodiment examples and the attached drawing, wherein

20 Fig. 1 presents a longitudinal sectional view of an embodiment of the apparatus of the invention, and Fig. 2 illustrates the interdependence between the air gap and the magnetic attraction in an axial-flux permanent-magnet synchronous machine.

25 DETAILED DESCRIPTION OF THE INVENTION

Fig. 1 shows an apparatus for the assembly of a axial-flux permanent-magnet synchronous machine and adjustment of the air gap.

30 The axial-flux permanent-magnet synchronous machine has a stator 2 provided with windings 1 and a rotor 4 provided with permanent magnets 3. Between the stator 2 and the rotor 4 is an air gap 5. The stator 2 and the rotor 4 are disposed one after the other in the
35 direction of the rotational axis of the rotor. The air gap 5 is preferably in a plane at right angles to the

rotational axis of the rotor 4. Fig. 1 does not show the bearings between the rotor and stator.

The apparatus comprises a work table provided with a hole and forming a fixed base 6, to which the stator 2 can be secured with fastening elements 14, preferably snap-on fasteners, so that the central axis of the stator 2 is vertical.

10 The apparatus comprises a hoisting device 7, by means of which the rotor 2 can be moved axially in the vertical direction relative to the stator 3. The hoisting device 7 comprises a vertically movable plunger 15. The hoisting device 7 may be e.g. a hydraulic jack; in
15 which case the plunger 15 is the piston of the jack. Further, the apparatus comprises a pressure scales 8, which is arranged on the plunger 15 to measure the magnetic attraction between the rotor 4 and the stator 2. Placed upon the pressure scales 8 is supporting
20 element 9, which has an upper supporting surface 11 for supporting the rotor 4. Thus, the magnetic force can act via the supporting element 9 on the pressure scales 8, by means of which the magnetic attraction can be measured. In addition, the apparatus comprises
25 a rotator device 12 for rotating the rotor 4, and measuring means 13 for measuring the electromotive force induced in the winding 1 of the stator 2.

Fig. 2 illustrates the relationship of the magnetic
30 force between the stator 2 and the rotor 4 to the magnitude of the air gap as calculated in an example case. The magnetic force is the greater the smaller is the air gap. The interdependence is nearly linear. It is not exactly linear, but it can be linearized, in
35 which case the linearization applies to a limited air gap length. The interdependence can be determined beforehand via calculation or it can be measured.

The known interdependence of the magnetic attraction between the stator 2 and rotor 4 and the magnitude of the air gap 5 is determined beforehand via calculation. Based on this known interdependence, a target value of the magnetic attraction corresponding to a target value of the desired air gap is determined.

To mount the rotor 4 and stator 2 with respect to each other during assembly, the following procedure is observed.

First, the stator 2 is immovably secured in place on the work table by means of fastening elements 14 in the position shown in Fig. 1, where the axial direction of the stator is vertical. The hoisting device 7 is arranged below the stator 2. The pressure scales 8 is placed on the hoisting device 7. The supporting element 9 is placed on the pressure scales 8. The supporting element 9 is pushed through the central opening 10 of the stator 2 so that the upper supporting surface 11 of the supporting element extends to a distance from and above the stator larger than the target value of the air gap 5. The rotor 4 is placed upon the upper supporting surface 11 of the supporting element 9 and left resting on it.

The target value of the air gap can be adjusted by decreasing and/or increasing the air gap. If the starting value of the air gap in the initial situation is larger than the target value, then the rotor 4 is lowered slowly by means of the hoisting device 7, starting from the aforesaid target value of the air gap, which is larger than the desired target value, towards the target value corresponding to the operating characteristics specified for the machine. In a corresponding manner, the air gap can be adjusted by in-

creasing the air gap. During the movement, the magnetic attraction between the stator 2 and rotor 4 *is measured* by means of the pressure scales 8. The measured magnetic attraction *is compared* to the target value of the magnetic attraction corresponding to the target value of the desired air gap. When the magnetic attraction reaches the target value, which corresponds to the target value of the desired air gap, the mutual position of the rotor 2 and stator 4 is locked.

10

After the air gap adjustment performed by utilizing the magnetic attraction and before the mutual position of the rotor 2 and stator 4 is locked, the air gap can be further fine-adjusted as follows.

15

The rotor 4 is rotated by means of the rotator device 12 in relation to the stator 2 at a predetermined low rotational speed. At the same time, the electromotive force induced in winding 1 of the stator 2 is measured from the stator terminals. The measured electromotive force is compared to a target value of the electromotive force corresponding to the target value of the air gap. If the measured electromotive force differs from the target value of the electromotive force, then the air gap is adjusted further.

25

Once the air gap 5 has been adjusted in the manner described above, the assembly of the machine can be continued.

30

The invention is not limited to the embodiment examples described above; instead, many variations are possible within the scope of the inventive concept defined in the claims.

35

LIST OF REFERENCE NUMBERS:

	windings	(1)
	stator	(2)
5	permanent magnets	(3)
	rotor	(4)
	air gap	(5)
	fixed base	(6)
	hoisting device	(7)
10	force measuring device	(8)
	supporting element	(9)
	center hole	(10)
	upper supporting surface	(11)
	rotator means	(12)
15	measuring means	(13)
	fastening element	(14)
	plunger	(15)
20		
25		
30		
35		
40		
45		
50		

CLAIMS

1. A method for the assembly of an axial-flux permanent-magnet synchronous machine, said machine comprising a stator (2) provided with windings (1) and a rotor (4) provided with permanent magnets, an air gap (5) being provided between said stator and rotor, in which machine the stator (2) and the rotor (4) are arranged in succession in the direction of the rotational axis of the rotor, and in which method the air gap is adjusted, characterized in that

- a known interdependence of the magnetic attraction between the stator (2) and the rotor (4) and the magnitude of the air gap is determined beforehand, and

- based on said known interdependence, a target value of magnetic attraction corresponding to the target value of the desired air gap is determined,

20

and when the rotor (4) and stator (2) are being mounted in relation to each other:

- the rotor (4) and stator (2) are moved axially with respect to each other to adjust the air gap (5) towards the aforesaid predetermined target value,

25

- during this movement, the magnetic attraction between the stator (2) and rotor (4) is measured,

30

- the measured magnetic attraction is compared to the target value of magnetic attraction corresponding to the target value of the desired air gap,

- after the magnetic attraction has reached the target value corresponding to the target value of the desired

35

air gap, the mutual position of the rotor and stator is locked.

2. A method according to claim 1, characterized in that the air gap (5) is adjusted by reducing the air gap from a value larger than the predetermined target value of the air gap towards the predetermined target value, and/or by increasing the air gap from a value smaller than the predetermined target value of the air gap towards the predetermined target value.

3. A method according to claim 1 or 2, characterized in that, to adjust the air gap (5), the stator (2) is immovably secured in place and the rotor (4) is moved axially with respect to the stator.

4. A method according to claim 3, characterized in that, after the air gap adjustment performed by utilizing magnetic attraction, before the mutual position of the stator (2) and rotor (4) is locked:

- the rotor (4) is rotated in relation to the stator (2) at a predetermined low rotational speed,
- 25 - while the rotor (4) is being rotated, the electromotive force induced in the winding (1) of the stator (2) is measured,
- the measured electromotive force is compared to a target electromotive force value corresponding to the target value of the air gap, and
- 30 - the air gap (5) is fine-adjusted if the measured electromotive force differs from the target electromotive force value.
- 35

5. A method according to any one of claims 1 - 4, characterized in that the assembly of the machine is only continued after the adjustment of the air gap (5).

5

6. A method according to any one of claims 1 - 4, characterized in that

10 - the stator (2) is secured to a fixed base (6) so that the axial direction of the stator is vertical.

- the rotor (4) is connected to a hoisting device (7),

15 - the rotor (4) is lowered axially towards the stator (2) by means of the hoisting device (7) in such manner that the central axis of the rotor simultaneously coincides with the central axis of the stator, and

20 - magnetic attraction between the rotor and stator is measured by means of a force measuring device (8).

7. A method according to claim 6, characterized in that

25 - the hoisting device (7) is arranged below the stator (2),

30 - as a force measuring device (8) is selected a pressure scales (8), which is placed on the hoisting device (7),

- a supporting element (9) is placed upon the pressure scales (8), so that the pressure scales remains between the hoisting device (7) and the rotor (4),

35

- the supporting element (9) is pushed through the center hole (10) of the stator (2) so that the upper

supporting surface (11) of the supporting element extends above the stator to a distance from the stator exceeding the target value of the air gap (5),

5 - the rotor (4) is placed on the upper supporting surface (11) and left resting on it, and

- using the hoisting device (7), the rotor (4) is lowered downwards and the magnetic attraction is measured
10 by means of the pressure scales (8).

8. An apparatus for the assembly of an axial-flux permanent-magnet synchronous machine, said machine comprising a stator (2) provided with windings (1) and a
15 rotor (4) provided with permanent magnets, an air gap (5) being provided between said stator and rotor, in which machine the stator (2) and the rotor (4) are arranged in succession in the direction of the rotational axis of the rotor, said apparatus being in-
20 tended for adjustment of the air gap, characterized in that the apparatus comprises means (7) for moving the rotor (4) and stator (2) axially with respect to each other, and means (8) for measuring the magnetic attraction between the rotor and stator.

25

9. An apparatus according to claim 8, characterized in that the apparatus comprises rotator means (12) for rotating the rotor (4) and measuring means (13) for measuring the electromotive force induced in
30 the winding (1) of the stator (2).

10. An apparatus according to claim 8 or 9, characterized in that the apparatus comprises a fastening element (14) for securing the stator (2) to a
35 fixed base (6) so that the axial direction of the stator is vertical.

11. An apparatus according to any one of claims 8 - 10, characterized in that the apparatus comprises a supporting element (9) having an upper supporting surface (11) for supporting the rotor (4).

5

12. An apparatus according to any one of claims 8 - 11, characterized in that the means for moving the rotor (2) and stator (3) axially with respect to each other comprise a hoisting device (7).

10

13. An apparatus according to claim 12, characterized in that the hoisting device (7) comprises a plunger (15) movable in the vertical direction, such as a piston or the like.

15

14. An apparatus according to claim 13, characterized in that the means for measuring the magnetic attraction between the rotor (4) and stator (2) comprise a pressure scales (8), which is arranged between the plunger (15) and the supporting element (9).

20

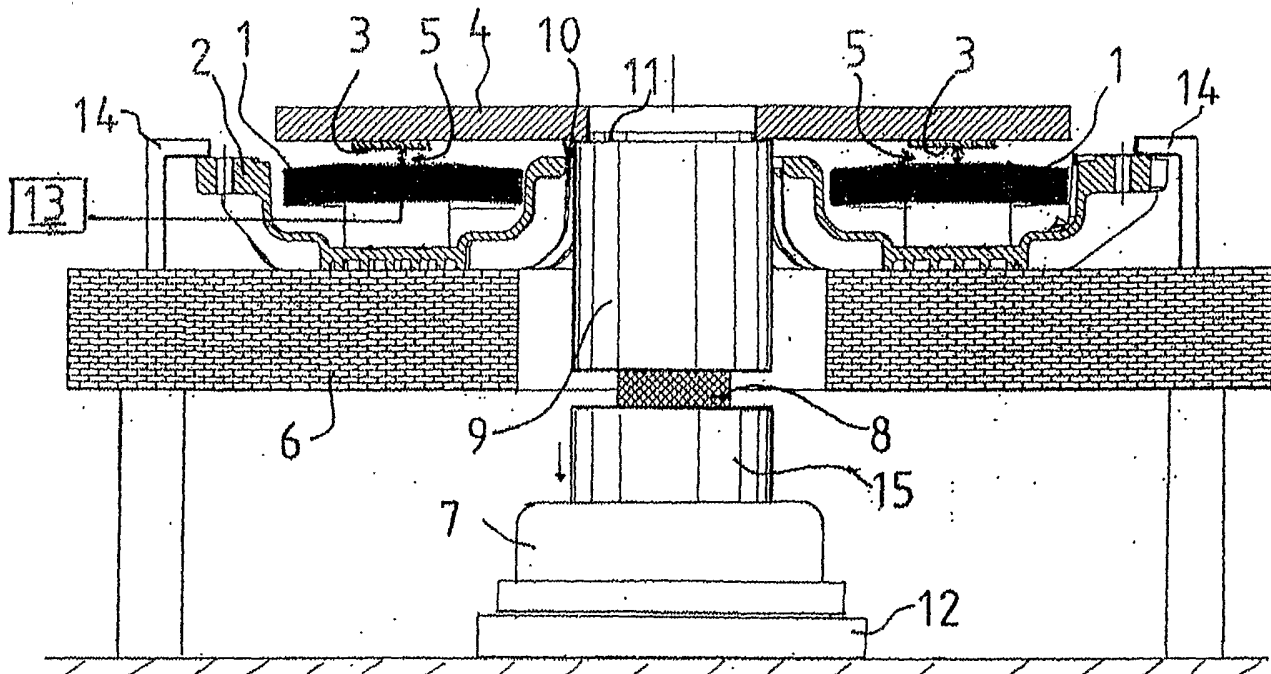

Fig 1

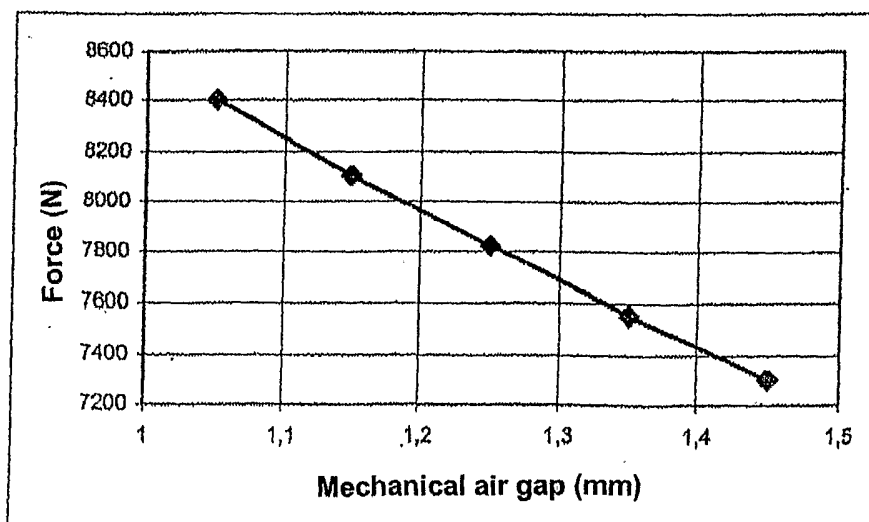

Fig 2

INTERNATIONAL SEARCH REPORT

International application No.

PCT/FI2005/000323

A. CLASSIFICATION OF SUBJECT MATTER IPC8: H02K15/03, H02K21/24 According to International Patent Classification (IPC) or to both national classification and IPC		
B. FIELDS SEARCHED Minimum documentation searched (classification system followed by classification symbols) IPC8: H02K Documentation searched other than minimum documentation to the extent that such documents are included in the fields searched FI, SE, NO, DK, classes as above Electronic data base consulted during the international search (name of data base and, where practicable, search terms used) EPO-Internal, WPI, PAJ, INSPEC, IEEE-Xplore		
C. DOCUMENTS CONSIDERED TO BE RELEVANT		
Category*	Citation of document, with indication, where appropriate, of the relevant passages	Relevant to claim No.
A	US 2861238 A (WILLIAM KOBER) 18 November 1958 (18.11.1958), (See: abstract, column 5, rows 30-32, claims and figures)	1-7
A	SU 521635 A (KUZNETSOV N F) 15 July 1976 (15.07.1976), World Patent Index [online]. London, U.K.: Derwent Publications, Ltd. [retrieved on 2005-21-09]. Retrieved from: EPOQUE WPI Database. Accession No. 1977-D8995Y, Derwent Week 197719, (See: abstract and figures)	1-7
A	JP 58029349 A (TOKYO SHIBAURA ELECTRIC CO) 21 February 1983 (21.02.1983), Patent Abstracts of Japan, (See: abstract and figures)	1-7
A	JP 8298755 A (NIKKISO CO LTD) 12 November 1996 (12.11.1996), Patent Abstracts of Japan, (See: abstract and figures)	8-14
A	SU 1833942 A1 (USACHEV ANATOLIJ I) 15 August 1993 (15.08.1993), World Patent Index [online]. London, U.K.: Derwent Publications, Ltd. [retrieved on 2005-21-09]. Retrieved from: EPOQUE WPI Database. Accession No. 1995-073462, Derwent Week 199510, (See: abstract and figures)	8-14
<input checked="" type="checkbox"/> Further documents are listed in the continuation of Box C. <input checked="" type="checkbox"/> See patent family annex.		
<p>* Special categories of cited documents:</p> <p>"A" document defining the general state of the art which is not considered to be of particular relevance</p> <p>"E" earlier application or patent but published on or after the international filing date</p> <p>"L" document which may throw doubts on priority claim(s) or which is cited to establish the publication date of another citation or other special reason (as specified)</p> <p>"O" document referring to an oral disclosure, use, exhibition or other means</p> <p>"P" document published prior to the international filing date but later than the priority date claimed</p> <p>"T" later document published after the international filing date or priority date and not in conflict with the application but cited to understand the principle or theory underlying the invention</p> <p>"X" document of particular relevance; the claimed invention cannot be considered novel or cannot be considered to involve an inventive step when the document is taken alone</p> <p>"Y" document of particular relevance; the claimed invention cannot be considered to involve an inventive step when the document is combined with one or more other such documents, such combination being obvious to a person skilled in the art</p> <p>"&" document member of the same patent family</p>		
Date of the actual completion of the international search 27 September 2005 (27.09.2005)		Date of mailing of the international search report 03 October 2005 (03.10.2005)
Name and mailing address of the ISA/FI Patentti- ja rekisterihallitus PL 1160, 00101 Helsinki Facsimile No. +358 9 6939 5328		Authorized officer Marko Lammintausta Telephone No. +358 9 6939 500

INTERNATIONAL SEARCH REPORT

International application No.

PCT/FI2005/000323

C (Continuation). DOCUMENTS CONSIDERED TO BE RELEVANT		
Category*	Citation of document, with indication, where appropriate, of the relevant passages	Relevant to claim No.
A	JP 3284143 A (TOKYO SHIBAURA ELECTRIC CO) 13 December 1991 (13.12.1991), Patent Abstracts of Japan, (See: abstract and figures)	8-14
A	GB 2289947 A (BOHLIN INSTR UK LTD et al.) 06 December 1995 (06.12.1995), (See: abstract and figures)	1-14
A	GB 651875 A (BOLIDENS GRUV AB) 11 April 1951 (11.04.1951), (See: abstract and figures)	1-14

INTERNATIONAL SEARCH REPORT
Information on patent family members

International application No.
PCT/FI2005/000323

Patent document cited in search report	Publication date	Patent family members(s)	Publication date
US 2861238 A	18/11/1958	US 2784332 A	05/03/1957
.....			
SU 521635 A	15/07/1976	None	
.....			
JP 58029349 A	21/02/1983	None	
.....			
JP 8298755 A	12/11/1996	None	
.....			
SU 1833942 A1	15/08/1993	None	
.....			
JP 3284143 A	13/12/1991	None	
.....			
GB 2289947 A	06/12/1995	None	
.....			
GB 651875 A	11/04/1951	None	
.....			