

(19) World Intellectual Property
Organization
International Bureau



(43) International Publication Date
2 June 2005 (02.06.2005)

PCT

(10) International Publication Number
WO 2005/050148 A2

- (51) International Patent Classification⁷: **G01J**
- (21) International Application Number:
PCT/US2004/037517
- (22) International Filing Date:
9 November 2004 (09.11.2004)
- (25) Filing Language: English
- (26) Publication Language: English
- (30) Priority Data:
60/520,944 18 November 2003 (18.11.2003) US
- (71) Applicant (for all designated States except US): **OC-TADEM TECHNOLOGIES** [—/US]; 14 Kehoe Court, Princeton Junction, NJ 08550 (US).
- (72) Inventors; and
- (75) Inventors/Applicants (for US only): **HE, Fan** [US/US]; 133 Mainsail Drive, Grayslake, IL 60030 (US). **ZHIHAO, Lin** [US/US]; 14 Kehoe Court, Princeton Junction, NJ 08550 (US). **YUE, Yao** [US/US]; 18216 61 Ave. NE., Kenmore WA 98028 (US).
- (74) Common Representative: **ZHIHAO, Lin**; 14 Kehoe Court, Princeton Junction, NJ 08550 (US).
- (81) Designated States (unless otherwise indicated, for every kind of national protection available): AE, AG, AL, AM, AT, AU, AZ, BA, BB, BG, BR, BW, BY, BZ, CA, CH, CN, CO, CR, CU, CZ, DE, DK, DM, DZ, EC, EE, EG, ES, FI, GB, GD, GE, GH, GM, HR, HU, ID, IL, IN, IS, JP, KE, KG, KP, KR, KZ, LC, LK, LR, LS, LT, LU, LV, MA, MD, MG, MK, MN, MW, MX, MZ, NA, NI, NO, NZ, OM, PG, PH, PL, PT, RO, RU, SC, SD, SE, SG, SK, SL, SY, TJ, TM, TN, TR, TT, TZ, UA, UG, US, UZ, VC, VN, YU, ZA, ZM, ZW.
- (84) Designated States (unless otherwise indicated, for every kind of regional protection available): ARIPO (BW, GH, GM, KE, LS, MW, MZ, NA, SD, SL, SZ, TZ, UG, ZM, ZW), Eurasian (AM, AZ, BY, KG, KZ, MD, RU, TJ, TM), European (AT, BE, BG, CH, CY, CZ, DE, DK, EE, ES, FI, FR, GB, GR, HU, IE, IS, IT, LU, MC, NL, PL, PT, RO, SE, SI, SK, TR), OAPI (BF, BJ, CF, CG, CI, CM, GA, GN, GQ, GW, ML, MR, NE, SN, TD, TG).
- Published:**
— without international search report and to be republished upon receipt of that report
- For two-letter codes and other abbreviations, refer to the "Guidance Notes on Codes and Abbreviations" appearing at the beginning of each regular issue of the PCT Gazette.

(54) Title: COMPACT SPECTRAL READERS FOR ACCURATE COLOR DETERMINATION

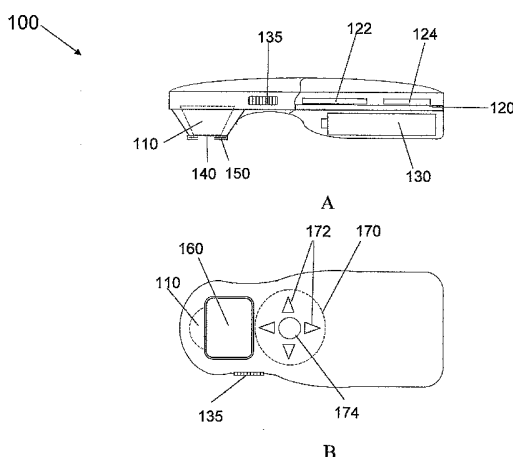

(57) Abstract: Systems and methods for providing spectral measurements are described. In one embodiment, a spectral measuring device comprises at least one radiation source configured to provide N ($N \geq 2$) linearly independent illuminant sources characterized by M ($M \geq N$) wavelength channels in a predetermined wavelength range; a sensor unit including at least one sensor, configured to be in optical communication with the radiation sources and an object; a memory storing an illuminant characterization matrix including spectral characteristics of the N illuminant sources in the M wavelength channels; and a processor configured to provide spectral responses of the object in the M wavelength channels, based at least in part on the illuminant characterization matrix. The embodiments of the invention can be used to construct a new class of compact spectral measuring devices, such as handheld color measuring devices.

WO 2005/050148 A2

COMPACT SPECTRAL READERS FOR ACCURATE COLOR DETERMINATION

CROSS REFERENCE TO RELATED APPLICATIONS

[0001] This application claims priority to U.S. Provisional Patent Application Number 60/520,944, filed on November 18, 2003, the entirety of which is hereby incorporated by reference.

FIELD OF THE INVENTION

[0002] This invention generally relates to spectral measuring systems. More specifically, embodiments of the invention can be used to construct a new class of compact spectral measuring devices, such as handheld color measuring devices.

BACKGROUND

[0003] Spectral (or color) measurement is required in many industries or businesses that produce, use, or sell dyes, inks, paints, and other color products. Color measurement has also become increasingly involved in consumer products. For example, many test products used in laboratories or households for conducting chemical or biochemical analyses display the test results by way of color, as evaluated by eyes or by color measuring devices. In many applications, it is desirable to have spectral (or color) measuring devices that are compact in size (e.g., handheld), accurate in color determination, and economical in cost.

[0004] Conventional spectral measuring devices employ diffraction gratings and associated optical elements to detect the spectral responses (or colors) of a test object. As a result, such devices are characteristically expensive and bulky, rendering them unsuitable as consumer products. Although relatively inexpensive and lightweight devices for color measurement have become available in recent years, which make use of light emitting diodes (LEDs) for illumination and optical sensors for detection, these devices suffer a number of limitations, notably unsatisfactory accuracy in color determination.

[0005] In view of the forgoing, a need therefore exists in the art, for spectral measuring devices that overcome the aforementioned limitations.

SUMMARY

[0006] Embodiments of the invention relate to spectral measuring systems.

[0007] In one embodiment, a spectral measuring device comprises at least one radiation source configured to provide N ($N \geq 2$) linearly independent illuminant sources characterized by M ($M \geq 2$) wavelength channels in a predetermined wavelength range; a sensor unit including at least one sensor, configured to be in optical communication with the radiation sources and an object; a memory storing an illuminant characterization matrix including spectral characteristics of the N illuminant sources in the M wavelength channels; and a processor configured to provide spectral responses of the object in the M wavelength channels, based at least in part on the illuminant characterization matrix.

[0008] The above and other embodiments are mentioned not to limit or define the invention, but to provide examples of embodiments of the invention to aid understanding thereof. Embodiments are discussed in the Detailed Description, and further description of the invention is provided there. Advantages offered by the various embodiments of the invention may be further understood by examining this specification.

BRIEF DESCRIPTION OF THE FIGURES

[0009] These and other features, aspects, and advantages of the present invention are better understood when the following Detailed Description is read with reference to the accompanying drawings, wherein:

FIGS. 1A-1B depict two perspective views of a spectral reader, according to an embodiment of the invention;

FIGS. 2A-2B show two perspective views of an optical assembly in reflectance configuration, according to an embodiment of the invention;

FIG. 3 shows a perspective view of an optical assembly in transmission configuration, according to an embodiment of the invention;

FIG. 4 depicts spectral radiation curves measured from eight illuminant sources configured from eight LEDs, according to an embodiment of the invention;

FIG. 5 shows spectral reflectance curves of several color samples measured by a spectral reader of the invention; and

FIG. 6 depicts separations in spectral curves of several color samples measured by a spectral reader of the invention.

DETAILED DESCRIPTION

[0010] Embodiments and accompanying drawings depicted in the following are provided by way of example to illustrate some general principles of the invention, and should not be construed as limiting the scope of the invention in any manner. One skilled in the art would also recognize that various changes and modifications can be made herein, without departing from the principles and scope of the invention.

[0011] FIGS. 1A-1B depict two perspective views of a spectral measuring device (termed "spectral reader" herein) 100, according to an embodiment of the invention. The spectral reader 100 comprises, as shown in a side view of FIG. 1A: an optical assembly 110; a circuit board 120 which may include a processor 122 and a memory 124; a power source 130 (e.g., one or more batteries); a power switch 135; an aperture 140; and optionally, a sample holder 150, in close proximity to the aperture 140. The spectral reader 100 may further comprise, as shown in the top view of FIG. 1B: a display panel 160; and a plurality of user-interface elements 170, including one or more navigation keys 172 and an execution key 174.

[0012] In the embodiment of FIGS. 1A-1B, the aperture 140 is in optical communication with the optical assembly 110 (as further illustrated in the following). The sample holder 150 is configured to allow an object (or sample) to be placed such that the sample is in the requisite optical communication with the optical assembly 110 via the aperture 140. As a way of example, the sample holder 150 is shown to have an "open" structure in FIG. 1A. In other embodiments, the sample holder 150 can also form a "closed" structure, e.g., configured to provide a dark enclosure to the sample contained therein. Further, the configuration may be such that the sample holder 150 is removable, or interchangeable. In some situations, the measurement may also be made without the aid of a sample holder, e.g., by placing the sample in direct contact with the aperture 140.

[0013] FIGS. 2A-2B show a side view and a top view of an optical assembly 200 in reflectance configuration, according to an embodiment of the invention. The optical assembly 200 may be used as an embodiment of the optical assembly 110 of FIG. 1A, for instance. The optical assembly 200 comprises: an illumination source which may include a plurality of LEDs 220; a plurality of LED tunnels 230, e.g., each associated with one or more of the LEDs 220; a sensor unit 240 which may include one or more optical sensors; a sensor tunnel 250; an aperture 260 (which may provide for the aperture 140 of FIG. 1A); and a

sample port 270. As an example to illustrate how various components are configured, a sample 280 is also shown. In one embodiment, the optical assembly 200 may be built on a mold component 210 that hosts its constituent elements, as shown in FIG. 2A. The mold component 210 may be for example made by way of casting, e.g., on a piece of plastics, or other suitable materials that have sufficiently low thermal expansion coefficients. In other embodiments, the LED tunnels 230 and/or the sensor tunnel 250 may be for example provided by one or more cylindrical structures (such as tubes), made of suitable materials (e.g., aluminum, chromium, plastic, etc.).

[0014] In one embodiment, the LED tunnels 230 may each be at a 45-degree angle relative to a normal direction 272 of the sample port 270. The LEDs 220 may each be disposed in one of the LED tunnels 230 and aimed at the sample 280. The sample 280 is disposed in close contact with the sample port 270, such that very little ambient light can get into the aperture 260. The LED tunnels 230 may have reflective inner-surfaces, so as to enhance the diffuse reflectivity inside the tunnels. In one embodiment, for example, the inner surfaces of the LED tunnels may be activated chemically to allow for deposition of a layer of metal (e.g., chromium). The deposition can be achieved using electrochemical processes (e.g., electroplating). As such, radiation emitted from the LEDs 220 is confined in the respective LED tunnels 230 and projected onto the sample 280. Some fraction of the LED radiation may reach the sample 280 after one or more surface reflections inside the LED tunnels 230. Such reflections help improve illumination efficiency of the LEDs and provide a uniform illumination on the sample.

[0015] The sensor tunnel 250 is configured to be in alignment with the aperture 260. The sensor unit 240 may be disposed inside the sensor tunnel 250 and in direct optical communication with the sample 280 via the aperture 260. The surface of the sensor tunnel 250 and the surrounding of the aperture 260 may be treated such to minimize light reflection (e.g., by applying an anti-reflection coating).

[0016] The LEDs 220 may include a plurality of LEDs that have different types, and/or spectral characteristics. In some embodiments, different LEDs may be effectively obtained by altering spectral characteristics of one or more LEDs via suitable means, such as by applying one or more optical filters, and/or by changing the operating current. In this manner, a plurality of LEDs can be effectively constructed from, at least, one LED. The

LEDs **220** may be selected such that the combined radiation spectrum of the LEDs **220** covers a particular wavelength range of interest, as further described below. In one embodiment, the LEDs **220**, along with the sensor unit **240**, may be in communication with and controlled by the circuit board **120** of FIG. **1A**.

[0017] In a measurement process, the sample **280** is illuminated by the LEDs **220**. The light reflected from the sample **280** is detected by the sensor unit **240**. The sensor unit **240** converts the detected optical signals into corresponding electrical signals, which in one example may be associated with the intensity of the reflected light from the sample **280** under the illumination of LEDs **220**. The sensor unit **240** outputs the electrical signals to the circuit board **120** of FIG. **1A**, for example. The measured results may be presented by one or more numerical readings and/or graphic displays, e.g., shown on the display panel **160** of FIG. **1B**.

[0018] FIG. **3** depicts a perspective side view of an optical assembly **300** in transmission configuration, according to an embodiment of the invention. The optical assembly **300** may be alternatively used to embody the optical assembly **110** of FIGS. **1A-1B**, for instance. The optical assembly **300** may likewise be built on a mold component **310**. In this case, a plurality of LEDs **320** may be disposed in the respective LED tunnels **330**, e.g., in a manner similar to what is shown in FIGS. **2A-2B**. Light radiated from the LEDs **320** may be collimated by a lens **340**, subsequently pass through an aperture **350**, and then be incident on a sample **360** in a sample port **370**. A sensor unit **380** including one or more optical sensors is disposed on the transmission side of the sample port **370**, to detect the transmitted light from the sample **360**. The LEDs **320**, along with the sensor unit **380**, may be in communication with and controlled by the circuit board **120** of FIGS. **1A**, in one embodiment.

[0019] As a way of example to illustrate some general principles of the invention, the following description is presented with respect to a spectral reader operating in reflectance configuration (e.g., having an optical assembly as shown in FIGS. **2A-2B**). It will be appreciated that the principles of the invention and the results thus obtained can also be applied to other spectral readers operating in transmission configuration (e.g., having an optical assembly as shown in FIG. **3**).

[0020] The radiation intensity of an LED can be presented as a spectral curve peaked at a characteristic center wavelength. When a sample is illuminated by a single LED, the output of a sensor that collects the reflected (or transmitted) light from the sample includes three major components: 1) the spectral characteristics of the sample; 2) the spectral radiation curve of the LED; and 3) the spectral response function of the sensor.

[0021] When a sample is illuminated by a plurality of LEDs, a complete sample measurement may constitute a sequence of measurements performed under a plurality of linearly independent illuminant sources constructed from the LEDs. In one embodiment, for example, N (e.g., $N \geq 2$) linearly independent illuminant sources are constructed from various combinations of N LEDs (which can make use of those available commercially). Thus, the sample is effectively illuminated by N linearly independent illuminant sources thus created, and N measurements can be collected in a complete sample measurement. Dividing the wavelength range of interest into N wavelength channels (e.g., each wavelength channel corresponding with a particular color), the sample's reflectance (or transmittance) values in the N wavelength channels can be determined from the N measurements, as further described below.

[0022] In one embodiment, a spectral reader of the invention may be characterized (e.g., at the factory) by use of a "characterization sample," whereby the spectral radiation curves of N illuminant sources can be obtained. The characterization process may be carried out, for example, by using a standard white sample (or an integrating sphere, e.g., a hollow sphere with an inner surface having a sufficiently high diffusive reflectivity) as the characterization sample, an external spectral analyzer (such as a spectrometer) with adequate spectral resolution, and an external computing device (e.g., a computer).

[0023] In one embodiment of a characterization process, the standard white sample is illuminated in turn by N linearly independent illuminant sources constructed from N LEDs used in a spectral reader of interest. The light reflected from the surface of the standard white sample is measured by the external spectral analyzer, and the spectral radiation curve of each illuminant source is recorded. By way of example, FIG. 4 shows spectral radiation curves measured from a system of eight independent illuminant sources, covering a wavelength range approximately from 400nm to 700nm. In this case, eight linearly independent illuminant sources are constructed from eight LEDs (e.g., by using various combinations of

one or more LEDs selected therefrom). For purposes of illustration and clarity, the spectral radiation curves are shown by alternate solid and dashed lines in FIG. 4.

[0024] The measured spectral radiation curves of the independent illuminant sources can be used to construct an "Illuminant Characterization Matrix" (or "Source Characterization Matrix") which can be stored in the spectral reader (e.g., in the memory 124 of FIG. 1A). The following provides an embodiment of how an Illuminant Characterization Matrix can be computed.

[0025] Suppose that N LEDs are used in a spectral reader. Divide the wavelength range covered these LEDs into N wavelength channels, each occupying a wavelength range from λ_{j-1} to λ_j ($\lambda_j > \lambda_{j-1}$, $j = 1, 2, \dots, N$). The wavelength channels may have unequal widths.

[0026] The average intensity of the i th illuminant source in the j th wavelength channel can be expressed as

$$I_{ij} = \frac{1}{\lambda_j - \lambda_{j-1}} \cdot \int_{\lambda_{j-1}}^{\lambda_j} I_i(\lambda) d\lambda; \quad i = 1, 2, \dots, N; \quad j = 1, 2, \dots, N. \quad \text{Eq. (1)}$$

where $I_i(\lambda)$ is the spectral radiation curve of the i th illumination source measured by the external spectral analyzer.

[0027] When the above calculation is performed with respect to N wavelength channels and N illuminant sources, an $N \times N$ matrix, $\overset{\vee}{I}$, is thus constructed. The inversion of this matrix, termed "Illuminant Characterization Matrix" (or "Source Characterization Matrix") herein, can be shown as

$$\overset{\tau}{J} = \overset{\tau}{I}^{-1} = [\overset{\vee}{I}_{ij}]^{-1}. \quad \text{Eq. (2)}$$

The above calculations can be performed by the external computing device. The Illuminant Characterization Matrix $\overset{\vee}{J}$ thus obtained is then stored in the spectral reader.

[0028] To obtain the reflectance (or transmittance) values of a sample in the N wavelength channels of interest, the spectral reader needs to be calibrated, e.g., by use of one or more "calibration samples." In one embodiment, a substantially white (or "light") sample and a

substantially black (or “dark”) sample may serve as the calibration samples. In alternative embodiments, a single white (or “light”) sample may also be used for the calibration purpose. The calibration process may be performed at the factory, and the calibration data thus obtained are stored in the spectral reader. The calibration process may also be performed by the user, e.g., before making a measurement or whenever it is deemed useful.

[0029] Consider a calibration process involving white and black calibration samples. The spectral reader performs a sequence of measurements on each calibration sample. The measured data, which may include for example N “black calibration readings” and N “white calibration readings,” can be represented by

$$\vec{V}_B^{\otimes} = \begin{pmatrix} V_{B1} \\ V_{B2} \\ M \\ V_{BN} \end{pmatrix} \text{ and } \vec{V}_W^{\otimes} = \begin{pmatrix} V_{W1} \\ V_{W2} \\ M \\ V_{WN} \end{pmatrix}, \quad \text{Eq. (3)}$$

where the subscripts “ B ” and “ W ” stand for the black sample and the white sample, respectively. The calibration data of Eq. (3), in conjunction with the Illuminant Characterization Matrix of Eq. (2), are used to determine the reflectance values of a sample in the respective wavelength channels of interest, as further described below.

[0030] In a subsequent sample measurement (e.g., performed by a user), the reading of the sensor unit under the i th illumination source can be expressed as

$$V_i = A \cdot \sum_{j=1}^N I_{ij} \cdot R_j \cdot G_j + V_{Bi}; \quad i = 1, 2, \dots, N, \quad \text{Eq.(4)}$$

where A represents an instrument-related constant, R_j represents the average reflectance (or transmittance) of the sample in the j th wavelength channel, G_j is the average sensitivity of the sensor unit in the j th wavelength channel, V_{Bi} is the black calibration reading under the i th illuminant source (which may also include contributions from ambient environment), and I_{ij} is the average intensity of the i th illumination source in the j th wavelength channel.

[0031] Eq.(4) can be represented by a $N \times N$ linear system:

$$\vec{V}^{\omega} = \vec{F}^{\omega} \cdot \vec{I}^{\tau} + \vec{V}_B^{\omega}, \quad \text{Eq. (5)}$$

where

$$\vec{V}^{\omega} = \begin{pmatrix} V_1 \\ V_2 \\ M \\ V_N \end{pmatrix}, \vec{F}^{\omega} = \begin{pmatrix} AG_1 R_1 \\ AG_2 R_2 \\ M \\ AG_N R_N \end{pmatrix}, \text{ and } \vec{I}^{\tau} = \begin{pmatrix} I_{11} & I_{12} & \Lambda & I_{1N} \\ I_{21} & I_{22} & \Lambda & I_{2N} \\ M & M & O & M \\ I_{N1} & I_{N2} & \Lambda & I_{NN} \end{pmatrix}. \quad \text{Eq. (6)}$$

Eq.(5) can be further expressed as

$$\vec{F}^{\omega} = \vec{I}^{\tau^{-1}} \cdot (\vec{V}^{\omega} - \vec{V}_B^{\omega}) = \vec{J}^{\tau} \cdot (\vec{V}^{\omega} - \vec{V}_B^{\omega}) \quad \text{Eq. (7)}$$

where \vec{J}^{τ} is the Illuminant Characterization Matrix in Eq.(2):

$$\vec{J}^{\tau} = \vec{I}^{\tau^{-1}} = \begin{pmatrix} J_{11} & J_{12} & \Lambda & J_{1N} \\ J_{21} & J_{22} & \Lambda & J_{2N} \\ M & M & O & M \\ J_{N1} & J_{N2} & \Lambda & J_{NN} \end{pmatrix}. \quad \text{Eq. (8)}$$

Eq.(7) can be written as

$$AG_i R_i = \sum_{j=1}^N J_{ij} \cdot (V_j - V_{Bj}); \quad i = 1, 2, \Lambda, N. \quad \text{Eq. (9)}$$

As is in general practice, the reflectance value of a sample may be normalized in reference to the reflectance value of the white calibration sample. For the sake of simplicity, the reflectance value of the white calibration sample is defined as unity (or "1") in each wavelength channel of interest. Thus, when the measured sample is the white sample, Eq.(9) becomes

$$AG_i = \sum_{j=1}^N J_{ij} \cdot (V_{Wj} - V_{Bj}); \quad i = 1, 2, \Lambda, N, \quad \text{Eq. (10)}$$

where V_{Wj} is shown in Eq.(3) above.

[0032] Combining Eqs. (9) and (10) above, the reflectance values of the sample in each wavelength channel can be shown as

$$R_i = \frac{\sum_{j=1}^N J_{ij} \cdot (V_j - V_{Bj})}{\sum_{j=1}^N J_{ij} \cdot (V_{Wj} - V_{Bj})}, \quad i = 1, 2, \dots, N. \quad \text{Eq.(11)}$$

[0033] The description above is presented with respect to an embodiment in which N linearly independent illuminant sources and N wavelength channels are constructed. In alternative embodiments, N illuminant sources and M ($M \geq 2$) wavelength channels can also be used. In such case, the Illuminant Characterization Matrix in Eq.(2) or Eq.(8) may be calculated, e.g., using the standard Least-square Method for $M < N$ cases and the Singular Value Decomposition (SVD) method for $M > N$ cases, and will have a dimension of $M \times N$. Accordingly, the reflectance in Eq. (11) will have M components. Those skilled in the art will recognize, however, that these methods of computation are substantially equivalent.

[0034] By way of example, FIG. 5 shows spectral reflectance curves of four test samples measured by a spectral reader of the invention that makes use of the eight illuminant sources (i.e., $N = 8$) shown in FIG. 4 and sixteen wavelength channels (i.e. $M = 16$). The four test samples are selected from PANTON color patches known in the art: 331U, 332U, 333U and PANTON Green. A skilled artisan will appreciate the quality of the spectral reflectance curves presented in FIG. 5.

[0035] A spectral reader of the invention can further distinguish colors by their spectral characteristics. By way of example, FIG. 6 shows spectral reflectance curves measured from seven PANTON brown color patches known in the art: 462U, 463U, 464U, 465U, 466U, 467U and 468U. It is known that the differences between some of these colors are so small to be distinguished visually. However, these colors are clearly separated from one other in their reflectance curves measured by a spectral reader of the invention.

[0036] The description and analysis above are presented with respect to a spectral reader operating in reflectance configuration. When a spectral reader is operating in transmission

configuration, it needs to be calibrated using a transparent sample. In terms of the equations derived above for the reflectance case, the components of \check{V}_B^w and \check{V}_W^w in Eq.(3) should be replaced with zeros and the readings obtained from a transparent calibration sample, respectively. Substituting these new values for \check{V}_B^w and \check{V}_W^w in Eq.(11), $R_i, i = 1, 2, \Lambda, N$, become the spectral transmittance values of the sample in the N wavelength channels.

[0037] In one embodiment, a spectral reader of the invention may be preloaded (e.g., at the factory, or by the user) with various standard data tables (e.g., in the memory 124 of FIG. 1A), such as CIE 1964 Standard Colorimetric Observer table and D65 Illuminant table known in the art. In this way, the spectral reader can also provide tristimulus values, or any standard color coordinates (e.g., CIELab), from the measured spectral curves.

[0038] In one embodiment, a spectral reader may be configured to measure, determine, and record the color coordinates of one sample serving as a "target." When a new measurement is made on another sample, the spectral reader can provide the color differences, such as the CIELab or CMC color differences, based on the newly calculated color coordinates and those of the target.

[0039] In one embodiment, a spectral reader may be configured to perform and record measurements on one or more "reference" samples, and a numerical value (or other non-numerical representation) for example is associated with each measurement according to a pre-determined scheme (e.g., by constructing an appropriate model). When measuring a new (or unknown) sample, the spectral reader can then evaluate the new measurement based on the stored reference data, e.g., by deriving a corresponding numerical value or non-numerical presentation for the unknown sample based on the model.

[0040] In one embodiment, a spectral reader may also include an internal clock (or "timer"), for example, to provide the time and date when a measurement is taken. A spectral reader of the invention may present and store its measurements in the form of spectral reflectance (or transmittance) values, spectral tristimulus values, standard color coordinates, standard color differences, numerical test values, or other non-numerical test representation. It may further allow the user to choose a particular form for presenting the measurement result, or view the measurement result in different forms, including (but not limited to) a time sequence form.

[0041] Referring back to FIGS. 1A-1B. The processor 122 can include, for example, a digital logical processor, a microprocessor, an Application Specific Integrated Circuit (ASIC), or any other means capable of processing input data, executing algorithms, and generating output data in a desired form. The memory 124 may be the embedded (or “on-chip”) memory in the processor 122, storing (e.g., in firmware) the Illuminant characterization matrix of Eq. (8), the calibration data of Eq.(3), and instructions/algorithms for carrying out various measurements and computations. The memory 124 may also be “external” to the processor 122, providing additional memory (e.g., for storing the preloaded data and other relevant information). The circuit board 120 may be further equipped with data transfer capabilities, so as to allow the user to download or upload information, save the measurement result on other devices, such as user’s home computer, and/or perform additional analysis on the collected data. The sensor unit 240 may include one or more sensors with different spectral response functions. The sensor unit 240 may also be provided by a Charge-Coupled Device (CCD) array.

[0042] Those skilled in the art will appreciate that by making use of LEDs and constructing a Illuminant characterization matrix as described above, a spectral reader of the invention affords accurate color determination and compact structure, hence applicable in a variety of consumer and industrial applications. For example, spectral readers of the invention can be configured as handheld testers for performing a variety of biomedical tests in laboratories or consumer’s households. Such applications include (but are not limited to) quantitative analysis of nucleic acids, proteins and antibodies; routine health diagnostic and monitoring analysis such as urine tests and other bodily fluid analysis; food additive and contaminant analysis; forensic analysis; and so on. Spectral readers of the invention can also be configured as handheld color measuring devices that can for example provide quantitative and convenient measurements of paint, ink, dyes, cosmetics, and other color related products, as well as improve upon the existing color related products (such as pH papers and SND sticks).

[0043] In the above, examples are given in the visible wavelength range. Such should not be construed as limiting the scope of the invention in any manner, however. The principles of the invention can also be used to construct spectral readers operating in other wavelength ranges, such as the infrared and ultraviolet wavelength ranges. In one embodiment, a

plurality of radiation sources (such as LEDs) may have overlapping spectra, and the wavelength channels thus formed may be continuous in a particular wavelength range. In other embodiments, the radiation sources (such as LEDs) may have discrete spectra, and the wavelength channels thus formed may also be discrete in a particular wavelength range. The principles and results of the invention (e.g., Eqs. (1) – (11) above), however, are applicable to such cases.

[0044] The foregoing description of the embodiments of the invention has been presented only for the purpose of illustration and description and is not intended to be exhaustive or to limit the invention to the precise forms disclosed. Numerous modifications and adaptations thereof will be apparent to those skilled in the art without departing from the spirit and scope of the present invention.

WHAT IS CLAIMED IS:

1. An apparatus, comprising:
 - at least one radiation source configured to provide N ($N \geq 2$) independent illuminant sources characterized by M ($M \geq 2$) wavelength channels in a predetermined wavelength range;
 - a sensor unit including at least one optical sensor, the sensor unit configured to be in optical communication with the at least one radiation source and a sample;
 - a memory storing an illuminant characterization matrix having spectral characteristics of the N illuminant sources in the M wavelength channels; and
 - a processor in communication with the sensor unit and the memory, the processor configured to provide spectral responses of the sample in the M wavelength channels based at least in part on the illuminant characterization matrix.
2. The apparatus of claim 1 wherein the memory further comprises calibration data associated with a substantially white sample in the predetermined wavelength range, the processor configured to provide spectral responses of the sample in the M wavelength channels based at least in part on the illuminant characterization matrix and the calibration data.
3. The apparatus of claim 1 wherein the spectral responses of the sample include reflectance values of the sample in the M wavelength channels.
4. The apparatus of claim 1 wherein the spectral responses of the sample include transmittance values of the sample in the M wavelength channels.
5. The apparatus of claim 1 wherein M equals to N .
6. The apparatus of claim 1 wherein the memory further comprises program code for performing a calibration associated with at least one calibration sample in the predetermined wavelength range.

7. The apparatus of claim 1 wherein the at least one radiation source include at least one light emitting diode (LED).
8. The apparatus of claim 1 wherein the sensor unit includes at least one photodiode.
9. The apparatus of claim 1 wherein the sensor unit includes a Charge-Coupled Device (CCD) array.
10. The apparatus of claim 1 wherein the processor is further configured to cause a presentation associated with the spectral responses of the sample to be displayed on a display panel.
11. The apparatus of claim 1 further comprising at least one user-interface element.
12. The apparatus of claim 1 further comprising a data transfer means in communication with the processor.
13. An apparatus, comprising:
 - a sample;
 - at least one radiation source configured to provide N ($N \geq 2$) independent illuminant sources characterized by M ($M \geq 2$) wavelength channels in a predetermined wavelength range;
 - a sensor unit including at least one optical sensor, configured to be in optical communication with the radiation sources and the sample;
 - a memory, storing an illuminant characterization matrix having spectral characteristics of the N illuminant sources in the M wavelength channels; and
 - a processor in communication with the sensor unit and the memory, configured to provide spectral responses of the sample in the M wavelength channels, based at least in part on the illuminant characterization matrix.
14. The apparatus of claim 13 wherein the memory further comprises calibration data associated with a substantially white sample in the predetermined wavelength range, the

processor configured to provide spectral responses of the sample in the M wavelength channels based at least in part on the matrix and the calibration data.

15. The apparatus of claim 14 wherein the memory further comprises calibration data associated with a substantially black sample, the processor configured to provide spectral responses of the sample in the M wavelength channels based at least in part on the matrix, the calibration data associated with the substantially white sample, and the calibration data associated with the substantially black sample.

16. The apparatus of claim 13 the spectral responses of the sample include reflectance values of the sample in the M wavelength channels.

17. The apparatus of claim 13 wherein the spectral responses of the sample include transmittance values of the sample in the M wavelength channels.

18. The apparatus of claim 13 wherein the memory further comprises program code for performing a calibration associated with at least one calibration sample in the predetermined wavelength range.

19. The apparatus of claim 13 further comprising a reference table containing spectral responses of a plurality of reference samples and color characteristics associated with the reference samples.

20. The apparatus of claim 19 wherein the processor is configured to provide color characteristics of the sample, based at least in part on the spectral responses of the sample and the reference table according to a predetermined scheme.

21. The apparatus of claim 13 wherein the at least one radiation source includes at least one light emitting diode (LED).

22. The apparatus of claim 13 wherein the processor is further configured to cause a presentation associated with the spectral responses of the sample to be displayed on a display panel.

23. The apparatus of claim 13 further comprising at least one user-interface element.
24. The apparatus of claim 13 wherein the memory further comprises at least one standard data table for color coordinates determination.
25. The apparatus of claim 24 wherein the processor is further configured to provide standard color coordinates of the sample.
26. The apparatus of claim 13 further comprising a data transfer means, in communication with the processor.
27. A method, comprising:
 configuring at least one radiation source to provide N ($N \geq 2$) independent illuminant sources characterized by M ($M \geq 2$) wavelength channels in a predetermined wavelength range;
 providing a sensor unit including at least one optical sensor, the sensor unit configured to be in optical communication with the radiation sources and a sample;
 storing in a memory an illuminant characterization matrix having spectral characteristics of the N illuminant sources in the M wavelength channels; and
 providing a processor in communication with the sensor unit and the memory, the processor configured to provide spectral responses of the sample in the M wavelength channels, based at least in part on the illuminant characterization matrix.
28. The method of claim 27 further comprising storing in the memory calibration data associated with a substantially white sample in the predetermined wavelength range, the processor configured to provide spectral responses of the sample in the M wavelength channels based at least in part on the illuminant characterization matrix and the calibration data.
29. The method of claim 27 further comprising providing a display panel in communication with the processor.

30. The method of claim 27 further comprising providing at least one user-interface element.

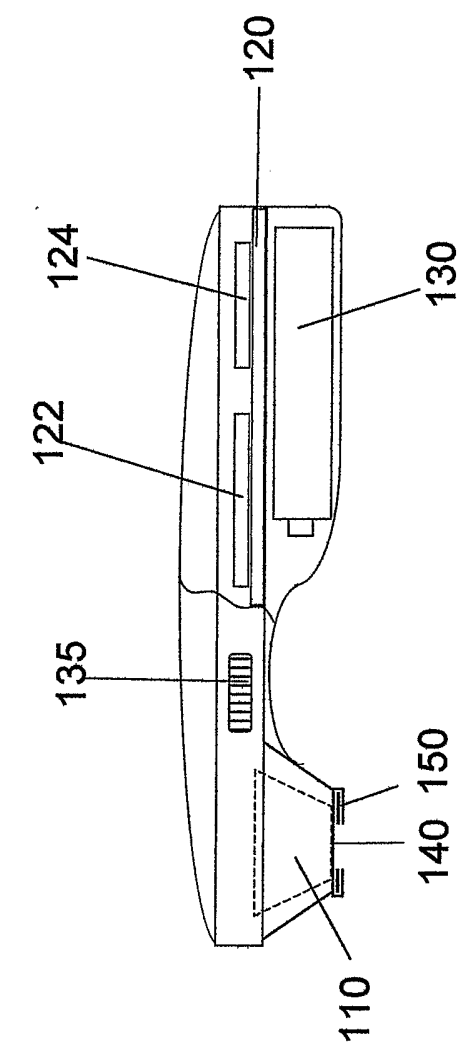

FIG. 1A

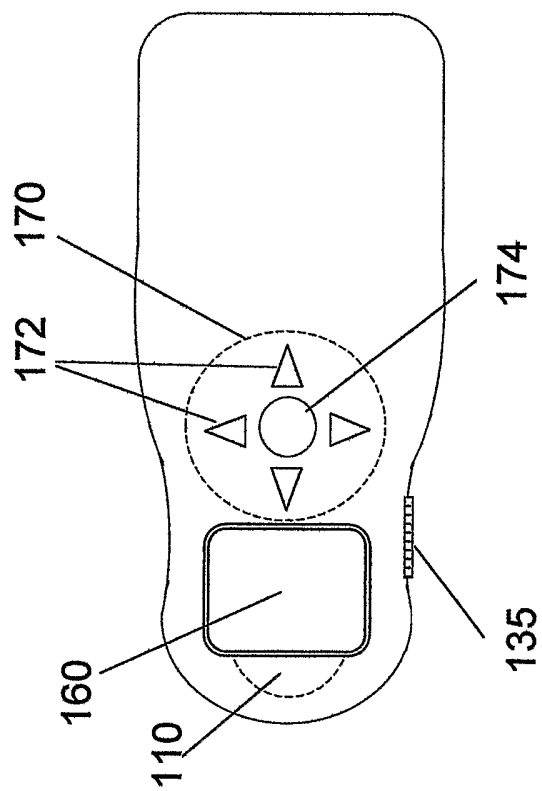
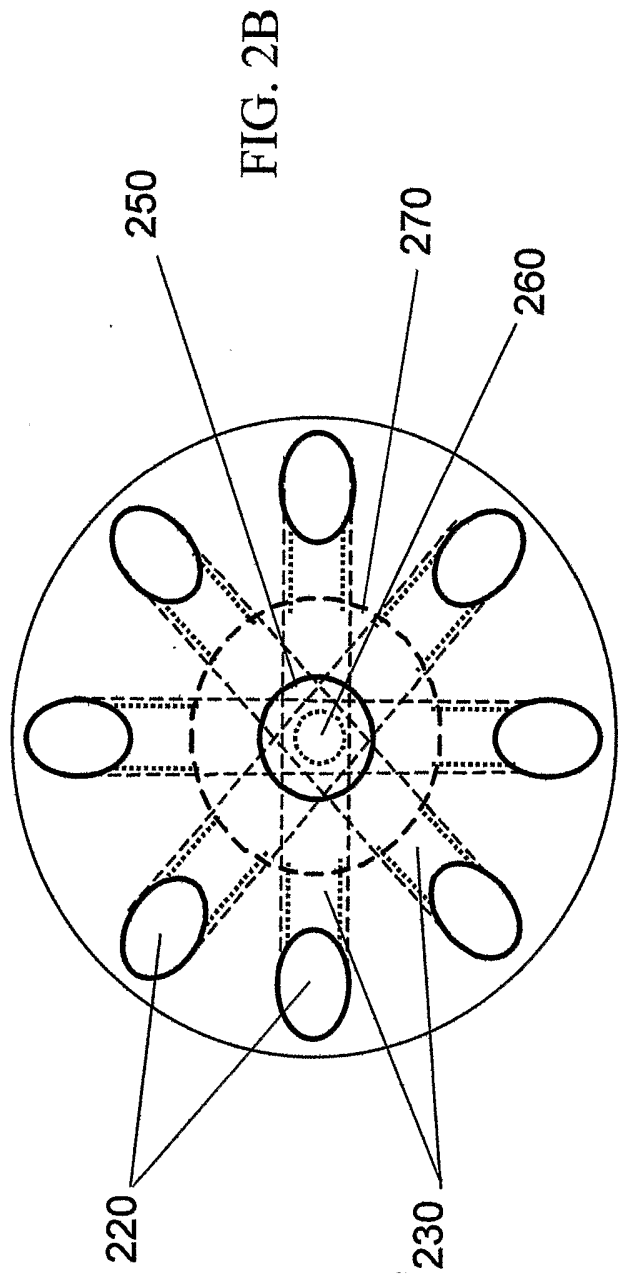
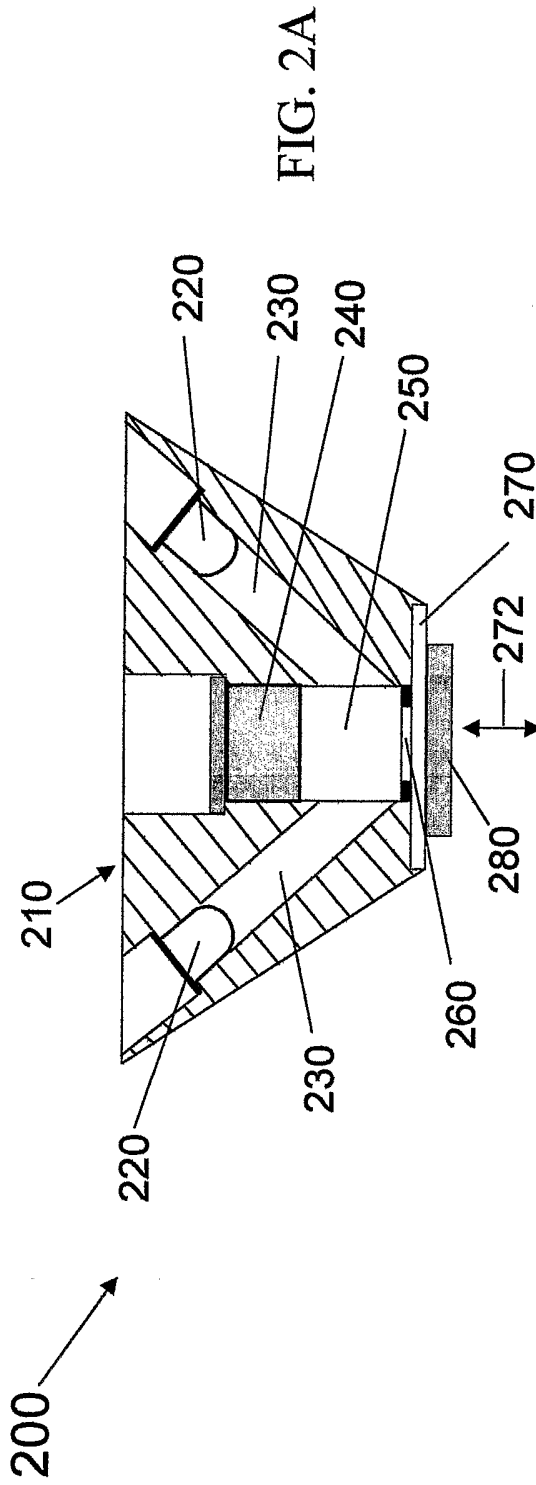

FIG. 1B



3/6

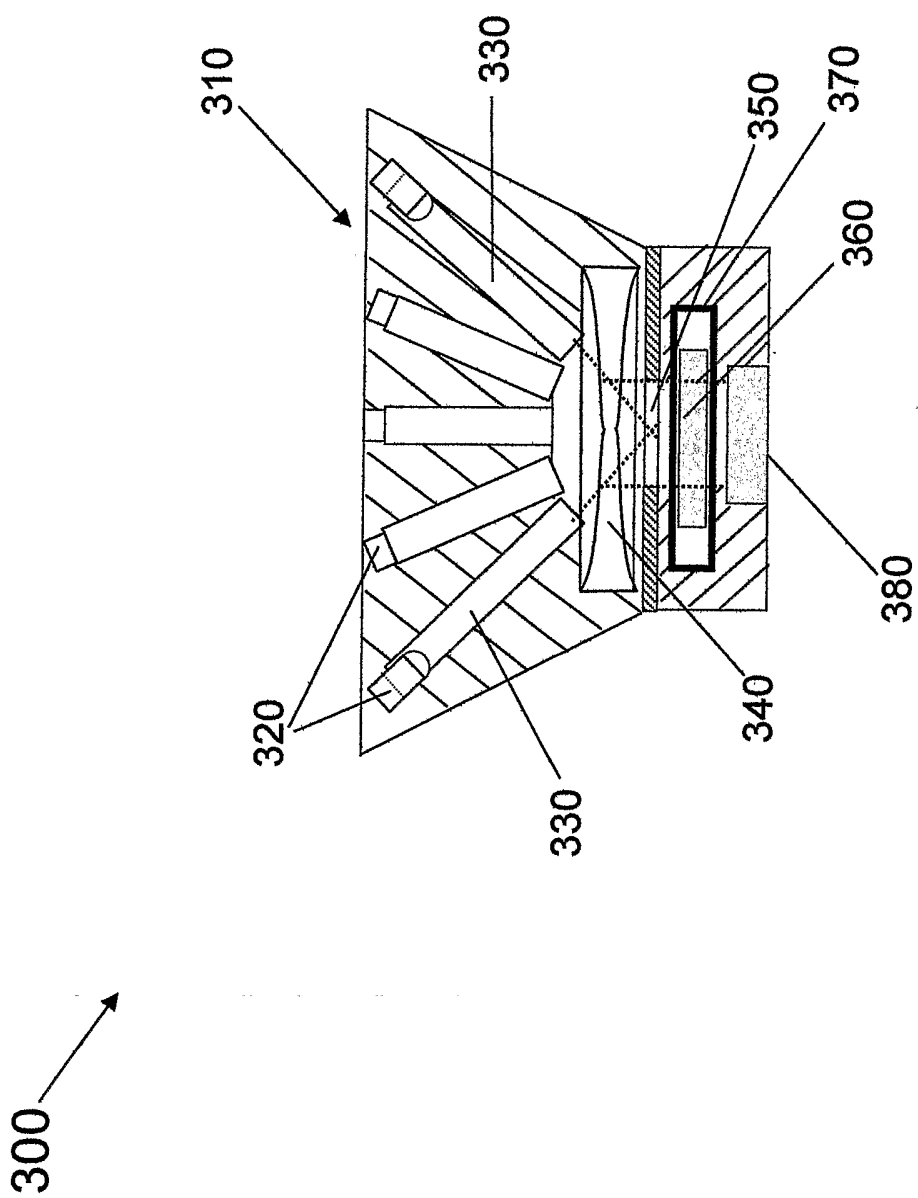

FIG. 3

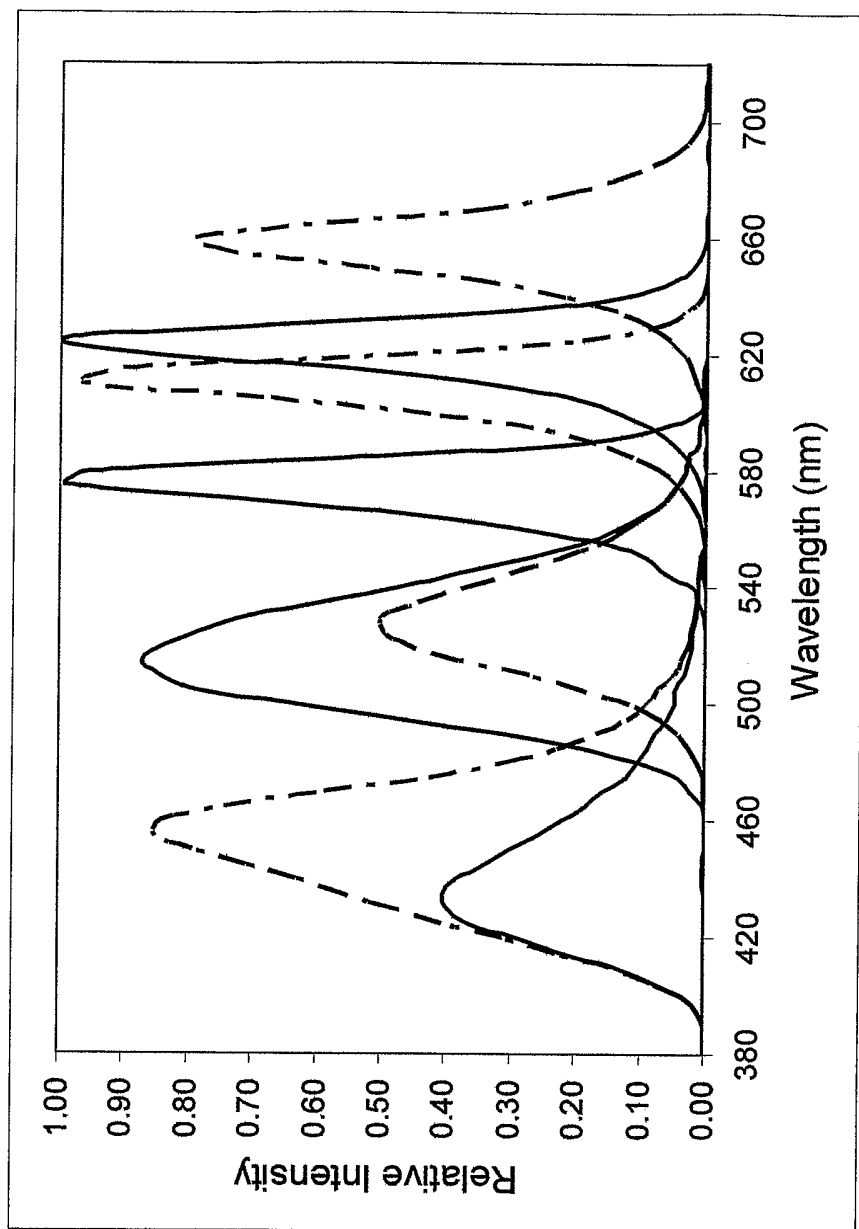

FIG. 4

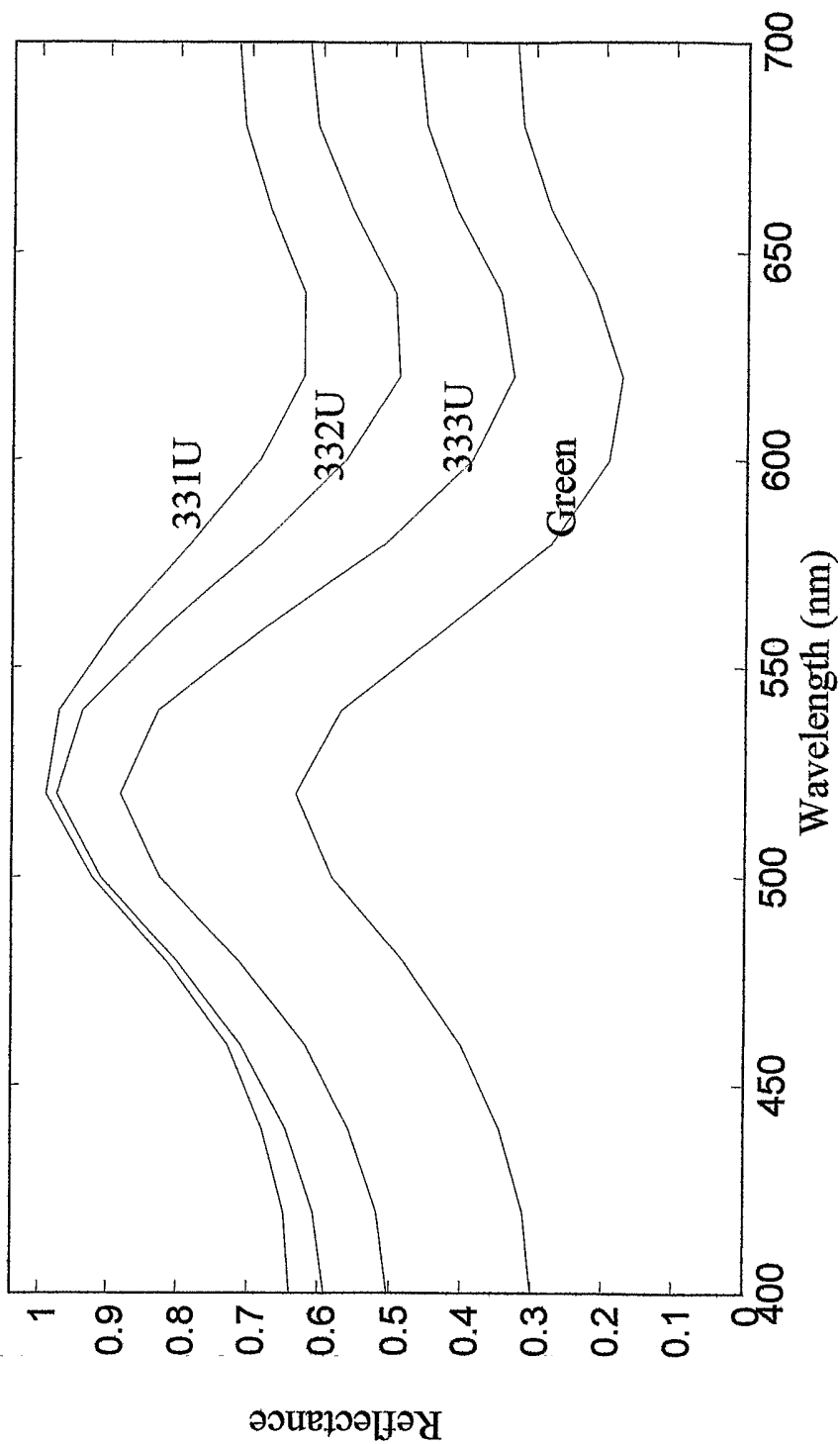

FIG. 5

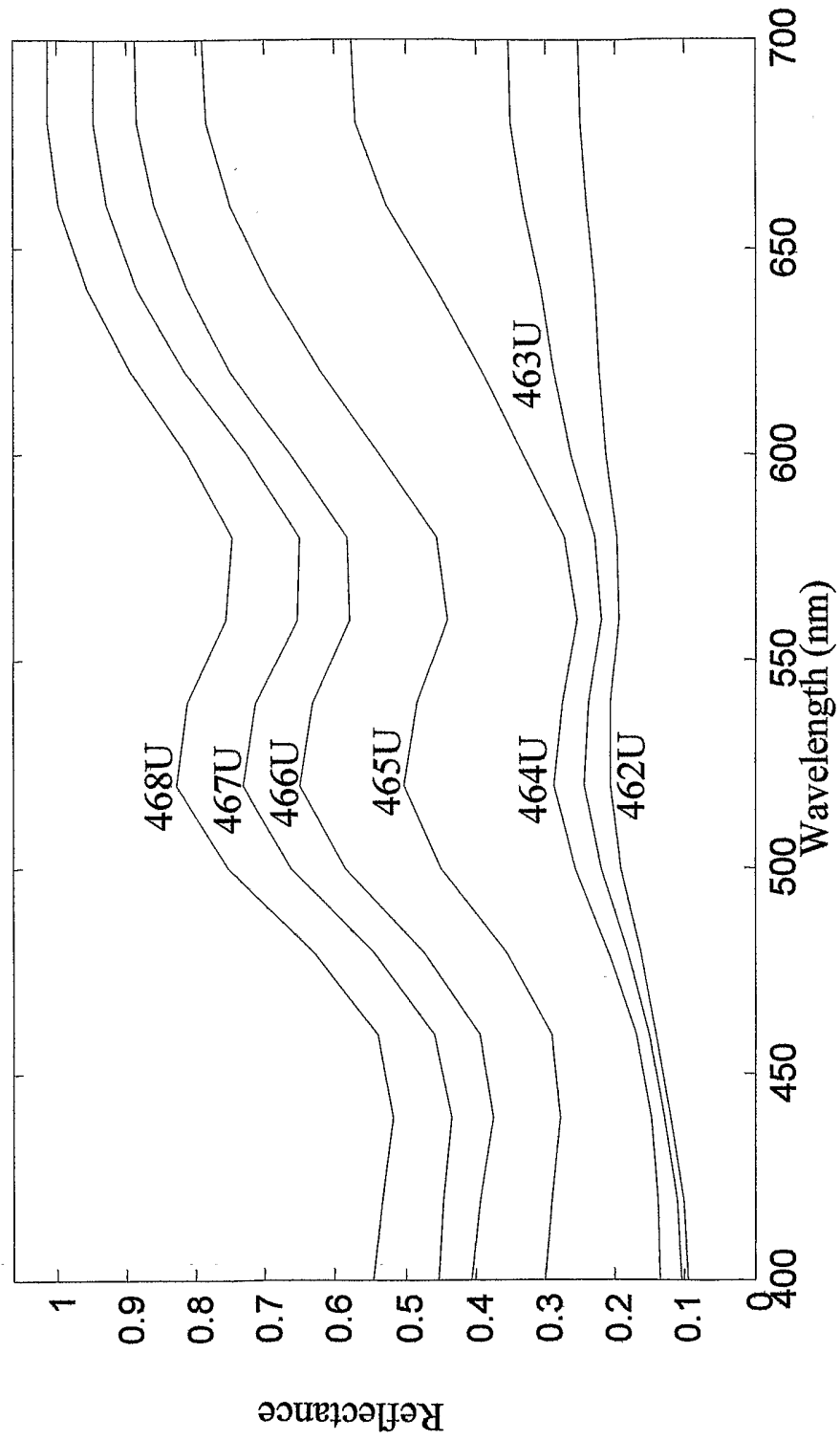

FIG. 6