



(19) **United States**

(12) **Patent Application Publication**

How et al.

(10) **Pub. No.: US 2003/0171079 A1**

(43) **Pub. Date: Sep. 11, 2003**

(54) **METHOD AND APPARATUS OF OBTAINING SUCTION CONTROL OVER SURFACE CLEANING AND SCRAPING**

(57)

ABSTRACT

(76) Inventors: **Hoton How**, Belmont, MA (US);
Yung-Ching Chu, Tao Yuan (TW)

Correspondence Address:

Hoton How
262 Clifton Street
Belmont, MA 02478 (US)

(21) Appl. No.: **10/092,000**

(22) Filed: **Mar. 7, 2002**

Publication Classification

(51) **Int. Cl.⁷** **B24B 1/00; B24B 23/00; B24B 41/06**

(52) **U.S. Cl.** **451/53; 451/344; 451/385; 451/359**

Disclosed is a method and two apparatuses enabling suction control over surface cleaning and scraping. Suction control is necessary so as to obtain good contact between a cleaning/scraping pad and the surface to be cleaned/scraped, thereby achieving efficiency. Also, suction control is required so as to collect debris falling off during the cleaning/scraping process, which may otherwise contaminate the environment. Suction control provides guidance for the movement of a cleaning/scraping pad sucked on the surface of an object. This implies convenience when cleaning/scraping over a large surface area is attempted. Suction action is generated by convecting away surrounding fluid, being either water or air, to produce local negative pressure at the pad position. The disclosed devices are most desirable in cleaning water containers, such as a fish tank or a swimming pool, as well as to collect dusts on scraping the surface of a mortar wall.

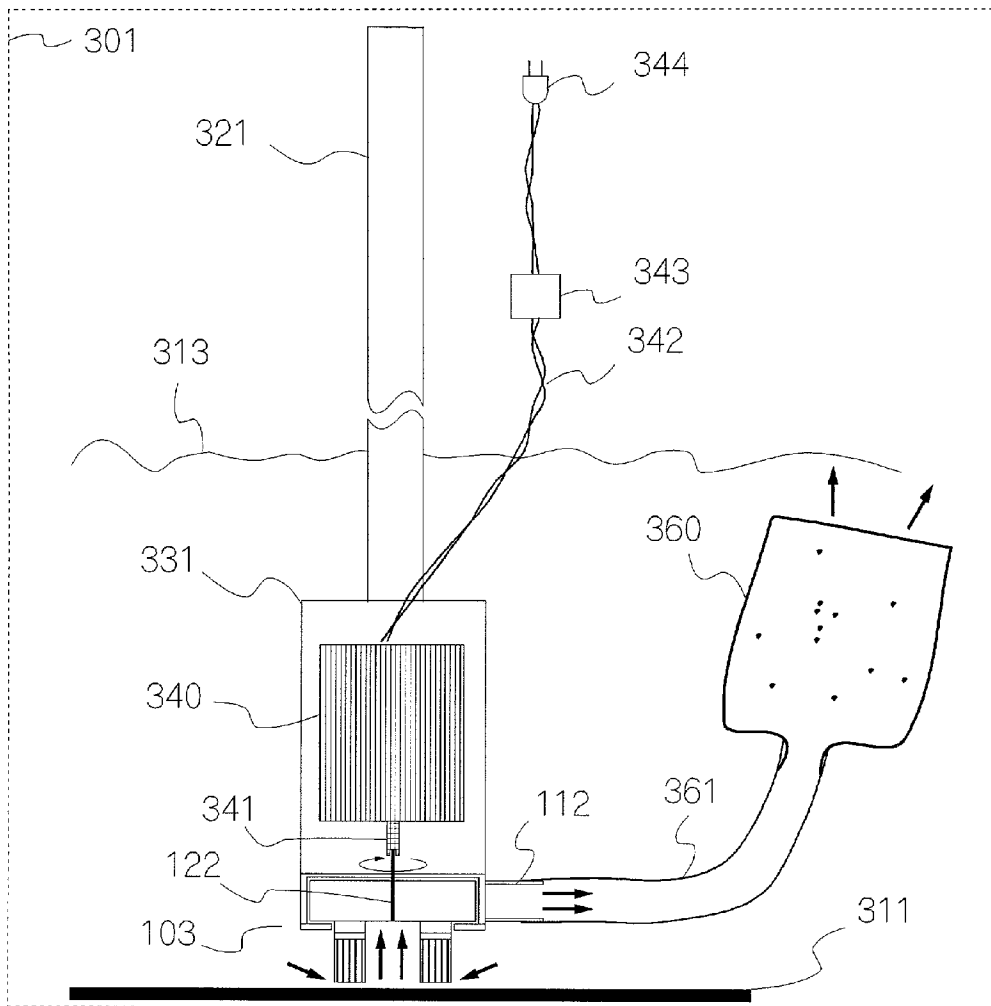

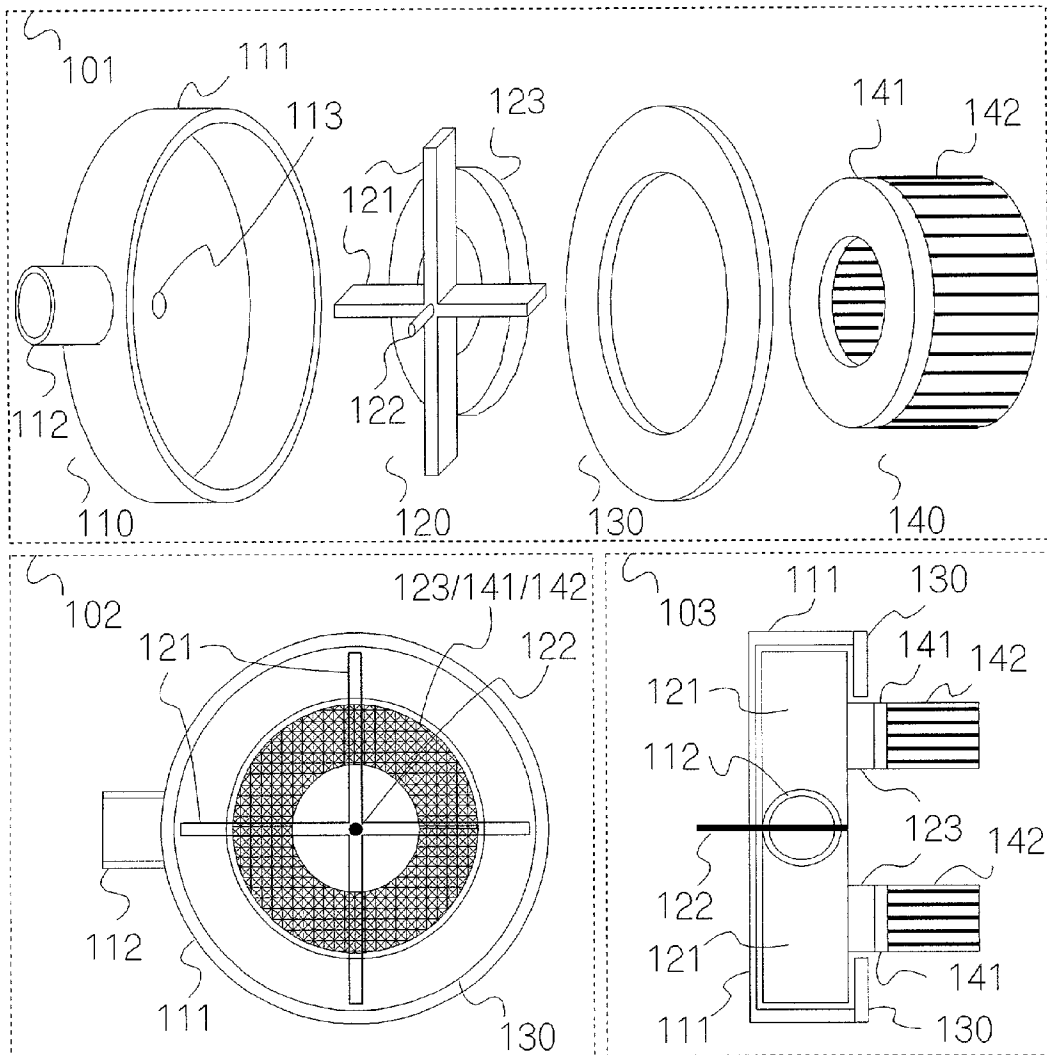

FIG. 1A

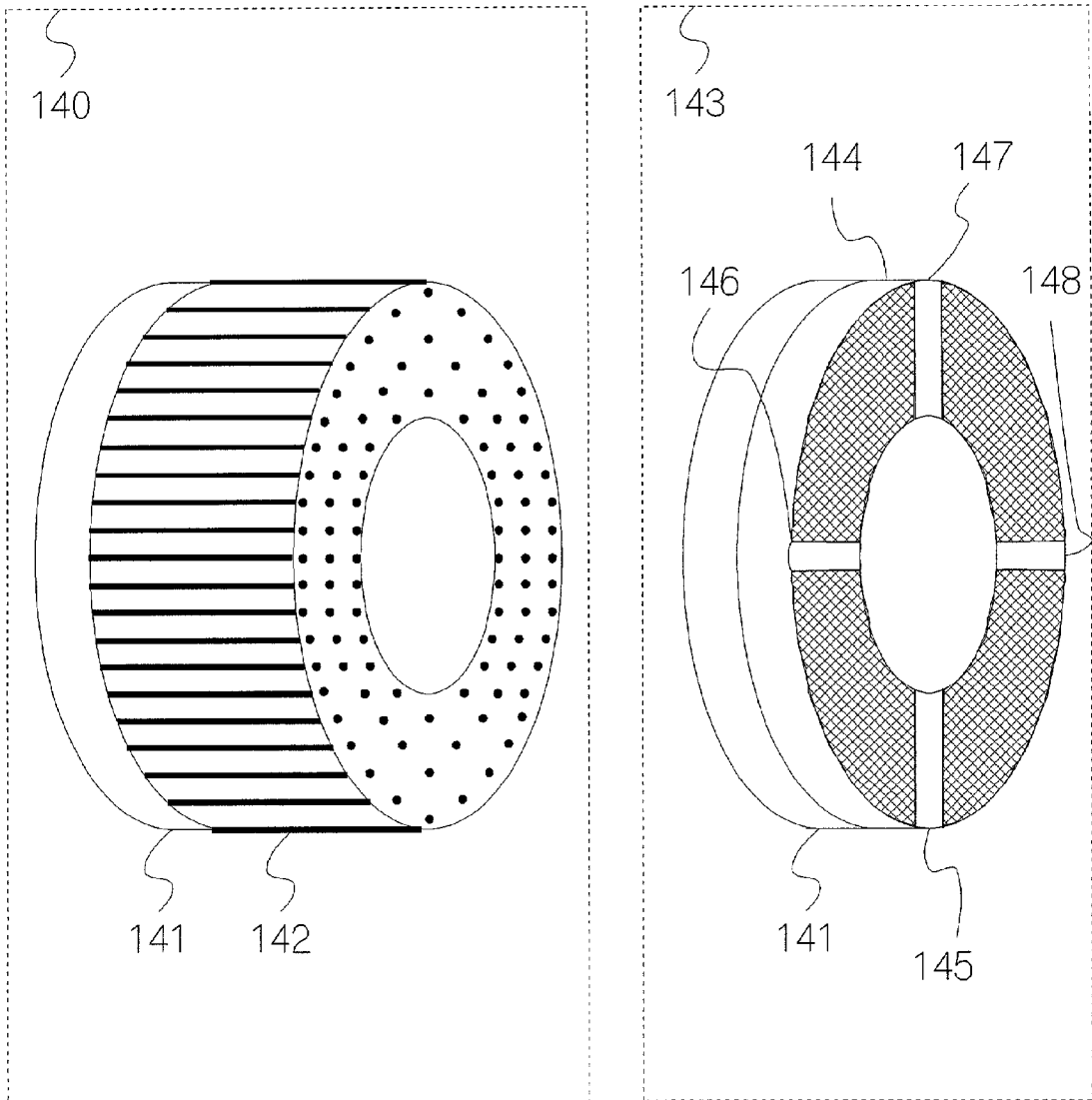

FIG. 1B

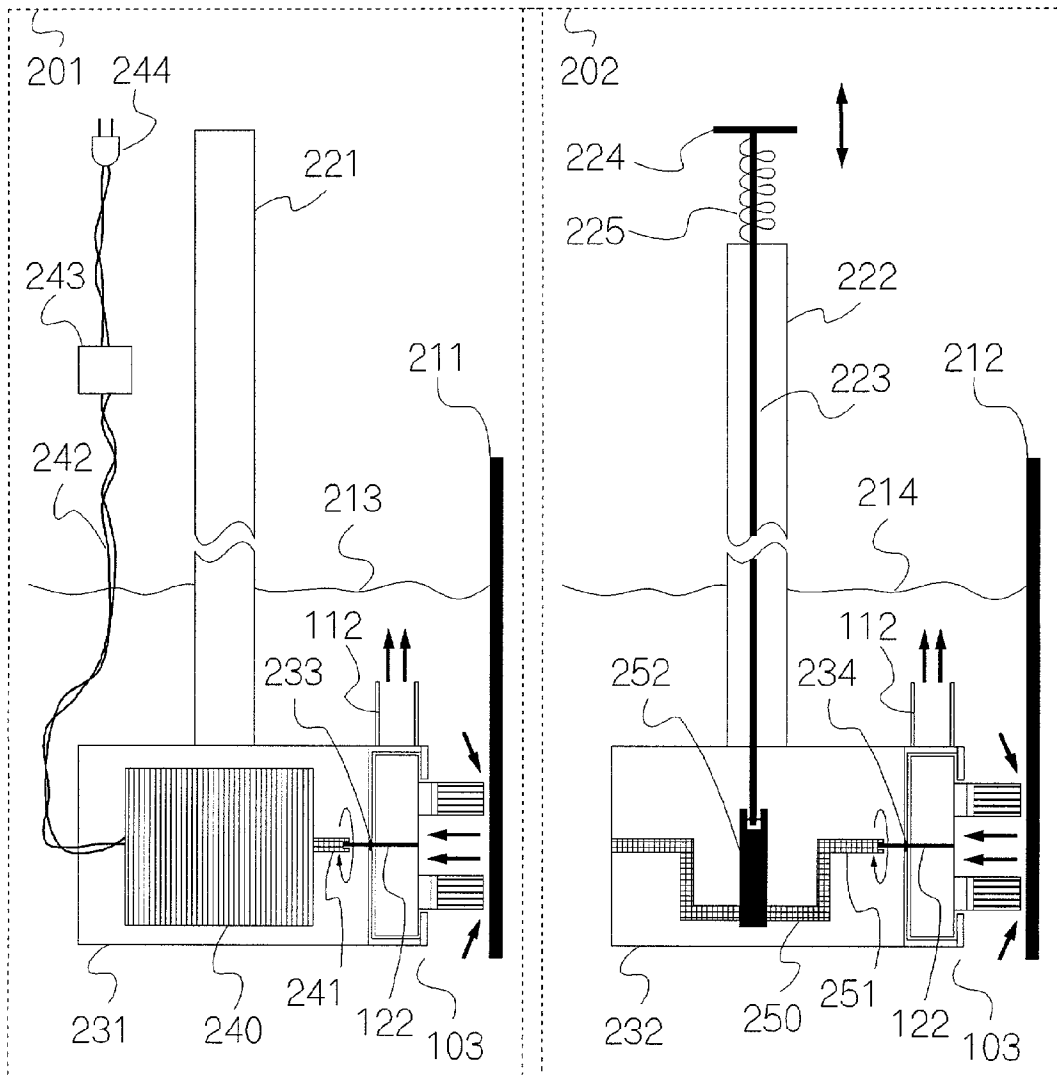

FIG. 2

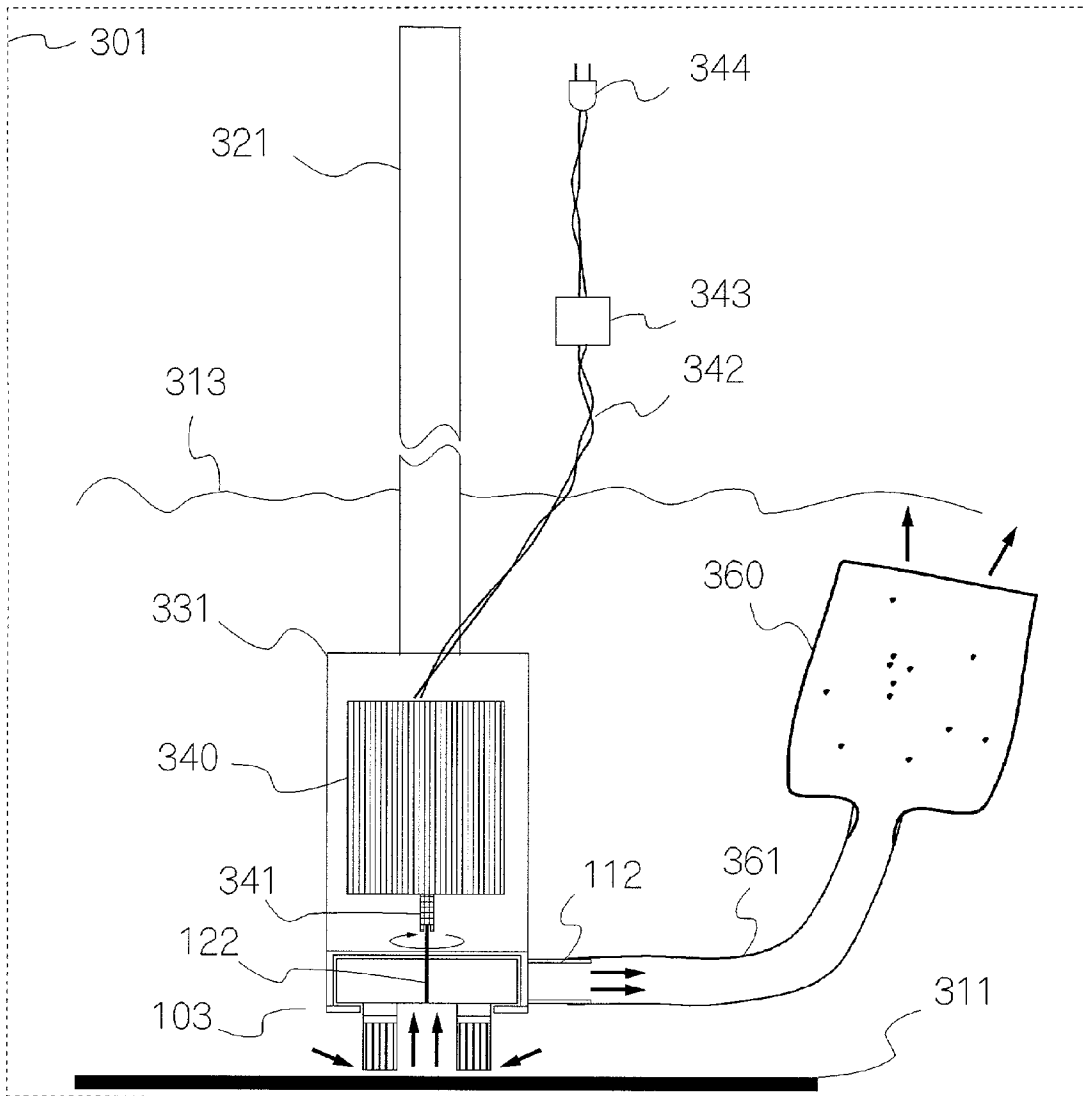

FIG. 3

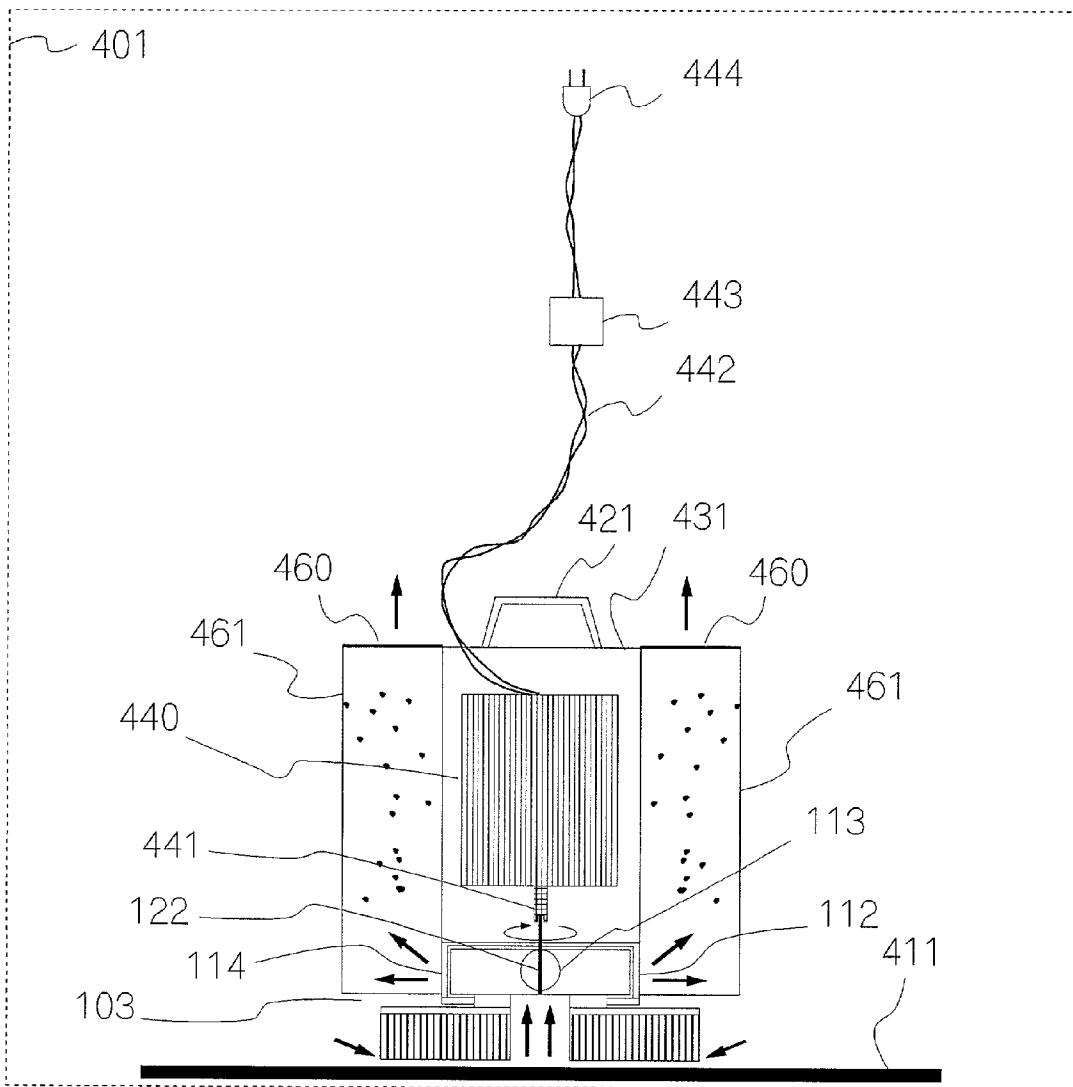

FIG. 4

METHOD AND APPARATUS OF OBTAINING SUCTION CONTROL OVER SURFACE CLEANING AND SCRAPING

FEDERALLY SPONSORED RESEARCH

[0001] (Not Applicable)

SEQUENCE LISTING OR PROGRAM

[0002] (Not Applicable)

BACKGROUND

[0003] 1. Field of Invention

[0004] This invention is directed to a method and two apparatuses obtaining suction control over surface cleaning and scraping. In other words suction control is provided with a cleaning/scraping pad allowing the pad to stick to the surface of an object to be cleaned/scraped thereby ensuring the effectiveness in cleaning/scraping. The scraped debris or dirt may be collected and removed after the cleaning/scraping process is completed.

[0005] 2. Prior Art

[0006] In cleaning/scraping the surface of a container, a building, or a piece of glass, say, a cleaning/scraping pad is used by the prior art rubbing against the surface to remove the unwanted dirt, contaminants, stains, or pollutants there. This rubbing action may be automated by using an electric motor. However, the contact between the cleaning/scraping pad and the surface to be cleaned remains otherwise arbitrary, and the cleaning/scraping pad needs to be pushed with force usually provided by hands pressing firmly against the wall so as to develop good contact there. For removing adhesive contaminants bound tightly to the surface cleaning/scraping of the surface can be an elaborated and tiresome job, since it may require extraordinary force to be exerted by hands over large areas, developing good contact between the cleaning/scraping pad and the surface so as to warrant effectiveness in cleaning/scraping. Furthermore, the prior art requires the movement of the cleaning/scraping pad to be manipulated manually. When cleaning/scraping over a large area, such as the outer surface of a big building, this can consume a lot of energy. A traction force is thus desired, automating the movement of a cleaning/scraping pad being sucked onto the surface of an object intended for cleaning/scraping.

[0007] Good contact between a cleaning/scraping pad and the surface of a wall in the environment of a liquid, water or oil, for example, is even harder to obtain, since the fluid will exert a buoyant force against the movement of the cleaning/scraping pad, resulting in possibly an inert laminar layer separating the cleaning/scraping pad and the surface of the wall. This makes the cleaning/scraping job much more difficult than as in air. Automated cleaning/scraping is almost impossible by the prior art if cleaning/scraping is intended involving a liquid. Thus, cleaning/scraping the wall of a fish tank or a swimming pool, for example, is normally carried out manually, and the cleaning/scraping pad is usually held by hands rubbing against the wall of the fish tank or the swimming pool with force, implying the nature of this kind of jobs to be tedious and painful.

[0008] In cleaning/scraping the surface of a wall in air or in a liquid the scraped dirt or debris are usually not

collected by the prior art. In preparing painting on a mortar wall or a dry wall, for example, the wall needs to be first scrapped with an abrasive pad to provide a smooth and flat surface. This generates tremendous ashes and dusts in air flying all over the room contaminating furniture nearby, rendering a process of nuisance and annoyance. Also, in cleaning, or brushing the gravels of a fish tank, the scrapped fish wastes and algae need to be collected and removed from the tank so as to maintain water quality. Again, this necessary step is lacking by the prior art.

OBJECTS AND ADVANTAGES

[0009] Accordingly, it is an object of the invention to address one or more of the foregoing disadvantages or drawbacks of the prior art, and to provide such an improved method and apparatuses to obtain suction control over the surface cleaning/scraping process involving an abrasive/brushing pad. This allows the pad to be bound to the surface firmly with the suction force to be adjustable depending on the cleaning/scraping conditions. Suction control may be applied in air or in a liquid, not only to provide effectiveness in surface cleaning/scraping, but also to achieve conveniences and hence to save efforts in performing such a job. The scraped debris or dirt may be collected and removed due to the suction action, thereby rendering a comfortable and healthy working environment.

[0010] Other objects will be apparent to one of ordinary skill, in light of the following disclosure, including the claims.

SUMMARY

[0011] In one aspect, the invention provides a method which sets up suction control along with the mechanical motion of a cleaning/scraping pad, allowing the pad to stick to the surface of an object to be cleaned/scraped. Suction action starts if air or a liquid is continuously removed or thrown out near the spot of the surface to be processed. By controlling the flow rate of air or the liquid, the suction force can be controlled, resulting in desirable contact of the pad in brushing or scraping the surface of the object. The scraped debris is able to be collected and removed due to this suction action accompanying the cleaning/scraping motion of the pad.

[0012] In another aspect, the invention discloses an apparatus which allows the suction action to be realized by using an automation machine, such as an electric motor. In operation the automation machine drives the cleaning/scraping pad to rub against a spot on the surface of an object to remove unwanted dirt, stains, or roughness there. Meanwhile, the automation machine continuously convects away the surrounding fluid near that spot on surface to create a suction force. As a consequence, the pad is pushed toward the surface of the object forming tight contact so as to render effectiveness in cleaning/scraping. The scraped debris or dirt may be collected and removed due to this induced suction action.

[0013] In another aspect, the invention discloses an apparatus which allows the suction action to be realized manually, via the use of a mechanical setup to be manipulated by hands. The mechanical setup involves cranks, gears, pulleys, and belts whatever necessary to manage a torque at an axle. To operate the mechanical setup generates a torque which

drives the cleaning/scraping pad to rub against a spot on the surface of an object to remove unwanted dirt, stains, or roughness there. Meanwhile, the generated torque also drives a paddle enabling the surrounding fluid near that spot on surface to be continuously convected away thereby creating a suction force. As a consequence, the pad is pushed toward the surface of the object forming tight contact so as to render effectiveness in cleaning/scraping. The scraped debris or dirt may be collected and removed due to this induced suction action.

DRAWINGS

[0014] Figures

[0015] For a more complete understanding of the nature and objectives of the present invention, reference is made to the following detailed description and accompanying drawings, which, though not to scale, illustrate the principles of the invention, and in which:

[0016] FIG. 1A shows one example of the preferred embodiment of the invention that a Cleaner/Scrapper Head is constructed consisting of 4 parts: Base/Side Assembly, Propeller, Cover, and Abrasive/Brush Pad Assembly. Top View and Side View of the Cleaner/Scrapper Head are also provided.

[0017] FIG. 1B shows more detail in the Abrasive/Brush Pad Assembly shown in FIG. 1A where a brush pad and a grinding pad may be distinguished; grooves may be carved on the surface of a grinding pad to facilitate convection of fluid flow on grinding a surface.

[0018] FIG. 2 shows two examples of the preferred embodiment of the invention that Cleaner/Scrapper Heads disclosed in FIG. 1A are used to construct Cleaning/Scraping Tools capable of scraping/brushing away stains or dirt appearing on the surface of a vertical wall immersed in water: one uses an electric motor, and the other uses a manual crank tool. Although demonstrated in water environment, the same apparatuses can be equally applied in air.

[0019] FIG. 3 shows another example of the preferred embodiment of the invention that a Cleaner/Scrapper Head disclosed in FIG. 1A is used to construct a cleaning/scraping tool capable of scraping/brushing away stains or dirt appearing on the surface of a horizontal wall immersed in water. A filter bag is included with the Cleaner/Scrapper Head so that the scraped debris can be collected, subject to subsequent removal. Although demonstrated in water environment, the same setup can be equally applied in air.

[0020] FIG. 4 shows another example of the preferred embodiment of the invention that a Cleaner/Scrapper Head disclosed in FIG. 1A is used to construct a cleaning/scraping tool capable of scraping/brushing away stains or dirt appearing on the surface of a horizontal wall in air. Filter bag and the dust chamber have been integrated with the cleaning/scraping tool to achieve a compact size, and hence convenience in use. For cleaning purposes FIG. 4 shows an apparatus that combines a broom and a vacuum cleaner in one device.

REFERENCE NUMERALS

[0021]

Reference Numerals	
101	Disassembled Parts of Cleaner/Scrapper Head
102	Top View of Cleaner/Scrapper Head
103	Side View of Cleaner/Scrapper Head
110	Base/Side Assembly of Cleaner/Scrapper Head
120	Propeller of Cleaner/Scrapper Head
130	Cover of Cleaner/Scrapper Head
140, 143	Abrasive/Brush Pad Assembly of Cleaner/Scrapper Head
111	Base/Side
112, 113, 114	Pipe Outlet
113	Through Hole
121	Paddle Arms
122	Cleaner/Scrapper Axle
123	Pedestal Plate
141	Base Plate
142	Abrasive/Brush Pad
144	Grinding Plate
145, 146, 147, 148	Grooves
201	Side View of Automatic Cleaning/Scraping Tool at Operation in Water
202	Side View of Manual Cleaning/Scraping Tool at Operation
211, 212	Vertical Wall Immersed in Water to be Cleaned/Scraped
213, 214	Water Surface
221	Cleaner/Scrapper Handler
222	Cleaner/Scrapper Handler (Hollow Cylinder)
223	Crank Shaft Rod
224	Spring Stopper/Shaft-End Knob
225	Crank Spring
231	Motor Housing
232	Crank Housing
233, 234	O-Ring
240	Electric Motor
241	Motor Axle
242	Wire Cable
243	Motor Controller
244	Power Plug
250	Crank
251	Crank Axle
252	Crank Joint
301	Side View of Automatic Cleaning/Scraping Tool at Operation in Water
311	Horizontal Wall/Gravels Immersed in Water to be Cleaned/scraped
313	Water Surface
321	Cleaner/Scrapper Handler
331	Motor Housing
340	Electric Motor
341	Motor Axle
342	Wire Cable
343	Motor Controller
344	Power Plug
360	Filter Bag
361	Water Tube
401	Side View of Automatic Cleaning/Scraping Tool at Operation in Air
411	Horizontal Wall in Air
421	Cleaner/Scrapper Handler
431	Motor Housing
440	Electric Motor
441	Motor Axle
442	Wire Cable
443	Motor Controller
444	Power Plug
460	Filter Wall
461	Dust Chamber

DETAILED DESCRIPTION

[0022] Preferred Embodiment:—FIG. 1A and FIG. 1B

[0023] FIG. 1A shows an example of the preferred embodiment of the invention that a Cleaner/Scrapper Head, 101, is constructed in terms of 4 parts: Base/Side Assembly 110, Propeller 120, Cover 130, and Abrasive/Brush Pad Assembly 140. Top View and Side View of Cleaner/Scrapper Head 101 are also included with FIG. 1A, shown as 102 and 103, respectively. The first part of Cleaner/Scrapper Head 101 is Base/Side Assembly 110, which includes Base/Side 111 with Pipe Outlet 112 opened at Side. A through hole 113 is included with Base located at center.

[0024] The second part of Cleaner/Scrapper Head 101 is Propeller 120, including two perpendicular Paddle Arms 121 intersected at their respective centers. Cleaner/Scrapper Axle 122 extends out from the center of Paddle Arms 121, and a ring-shaped Pedestal Plate 123 is attached to the back of Paddle Arms 121 showing a circular symmetry. Propeller 120 is placed inside Base/Side Assembly 110 with Cleaner/Scrapper Axle 122 of Propeller 120 inserted through Hole 113 located at Base center of Base/Side 111. Cover 130 of Cleaner/Scrapper Head 101, which forms the third part, is then placed on top of Base/Side 111, enclosing Propeller 120 inside Cleaner/Scrapper Head 101. Cover 130 assumes a ring geometry, whose outer diameter equals that of Base/Side 111, and inner diameter to be slightly larger than the outer diameter of Pedestal 123. As such, Pedestal 123 protrudes out from Cover 130, capable of performing rotational motion conveyed through Cleaner/Scrapper Axle 122.

[0025] Abrasive/Brush Pad Assembly 140, which forms the fourth part of Cleaner/Scrapper Head 101, is then mounted on top of Pedestal 123 installed with Propeller 120. That is, Base Plate 141 of Abrasive/Brush Pad Assembly 140 has the same inner diameter as Pedestal Plate 123, which may be attached to Pedestal Plate 123 either permanently or in a detachable manner. Although the outer diameter of Base Plate 141 is shown equal to the outer diameter of Pedestal Plate 123, it is not necessary. Depending on the requirement in cleaning/scraping and in suction the outer diameter of Base Plate 141 can be larger or smaller than the outer diameter of Pedestal Plate 123, providing more or less cleaning/scraping force than the suction force, respectively.

[0026] Abrasive/Brush Pad 142 resides on top of Base Plate 141 performing cleaning/scraping action of Cleaner/Scrapper Head 101. After assembling, Top View and Side View of Cleaner/Scrapper Head 101 are shown in FIG. 1A as 102 and 103, respectively. Thus, via applying a torque at Cleaner/Scrapper Axle 122, Paddle Arms 121, as well as Abrasive/Brush Pad 142, can then be set up to rotate. While the latter part provides the cleaning/scraping action, the former part serves as a pump, sucking in air or a liquid at the central portion of Cleaner/Scrapper Head 101, 102, or 103, conveying it toward periphery, then dispersed out at Pipe Outlet 112.

[0027] When Cleaner/Scrapper Head 101, 102, or 103 is brought close to the surface of an object, pumping of the fluid, say, air or a liquid, performed by Propeller 120 converts into suction action, provided that Abrasive/Brush Pad 142 shows a porous structure to be permeable to the fluid flow. This is generally true for a scrubbing pad or a brush pad. However, for a grinding pad made of sand paper,

for example, this condition is generally not true. For a grinding pad grooves need to be cut on the surface to allow the pad to be permeable to fluid flow. Both Brush Pad and Grinding Pad are shown in FIG. 1B, referred to as 140 and 143, respectively. For Grinding Pad 143 Grooves 145, 146, 147, 148 are cut on surface of Pad 144 residing on Base Plate 141. Without Grooves 145, 146, 147, 148 Grinding Pad 143 may be entirely sucked onto the surface of an object too tight to be movable.

[0028] The generated suction force pushes forward Cleaner/Scrapper Head 101, 102, or 103 to form tight enough contact with the surface of an object, enabling Abrasive/Brush Pad 142 in FIG. 1A to clean or scrape that surface with efficiency. This suction force can be adjusted by varying the rotational speed of Paddle Arms 121, and slower the motion of Paddle Arms 121 implies a lighter suction force, and vice versa. In FIG. 1A Paddle Arms 121 may assume other geometries, so long as air or the liquid is continuously removed or convected away from the local area of the surface subject to cleaning/scraping.

[0029] More than one Pipe outlets may appear surrounding the side of Base/Side 111 shown in FIG. 1A. A 90° elbow may be used connecting Pipe Outlet 112 so that air or the liquid is ejected or thrown away toward the backward direction. As such, the counteraction force due to ejection or throwing reinforces the suction action of pumping. Alternatively, Pipe Outlet 112 shown in FIG. 1A has the advantage of providing a traction force for guiding the movement of Cleaner/Scrapper Head 101, 102, or 103. Ejecting or throwing air or the liquid along one horizontal direction implies a traction force along the opposite direction. In performing heavy-duty cleaning/scraping a large suction force is desired, which also means a large inertia for Cleaner/Scrapper Head 101, 102, or 103 to move. In this case a traction force is needed, facilitating the movement of Cleaner/Scrapper Head 101, 102, or 103, alleviating the labor required for cleaning/scraping, especially when cleaning/scraping is required over a large surface area. Multiple Pipe Outlets each equipped with individual valve control are thought advantageous for the operation of a complex Cleaner/Scrapper Head apparatus providing sophisticated and efficient scraping/suction/traction controls at operation, especially when used over a large surface area requiring heavy-duty operation. Debris resulted from the cleaning or scraping process can be collected by connecting a filter bag at Pipe Outlet 112, as discussed with FIG. 3 below.

[0030] Preferred Embodiment:—FIG. 2

[0031] FIG. 2 shows two configurations that cleaning/scraping tools are constructed using same Cleaner/Scrapper Head 103 shown in FIG. 1A. Cleaning/Scraping Tool 201 uses an automation machine such as an Electric Motor 240 to drive Cleaner/Scrapper Axle 122 of Cleaner/Scrapper Head 103, whereas a manual device of Crank 250 is illustrated with Cleaning/Scraping Tool 202. In Comparison with FIG. 1A, in FIG. 2 Cleaner/Scrapper Head 103 has been rotated 90° upward for ease of demonstration. Motor Axle 241 and Crank Axle 251 are connected to Cleaner/Scrapper Axle 122 of Cleaner/Scrapper Head 103 for Cleaning/Scraping Tool 201 and Cleaning/Scraping Tool 202, respectively. For Cleaning/Scraping Tool 201 Electric Motor 240 is enclosed in Motor Housing 231, AC powered through Power Plug 244 connected to Wire Cable 242. Motor Controller 243 is

inserted with Power Cable 242, capable of, for example, turning on and off the power line on one hand, and adjusting the rotational speed of Electric Motor 240 on the other hand. As a consequence, the pumping/scraping action, and hence the suction action of Cleaner/Scraper Head 103 can thus be controlled. In FIG. 2 although AC power is illustrated with Cleaning/Scraping Tool 201, DC power can equally be used, and Electric Motor 240 can be either an AC-type motor or a DC-type motor. Cleaner/Scraper Handler 221 is connected to Motor Housing 231, providing support for Cleaning/Scraping Tool 201. Cleaner/Scraper Handler 221 may be rotated relative to the axial direction of Electric Motor 240 so that the cleaning/scraping action of Cleaner/scraper Head 103 can be varied at different orientations relative to the direction of Cleaner/Scraper Handler 221. FIG. 3 below shows such a variation. Gear assembly may be inserted between Motor Axle 241 and Cleaner/Scraper Axle 122 of Cleaner/Scraper Head 103 to facilitate rotational speed adjustment.

[0032] In FIG. 2 Cleaning/Scraping Tool 202 is manipulated manually, and Crank 250 is used to convert the up-and-down motion of Crank Shaft Rod 223 into rotational motion of Crank Axle 251. By coupling Crank Axle 251 to Cleaner/Scraper Axle 122, the cranking action of Crank 250 in turn drives Cleaner/Scraper Head 103 to perform cleaning/scraping and suction actions. Crank Joint 252 is inserted between Crank Shaft Rod 223 and Crank 250 contained in Crank Housing 232. Cleaner/Scraper Handler 222 connects to Crank Housing 232 to provide support for Cleaning/Scraping Tool 202. Crank Handler 222 shows the geometry of a hollow cylinder to contain Crank Shaft Rod 223 at center. Crank Spring 225 is inserted between Spring Stopper/Shaft-End Knob 224 and the end of Cleaner/Scraper Handler 222, as shown in FIG. 2. To operate one may grasp Cleaner/Scraper Handler 222 using four fingers of one hand with the other finger, say, the thumb, pressing and then releasing Spring Stopper/Shaft-End Knob 224 repetitively. Or, one may grasp Cleaner/Scraper Handler 222 using one hand and press and then release Spring Stopper/Shaft End 224 repetitively using the other hand. In both manners Crank Shaft Rod 223 is set forth to perform up-and-down motion, thereof drives Crank Axle to perform rotational motion via the coupling of Crank 250. Gear assembly may be inserted between Crank Axle 251 and Cleaner/Scraper Axle 122 of Cleaner/Scraper Head 103 so as to tune the rotational speed and hence the scraping/pumping efficiency of Cleaning/Scraping Tool 202. Alternatively, gear assembly, or other mechanical means, including pulleys, belts, etc., is required to change the coupling orientation of Crank Axle 251 relative to the direction of Crank Shaft Rod 223, if they do not run perpendicular to each other as shown with Cleaning/Scraping Tool 202 in FIG. 2.

[0033] In FIG. 2 both Cleaning/Scraping Tools 201 and 202 are illustrated to operate in water environment, occurring in a container such as a fish tank or a swimming pool, for example. Container Walls to be cleaned/scraped are shown as 211 and 212 and Water surfaces 213 and 214 are demonstrated for Cleaning/Scraping Tools 201 and 202, respectively. In order to seal tight Motor Housing 231 and Crank Housing 232 against water leak, O-Ring 233 and O-Ring 234 are used respectively at their respective outlets confronting Cleaner/Scraper Head 103.

[0034] Along with the cleaning/scraping action of Cleaning/Scraping Tools 201 and 202 water flow directions are also illustrated in FIG. 2, indicating how the suction action provided by Cleaner/Scraper Head 103 to occur. That is, because water is continuously pumped out from the spot at the surface of Container Wall 211 and 212, negative pressure results thereof, causing Cleaner/Scraper Head 103 to be sucked toward Container Wall 211 and 212, thereby facilitating the intended cleaning/scraping action. In FIG. 2 water is ejected in the upward direction, giving rise to a traction force exerted on Cleaner/Scraper Head 103 in the downward direction. Traction force for Cleaning/Scraping Tools 201 and 202 is desirable, since Cleaner/Scraper Head 103 may be tightly sucked onto Container Wall 211 and 212, performing sufficient cleaning/scraping action there. In the absence of a traction force the movement of Cleaner/Scraper Head 103 might then be sluggish. Alternatively, 90° elbows may be equipped with Pipe Outlet 112, if the suction action of Cleaner/Scraper Head 103 does not cause a problem. By throwing water in the backward direction, further push of Cleaner/Scraper Head 103 toward Container Wall 211 and 212 is realized, reinforcing the generated suction force there according to Newton's third law.

[0035] Although Cleaning/Scraping Tools 201 and 202 are illustrated in FIG. 2 in water environment for the purpose of cleaning/scraping, they do not have to be limited to be so. Actually, the same Cleaning/Scraping Tools 201 and 202 can be used in air, performing cleaning, abrading, or grinding actions onto a dry-wall or a mortar-wall surface, for example. More Pipe Outlets 112 may be installed with Cleaner/Scraper Head 113, and a balance between the resultant suction force and the traction force exerted on Cleaner/Scraper Head 113 can thereof be optimized. This is done via considering the porosity of Abrasive/Brush Pad 142 shown in FIG. 1A, as well as the required speed of Propeller 120 in performing the cleaning/scraping action, as discussed in association with FIG. 1B.

[0036] Preferred Embodiment:—FIG. 3

[0037] FIG. 3 shows another configuration that Cleaning/Scraping Tool 301 is constructed using, again, the same Cleaner/Scraper Head 103 shown in FIG. 1A. Similar to Cleaning/Scraping Tool 201 shown in FIG. 2, Cleaning/Scraping Tool 301 shown in FIG. 3 uses an automation machine such as an Electric Motor 340 to drive Cleaner/Scraper Axle 122 of Cleaner/Scraper Head 103. Motor Axle 341 is connected to Cleaner/Scraper Axle 122 of Cleaner/Scraper Head 103. Electric Motor 340 is enclosed in Motor Housing 331, AC powered through Power Plug 344 connected to Wire Cable 342. Motor Controller 343 is inserted with Power Cable 342, capable of, for example, turning on and off the power line on one hand, and adjusting the rotational speed of Electric Motor 340 on the other hand. As a consequence, the pumping/cleaning, and hence the suction, action provided by Cleaner/Scraper Head 103 can thus be controlled. In FIG. 3 although AC power is illustrated there, DC power can equally be used, and Electric Motor 340 can be either an AC-type motor or a DC-type motor. Cleaner/Scraper Handler 321 is connected to Motor Housing 331, providing support for Cleaning/Scraping Tool 301. In contrast to Cleaning/Scraping Tool 201 shown in FIG. 2 Cleaner/Scraper Handler 321 in Cleaning/Scraping Tool 301 runs parallel to the axial direction of Electric Motor 340, intended for cleaning/scraping the bottom surface of Con-

tainer Wall 311 in water environment. In a fish tank gravels may appear at the bottom surface, and Cleaning/Scraping Tool 301 can be used to clean, or more precisely, to brush, the gravels. Water Surface is shown in FIG. 3 as 313.

[0038] The other difference shown with Cleaning/Scraping Tool 301 in FIG. 3 is the addition of Filter Bag 360 connected to Pipe Outlet 112 of Cleaner/Scrapper Head 103 via Water Tube 361. Along with the cleaning/scraping action of Cleaner/Scrapper Head 103, water is continuously pumped out from a spot on Container Wall 311 to be cleaned/scraped, ejected from Pipe Outlet 112, passing through Water Tube 361, entering Filter Bag 360. Water flow directions are illustrated in FIG. 3. Filter Bag 360 is permeable only to water flow, but not to debris or dirt left off due to the cleaning/scraping action performed at the surface of Container Wall 311. Therefore, debris and dirt are separated from water, to be kept in Filter Bag 360 subject to subsequent removal. In this manner, not only container wall of a fish tank can be cleaned/scraped, for example, but also the surfaces of gravels, rocks, and decorations whatever immersed under water contained by a fish tank, thereof making it possible for convenient maintenance in water quality. Feeding and watching a tropical fish is of a great fun. However, cleaning and scraping a fish tank thereby maintaining water quality is of a great pain, especially to those people who hate to get their hands wet. By using Cleaning/Scraping Tool 301 shown in FIG. 3 cleaning/scraping a fish tank is no longer painful, allowing automation to result with effectiveness without requiring hands to be dipped in water. A manual tool similar to Cleaning/Scraping Tool 202 shown in FIG. 2 intended for fish-tank maintenance can also be constructed.

[0039] Cleaning/Scraping Tool 301 shown in FIG. 3 can also be used in air not necessarily to assume water environment. For example, before painting a drywall or a mortar wall, the surface needs to be grinded first so as to make it clean, smooth, and flat. In grinding the surface of a drywall or a mortar wall, however, ashes and dusts are inevitably generated, creating a nasty environment at work. By using Cleaning/Scraping Tool 301 shown in FIG. 3 scraping a mortar surface, say, is no longer an offensive process, since ashes and dusts are all collected in Filter Bag 360 before they could otherwise be set out to fly in a house. Other discussions appearing with FIG. 1A, FIG. 1B, and FIG. 2 can equally apply for Cleaning/Scraping Tool 301 shown in FIG. 3.

[0040] Preferred Embodiment:—FIG. 4

[0041] FIG. 4 shows another configuration that Cleaning/Scraping Tool 401 is constructed using, again, the same Cleaner/Scrapper Head 103 shown in FIG. 1A. Similar to Cleaning/Scraping Tool 301 shown in FIG. 3, Cleaning/Scraping Tool 401 shown in FIG. 4 uses an automation machine such as an Electric Motor 440 to drive Cleaner/Scrapper Axle 122 of Cleaner/Scrapper Head 103. Motor Axle 441 is connected to Cleaner/Scrapper Axle 122 of Cleaner/Scrapper Head 103. Electric Motor 440 is enclosed in Motor Housing 431, AC powered through Power Plug 444 connected to Wire Cable 442. Motor Controller 443 is inserted with Power Cable 442, capable of, for example, turning on and off the power line on one hand, and adjusting the rotational speed of Electric Motor 440 on the other hand. As a consequence, the pumping/cleaning, and hence the suc-

tion, action provided by Cleaner/Scrapper Head 103 can thus be controlled. In FIG. 4 although AC power is illustrated, DC power can equally be used, and Electric Motor 440 can be either an AC-type or a DC-type motor. Cleaner/Scrapper Handler 421 is attached to Motor Housing 431, providing convenient handling of Cleaning/Scraping Tool 401. In contrast to Cleaning/Scraping Tool 301 shown in FIG. 3 Cleaning/Scraping Tool 401 shown in FIG. 4 is illustrated for use in air, and a Horizon Wall 411 is referred. Of course the same Cleaning/Scraping Tool 401 shown in FIG. 4 can apply to a vertical wall, and it can be used in water environment.

[0042] The other difference shown with Cleaning/Scraping Tool 401 in FIG. 4 is the integration of Water Tube 361 and Filter Bag 360 in FIG. 3 with Cleaning/Scraping Tool 301 to form a compact unit, becoming Dust Chamber 461 and Filter Wall 460 in FIG. 4, respectively. That is, in FIG. 4 Dust Chamber 461 assumes a cylindrical geometry surrounding Motor Housing 431 with Filter Wall 460 covered from top, allowing air, but not dusts to exit. Bottom of Dust Chamber 461 is otherwise sealed. In FIG. 4 four Pipe Outlets are included, referred to as 112 at left, 113 at front, 114, at right, and 115 at back. The Pipe Outlet 115 at back is not seen in FIG. 4. In order to accommodate the geometry of Dust Chamber 461 Pipe Outlets 112, 113, 114 and 115 possess zero length, exhibiting opening holes serving as air/dust entrances. This allows Dust Chamber 461 to be easily removed from the unit, for example, when it is time to dump the collected dusts or garbage. Air flow directions are also shown in FIG. 4. In accompanying the cleaning/scraping motion of Cleaner/Scrapper Head 103, air mixed with dusts or debris stripped off from the surface of Wall 411 is sucked into Dust Chamber 461 through the four hole openings at Outlets 112, 113, 114, and 115. While air is allowed to pass across Filter Wall 460, dusts are kept in Chamber 461 until it is removed from the unit to be emptied. The induced suction force also help making good contact between Cleaner/Scrapper Head 103 with the surface of Wall 411 so as to facilitate the intended cleaning/scraping process there, as discussed previously.

[0043] One minor difference shown in FIG. 4 includes the dimension change of Abrasive/Brush Pad Assembly 140 of Cleaner/Scrapper Head 103 shown in FIG. 1A. In FIG. 4 Cleaning/Scraping Tool 401 assumes a larger outer diameter for Abrasive/Brush Pad Assembly 140 than depicted in FIG. 1A. This implies a relatively stronger cleaning/scraping force and a relatively weaker suction force, as compared with those shown in FIG. 2, Cleaning/Scraping Tool 201, 202, and that in FIG. 3, Cleaning/Scraping Tool 301. Cleaning/Scraping Tool 401 shown in FIG. 4 may be used as a carpentry tool capable of grinding/sanding a wooden surface without generating much dusts. For this application a grinding pad is assumed, as discussed with Abrasive/Brush Pad 143 shown in FIG. 1B. Alternatively, it serves as a powerful cleaning tool capable of removing garbage or dirt in a nasty environment, including the worst situations where dusts are mixed with water and/or oil. That is, when a brush pad is equipped with Cleaner/Scrapper Head 103 shown in FIG. 1A, Cleaning/Scraping Tool 401 shown in FIG. 4 provides dual operations of a broom and a vacuum cleaner. While the cleaning/scraping action provided by Cleaner/Scrapper Head 103 serves as a broom, the suction action generated by Paddle 120 shown in FIG. 1A behaves exactly like a vacuum cleaner. The combination of two cleaning/

scraping devices in one can no doubt amplify their respective functions. Other discussions appearing with **FIG. 1A**, **FIG. 1B**, **FIG. 2**, and **FIG. 3** can equally apply for Cleaning/Scraping Tool **401** shown in **FIG. 4**.

[0044] Conclusions

[0045] Cleaning/Scraping Tools **201**, **202** shown in **FIG. 2** and **301** shown in **FIG. 3** can be applied under general conditions in air and/or in water environments. An effective cleaning/scraping pad can thus be realized rubbing against a contaminated wall or a rough wall providing efficiency, since the pad is allowed to suck toward the wall insuring good contact for the rubbing action. Traction force on the pad is also possible, navigating the movement of the pad across the surface to be cleaned or scraped. This facilitates cleaning or scraping over a large surface area. Furthermore, the suction action allows the dusts or dirt scraped off from the surface to be collected, thereby achieving desirable conditions in cleaning/scraping. This invention is most favorable in the following areas, although other applications may also be readily found:

- [0046]** dual vacuum cleaner/broom tool
- [0047]** cleaning/scraping a swimming pool
- [0048]** cleaning/maintaining a fish tank
- [0049]** abrading/preparing the surface of a mortar wall/dry wall
- [0050]** preparing/polishing wooden surfaces
- [0051]** cleaning/scraping the outside surface of big building
- [0052]** cleaning/scraping seashore rocks contaminated with oil
- [0053]** cleaning/Maintaining an oil tank

We claim:

1. A method of obtaining suction control over surface cleaning and scraping, comprising:

- A) setting up mechanical motion of a pad of a predetermined type sufficient to clean or scrape a spot on a surface,
- B) setting up pumping action accompanying said mechanical motion of said pad of said predetermined type capable of convecting away surrounding fluid from a region local to said pad,

wherein by moving said pad of said predetermined type close to said spot on said surface intended to be cleaned or scraped, said pumping action results in a negative pressure near said spot on said surface, giving rise to a suction force pushing said pad toward said spot on said surface to form tight contact, thereby facilitating the process of cleaning or scraping said surface on said spot.

2. The method of claim 1 wherein said surrounding fluid includes air, water, oil, or a mixture.

3. The method of claim 1 wherein said predetermined type of said pad includes, abrasive pads, brush pads, pads with cutting edges, scrubbing pads, grinding pads, or a mixture, so long as they are permeable to the flow of said fluid.

4. The method of claim 1 wherein filter bag is used to collect said surrounding fluid convected away from said region local to said pad.

5. The method of claim 1 wherein said surrounding fluid convected away from said region local to said pad is ejected in a predetermined direction inducing a traction force guiding said pad to move on said surface intended to be cleaned or scraped along a direction opposite to said predetermined direction.

6. The method of claim 1 wherein said surrounding fluid convected away from said region local to said pad is ejected in the backward direction normal to said surface intended to be cleaned or scraped thereby reinforcing said suction force pushing said pad toward said spot on said surface to form an even tighter contact.

7. The method of claim 1 wherein said surrounding fluid convected away from said region local to said pad is managed via valve controls so as to manipulate the ejection direction and amount of said fluid.

8. A surface cleaning/scraping tool device capable of executing cleaning/scraping action on a surface, comprising:

- (A) a pad of a predetermined type sufficient to rub or brush against said surface,
- (B) a paddle network of a predetermined geometry sufficient to remove the surrounding fluid in the region local to said pad,
- (C) an electric motor, being either an AC or a DC type, capable of inducing mechanical motion on said pad rubbing or brushing against said surface, and on said paddle network convecting away said surrounding fluid in said region local to said pad,

wherein, by controlling the speed of said electric motor, not only said mechanical motion of said pad is under control, giving rise to a friction force of a desired magnitude exerted by said pad rubbing against said surface, but also said peddle network generates a suction force also of a desired magnitude, pushing said pad onto said surface forming tight contact thereby facilitating the execution of said cleaning/scraping action.

9. The surface cleaning/scraping tool device of claim 8 wherein said surrounding fluid includes air, water, oil, or a mixture.

10. The surface cleaning/scraping tool device of claim 8 wherein said predetermined type of said pad includes, abrasive pads, brush pads, pads with cutting edges, scrubbing pads, grinding pads, or a mixture, so long as they are permeable to the flow of said fluid.

11. The surface cleaning/scraping tool device of claim 8 wherein filter bag is used to collect said surrounding fluid convected away from said region local to said pad.

12. The surface cleaning/scraping tool device of claim 8 wherein said surrounding fluid convected away from said region local to said pad is ejected in a predetermined direction inducing a traction force guiding said pad to move on said surface intended to be cleaned or scraped along a direction opposite to said predetermined direction.

13. The surface cleaning/scraping tool device of claim 8 wherein said surrounding fluid convected away from said region local to said pad is ejected in the backward direction normal to said surface intended to be cleaned or scraped thereby reinforcing said suction force pushing said pad toward said surface to form an even tighter contact.

14. A surface cleaning/scraping tool device capable of executing cleaning/scraping action on a surface, comprising:

- (A) a pad of a predetermined type sufficient to rub or brush against said surface,
- (B) a paddle network of a predetermined geometry sufficient to remove the surrounding fluid in the region local to said pad,
- (C) a manual mechanical setup in the form of cranks, gears, pulleys, belts, springs, and so forth, manipulated by hands capable of inducing mechanical motion on said pad rubbing or brushing against said surface, and on said paddle network convecting away said surrounding fluid in said region local to said pad,

wherein, by controlling the speed in manipulating said manual mechanical setup, not only said mechanical motion of said pad is under control, giving rise to a friction force of a desired magnitude exerted by said pad rubbing against said surface, but also said peddle network generates a suction force also of a desired magnitude, pushing said pad onto said surface forming tight contact thereby facilitating the execution of said cleaning/scraping action.

15. The surface cleaning/scraping tool device of claim 14 wherein said surrounding fluid includes air, water, oil, or a mixture.

16. The surface cleaning/scraping tool device of claim 14 wherein said predetermined type of said pad includes, abrasive pads, brush pads, pads with cutting edges, scrubbing pads, grinding pads, or a mixture, so long as they are permeable to the flow of said fluid.

17. The surface cleaning/scraping tool device of claim 14 wherein filter bag is used to collect said surrounding fluid convected away from said region local to said pad.

18. The surface cleaning/scraping tool device of claim 14 wherein said surrounding fluid convected away from said region local to said pad is ejected in a predetermined direction inducing a traction force guiding said pad to move on said surface intended to be cleaned or scraped along a direction opposite to said predetermined direction.

19. The surface cleaning/scraping tool device of claim 14 wherein said surrounding fluid convected away from said region local to said pad is ejected in the backward direction normal to said surface intended to be cleaned or scraped thereby reinforcing said suction force pushing said pad toward said surface to form an even tighter contact.

* * * * *