

(No Model.)

2 Sheets—Sheet 1.

S. D. LOCKE, Jr.

SHEAF CARRIER AND DUMPER FOR HARVESTERS.

No. 524,991.

Patented Aug. 21, 1894.

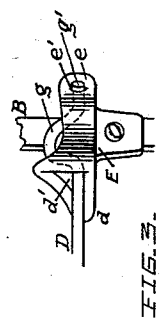
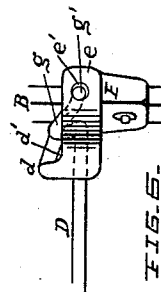
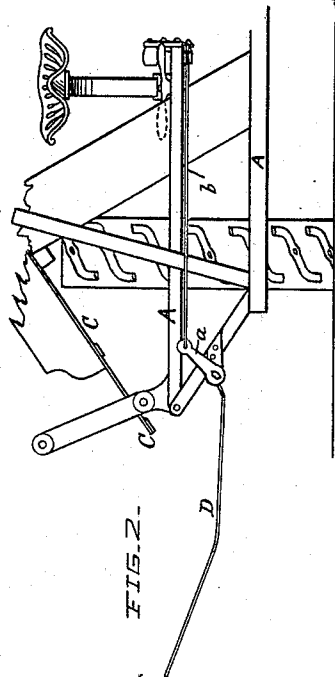
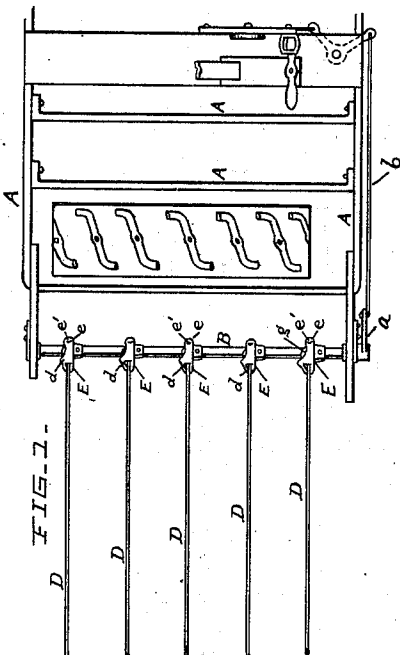
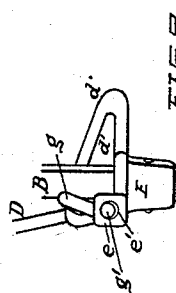
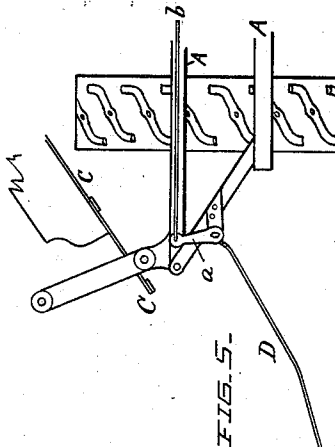
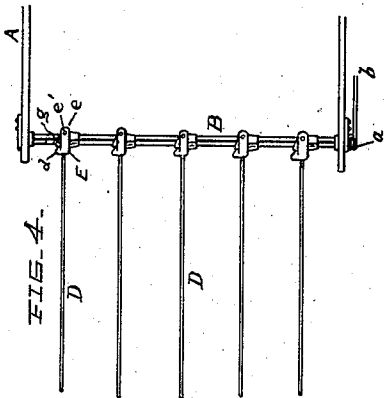
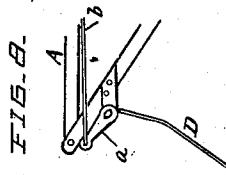
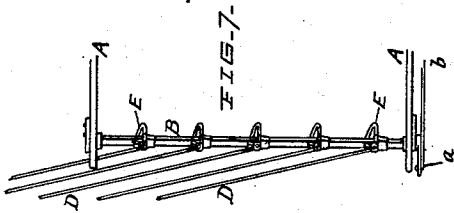

WITNESSES:

*Charles H. Platts*  
*S. D. Locke*

INVENTOR,

*Sylvanus D. Locke, Jr.*

(No Model.)

2 Sheets—Sheet 2.

S. D. LOCKE, Jr.

SHEAF CARRIER AND DUMPER FOR HARVESTERS.

No. 524,991.

Patented Aug. 21, 1894.

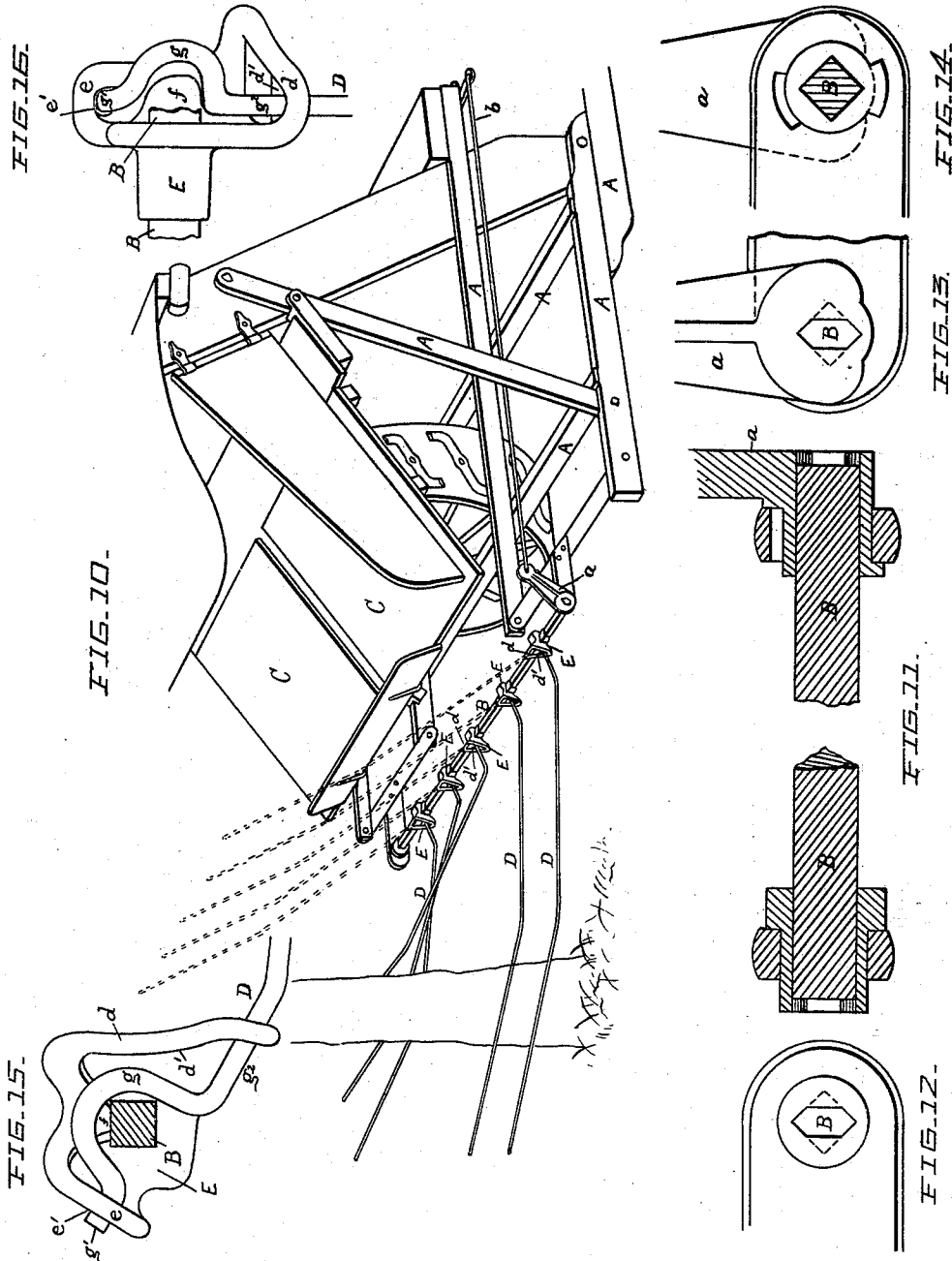

WITNESSES:

*Chas. H. Platts*  
*J. D. Locke*

INVENTOR,

*Sylvanus D. Locke, Jr.*

# UNITED STATES PATENT OFFICE.

SYLVANUS D. LOCKE, JR., OF HOOSICK FALLS, NEW YORK.

## SHEAF CARRIER AND DUMPER FOR HARVESTERS.

SPECIFICATION forming part of Letters Patent No. 524,991, dated August 21, 1894.

Application filed May 12, 1894. Serial No. 510,966. (No model.)

### *To all whom it may concern:*

Be it known that I, SYLVANUS D. LOCKE, Jr., a citizen of the United States, residing at Hoosick Falls, county of Rensselaer, and State of New York, have invented certain new and useful Improvements in Sheaf Carriers and Dumpers for Harvesters, of which the following is a specification.

This invention relates to that class of sheaf-carriers and dumpers in which the sheaf-delivering fingers are lowered and moved rearwardly toward the machine in delivering the sheaves, and has especial reference to such devices in which the fingers are mounted upon and operated by a rock shaft.

The object of this invention is to provide a machine by means of which the delivering fingers will individually and collectively be operated to deliver the sheaves and also to pass obstructions and automatically return to their normal position, and also to fold upward and backward against the end of the delivering table to narrow the machine for transportation from field to field or along the highway.

The invention consists in the construction and arrangement for this object of the various devices as hereinafter set forth and claimed.

Referring to the accompanying drawings, Figure 1 is a plan view of a part of the harvester showing the carrier in its normal position. Fig. 2 is a front view in elevation of the same. Fig. 3 is a plan view of an enlarged portion of the rock shaft, a finger support and finger in normal position. Fig. 4 is a plan view of the carrier in dumping position. Fig. 5 is a front view in elevation of the same. Fig. 6 is a detail plan view of an enlarged portion of one of the fingers, its support and the rock shaft in dumping position. Fig. 7 is a plan view of the carrier in its final discharging position. Fig. 8 is a front view in elevation of the same. Fig. 9 is a detail plan view of an enlarged portion of one of the fingers, its support and the rock shaft in the final discharging position shown in Fig. 7. Fig. 10 is a view in perspective of the invention illustrating the manner in which the fingers clear an obstruction. This figure also shows in dotted lines the fingers folded up and back for transportation. Fig. 11 is a

longitudinal, central section of the rock shaft and its bearings and operating crank. Fig. 12 is a rear end view of the rock shaft and its rear bearing. Fig. 13 is a front end view of the rock shaft, its crank and bearing. Fig. 14 is a cross section of the rock shaft and a rear view of its crank and front bearing. Fig. 15 is also a cross section of the rock shaft and a rear view of a finger support, as in position shown in Figs. 1, 2 and 3. Fig. 16 is an under side view of the same with the shaft cut away.

So much of a harvester as is necessary to illustrate this invention, is shown on the frame A, on which is mounted a rock shaft B, located beneath the binding or delivering table C, and operated by a crank arm *a*, rod *b* and the proper connections extending to the driver's seat.

D are the fingers which are mounted and rest at their inner ends in supports E secured to rock shaft B. The fingers may be bent upward as shown in Figs. 2, 5 and 10, to more readily hold the sheaves. In delivering the sheaves, the fingers are lowered from the horizontal or normal position, shown in Figs. 1 and 2, by means of the rock shaft B, operated by the driver.

In order that the fingers may be brought to a discharging position alongside of the machine, as shown in Figs. 7 and 8, and may automatically return to their normal position; and in order that they may individually and collectively automatically clear obstructions, as shown in Fig. 10; and, in order that the fingers may be also brought to a final upward folded carrying position for transportation from field to field or along a highway as shown by dotted lines in Fig. 10; the fingers and their supports are constructed and arranged as follows:

The supports E, bolted or otherwise secured to and extending about the rock shaft B, are formed with the rear projecting portion *e*, having the perforation *e'* in which is located and loosely mounted the rear end *g'*, of the finger D, so as to permit of a rolling and vibratory movement thereof and forming a universal joint.

*d* indicates a front enlarged portion of the support E, provided with the triangular opening *d'*, through which extends the finger D. This opening or slot is made wider at the top

than at the bottom to give the fingers more freedom of motion when dumping or clearing obstructions, that is, when rising from the bottom of the opening.

5 The portion of the support E, between the ends *d* and *e*, is curved outwardly so as to form a recess, chamber or socket between the support E and the rock shaft B, in which recess is located the curved or bowed portion *g* of the finger D, the curved portion *g* normally bearing against the rock shaft B, as shown in Figs. 3, 6 and 9, and preventing the fingers from rolling when in the normal position.

10 The straight portions *g'* and *g''* of the fingers D are at an angle to the main portion of the fingers, but are in line with each other, and in the same vertical plane with the finger when in a carrying position, and form the axes of rotation of the fingers. The plane of the bowed portion *g*, of the finger D is at an angle to the plane of the remainder of the finger. This makes the angle between the plane of *g* and that portion of the rock shaft upon which it slides always other than a right angle and obviates the necessity of interposing an inclined slideway between *g* and the rock shaft B.

15 By means of the foregoing construction and arrangement of parts, when the fingers have been lowered by the rotation of the rock shaft until their outer ends encounter the ground, the fingers will trail rearward, the portion resting in the triangular opening *d'* riding up on the rear side thereof and the curved portion *g* turning in the recess in support E away from the recess wall or stop *f*, and sliding on the rock shaft B causes the finger D to tilt upward, the fingers in this movement rolling on their longitudinal axis. Should the harvester be raised or lowered or tilted when the fingers are folded beneath the rock shaft, the width of the upper part of the opening *d'* will permit of enough vibratory movement of the fingers to prevent them from leaving the ground when machine is raised or being driven into it when machine is lowered. On rotating the rock shaft B back again to restore the fingers from the trailing tilted position to the normal position and when the ends of the fingers have been lifted from the ground, the weight of the fingers is thrown upon the bowed portion *g*, resting upon the rock shaft B, so that in falling to the bottom of the opening *d'*, the fingers are again rotated to their upright normal positions. The bowed portion *g*, during its rotation, slides upon the rock shaft B until it strikes the recess wall or stop *f*. This sliding is insured by the portion *g* of the finger D being bent at an angle to the plane of the main part of the finger, as described.

20 It will readily be seen also that this construction and arrangement of the fingers and their connections are also advantageous in that the fingers individually and collectively will easily and effectively clear any obstruction, however high as a stump or tree shown

in Fig. 10, each finger being pushed back by the obstruction and yielding rearwardly and upwardly to ride over the obstruction and then rolling and falling back automatically to the normal position. In handling the sheaves the fingers act in unison, the rotation of the rock shaft contributing to their movement, while in encountering obstructions the fingers act individually and without operating the rock shaft to ride over the obstruction and to fall by gravity back to their normal position.

25 Another advantage of this invention is that should a sheaf be dropped on the fingers before they had entirely reached their horizontal position, the movement of the fingers would be accelerated thereby, and should a sheaf be discharged on to the fingers while they were clearing an obstruction, the sheaf would not escape from the fingers. It is also apparent from the described connection and arrangement of the fingers and finger supports and their connections, which has been demonstrated practically in a full sized machine, that if, when in the normal position shown in Fig. 1, the fingers be raised by the operator, at the same time slightly rotating the rock shaft, they will fall backwardly and rearwardly as shown by dotted lines in Fig. 10, the centers of gravity of the fingers having passed within or beyond the rock shaft, into the rear upper angles of the triangular openings in the finger supports, or against the outer edge of the delivering table C, the concave sides of the teeth striking the table so that the ends are inside of the outer edge of the table, where they can be securely carried in the transportation of the harvester and binder from field to field or along the highway.

What I claim is—

1. In a grain harvester and binder, a sheaf carrier provided with universally hinged fingers movable from a horizontal position downwardly and rearwardly to discharge the load, and adapted to swing automatically upwardly and rearwardly on their hinges and to roll rearwardly on their longitudinal axes to pass stumps or other high obstructions.

2. In a grain harvester and binder, a sheaf carrier having a rock shaft and finger supports attached to the shaft, in combination with fingers universally hinged to said supports and movable from their normal position downwardly with the shaft and then to roll rearwardly to discharge their load, and adapted to swing on their hinges automatically upwardly and to rotate rearwardly on their longitudinal axes to pass stumps or other high obstructions.

3. In a grain harvester and binder, a sheaf carrier having a rock shaft and finger supports attached to the rock shaft, in combination with fingers universally hinged on the supports and movable downwardly and rearwardly from a horizontal position to discharge the load, and adapted, when the shaft is

raised, to swing upwardly on their hinges and to roll rearwardly on their longitudinal axes to fold by gravity beyond the rock shaft into the rear upper angles of the supports or against the outer edges of the delivering table.

4. In a grain harvester and binder, a sheaf carrier provided with a rock shaft and with rotary fingers universally jointed thereon and inclined guides over which the fingers ride, the fingers being movable downwardly from the horizontal position and then rearwardly and upwardly automatically movable to pass obstructions, and forwardly and downwardly to the horizontal position upon the raising of the rock shaft.

5. In a grain harvester and binder, a sheaf carrier having a rock shaft and guides inclined rearwardly upward thereon over which the fingers ride, in combination with fingers universally jointed on the rock shaft, and movable downwardly therewith and then rearwardly and upwardly automatically movable to discharge the load or to pass obstructions, and back to normal position upon raising the rock shaft.

6. In a grain harvester and binder, a sheaf carrier provided with a rock shaft, and chambered finger supports thereon, having inclined guides over which the fingers ride, in combination with rotary fingers having their ends universally jointed in the supports, and formed with curved portions located in the supports, the fingers being movable downwardly from the horizontal, and then automatically upwardly and rearwardly to discharge the load or to pass obstructions, and back to their normal position.

7. In a sheaf carrier, a finger having its inner end universally jointed to a rock shaft and formed with the bowed portion *g'* adjacent to its inner end to hold the finger horizontally in its receiving position and to rotate it when moving rearwardly to discharge or moving upwardly and rearwardly to pass obstructions or to fold for transportation.

8. In a sheaf carrier, a finger support secured to a rock shaft and formed with a recessed portion and a projection at either end of the recessed portion, at an angle thereto, one of said projections having an aperture for the rear end of the finger, and the other projection having a triangular opening serving as a guide and rest for the finger.

9. In a grain harvester and binder, a sheaf carrier provided with a rock shaft carrying finger supports having guides inclined rearwardly upward in combination with fingers universally jointed at their rear ends to the supports, and projecting horizontally over

the inclined guides, and adapted to ride vertically thereon, the inclined guides extending in a plane substantially vertical and coincident with the line of travel of the harvester.

10. In a grain harvester and binder, a sheaf carrier provided with a rock shaft, and finger supports thereon, the finger supports having portions with triangular openings depending from the rock shaft in a vertical plane substantially coincident with the line of travel of the harvester, in combination with fingers having their rear ends universally jointed to the supports, and projecting through the triangular openings thereof, and adapted to move vertically on the rear inclined portions of the triangular openings.

11. In a grain harvester and binder, a sheaf carrier provided with a rock shaft having finger supports each with an inclined guide depending from the rock shaft in a vertical plane, substantially coincident with the line of travel of the harvester, in combination with fingers universally jointed to the supports and projecting over and adapted to ride vertically on the inclined guides, the fingers being adapted to be moved upwardly and rearwardly from their normal horizontal position and to fall back thereto by gravity.

12. A sheaf carrier composed of a rocking bar, finger supports secured to the rocking bar, fingers individually and universally pivoted in orifices on one side of the rocking bar, and supported and guided by openings in the supports on the other side of the bar, and having the portion between the pivots and the supports arched over the bar and their outreaching portions at an angle to their pivots, as and for the purpose described.

13. A sheaf carrier composed of a rocking bar, finger supports secured to the rocking bar, fingers individually pivoted in orifices on one side of the rocking bar and supported and guided by openings in the supports on the other side of the bar and by recessed portions of the supports over the bar, the portion of the fingers between the pivot and the guides being arched over the bar, and having their outreaching portions at an angle to their pivots, whereby, as the bar is rocked, the fingers coming in contact with the ground are in overturning moved to the rear to trail beneath the machine.

In witness whereof I have hereunto set my hand this 10th day of May, 1894.

S. D. LOCKE, JR.

Witnesses:

S. D. LOCKE,  
JOHN WRIGHT.