



INTERNATIONAL APPLICATION PUBLISHED UNDER THE PATENT COOPERATION TREATY (PCT)

<p>(51) International Patent Classification ⁶ : A61B 7/04, H04R 1/10</p>	<p>A1</p>	<p>(11) International Publication Number: WO 95/29632 (43) International Publication Date: 9 November 1995 (09.11.95)</p>
--	------------------	--

(21) International Application Number: PCT/CA95/00235
 (22) International Filing Date: 21 April 1995 (21.04.95)
 (30) Priority Data:
 08/234,254 28 April 1994 (28.04.94) US
 (71) Applicant: THERATECHNOLOGIES INC. [CA/CA]; 7701, 17e avenue, Montreal, Quebec H2A 2S5 (CA).
 (72) Inventors: SAVAGE, Gary; 5625, 17e Avenue, Montreal, Quebec H1X 2R7 (CA). SWIFT, Michel; 444 Edouard Charles, Outremont, Quebec H2P 2N4 (CA).
 (74) Agent: PRINCE, Gaetan; Goudreau Gage Dubuc & Martineau Walker, 3400 The Stock Exchange Tower, P.O. Box 242, Victoria Square, Montreal, Quebec H4Z 1E9 (CA).

(81) Designated States: AM, AT, AU, BB, BG, BR, BY, CA, CH, CN, CZ, DE, DK, EE, ES, FI, GB, GE, HU, IS, JP, KE, KG, KP, KR, KZ, LK, LR, LT, LU, LV, MD, MG, MN, MW, MX, NO, NZ, PL, PT, RO, RU, SD, SE, SG, SI, SK, TJ, TM, TT, UA, UZ, VN, European patent (AT, BE, CH, DE, DK, ES, FR, GB, GR, IE, IT, LU, MC, NL, PT, SE), OAPI patent (BF, BJ, CF, CG, CI, CM, GA, GN, ML, MR, NE, SN, TD, TG), ARIPO patent (KE, MW, SD, SZ, UG).

Published
 With international search report.
 With amended claims.

(54) Title: HEADSET FOR ELECTRONIC STETHOSCOPE

(57) Abstract

The headset (11) comprises left and right elongate ear pieces (22, 23) having respective first ends to receive ear tips (20, 21) and respective, interconnected second ends (60, 61). Each ear piece (22, 23) includes a one piece elongate body (34, 35) made of flexible and resilient material and curved outwardly to skirt round the user's head when the ear tips (20, 21) are applied to a user's ears. The elongate body (34, 35) is formed with a first length of smaller cross section and therefore of greater flexibility proximate the second end (60, 61) of the corresponding ear piece (22, 23) and with a second length of lower flexibility situated between that first length and the corresponding ear tip (20, 21). Bending of the elongate bodies (34, 35) when the ear pieces (22, 23) are spread apart is therefore concentrated in the first lengths and pressure applied to the user's ears by the ear tips (20, 21) is mainly produced by the bent first lengths and transmitted to the ear tips (20, 21) through the second lengths of lower flexibility. The elongate ear pieces (22, 23) have respective second end sections (60, 61) assembled laterally adjacent to each other, and a threaded sleeve (50) is mounted on these laterally adjacent second end sections (60, 61) and is rotated and displaced longitudinally to adjust the level of pressure applied to the user's ears by the ear tips (20, 21).

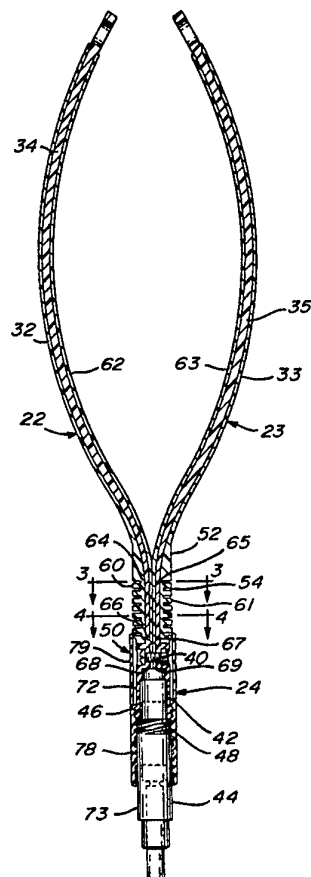

FOR THE PURPOSES OF INFORMATION ONLY

Codes used to identify States party to the PCT on the front pages of pamphlets publishing international applications under the PCT.

AT	Austria	GB	United Kingdom	MR	Mauritania
AU	Australia	GE	Georgia	MW	Malawi
BB	Barbados	GN	Guinea	NE	Niger
BE	Belgium	GR	Greece	NL	Netherlands
BF	Burkina Faso	HU	Hungary	NO	Norway
BG	Bulgaria	IE	Ireland	NZ	New Zealand
BJ	Benin	IT	Italy	PL	Poland
BR	Brazil	JP	Japan	PT	Portugal
BY	Belarus	KE	Kenya	RO	Romania
CA	Canada	KG	Kyrgystan	RU	Russian Federation
CF	Central African Republic	KP	Democratic People's Republic of Korea	SD	Sudan
CG	Congo	KR	Republic of Korea	SE	Sweden
CH	Switzerland	KZ	Kazakhstan	SI	Slovenia
CI	Côte d'Ivoire	LI	Liechtenstein	SK	Slovakia
CM	Cameroon	LK	Sri Lanka	SN	Senegal
CN	China	LU	Luxembourg	TD	Chad
CS	Czechoslovakia	LV	Latvia	TG	Togo
CZ	Czech Republic	MC	Monaco	TJ	Tajikistan
DE	Germany	MD	Republic of Moldova	TT	Trinidad and Tobago
DK	Denmark	MG	Madagascar	UA	Ukraine
ES	Spain	ML	Mali	US	United States of America
FI	Finland	MN	Mongolia	UZ	Uzbekistan
FR	France			VN	Viet Nam
GA	Gabon				

HEADSET FOR ELECTRONIC STETHOSCOPEBACKGROUND OF THE INVENTION

5

1. Field of the invention:

10 The present invention relates generally to a headset, more specifically to a headset for electronic stethoscope providing for adjustment of the pressure applied to the ears of the user by the ear tips.

15 2. Brief description of the prior art:

Many prior art methods have been used to apply with sufficient pressure the ear tips of a stethoscope to the ears of the user. One method
20 consists of interconnecting the lower ends of the two elongate ear pieces through a spring element which is deformed and tensioned when the ear pieces are spread apart to apply the ear tips to the user's ears. The ear pieces tend to return to their original position
25 to thereby hold the ear tips on the user's ears.

A drawback of this prior art method is that the level of pressure applied to the ears by the ear tips is not adjustable whereby insufficient or
30 excessive pressure may be produced. For example, excessive pressure is detrimental to the user's comfort and can even lead to tissue damage under prolonged use.

Other prior art methods have been proposed to adjust the pressure applied to the user's ears by the ear tips. However, these methods are generally complex, costly and/or difficult to implement and use. 5 An example is described in U.S. patent N° 3,746,124 granted to Wilson, deceased et al. on July 17, 1973.

OBJECTS OF THE INVENTION

10

A general object of the present invention is to overcome the above discussed drawbacks of the prior art.

15

Another object of the invention is to provide a headset in which the pressure applied to the ears by the ear tips is easily adjustable, even when the headset is worn.

20

SUMMARY OF THE INVENTION

25

More specifically, in accordance with the present invention, there is provided an ear piece for headset comprising a one-piece elongate body made of flexible and resilient material. This elongate body comprises a first end for receiving an ear tip to be 30 applied to a user's ear and a second end to be connected to the rest of the headset; it is also curved to skirt round the user's head when the ear tip is applied to the user's ear. This elongate body is

formed with a length of smaller cross section and therefore of greater flexibility proximate the second end thereof whereby bending of the elongate body for applying the ear tip to the user's ear is concentrated
5 in the length of smaller cross section and greater flexibility.

Adjustment of the pressure applied by the ear tip to the user's ear is therefore carried out at
10 the level of the length of smaller cross section and of greater flexibility.

Also in accordance with the present invention, there is provided a headset for applying
15 ear tips to a user's ears, comprising left and right elongate ear pieces each having a first end structured to receive one of the ear tips and having respective, interconnected second ends. Each ear piece comprises
20 a one-piece elongate body made of flexible and resilient material and curved outwardly to skirt round the user's head when the ear tips are applied to the user's ears. Each elongate body is formed with a first length of smaller cross section and therefore of greater flexibility proximate the second end of the
25 corresponding ear piece and with a second length of lower flexibility situated between the first length and the first end of the corresponding ear piece.

30 In operation, bending of the elongate bodies when the ear pieces are spread apart to apply the ear tips to the user's ears is concentrated in the first lengths and accordingly pressure applied to the

user's ears by the ear tips is mainly produced by the bent first lengths and transmitted from these first lengths to the ear tips through the second lengths of lower flexibility.

5

In accordance with a preferred embodiment of the invention, each first length of smaller cross section and of greater flexibility gradually passes from a first cross section of larger area to a second cross section of smaller area as the distance from the second end of the corresponding ear piece reduces.

10

According to another preferred embodiment of the present invention, the one-piece elongate body of each ear piece comprises at least one longitudinal groove to form a channel in which at least one electric wire extends from the corresponding ear tip to the second end of the corresponding ear piece. An envelope of plastic material is molded over each elongate body and therefore covers the longitudinal groove and wire.

15

20

Advantageously, each elongate body being made of flexible and resilient plastic material, the plastic material of the envelope molded over each elongate body has mechanical properties selected to reduce flexibility of the corresponding elongate body.

25

Further in accordance with the present invention, there is provided a headset for applying ear tips to a user's ears, comprising left and right elongate ear pieces each having a first end structured to receive one of the ear tips and having respective

30

second end sections. Each ear piece is curved outwardly to skirt round the user's head when the ear tips are applied to the user's ears, and is flexible and resilient over a given length thereof. The headset further comprises means for assembling the second end sections of the ear pieces laterally adjacent to each other, and means for displacing the assembling means longitudinally on the laterally adjacent second end sections to thereby adjust the level of pressure applied to the user's ears by the ear tips when the ear pieces are spread apart to apply the ear tips to the user's ears.

Preferably, the assembling means comprises a sleeve internally threaded over at least a portion of its length and mounted on the laterally adjacent second end sections, and the headset comprises a generally cylindrical outer threaded surface axial with the laterally adjacent second end sections and on which the sleeve is screwed whereby rotation of the sleeve causes longitudinal displacement of that sleeve on the laterally adjacent second end sections to thereby adjust the level of pressure applied to the user's ears by the ear tips.

The objects, advantages and other features of the present invention will become more apparent upon reading of the following non restrictive description of a preferred embodiment thereof, given by way of example only with reference to the accompanying drawings.

BRIEF DESCRIPTION OF THE DRAWINGS

In the appended drawings:

5

Figure 1 is a front elevational view of an electronic stethoscope comprising a headset in accordance with the present invention;

10

Figure 2 is an enlarged, partly cross sectional view of a pressure adjusting mechanism of the stethoscope's headset of Figure 1, comprising a sleeve mounted on the laterally adjacent lower end sections of the two elongate ear pieces of this headset;

15

Figure 3 is a cross sectional view of the headset taken along line 3-3 of Figure 2;

20

Figure 4 is a cross sectional view of the headset taken along line 4-4 of Figure 2;

25

Figure 5 is a front elevational view of the pressure adjusting mechanism of Figure 2, showing the maximum angle of deflection of an ear piece;

30

Figure 6 is a front, partly cross sectional elevational view of the pressure adjusting mechanism showing how a connector forming part of a cable of the stethoscope's thoracic coupler is assembled;

Figure 7 is a front, partly cross sectional elevational view of the pressure adjusting mechanism in a position in which the pressure applied to a user's ears by the ear tips is minimum; and

5

Figure 8 is a front, partly cross sectional elevational view of the pressure adjusting mechanism in a position in which the pressure applied to the ears of the same user is maximum.

10

DETAILED DESCRIPTION OF THE PREFERRED EMBODIMENT

15 Referring to Figure 1 of the appended drawings, a stethoscope 10 is illustrated. The stethoscope 10 comprises a headset 11, a thoracic coupler 28, and an electric cable 26 interconnecting the thoracic coupler 28 and the headset 11. The
20 headset 11 essentially comprises left and right ear tips 20 and 21, left and right elongate ear pieces 22 and 23, and a pressure adjusting mechanism 24.

In the preferred embodiment of the
25 invention, the stethoscope 10 is an electronic stethoscope. Accordingly, the thoracic coupler 28 comprises an electroacoustic transducer (not shown) for converting sounds produced by the patient's body into an electric signal, and an electronic circuit
30 (not shown) for amplifying and filtering this electric signal before it is supplied to miniature loudspeakers (not shown) encased in the ear tips 20 and 21. Therefore, the miniature loudspeakers reproduce the

sounds picked up by the thoracic coupler 28 to allow the user of the stethoscope to listen thereto.

Figure 1 also illustrates in dashed lines spreading apart of the two ear pieces 22 and 23 for applying the ear tips 20 and 21 to the user's ears. As can be seen, each ear piece 22,23 is curved outwardly to skirt round the user's head when the ear tips 20 and 21 are applied to the user's ears.

10

Referring to Figures 1 and 2, the left and right ear pieces 22 and 23 each have an upper end structured to receive the corresponding one of the ear tip 20 or 21. The ear pieces 22 and 23 further comprise lower end sections 60 and 61 assembled laterally adjacent to each other.

The ear pieces 22 and 23 are identical and each comprise a one-piece elongate inner body 34,35 made of flexible and resilient material enveloped by soft plastic material 32,33 molded over the elongate body 34,35. The elongate body 34,35 can be made for example of plastic material such as Delrin® and the soft plastic material 32,33 may comprise flexible PVC (polyvinyl chloride), rubber material, etc.

The elongate body 34,35 have a constant width (Figures 3 and 4) but gradually passes from a first larger thickness (point 62,63) to a smaller thickness (point 64,65) as the distance from lower end 68,69 of the elongate body 34,35 reduces. Between point 64,65 and point 66,67, the elongate body 34,35 has a constant thickness equal to that at point 64,65.

The elongate body 34,35 is accordingly formed with a first length of smaller cross section and therefore of greater flexibility between point 62,63 and point 66,67 and with a second length of constant cross section and of lower flexibility situated between point 62,63 and the upper end of the elongate body 34,35. Thus, bending of the elongate bodies 34 and 35 when the ear pieces 22 and 23 are spread apart (Figure 1) to apply the ear tips 20 and 21 to the user's ears is concentrated in the first lengths and pressure applied to the user's ears by the ear tips 20 and 21 is mainly produced by the bent first lengths and transmitted from these first lengths to the ear tips 20 and 21 through the second lengths of lower flexibility.

The envelope 32,33, made of soft plastic material, has a thickness that increases from point 62,63 toward the lower end 68,69 of the elongate body 34,35. More specifically, the thickness of the envelope 32,33 varies in function of the cross section of the inner elongate body 34,35 to keep the cross section of the ear piece 22,23 essentially constant from the ear tips 20 and 21 to the lower end section 60,61. Also, the soft plastic envelope 32,33 of the lower end section 60,61 defines a semicylindrical outer surface 70,71 (Figure 4). Accordingly, the soft plastic envelopes 32 and 33 of the laterally adjacent lower end sections 60 and 61 defines a cylindrical outer surface 52 of essentially constant diameter. The cylindrical surface 52 is formed with lateral, transversal grooves such as 54 to prevent interference of the envelopes 32 and 33 to bending of the elongate

bodies 34 and 35 and therefore to bending of the elongate ear pieces 22 and 23 (see Figure 1).

The main function of the envelopes 32 and
5 33 is to cover the elongate bodies 34 and 35 with soft material in order to improve the comfort of the headset's user. However, it is important to point out that the flexibility of the soft plastic material of the envelopes 32 and 33 can be reduced in view of
10 increasing the rigidity, thus reducing the flexibility of the elongate ear pieces 22 and 23. Indeed, as the elongate bodies 34 and 35, and the respective envelopes 32 and 33 can be considered as being laminated, the mechanical properties of their
15 materials can be selected to cooperate together to give a desired degree of rigidity and flexibility to the ear pieces 22 and 23.

As illustrated in Figure 2, the lower ends
20 68 and 69 of the elongate bodies 34 and 35 are interconnected through a bolt-and-nut fastener 40. The lower ends 68 and 69 of the elongate bodies 34 and 35 advantageously prolong downwardly to form respective semicylindrical extensions assembled
25 together to form a cylindrical receptacle 42 incorporating or capable of receiving an electric female connector. The receptacle 42 defines an outer cylindrical surface 72 of which the lower portion 46 is threaded.

30

The cable 26 (Figure 1) interconnecting the thoracic coupler 28 and the headset 11 is provided at the end thereof opposite to the coupler 28 with

another electric male connector 44 (Figure 2) fitting in the receptacle 42 to electrically connect the thoracic coupler 28 with the headset 11 through the cable 26. Electric connector 44 comprises a cylindrical outer surface 73 having an upper threaded portion 48. When connector 44 is inserted in receptacle 42 (Figure 2), the threaded portions 46 and 48 are longitudinally adjacent to each other to form a single continuous thread.

10

To interconnect the receptacle 42 with the miniature loudspeakers (not shown) mounted in the ear tips 20 and 21, the elongate body 34 comprise a pair of longitudinal grooves 36 and 37 (Figures 3 and 4) to receive respective wires 38 and 39. In the same manner, the elongate body 35 comprise a pair of longitudinal grooves 74 and 75 (Figures 3 and 4) to receive respective wires 76 and 77. The grooves 36, 37, 74 and 75 form longitudinal channels in which the respective electric wires 38, 39, 76 and 77 extend from the ear tips 20 and 21 to the receptacle 42. As can be appreciated, the soft plastic envelope 32 covers both the grooves 36 and 37 and the wires 38 and 39, while envelope 33 covers both the grooves 74 and 75 and the wires 76 and 77.

15

20

25

Therefore, the electric signals representative of the sounds picked up by the thoracic coupler 28 (Figure 1) are transmitted from that thoracic coupler 28 to the miniature loudspeakers (not shown) of the ear tips 20 and 21 through the cable 26, connector 44, receptacle 42, and wires 38, 39, 76 and 77.

30

The pressure adjusting mechanism 24 (Figures 1 and 2) comprises the threaded portion 46 and a hollow sleeve 50 having a lower half portion 78 internally threaded. Assembly of the sleeve 50 to the headset 11 is illustrated in Figure 6. The internally threaded portion 78 of the sleeve 50 is first screwed onto the threaded portion 46 of receptacle 42 until the sleeve 50 reaches the position of Figure 6. Male connector 44 is then inserted in the receptacle 42 and the sleeve 50 is screwed onto threaded portion 48. Of course, in the position of Figure 6, the male connector 44 can be inserted in and removed from the receptacle 42 at will. The threaded lower portion 78 of the sleeve 50 is then engaged on both the longitudinally adjacent threaded portions 46 and 48 as illustrated in Figure 2. Accordingly, a function of the sleeve 50 is to hold the male connector 44 in the receptacle 42.

Further rotation of the sleeve 50 on the threaded portions 46 and 48 will displace the sleeve 50 longitudinally along the laterally adjacent end sections 60 and 61 of the ear pieces 22 and 23. To enable longitudinal displacement of the sleeve 50, the inner diameter of the upper unthreaded portion 79 of the sleeve 50 is slightly larger than the outer diameter of the cylindrical surface 52. The sleeve 50 is rotated clockwise or counterclockwise depending on the desired axial direction of displacement.

Figures 5 and 7 show the sleeve 50 in a lowest position. In this position, the lengths of smaller diameter of the elongate bodies 34 and 35 are

situated outside the sleeve to facilitate deflection of the ear pieces 22 and 23 and to produce a weakest pressure on the ear tips 20 and 21.

5 In Figure 8, the sleeve is in the highest position. In this position, an important part of the lengths of smaller diameter and therefore of greater flexibility of the elongate bodies 34 and 35 are situated inside the sleeve 50 to render deflection of
10 the ear pieces 22 and 23 more difficult and to produce a strongest pressure on the ear pieces 22 and 23 when they are spread apart to apply the ear tips 20 and 21 on the user's ears.

15 Referring to Figures 3 and 4, the sleeve 50 is formed with a longitudinal flat surface portion 56 projecting from the inner generally cylindrical surface of the upper unthreaded sleeve portion 79, while the outer cylindrical surface 52 of the
20 laterally adjacent end sections 60 and 61 comprises front and rear diametrically opposed flat surface portions 58 and 59. At each revolution of the sleeve 50, the inner flat surface portion 56 of the sleeve 50 will deform the envelopes 32 and 33 of soft plastic
25 material to cause resistance to rotation of the sleeve 50 and to releasably block the sleeve 50 in position on the laterally adjacent second end sections 60 and 61 when the inner flat surface portion 56 is applied to one of the outer flat surface portion 58 or 59.
30 This will prevent undesirable rotation of the sleeve 50 leading to a change in the adjustment of the pressure applied to the user's ears by the ear tips 20 and 21.

Undesirable rotation of the sleeve 50 can also be prevented through friction by appropriately dimensioning the inner diameter of the sleeve 50 and to outer diameter of the cylindrical surface 52, and/or by appropriately dimensioning the respective diameters of the threaded portions 46, 48 and 78.

Although the present invention has been described hereinabove by way of a preferred embodiment thereof, this embodiment can be modified at will, within the scope of the appended claims, without departing from the spirit and nature of the subject invention.

WHAT IS CLAIMED IS:

1. An ear piece for headset comprising
5 a one-piece elongate body made of flexible and resilient material, said elongate body comprising a first end for receiving an ear tip to be applied to a user's ear and a second end to be connected to the rest of the headset, said elongate body being curved
10 to skirt round the user's head when the ear tip is applied to the user's ear, and said elongate body being formed with a length of smaller cross section and therefore of greater flexibility proximate said second end whereby bending of the elongate body for
15 applying the ear tip to the user's ear is concentrated in said length of smaller cross section and greater flexibility.

2. An ear piece for headset as defined
20 in claim 1, wherein said length of smaller cross section and of greater flexibility of the elongate body gradually passes from a first cross section of larger area to a second cross section of smaller area as the distance from said second end reduces.

25 3. An ear piece for headset as defined in claim 1, wherein said flexible and resilient material of the elongate body comprises plastic material.

30 4. An ear piece for headset as defined in claim 1, wherein said elongate body comprises at least one longitudinal groove to form a longitudinal channel in which at least one electric wire extends
35 from the ear tip to said second end of the elongate body.

5. An ear piece for headset as defined in claim 4, further comprising an envelope of soft material molded over said elongate body, said envelope covering said at least one longitudinal groove and said at least one electric wire.

6. An ear piece for headset as defined in claim 1, wherein the elongate body is made of flexible and resilient plastic material, wherein an envelope of plastic material is molded over said elongate body, and wherein the plastic material of said envelope has mechanical properties selected to reduce flexibility of said elongate body.

7. A headset for applying ear tips to a user's ears, comprising left and right elongate ear pieces each having a first end structured to receive one of the ear tips and having respective, interconnected second ends, each of said ear pieces comprising a one-piece elongate body made of flexible and resilient material and curved outwardly to skirt round the user's head when the ear tips are applied to the user's ears, wherein each elongate body is formed with a first length of smaller cross section and therefore of greater flexibility proximate the second end of the corresponding ear piece and with a second length of lower flexibility situated between said first length and said first end of the corresponding ear piece, whereby bending of the elongate bodies when the ear pieces are spread apart to apply the ear tips to the user's ears is concentrated in said first lengths and whereby pressure applied to the user's ears by the ear tips is mainly produced by the bent first lengths and transmitted from said first lengths to the ear tips through said second lengths of lower flexibility.

8. A headset as recited in claim 7, wherein each first length of smaller cross section and of greater flexibility gradually passes from a first cross section of larger area to a second cross section of smaller area as the distance from said second end of the corresponding ear piece reduces.

9. A headset as recited in claim 7, wherein the one-piece elongate body of each ear piece comprises at least one longitudinal groove to form a channel in which at least one electric wire extends from the corresponding ear tip to the second end of the corresponding ear piece.

10. A headset as recited in claim 9, further comprising an envelope of soft material molded over each elongate body, each envelope of soft material covering said at least one longitudinal groove and said at least one electric wire of the corresponding one-piece elongate body.

11. A headset as recited in claim 10, wherein each envelope of soft material comprises an envelope portion for enveloping the first length of the corresponding elongate body, said envelope portion comprising transversal outer grooves to facilitate bending of the envelope portion upon bending of the first length of the corresponding elongate body.

12. A headset as recited in claim 7, wherein each elongate body is made of flexible and resilient plastic material, wherein an envelope of plastic material is molded over each elongate body, and wherein the plastic material of each envelope has mechanical properties selected to reduce flexibility of the corresponding elongate body.

13. A headset for applying ear tips to a user's ears, comprising left and right elongate ear pieces each having a first end structured to receive one of the ear tips and having respective second end sections, each of said ear pieces being curved outwardly to skirt round the user's head when the ear tips are applied to the user's ears, and being flexible and resilient over a given length thereof, said headset further comprising means for assembling said second end sections of the ear pieces laterally adjacent to each other, and means for displacing said assembling means longitudinally on the laterally adjacent second end sections to thereby adjust the level of pressure applied to the user's ears by the ear tips when the ear pieces are spread apart to apply the ear tips to the user's ears.

14. The headset of claim 13, wherein each of said ear pieces comprises a one-piece elongate body made of flexible and resilient material and having a first length of smaller cross section and therefore of greater flexibility in the region of the second end section of the corresponding ear piece, and having a second length of lower flexibility situated between said first length and said first end of the corresponding ear piece, whereby bending of the elongate bodies when the ear pieces are spread apart to apply the ear tips to the user's ears is concentrated in said first lengths and whereby pressure applied to the user's ears by the ear tips is mainly produced by the bent first lengths and transmitted from said first lengths to the ear tips through said second lengths of lower flexibility.

15. The headset of claim 13, wherein said assembling means comprises a sleeve internally

threaded over at least a portion of its length and mounted on the laterally adjacent second end sections, and wherein said headset comprises a generally cylindrical outer threaded surface axial with said laterally adjacent second end sections and on which the sleeve is screwed whereby rotation of said sleeve causes longitudinal displacement of said sleeve on the laterally adjacent second end sections to thereby adjust the level of pressure applied to the user's ears by the ear tips.

16. The headset of claim 15, further comprising means for preventing undesirable rotation of said sleeve after the level of pressure applied to the user's ears by the ear tips has been adjusted.

17. The headset of claim 16, wherein said sleeve comprises an inner generally cylindrical surface, wherein each of said ear pieces comprises an envelope of soft material molded over the corresponding elongate body, and wherein said means for preventing undesirable rotation of the sleeve comprises said sleeve formed with an inner flat surface portion projecting from said inner generally cylindrical surface and at least one of said envelopes formed with an outer flat surface portion complementary to said inner flat surface portion, and wherein, at each revolution of the sleeve, the inner flat surface portion will deform said envelopes of soft material to cause resistance to rotation of the sleeve and to releasably block the sleeve in position on the laterally adjacent second end sections when the inner and outer flat surface portions are applied to each other.

18. The headset of claim 14, wherein the one-piece elongate body of each ear piece comprises at least one longitudinal groove to form a channel in which electric wires extend from the corresponding ear tip to the second end of the corresponding ear piece.

19. The headset of claim 18, wherein each ear piece comprises an envelope of soft material molded over the corresponding elongate body, each envelope of soft material covering said at least one longitudinal groove and said electric wires of the corresponding one-piece elongate body.

20. The headset of claim 15, wherein the laterally adjacent second end sections comprise a free end provided with a receptacle capable of receiving an electric connector comprising an outer threaded surface that can be screwed into the internally threaded sleeve to retain said electric connector in said receptacle.

AMENDED CLAIMS

[received by the International Bureau on 17 October 1995 (17.10.95);
original claims 2,3,5,6,8,10-12,14,16,17,19 and 20 cancelled;
original claims 1,4,7,9,13,15 and 18 amended; new claims 2 and 5 added;
original claims 4,7,9,13,15 and 18 renumbered 3,4,6,7,8 and 9 (4 pages)]

1. An ear piece for headset for applying an ear tip to a user's ear, comprising a bendable elongate body made of flexible and resilient plastic material, said elongate body being curved to skirt round the user's head when the ear tip is applied to the user's ear, and said elongate body comprising:

a proximate end to be connected to the headset;

a distal end structured to receive the ear tip;

a weakened first portion proximate said proximate end; and

a second portion situated between said distal end and the weakened first portion;

wherein the weakened first portion has a first flexibility and the second portion has a second flexibility lower than said first flexibility whereby bending of the elongate body for applying the ear tip to the user's ear is concentrated in said weakened first portion.

2. An ear piece for headset as defined in claim 1, wherein the weakened first portion comprises transversal outer grooves to facilitate bending of the weakened first portion.

3. An ear piece for headset as defined in claim 1, further comprising at least one electric wire, wherein said elongate body comprises at least one longitudinal channel in which said at least one electric wire extends from said proximate end to said distal end of the elongate body.

4. A headset for applying ear tips to a user's ears, comprising left and right elongate ear pieces each having a distal end structured to receive one of the ear tips and having respective, interconnected proximate ends, each of said ear pieces comprising a bendable elongate body made of flexible and resilient plastic material and curved outwardly to skirt round the user's head when the ear tips are applied to the user's ears, wherein each elongate body comprises:

a weakened first portion proximate said proximate end of the corresponding ear piece; and

a second portion situated between said first portion and said distal end of the corresponding ear piece;

wherein said first portion has a first flexibility and said second portion has a second flexibility lower than said first flexibility whereby bending of the elongate bodies when the ear pieces are spread apart to apply the ear tips to the user's ears is concentrated in said weakened first portions and whereby pressure applied to the user's ears by the ear tips is mainly produced by the bent first portions and

transmitted from said first portions to the ear tips through said second portions.

5. A headset as recited in claim 4, wherein the weakened first portion of each elongate body comprises transversal outer grooves to facilitate bending of said weakened first portion.

6. A headset as recited in claim 4, wherein each ear piece comprises at least one electric wire, and wherein the elongate body of each ear piece comprises at least one longitudinal channel in which said at least one electric wire of said ear piece extends from the distal end to the proximate end of said ear piece.

7. A headset as recited in claim 4, further comprising a sleeve member in which the weakened first portions of the elongate bodies of the left and right ear pieces are mounted laterally adjacent to each other, the sleeve member comprising means for displacing said sleeve member longitudinally on the laterally adjacent weakened first portions to thereby adjust the level of pressure applied to the user's ears by the ear tips when the ear pieces are spread apart to apply the ear tips to the user's ears.

8. The headset of claim 7, wherein said sleeve member comprises a sleeve internally threaded over at least a portion of its length, and wherein

said headset comprises a generally cylindrical externally threaded sleeve-receiving member axial with said laterally adjacent weakened first portions and on which the sleeve is screwed whereby rotation of said sleeve causes longitudinal displacement of said sleeve on the laterally adjacent weakened first portions to thereby adjust the level of pressure applied to the user's ears by the ear tips.

9. The headset of claim 8, wherein each ear piece comprises at least one electric wire, and wherein the elongate body of each ear piece comprises at least one longitudinal channel in which said at least one electric wire of said ear piece extends from the distal end to the proximate end of said ear piece.

AMENDED SHEET (ARTICLE 19)

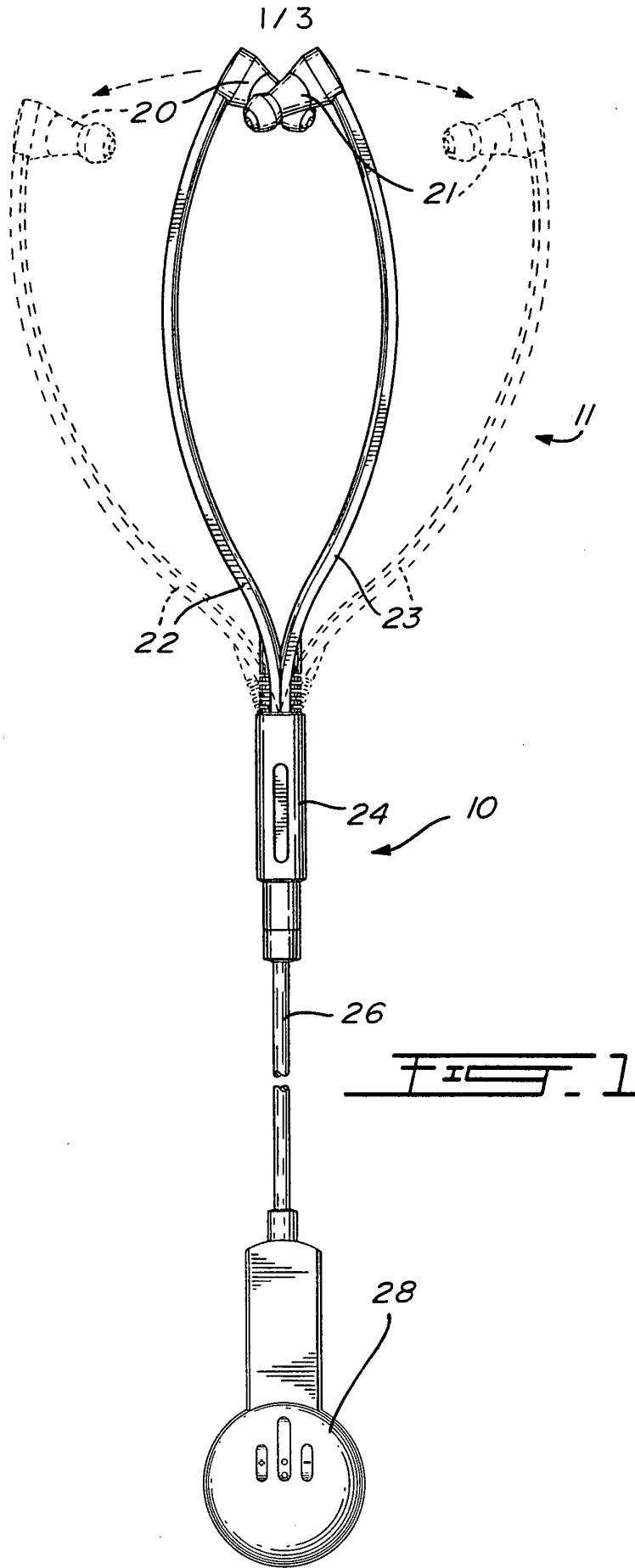

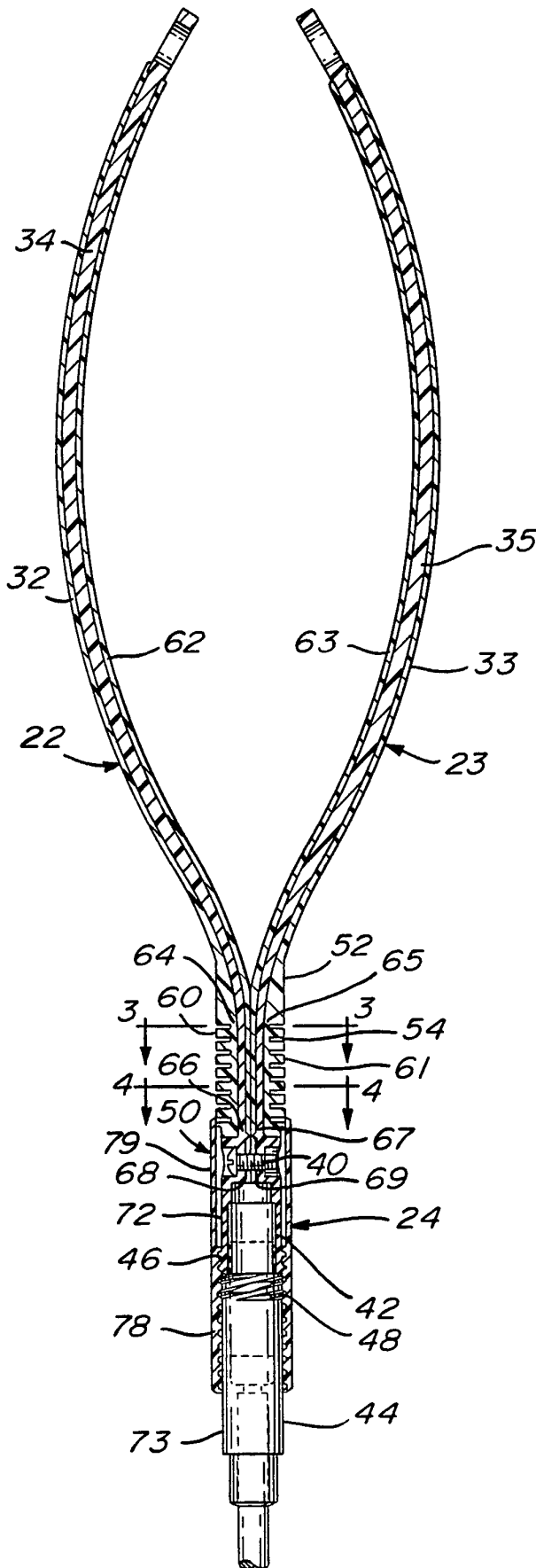

FIG. 2

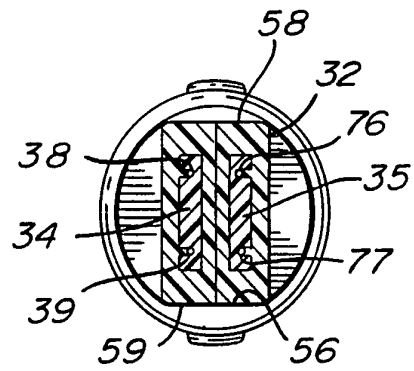

FIG. 3

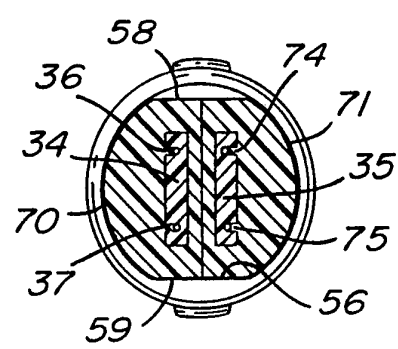

FIG. 4

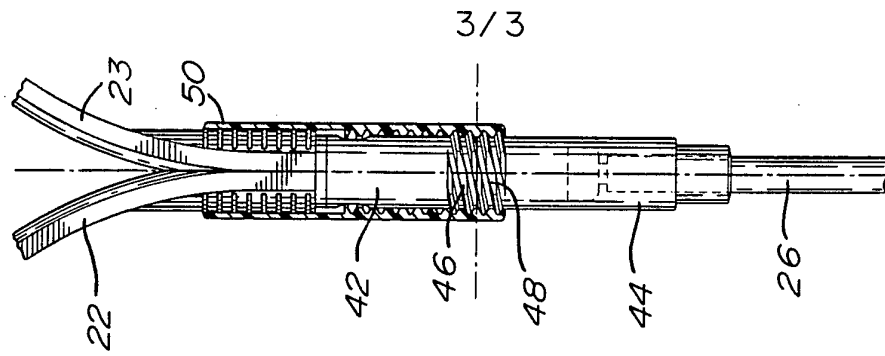

FIG. 8

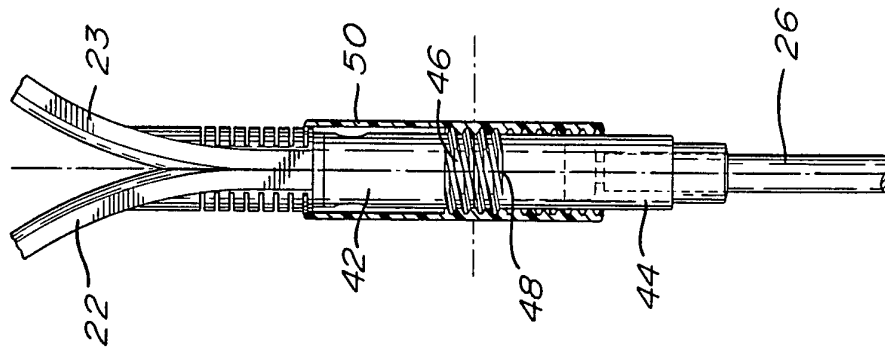

FIG. 7

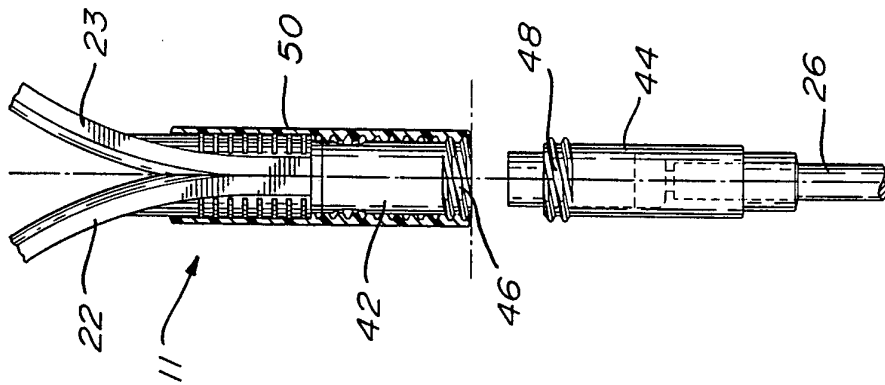

FIG. 6

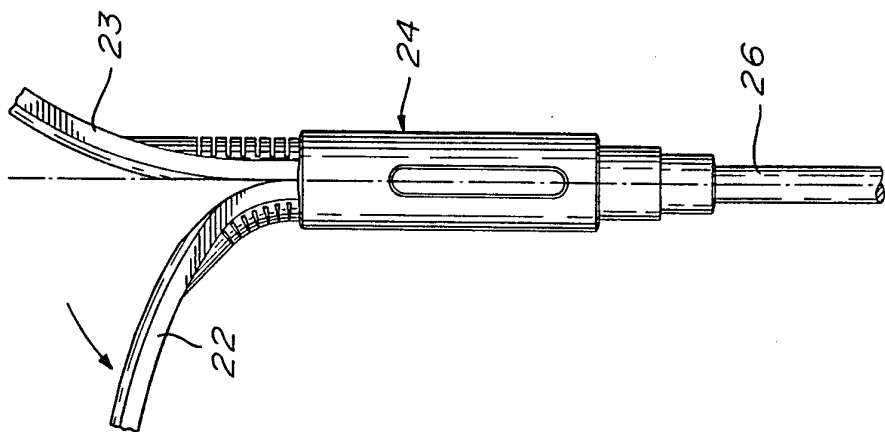

FIG. 5

INTERNATIONAL SEARCH REPORT

International Application No
PCT/CA 95/00235

A. CLASSIFICATION OF SUBJECT MATTER
IPC 6 A61B7/04 H04R1/10

According to International Patent Classification (IPC) or to both national classification and IPC

B. FIELDS SEARCHED

Minimum documentation searched (classification system followed by classification symbols)
IPC 6 A61B H04R G10K

Documentation searched other than minimum documentation to the extent that such documents are included in the fields searched

Electronic data base consulted during the international search (name of data base and, where practical, search terms used)

C. DOCUMENTS CONSIDERED TO BE RELEVANT

Category *	Citation of document, with indication, where appropriate, of the relevant passages	Relevant to claim No.
X	DE,A,22 27 673 (KIRCHNER) 10 January 1974 see page 2, line 4 - line 28 see page 4, line 27 - page 5, line 20 see figures	1,7
A	---	2,8,13, 14
X	DE,A,39 09 011 (GERDING ET AL.) 5 October 1989 see column 1, line 66 - column 3, line 1 see figures	13
A	---	15,16
A	US,A,3 829 624 (GOODIN ET AL.) 13 August 1974 see column 2, line 66 - column 3, line 52 see figures 1-3	1-3,6-8, 12-14

	-/--	

Further documents are listed in the continuation of box C.

Patent family members are listed in annex.

* Special categories of cited documents :

- "A" document defining the general state of the art which is not considered to be of particular relevance
- "E" earlier document but published on or after the international filing date
- "L" document which may throw doubts on priority claim(s) or which is cited to establish the publication date of another citation or other special reason (as specified)
- "O" document referring to an oral disclosure, use, exhibition or other means
- "P" document published prior to the international filing date but later than the priority date claimed

- "T" later document published after the international filing date or priority date and not in conflict with the application but cited to understand the principle or theory underlying the invention
- "X" document of particular relevance; the claimed invention cannot be considered novel or cannot be considered to involve an inventive step when the document is taken alone
- "Y" document of particular relevance; the claimed invention cannot be considered to involve an inventive step when the document is combined with one or more other such documents, such combination being obvious to a person skilled in the art.
- "&" document member of the same patent family

Date of the actual completion of the international search

1 August 1995

Date of mailing of the international search report

17.08.95

Name and mailing address of the ISA

European Patent Office, P.B. 5818 Patentlaan 2
NL - 2280 HV Rijswijk
Tel. (+ 31-70) 340-2040, Tx. 31 651 epo nl,
Fax (+ 31-70) 340-3016

Authorized officer

Chen, A

INTERNATIONAL SEARCH REPORT

In tional Application No
PCT/CA 95/00235

C.(Continuation) DOCUMENTS CONSIDERED TO BE RELEVANT

Category *	Citation of document, with indication, where appropriate, of the relevant passages	Relevant to claim No.
A	<p>US,A,3 681 540 (THOMSON) 1 August 1972</p> <p>see column 2, line 58 - column 5, line 8</p> <p>see figures 1,2,5,8,9</p> <p>-----</p>	<p>1,4-7,9, 10,14, 18,19</p>

INTERNATIONAL SEARCH REPORT

Information on patent family members

International Application No

PCT/CA 95/00235

Patent document cited in search report	Publication date	Patent family member(s)	Publication date
DE-A-2227673	10-01-74	NONE	
DE-A-3909011	05-10-89	DE-U- 8803781	05-05-88
US-A-3829624	13-08-74	NONE	
US-A-3681540	01-08-72	NONE	