



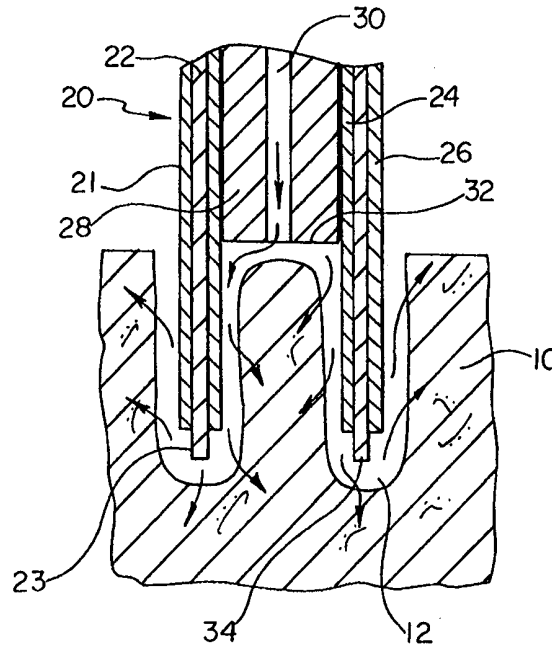
INTERNATIONAL APPLICATION PUBLISHED UNDER THE PATENT COOPERATION TREATY (PCT)

<p>(51) International Patent Classification <sup>6</sup> : <b>A61B 17/39</b></p>	<p><b>A1</b></p>	<p>(11) International Publication Number: <b>WO 99/44523</b> (43) International Publication Date: 10 September 1999 (10.09.99)</p>
<p>(21) International Application Number: PCT/US99/04942 (22) International Filing Date: 5 March 1999 (05.03.99) (30) Priority Data: 09/035,736 5 March 1998 (05.03.98) US (71) Applicant: SCIMED LIFE SYSTEMS, INC. [US/US]; One SciMed Place, Maple Grove, MN 55311 (US). (72) Inventors: ELLIS, Louis; 3004 Armour Terrace, St. Anthony, MN 55418 (US). HENDRICKSON, Gary, L.; 25216 184th Street, Big Lake, MN 55309 (US). DEVORE, Lauri; 17036-13 Avenue Northeast, Seattle, WA 98155 (US). (74) Agents: SEAGER, Glenn, M. et al.; Crompton, Seager &amp; Tufte, LLC, Suite 895, 331 Second Avenue South, Minneapolis, MN 55401 (US).</p>		<p>(81) Designated States: CA, JP, European patent (AT, BE, CH, CY, DE, DK, ES, FI, FR, GB, GR, IE, IT, LU, MC, NL, PT, SE).  <b>Published</b> <i>With international search report.</i></p>

(54) Title: PMR DEVICE AND METHOD

(57) Abstract

A catheter (20) having an elongate shaft (21) including a proximal and a distal end. The shaft (21) includes a conductor (22). An electrode (23) is disposed at the distal end of the shaft (21) and is connected to the conductor (22). The electrode (23) has a generally annular, cross-sectional shape. The annular shape defines an opening within the electrode. An insulator (26) surrounds the conductor (22). In accordance with the method of the present invention, a crater wound (12) can be formed through the endocardium and into the myocardium of a patient's heart (10). Collateral damage to the myocardium can be made by infusing pressurized fluid into the crater wound (12).



**FOR THE PURPOSES OF INFORMATION ONLY**

Codes used to identify States party to the PCT on the front pages of pamphlets publishing international applications under the PCT.

AL	Albania	ES	Spain	LS	Lesotho	SI	Slovenia
AM	Armenia	FI	Finland	LT	Lithuania	SK	Slovakia
AT	Austria	FR	France	LU	Luxembourg	SN	Senegal
AU	Australia	GA	Gabon	LV	Latvia	SZ	Swaziland
AZ	Azerbaijan	GB	United Kingdom	MC	Monaco	TD	Chad
BA	Bosnia and Herzegovina	GE	Georgia	MD	Republic of Moldova	TG	Togo
BB	Barbados	GH	Ghana	MG	Madagascar	TJ	Tajikistan
BE	Belgium	GN	Guinea	MK	The former Yugoslav Republic of Macedonia	TM	Turkmenistan
BF	Burkina Faso	GR	Greece			TR	Turkey
BG	Bulgaria	HU	Hungary	ML	Mali	TT	Trinidad and Tobago
BJ	Benin	IE	Ireland	MN	Mongolia	UA	Ukraine
BR	Brazil	IL	Israel	MR	Mauritania	UG	Uganda
BY	Belarus	IS	Iceland	MW	Malawi	US	United States of America
CA	Canada	IT	Italy	MX	Mexico	UZ	Uzbekistan
CF	Central African Republic	JP	Japan	NE	Niger	VN	Viet Nam
CG	Congo	KE	Kenya	NL	Netherlands	YU	Yugoslavia
CH	Switzerland	KG	Kyrgyzstan	NO	Norway	ZW	Zimbabwe
CI	Côte d'Ivoire	KP	Democratic People's Republic of Korea	NZ	New Zealand		
CM	Cameroon			PL	Poland		
CN	China	KR	Republic of Korea	PT	Portugal		
CU	Cuba	KZ	Kazakstan	RO	Romania		
CZ	Czech Republic	LC	Saint Lucia	RU	Russian Federation		
DE	Germany	LI	Liechtenstein	SD	Sudan		
DK	Denmark	LK	Sri Lanka	SE	Sweden		
EE	Estonia	LR	Liberia	SG	Singapore		

## PMR DEVICE AND METHOD

### Related Applications

The present application is related to U.S. Provisional Patent Application  
Serial No. 60/064,210, filed on November 4, 1997, and entitled  
5 TRANSMYOCARDIAL REVASCULARIZATION GROWTH FACTOR  
MEDIUMS AND METHOD, U.S. Patent Application Serial No. 08/812,425,  
filed on March 6, 1997, entitled TRANSMYOCARDIAL  
REVASCULARIZATION CATHETER AND METHOD, U.S. Patent  
Application Serial No. 08/810,830, filed March 6, 1997, entitled  
10 RADIOFREQUENCY TRANSMYOCARDIAL REVASCULARIZATION  
APPARATUS AND METHOD, and U.S. Patent Application Serial No.  
\_\_\_\_\_, filed on March 5, 1998, and entitled EXPANDABLE PMR  
DEVICE AND METHOD herein incorporated by reference.

15

### Field of the Invention

The present invention relates generally to medical devices for forming  
holes in heart chamber interior walls in percutaneous myocardial  
revascularization (PMR) procedures. More specifically, the present invention  
relates to intravascular PMR devices having generally annular tips.

20

### Background of the Invention

A number of techniques are available for treating cardiovascular disease  
such as cardiovascular by-pass surgery, coronary angioplasty, laser angioplasty

and atherectomy. These techniques are generally applied to by-pass or open lesions in coronary vessels to restore and increase blood flow to the heart muscle. In some patients, the number of lesions are so great, or the location so remote in the patient vasculature that restoring blood flow to the heart muscle is difficult.

5 Percutaneous myocardial revascularization (PMR) has been developed as an alternative to these techniques which are directed at by-passing or removing lesions.

Heart muscle may be classified as healthy, hibernating and "dead". Dead tissue is not dead but is scarred, not contracting, and no longer capable of contracting even if it were supplied adequately with blood. Hibernating tissue is not contracting muscle tissue but is capable of contracting, should it be adequately re-supplied with blood. PMR is performed by boring channels directly into the myocardium of the heart.

10

PMR was inspired in part by observations that reptilian hearts muscle is supplied primarily by blood perfusing directly from within heart chambers to the heart muscle. This contrasts with the human heart, which is supplied by coronary vessels receiving blood from the aorta. Positive results have been demonstrated in some human patients receiving PMR treatments. These results are believed to be caused in part by blood flowing from within a heart chamber through patent channels formed by PMR to the myocardial tissue. Suitable PMR holes have been burned by laser, cut by mechanical means, and burned by radio frequency current devices. Increased blood flow to the myocardium is also believed to be caused in part by the healing response to wound formation. Specifically, the

15

20

formation of new blood vessels is believed to occur in response to the newly created wound.

#### Summary of the Invention

The present invention pertains to a device and method for performing  
5 percutaneous myocardial revascularization (PMR). The device of the present invention can be used to form crater wounds in the myocardium of the patient's heart. A crater wound can be viewed as a wound having a width greater than its depth, whereas a channel wound is one having a depth greater than its width. A hole in the myocardium is a volumetric removal of tissue. The device can also be  
10 used to form channel wounds, but the configuration of the device's electrode(s) makes the device particularly suitable for creating crater wounds.

In the preferred form of the method in accordance with the present invention, a crater wound is made through the endocardium and into the myocardium. The wound, and thus the healing response, including angiogenesis  
15 and subsequent perfusion of tissue is enhanced by collateral damage to the myocardium. The collateral damage is preferably induced by directing pressurized saline, contrast media, drug or a combination into the crater site through the endocardium and into the myocardium. This causes the vessels, capillaries and sinuses to rupture. By creating the collateral damage, the number  
20 of wounds which need to be made during the PMR procedure can be substantially reduced as the size of each wound is increased in view of the collateral damage. Additionally, and arguably as significant as the reduction in the number of wounds which must be formed during the procedure, is the reduction of the

likelihood of a myocardial perforation. This reduction is possible because the holes can be limited in depth to just through the endocardium. Once the endocardium is perforated, pressure from infused fluid can rupture the myocardial vessels without further ablation or removal of tissue.

5 In a preferred embodiment, a catheter in accordance with the present invention includes an elongate shaft having a proximal end and a distal end, and a conductor extending therethrough. An electrode is disposed at the distal end of the shaft and connected to the conductor. The electrode has a generally annular transverse cross-sectional shape. The annular shape defines an opening within the  
10 electrode. An insulator surrounds the elongate shaft.

A stop is disposed in the opening a predetermined distance proximally of the distal end of the electrode. The shaft preferably defines a lumen in fluid communication with the opening through the electrode. In one embodiment, a needle can be disposed within the opening and be in fluid communication with the  
15 lumen to deliver contrast media, growth factors or drugs to the wound.

In another embodiment, the annular shape of the electrode is generally circular. The annular shape can be continuous or in an alternate embodiment, discontinuous and formed from a plurality of discrete electrodes positioned in an array. The electrode can also include a serrated edge that produces a plurality of  
20 electrode contact points.

A method for performing PMR in accordance with the present invention includes providing a catheter having an elongate shaft including a proximal end and a distal end. A generally annular shaped electrode is disposed at the distal

end of the shaft. The electrode is advanced to proximate the endocardial surface of the myocardium of the patient's heart. The electrode is energized and advanced into the myocardium to form an annular shaped crater wound. Depth is controlled by a mechanical stop.

5

#### Brief Description of the Drawings

Figure 1 is a cross-sectional, perspective view of an annular shaped crater wound in a patient's myocardium formed by a device in accordance with the present invention;

10        Figure 2 is a perspective, cross-sectional view of a catheter in accordance with the present invention;

Figure 3 is a cross-sectional view of the catheter of Figure 2 in use;

Figure 4 is a perspective, cross-sectional view of an alternate embodiment of the catheter in accordance with the present invention;

15        Figure 5 is a cross-sectional view of the catheter of Figure 4 in use;

Figure 6 is a perspective view of the distal end of yet another alternate embodiment of a catheter in accordance with the present invention;

Figure 7 is a perspective view of yet another alternate embodiment of the catheter in accordance with the present invention;

20        Figure 8 is a perspective view of yet another alternate embodiment of the catheter in accordance with the present invention;

Figure 9 is a perspective view of yet another alternate embodiment of the catheter in accordance with the present invention;

Figure 10 is a cross-sectional view of the catheter of Figure 8;

Figure 11 is a cross-sectional view of the catheter of Figure 8;

Figure 12 is a cross-sectional view of the catheter of Figure 8;

Figure 13 is a top view of a crater formed in the endocardium;

5 Figure 14 is a cross-sectional view of the crater of Figure 12;

Figure 15 is a front view of a catheter electrode in accordance with the present invention;

Figure 16 is a back view of the electrode of Figure 14;

Figure 17 is a side view of the electrode of Figure 14;

10 Figure 18 is a front view of yet another embodiment of an electrode in accordance with the present invention; and

Figure 19 is a back view of the electrode of Figure 17.

#### Detailed Description of the Invention

15 Referring now the drawings wherein like reference numerals refer to like elements throughout the several views, Figure 1 is a perspective, partial cross-sectional view of a heart wall 10 having an annular hole 12 formed in the myocardium by a catheter made in accordance with the present invention. Figure 20 2 is a perspective, partial cross-sectional view of a catheter 20 in accordance with the present invention. Catheter 20 includes a shaft 21 having a proximal end and a distal end. Shaft 21 preferably includes an elongate hypotube sandwiched between an inner insulator 24 and an outer insulator 26. Hypotube 22 can be formed from stainless steel or Nitinol or other conductive material. It can be



desirable to use a Nitinol hypotube as the highly flexible material can act as a shock absorber while catheter 20 is pressured against the beating heart during the PMR procedure. Insulators 24 and 26 may be formed from, for example, polyethylene, polyimide or PTFE. Those skilled in the art would appreciate that other biocompatible materials can be used to form these elements. The distal end of hypotube 22 is preferably left uninsulated to form an annularly-shaped electrode 23.

A stop 28 is preferably disposed within shaft 21. Stop 28 preferably defines a lumen 30 extending therethrough. Stop 28 includes a distal end 32 spaced a predetermined distance from a distal end 34 of electrode 23. This predetermined distance can be used to control the depth of holes 12 formed in the myocardium of a patient's heart. Those skilled in the art will recognize the non-conductive, biocompatible materials available to form stop 28, for example PEPI.

In view of the discussion below regarding the use of catheter 20, those skilled in the art of catheter construction would recognize the various possibilities for manifolds to be disposed at the proximal end of catheter 20, and that a suitable radio frequency (RF) generator can be conductively connected to hypotube 22 to deliver RF energy to electrode 23.

Figure 3 is a cross-sectional view of catheter 20 in use. In Figure 3, electrode 23 has been energized with RF energy and advanced into heart wall 10 to form hole 12. As shown by the arrows, contrast medium, growth factor or other drugs are being infused through lumen 30 into hole 12, and then into myocardium 10. It can be noted that in Figure 3 that distal end 32 of stop 28 is

spaced a predetermined distance from distal end 34 of electrode 23 such that the depth of hole 12 is approximately equal to its width. The predetermined distance can be varied such that shallower holes or craters are formed, or alternatively the distance can be increased to form channels.

5           Figure 4 is a perspective, partial cross-sectional view of catheter 20 modified to include a hypotube 36 extending distally from lumen 30. The distal end of hypotube 36 includes a sharpened end 38, and a lumen defined therethrough in fluid communication with lumen 30. Hypotube 36 can also act as a bi-polar ground

10           Figure 5 is a cross-sectional view of catheter 20 including hypotube 36. This view is similar to that of Figure 3, except that rather than infusion fluid into hole 12, as shown by the arrows, fluid is directed into the myocardium.

          Figure 6 is an alternate embodiment of a catheter 120 in accordance with the present invention. Many elements of catheter 120 are similar to that of catheter 20 as shown in Figure 2. Rather than shaft 121 including a hypotube 22, shaft 121 includes a plurality of elongate conductive members 122 embedded in a tubular insulator 124. A distal portion of members 122 is preferably left uninsulated to form a generally annularly shaped array of electrodes 123. A stop 128 is disposed within tubular member 124. Stop 128 defines a lumen 130  
15           extending therethrough. Stop 128 includes distal end 132 spaced a predetermined distance proximally of distal ends 134 at electrodes 123 to control the depth of the holes created by catheter 123. It can be appreciated by those skilled in the art that catheter 120 can be used in substantially the same manner to perform PMR as  
20

catheter 20 shown in Figure 3. A plurality of electrodes, having a surface area less than a continuous annular electrode requires less energy to arc or ablate. A plurality of electrodes will also tend to grab tissue, stabilizing the electrode on a moving heart wall.

5           Figure 7 is a perspective view of a modified embodiment of catheter 20 of Figure 2. In particular, the distal end of hypotube 22 has been serrated to form a serrated electrode 40. Serrating electrode 40 changes the surface of the electrode contacting the tissue and thus reduces the power needed to arc. Serrated electrode 40 will also grab tissue, securing electrode 40 to a moving heart wall during crater  
10 formation.

          Figure 8 is a view of yet another embodiment of catheter 20 in accordance with the present invention. To catheter 20 has been added a second grounded or return electrode 31 to form a bi-polar RF PMR catheter. It can be appreciated that this electrode can also be added to catheter 120 of Figure 6 and catheter 20 of  
15 Figure 7 to make each of these embodiments bi-polar as well.

          Figure 9 is a perspective view of yet another embodiment of a catheter 210 in accordance with the present invention disposed within a guide catheter 212. Catheter 210 includes an elongate shaft 214. Elongate shaft 214 is preferably formed from an elongate tubular, and conductive member such as a stainless steel  
20 or Nitinol hypotube. Shaft 214 defines an infusion lumen therethrough. The wall of the lumen and the exterior shaft 214 are preferably insulated, by a layer of, for example, polyethylene. An electrode 216 is connected to shaft 214 by solder or another conductive connection.

Electrode 216 can be formed from a wire or ribbon shaped member which extends distally from shaft 214 to a generally linearly and transversely extending distal end 218. All but distal end 218 of electrode 216 can be insulated with, for example, PTFE to focus RF energy at end 218. Electrode 216 can be partially or  
5 completely surrounded by a hood 220 extending from shaft 214. Hood 220 preferably defines an infusion lumen in fluid communication with the infusion lumen of shaft 214. All or a portion of electrode 216 can be disposed in the infusion lumen. Hood 220 includes a distal end 222. Distal end 218 could be plated with gold or other radiopaque material to act as a marker.

10 Figure 10 is a cross-sectional view of hood 220 showing electrode 218 extending distally beyond distal end 222. By contrast, in Figure 11, electrode 216 is entirely disposed proximally of end 222. In Figure 12, distal end 218 of electrode 216 is disposed flush with end 222 of hood 220. The relative positioning of hood 220 and electrode 216 can have an effect on the depth of  
15 craters formed by catheter 210, as explained in more detail below.

Figure 13 is a view directly into a crater 223 formed by a typical electrode 218 viewed from a perspective perpendicular to a surface 224 of endocardium 226. Crater 223 extends into myocardium 228 of a patient's heart. Figure 14 is a cross-sectional view of crater 223 of Figure 13.

20 The depth D of crater 223 is a function of the power delivered to electrode 216 and the relative position of the electrode 216 to distal end 222 of hood 220. The more power delivered to electrode 216, the greater the depth of crater 223. With respect to the position of electrode 216 relative to hood 220, the position of

electrode distal end 218 relative hood distal end 222 of Figure 10 creates the deepest crater. The positioning shown in Figure 11 would create the shallowest, whereas the positioning of Figure 12 would create a crater of intermediate depth.

The width  $W$  of crater 223 is a function of the transverse extent of distal end 218 of electrode 216, and the power delivered to the electrode. The greater the transverse extent of distal end 218, the greater the width of crater 223. The more power that is delivered to electrode 216, the wider will be crater 223.

In use, catheter 210 is preferably advanced percutaneous to the endocardium of a patient's heart. This route will normally be by way of the femoral artery and the aorta to the left ventricle. Distal end 222 is brought into contact with the endocardium, preferably, such that the perimeter of distal end 222 is entirely in contact with the endocardium. Electrode 216 disposed in one of the positions shown in Figures 10-12, is energized to form a crater. A fluid under pressure is then forced into the crater by way of the infusion lumen through shaft 214 and hood 220. This fluid can be saline, contrast media, a drug or any combination of these. By forcing fluid under pressure into the myocardium, the vessels, capillaries, and sinuses will be collaterally damaged within an area 230 about crater 223. This will increase the healing response by angiogenesis associated with the crater. The likelihood of perforating the myocardium is reduced as the depth of the crater need only be sufficient to penetrate the endocardium.

The following are exemplary technical specifications for catheter 210 as configured in Figure 12:

- A. Output power vs. impedance specifications-channel or crater making PMR device;
1. Output power vs. impedance is preferably flat across a wide range of impedance values for desired therapeutic power level.
  - 5 2. Exemplary power requirements: a) output power approximately 30-40 watts into 100 to 10,000 ohms; b) output voltage approximately 1,200 to 2,000 V P-P into approximately 100 to 10,000 ohms; c) output current approximately 100 to 300 ma P-P into about 100 to 10,000 ohms voltage is preferably large enough  
10 to sustain cutting effect for a given electrode while delivery current as low as possible.
- B. The RF wave form is preferably 500 KHz or higher unmodulated continuous sine wave.
- C. The delivery type can be mono-polar delivery with small area  
15 dispersive electrode for lower power applications.
- D. RF delivery control.
1. Preferably fixed power to provide cutting effect.
  2. Delivery controlled by application timer preferably fixed at about 0.6 to 1.0 seconds.

20 It can be appreciated, that angiogenesis is also stimulated by the thermal injury creating the crater, and fluid pressure entering the myocardium from the left ventricle through the endocardium by way of the crater. Hemorrhaging of the

subendocardial vasculature may also occur in response to adjacent tissue ruptures or ablation.

Figure 15 is a front view of an elongate electrode 300 having an angled distal end 302. Disposed on the front of electrode 300 is an asymmetrical radiopaque marker 304. Marker 304 could be formed from, for example, gold or platinum. As electrode 300 is rotated 180° around its longitudinal axis, electrode 300 will appear as shown in Figure 16. Figure 16 is a fluoroscopic back side view of electrode 300 wherein marker 304 appears in mirror image to its position Figure 15.

Figure 17 is a side view of electrode 300 rotated 90° round about its longitudinal axis relative to its position in Figure 15. It can be appreciated that by providing an asymmetrical marker band, the relative rotational position of the catheter or electrode in a patient can be determined by fluoroscopy.

Figures 18 and 19 are views of the front and back, respectively of electrode 300 including an alternate marker 306 configured as an F. It can be appreciated that various asymmetrical marker configurations can be used in accordance with the present invention.

It is noted several times above that contrast media can be infused into the holes, craters, wounds, or channels formed during a PMR procedure. Normal contrast media formulations will tend to dissipate rapidly into the patient's blood stream as the patient's heart continues to beat. In order to retain the contrast media within the crater for an extended period of time, a mixture of 498 Loctite™ adhesive can be radiopaque loaded with platinum or other biocompatible

radiopaque material to a weight percentage sufficient to be visible under fluoroscopy.

In use, the catheters of the present invention can be advanced percutaneously to a chamber of a patient's heart, for example, the left ventricle.  
5 The percutaneous route for advancement will generally be by way of the femoral artery and the aorta. The electrode is then brought into close proximity with the chamber wall. The electrode is energized and repeatedly plunged into the myocardium to form a plurality of holes.

Numerous advantages of the invention covered by this document have  
10 been set forth in the foregoing description. It will be understood, however, that this disclosure is, in many respects, only illustrative. Changes may be made in details, particularly in matters of shape, size, and arrangement of parts without exceeding the scope of the invention. The inventions's scope is, of course, defined in the language in which the appended claims are expressed.

15



What is claimed is:

1. A catheter assembly, comprising:  
an elongate shaft having a proximal end and a distal end, and including a conductor;  
an electrode disposed at the distal end of the shaft and connected to the conductor, the electrode having a generally annular transverse cross-sectional shape, the annular shape defining an opening within the electrode, the electrode having a distal end;  
an insulator surrounding the conductor.
2. A catheter assembly in accordance with claim 1, wherein a stop is disposed in the opening proximally a predetermined distance from the distal end of the electrode.
3. A catheter assembly in accordance with claim 1, wherein the shaft defines a lumen in fluid communication with the opening.
4. A catheter assembly in accordance with claim 3, further comprising a needle disposed within the opening and in fluid communication with the lumen.
5. A catheter assembly in accordance with claim 1, wherein the insulator includes polyethylene.

6. A catheter assembly in accordance with claim 1, wherein the insulator includes polyimide.

7. A catheter assembly in accordance with claim 1, wherein the shaft includes a stainless steel hypotube.

8. A catheter assembly in accordance with claim 1, wherein the shaft includes a Nitinol hypotube.

9. A catheter assembly in accordance with claim 1, further comprising a radiofrequency generator connected to the conductor.

10. A catheter assembly in accordance with claim 1, wherein the annular shape is generally circular.

11. A catheter assembly in accordance with claim 1, wherein the annular shape is continuous.

12. A catheter assembly in accordance with claim 1, wherein the annular shape is discontinuous.

13. A catheter assembly in accordance with claim 12, wherein the annular shape is formed by a plurality of electrodes positioned in an array.

14. A catheter assembly in accordance with claim 1, wherein the electrode includes a plurality of distally projecting members.

15. A catheter assembly in accordance with claim 14, wherein the electrode is serrated to grab tissue.

16. A catheter assembly in accordance with claim 1, further comprising a second electrode.

17. A catheter assembly in accordance with claim 16, wherein the electrode comprises a needle.

18. A method of performing PMR, comprising the steps of:  
providing a catheter including an elongate shaft having a proximal end and a distal end, and a generally annularly shaped electrode disposed at the distal end;  
advancing the electrode to proximate the endocardium of the patient's heart;  
energizing the electrode; and  
advancing the electrode into the myocardium to wound the myocardium.

19. The method in accordance with claim 18, further comprising the step of providing a lumen through the shaft.

20. The method in accordance with claim 19, further comprising the step of delivering contrast medium to the distal end through the lumen.

21. The method in accordance with claim 19, further comprising the step of delivering a drug to the distal end through the lumen.

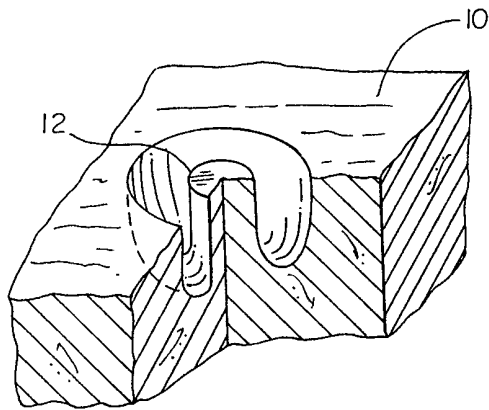
22. The method in accordance with claim 19, further comprising the step of delivering saline to the distal end through the lumen.

23. A method of performing PMR, comprising the steps of:  
forming a hole through the endocardium and into the myocardium having a width and a depth, wherein the width of the hole is greater than the depth;  
infusing a fluid into the hole.

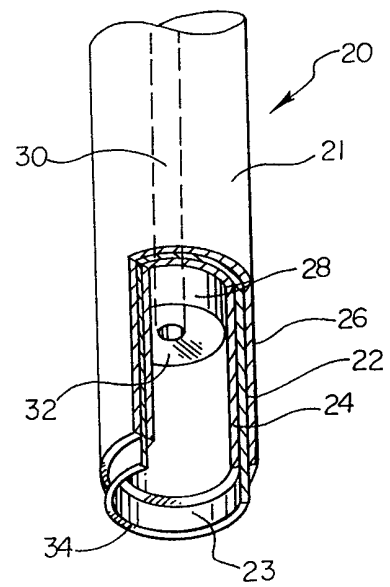
24. A catheter, comprising:  
a shaft having a distal end and a proximal end; and  
a radiopaque marker disposed proximate the distal end, the marker having

an asymmetrical shape, such that the marker appears in mirror image when viewed from opposite sides of the shaft.

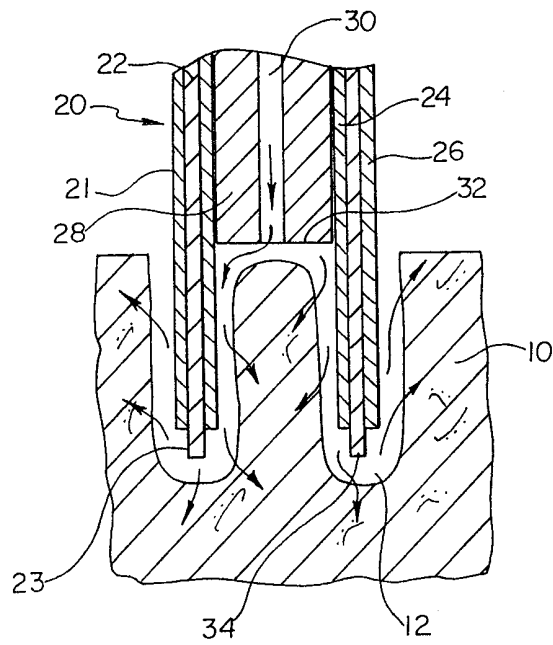
**Fig. 1**



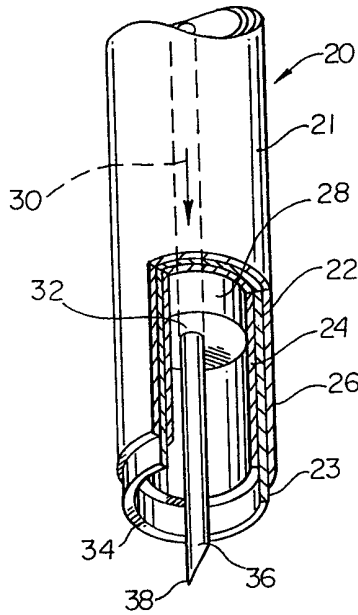
**Fig. 2**



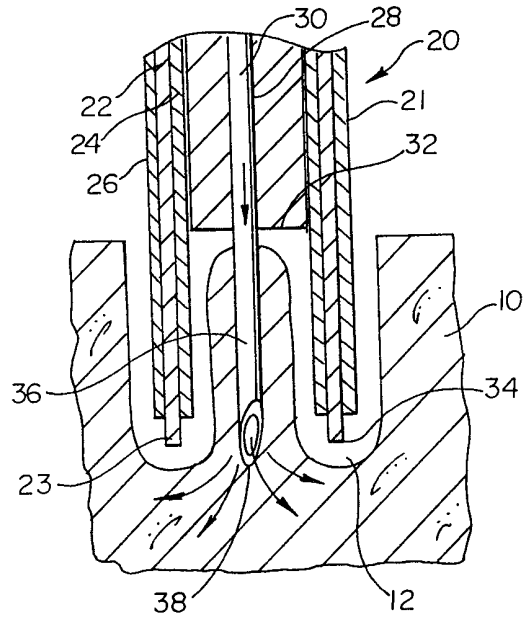
**Fig. 3**



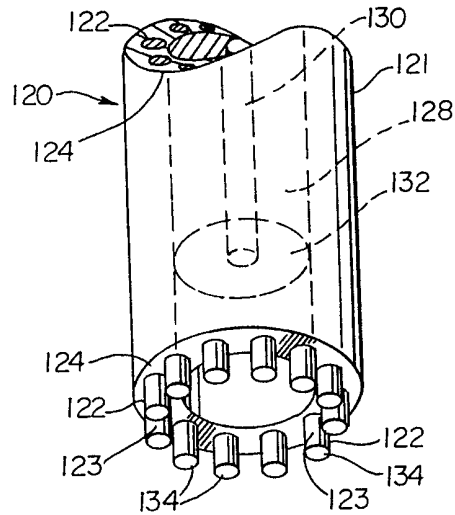
**Fig. 4**



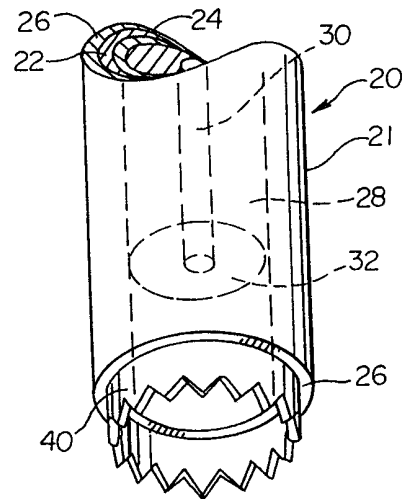
**Fig. 5**



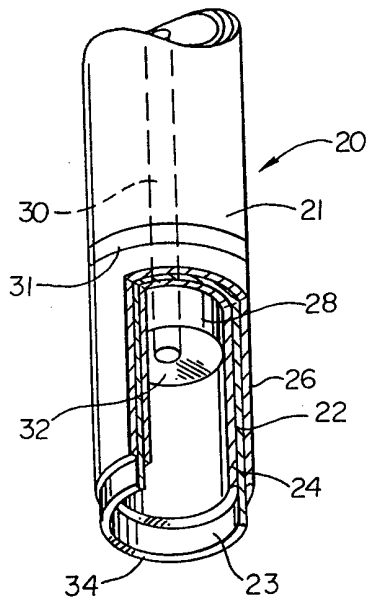
**Fig. 6**



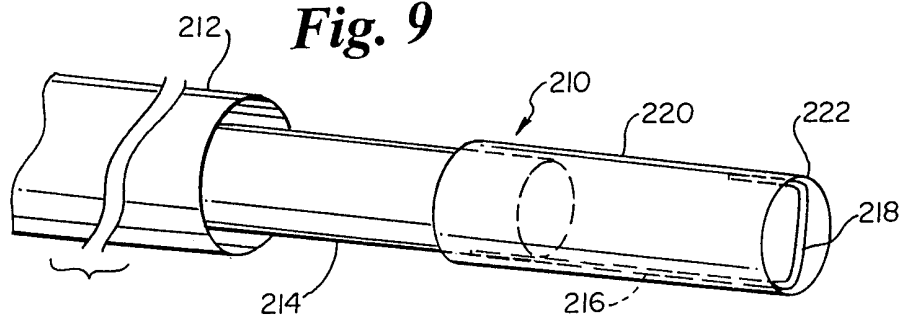
**Fig. 7**



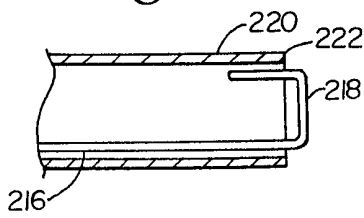
**Fig. 8**



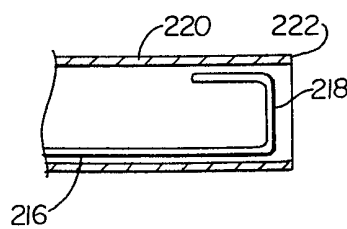
**Fig. 9**



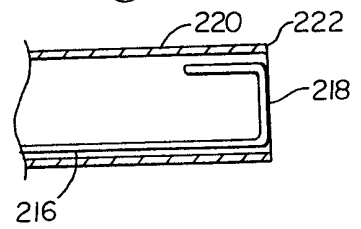
**Fig. 10**



**Fig. 11**

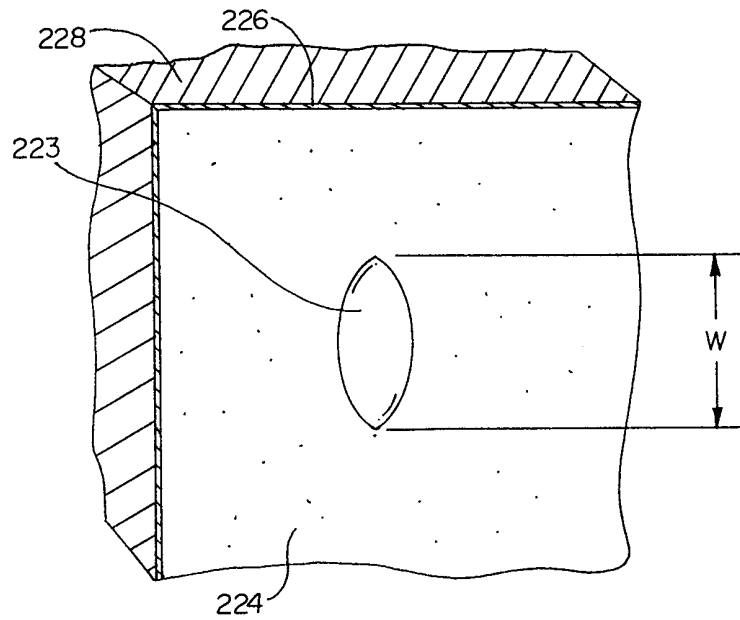


**Fig. 12**

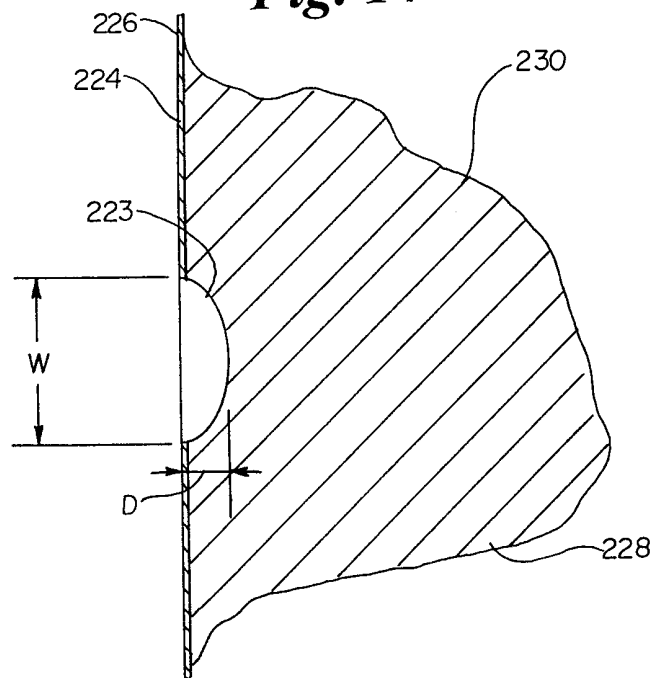




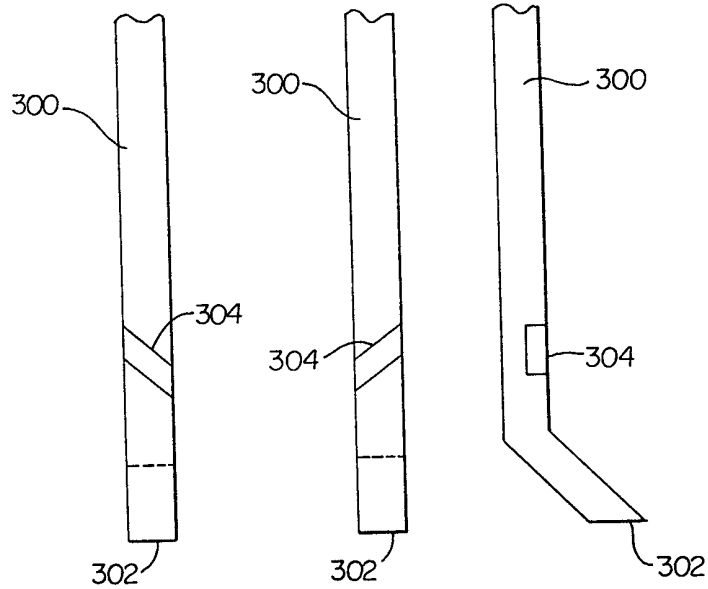
**Fig. 13**



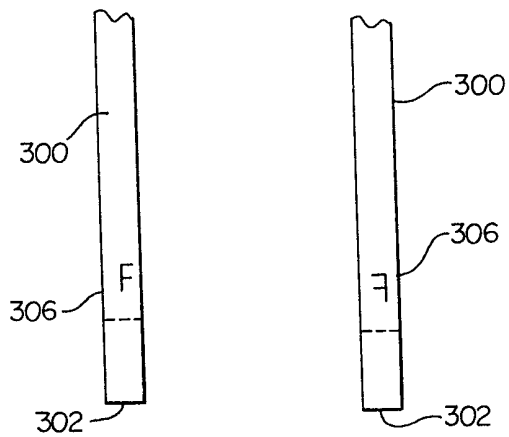
**Fig. 14**



**Fig. 15**   **Fig. 16**   **Fig. 17**



**Fig. 18**   **Fig. 19**



# INTERNATIONAL SEARCH REPORT

International Application No

PCT/US 99/04942

**A. CLASSIFICATION OF SUBJECT MATTER**

IPC 6 A61B17/39

According to International Patent Classification (IPC) or to both national classification and IPC

**B. FIELDS SEARCHED**

Minimum documentation searched (classification system followed by classification symbols)

IPC 6 A61B

Documentation searched other than minimum documentation to the extent that such documents are included in the fields searched

Electronic data base consulted during the international search (name of data base and, where practical, search terms used)

**C. DOCUMENTS CONSIDERED TO BE RELEVANT**

Category °	Citation of document, with indication, where appropriate, of the relevant passages	Relevant to claim No.
X	WO 97 18768 A (ARTHROCARE CORP) 29 May 1997	1,3, 5-14,16
Y	see page 35, line 13 - line 25; figures 14,15 see page 29, line 15 - line 20; figures 2A,2B see page 29, line 31 - line 34 see page 32, line 14 - line 20; figure 9	4,15,17
X	US 5 697 882 A (EGGERS PHILIP E ET AL) 16 December 1997 see column 20, line 19 - line 29; figures 21,22	1-3, 5-14,16
X	US 5 209 749 A (BUELNA TERRENCE J) 11 May 1993 see column 4, line 62 - column 5, line 12; figure 5	24
	--- -/--	

Further documents are listed in the continuation of box C.

Patent family members are listed in annex.

° Special categories of cited documents :

- "A" document defining the general state of the art which is not considered to be of particular relevance
- "E" earlier document but published on or after the international filing date
- "L" document which may throw doubts on priority claim(s) or which is cited to establish the publication date of another citation or other special reason (as specified)
- "O" document referring to an oral disclosure, use, exhibition or other means
- "P" document published prior to the international filing date but later than the priority date claimed

- "T" later document published after the international filing date or priority date and not in conflict with the application but cited to understand the principle or theory underlying the invention
- "X" document of particular relevance; the claimed invention cannot be considered novel or cannot be considered to involve an inventive step when the document is taken alone
- "Y" document of particular relevance; the claimed invention cannot be considered to involve an inventive step when the document is combined with one or more other such documents, such combination being obvious to a person skilled in the art.
- "&" document member of the same patent family

Date of the actual completion of the international search

15 June 1999

Date of mailing of the international search report

23/06/1999

Name and mailing address of the ISA  
European Patent Office, P.B. 5818 Patentlaan 2  
NL - 2280 HV Rijswijk  
Tel. (+31-70) 340-2040, Tx. 31 651 epo nl,  
Fax: (+31-70) 340-3016

Authorized officer

Mayer, E

# INTERNATIONAL SEARCH REPORT

Int'l. Application No PCT/US 99/04942
--

**C.(Continuation) DOCUMENTS CONSIDERED TO BE RELEVANT**

Category	Citation of document, with indication, where appropriate, of the relevant passages	Relevant to claim No.
Y	US 5 431 649 A (HOEY MICHAEL F ET AL) 11 July 1995 see column 4, line 33 - line 54; figure 2 ---	4,17
Y	EP 0 807 412 A (UNITED STATES SURGICAL CORP) 19 November 1997 see page 5, line 7 - line 10; figures 8A-8C ---	15
A	EP 0 629 382 A (VIDAMED INC) 21 December 1994 see column 12, line 19 - line 26; figures 4,5 -----	8

# INTERNATIONAL SEARCH REPORT

International application No.

PCT/US 99/ 04942

## Box I Observations where certain claims were found unsearchable (Continuation of item 1 of first sheet)

This International Search Report has not been established in respect of certain claims under Article 17(2)(a) for the following reasons:

1.  Claims Nos.: 18-23  
because they relate to subject matter not required to be searched by this Authority, namely:  
Rule 39.1(iv) PCT - Method for treatment of the human or animal body by surgery
2.  Claims Nos.:  
because they relate to parts of the International Application that do not comply with the prescribed requirements to such an extent that no meaningful International Search can be carried out, specifically:
3.  Claims Nos.:  
because they are dependent claims and are not drafted in accordance with the second and third sentences of Rule 6.4(a).

## Box II Observations where unity of invention is lacking (Continuation of item 2 of first sheet)

This International Searching Authority found multiple inventions in this international application, as follows:

1.  As all required additional search fees were timely paid by the applicant, this International Search Report covers all searchable claims.
2.  As all searchable claims could be searched without effort justifying an additional fee, this Authority did not invite payment of any additional fee.
3.  As only some of the required additional search fees were timely paid by the applicant, this International Search Report covers only those claims for which fees were paid, specifically claims Nos.:
4.  No required additional search fees were timely paid by the applicant. Consequently, this International Search Report is restricted to the invention first mentioned in the claims; it is covered by claims Nos.:

### Remark on Protest

- The additional search fees were accompanied by the applicant's protest.
- No protest accompanied the payment of additional search fees.

# INTERNATIONAL SEARCH REPORT

Information on patent family members

International Application No

PCT/US 99/04942

Patent document cited in search report	A	Publication date	Patent family member(s)	Publication date
WO 9718768	A	29-05-1997	US 5683366	A 04-11-1997
			AU 1057197	A 11-06-1997
			CA 2237795	A 29-05-1997
			EP 0865256	A 23-09-1998
			JP 11502144	T 23-02-1999
			US 5860951	A 19-01-1999
			US 5873855	A 23-02-1999
US 5697882	A	16-12-1997	US 5697281	A 16-12-1997
			US 5366443	A 22-11-1994
			AU 702687	B 04-03-1999
			AU 1054597	A 11-06-1997
			CA 2237947	A 29-05-1997
			EP 0886493	A 30-12-1998
			JP 11501555	T 09-02-1999
			WO 9718765	A 29-05-1997
			US 5843019	A 01-12-1998
			US 5871469	A 16-02-1999
			AU 6026696	A 30-12-1996
			CA 2221330	A 19-12-1996
			EP 0837647	A 29-04-1998
			JP 10510745	T 20-10-1998
			WO 9639914	A 19-12-1996
			US 5683366	A 04-11-1997
			US 5810764	A 22-09-1998
			US 5697536	A 16-12-1997
			US 5860951	A 19-01-1999
			US 5873855	A 23-02-1999
			AU 2472497	A 14-08-1997
			AU 676329	B 06-03-1997
			AU 6829694	A 12-12-1994
			CA 2162395	A 24-11-1994
			EP 0697841	A 28-02-1996
			JP 9501328	T 10-02-1997
			NZ 266678	A 19-12-1997
			WO 9426228	A 24-11-1994
			US 5681282	A 28-10-1997
			US 5888198	A 30-03-1999
US 5891095	A 06-04-1999			
AT 173903	T 15-12-1998			
AU 3335793	A 03-08-1993			
CA 2129745	A 08-07-1993			
DE 69227783	D 14-01-1999			
DE 69227783	T 20-05-1999			
EP 0624076	A 17-11-1994			
EP 0882430	A 09-12-1998			
NZ 246503	A 26-07-1996			
WO 9313816	A 22-07-1993			
US 5419767	A 30-05-1994			
US 5209749	A	11-05-1993	NONE	
US 5431649	A	11-07-1995	AU 676630	B 13-03-1997
			AU 1427995	A 21-03-1995
			CA 2168860	A 02-03-1995
			EP 0774926	A 28-05-1997
			JP 2761440	B 04-06-1998
			JP 9500810	T 28-01-1997

# INTERNATIONAL SEARCH REPORT

Information on patent family members

International Application No

PCT/US 99/04942

Patent document cited in search report	A	Publication date	Patent family member(s)	Publication date
US 5431649	A		WO 9505781 A US 5807395 A	02-03-1995 15-09-1998
<hr/>				
EP 0807412	A	19-11-1997	AU 2084597 A CA 2205155 A JP 10052433 A	20-11-1997 13-11-1997 24-02-1998
<hr/>				
EP 0629382	A	21-12-1994	US 5370675 A AT 132046 T AU 671405 B AU 2047595 A AU 657235 B AU 4999893 A BR 9306893 A CA 2121032 A,C CA 2226484 A DE 4305663 A DE 69301143 D EP 0611314 A EP 0893101 A ES 2084510 T FI 950584 A FR 2694700 A GB 2269538 A,B IL 104647 A JP 7503645 T MX 9304905 A NZ 255687 A US 5385544 A US 5421819 A US 5435805 A WO 9404220 A US 5409453 A US 5470308 A US 5366490 A US 5556377 A US 5720718 A US 5542915 A US 5470309 A US 5554110 A US 5549644 A US 5484400 A US 5630794 A US 5514131 A US 5672153 A US 5720719 A US 5531676 A US 5536240 A US 5542916 A US 5599294 A US 5540655 A US 5667488 A US 5531677 A US 5582589 A US 5591125 A US 5749846 A	06-12-1994 15-01-1996 22-08-1996 10-08-1995 02-03-1995 15-03-1994 08-12-1998 03-03-1994 03-03-1994 17-02-1994 08-02-1996 24-08-1994 27-01-1999 01-05-1996 04-04-1995 18-02-1994 16-02-1994 31-12-1995 20-04-1995 29-04-1994 20-12-1994 31-01-1995 06-06-1995 25-07-1995 03-03-1994 25-04-1995 28-11-1995 22-11-1994 17-09-1996 24-02-1998 06-08-1996 28-11-1995 10-09-1996 27-08-1996 16-01-1996 20-05-1997 07-05-1996 30-09-1997 24-02-1998 02-07-1996 16-07-1996 06-08-1996 04-02-1997 30-07-1996 16-09-1997 02-07-1996 10-12-1996 07-01-1997 12-05-1998