

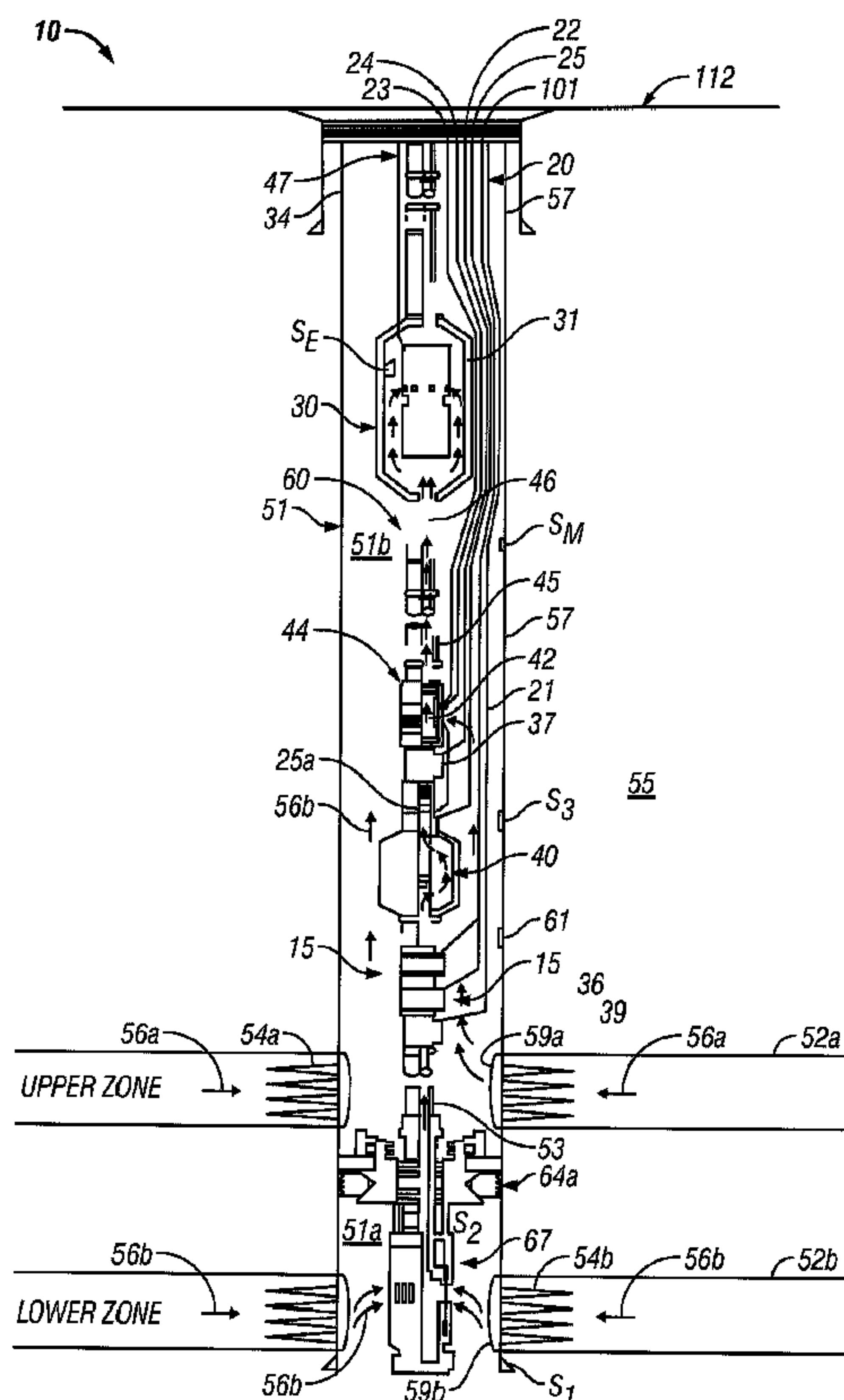

(86) Date de dépôt PCT/PCT Filing Date: 2008/04/18
 (87) Date publication PCT/PCT Publication Date: 2009/01/15
 (45) Date de délivrance/Issue Date: 2012/12/11
 (85) Entrée phase nationale/National Entry: 2009/10/15
 (86) N° demande PCT/PCT Application No.: US 2008/060797
 (87) N° publication PCT/PCT Publication No.: 2009/009196
 (30) Priorité/Priority: 2007/04/19 (US11/737,313)

(51) Cl.Int./Int.Cl. *E21B 43/12* (2006.01)
 (72) Inventeurs/Inventors:
 THIGPEN, BRIAN L., US;
 VACHON, GUY P., US;
 YERIAZARIAN, GARABED, US;
 LEE, JAEDONG, US;
 CHOK, CHEE M., US;
 SANN, CLARK, US;
 LIU, XIN, US
 (73) Propriétaire/Owner:
 BAKER HUGHES INCORPORATED, US
 (74) Agent: SIM & MCBURNEY

(54) Titre : SYSTEME ET PROCEDE PERMETTANT DE SURVEILLER L'ETAT PHYSIQUE D'UN EQUIPEMENT DE PUIXS DE PRODUCTION ET DE REGULER LA PRODUCTION DU PUIXS DE PRODUCTION
 (54) Title: SYSTEM AND METHOD FOR MONITORING PHYSICAL CONDITION OF PRODUCTION WELL EQUIPMENT AND CONTROLLING WELL PRODUCTION



(57) Abrégé/Abstract:

A system and method for producing fluid from a completed well is provided wherein the method in one aspect includes determining a first setting of at least one first device under use for producing the fluid from the well; selecting a first set of input parameters that

(57) **Abrégé(suite)/Abstract(continued):**

includes at least one parameter relating to health of at least one second device and a plurality of parameters selected from a group consisting of information relating to flow rate, pressure, temperature, presence of a selected chemical, water content, sand content, and chemical injection rate; and using the selected first set of parameters as an input to a computer model, determining a second setting for the at least one first device that will provide at least one of an increased life of at least one second device and enhanced flow rate for the fluid from the completed well.

(12) INTERNATIONAL APPLICATION PUBLISHED UNDER THE PATENT COOPERATION TREATY (PCT)

(19) World Intellectual Property Organization
International Bureau(43) International Publication Date
15 January 2009 (15.01.2009)

PCT

(10) International Publication Number
WO 2009/009196 A3(51) International Patent Classification:
E21B 43/12 (2006.01)

(21) International Application Number:

PCT/US2008/060797

(22) International Filing Date: 18 April 2008 (18.04.2008)

(25) Filing Language: English

(26) Publication Language: English

(30) Priority Data:

11/737,313 19 April 2007 (19.04.2007) US

(71) Applicant (for all designated States except US): **BAKER HUGHES INCORPORATED** [US/US]; 2929 Allen Parkway, Suite 2100, Houston, TX 77019-2118 (US).

(72) Inventors; and

(75) Inventors/Applicants (for US only): **THIGPEN, Brian, L.** [US/US]; 922 Arlington Street, Houston, TX 77008 (US). **VACHON, Guy, P.** [US/US]; 1517 Haddon, Houston, TX 77006 (US). **YERIAZARIAN, Garabed** [US/US]; 22311 Wildwood Grove Drive, Katy, TX 77450 (US). **LEE, Jaedong** [KR/US]; 22918 Roberts Run Lane,Katy, TX 77494 (US). **CHOK, Chee, M.** [MY/US]; 4123 Swarthmore, Houston, TX 77005 (US). **SANN, Clark** [US/US]; 6202 Conlan Bay Drive, Houston, TX 77041 (US). **LIU, Xin** [US/US]; 23311 Angel Gate Court, Katy, TX 77494 (US).(74) Agent: **HENDRYX, Thomas, N.**; Baker Hughes Incorporated, P.O. Box 4740, Houston, TX 77027-4740 (US).

(81) Designated States (unless otherwise indicated, for every kind of national protection available): AE, AG, AL, AM, AO, AT, AU, AZ, BA, BB, BG, BH, BR, BW, BY, BZ, CA, CH, CN, CO, CR, CU, CZ, DE, DK, DM, DO, DZ, EC, EE, EG, ES, FI, GB, GD, GE, GH, GM, GT, HN, HR, HU, ID, IL, IN, IS, JP, KE, KG, KM, KN, KP, KR, KZ, LA, LC, LK, LR, LS, LT, LU, LY, MA, MD, ME, MG, MK, MN, MW, MX, MY, MZ, NA, NG, NI, NO, NZ, OM, PG, PH, PL, PT, RO, RS, RU, SC, SD, SE, SG, SK, SL, SM, SV, SY, TJ, TM, TN, TR, TT, TZ, UA, UG, US, UZ, VC, VN, ZA, ZM, ZW.

(84) Designated States (unless otherwise indicated, for every kind of regional protection available): ARIPO (BW, GH,

[Continued on next page]

(54) Title: SYSTEM AND METHOD FOR MONITORING PHYSICAL CONDITION OF PRODUCTION WELL EQUIPMENT AND CONTROLLING WELL PRODUCTION

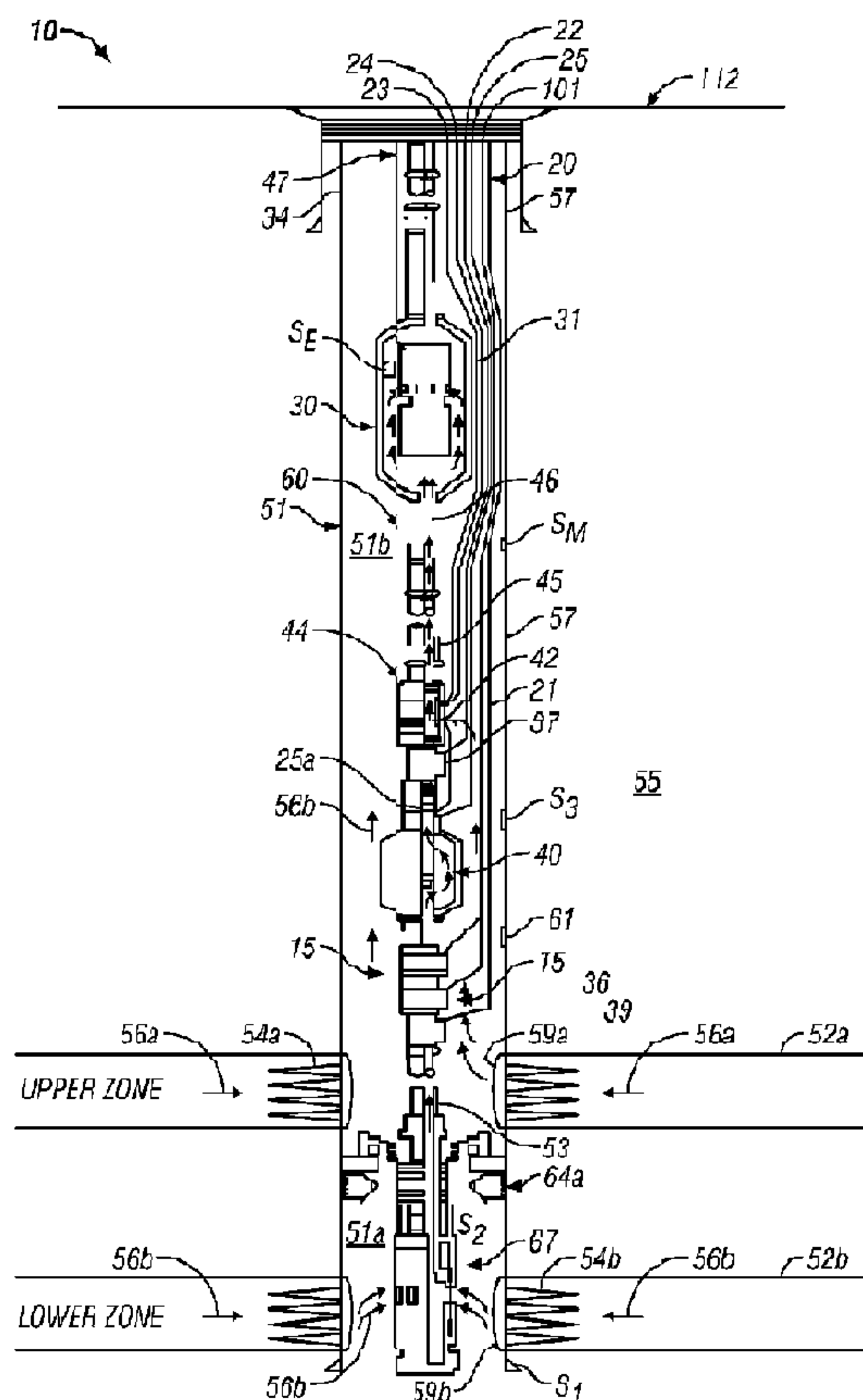

FIG. 1A

(57) Abstract: A system and method for producing fluid from a completed well is provided wherein the method in one aspect includes determining a first setting of at least one first device under use for producing the fluid from the well; selecting a first set of input parameters that includes at least one parameter relating to health of at least one second device and a plurality of parameters selected from a group consisting of information relating to flow rate, pressure, temperature, presence of a selected chemical, water content, sand content, and chemical injection rate; and using the selected first set of parameters as an input to a computer model, determining a second setting for the at least one first device that will provide at least one of an increased life of at least one second device and enhanced flow rate for the fluid from the completed well.

WO 2009/009196 A3

WO 2009/009196 A3



GM, KE, LS, MW, MZ, NA, SD, SL, SZ, TZ, UG, ZM, ZW), Eurasian (AM, AZ, BY, KG, KZ, MD, RU, TJ, TM), European (AT, BE, BG, CH, CY, CZ, DE, DK, EE, ES, FI, FR, GB, GR, HR, HU, IE, IS, IT, LT, LU, LV, MC, MT, NL, NO, PL, PT, RO, SE, SI, SK, TR), OAPI (BF, BJ, CF, CG, CI, CM, GA, GN, GQ, GW, ML, MR, NE, SN, TD, TG).

Published:

- *with international search report*
- *before the expiration of the time limit for amending the claims and to be republished in the event of receipt of amendments*

(88) Date of publication of the international search report:

19 March 2009

SYSTEM AND METHOD FOR MONITORING PHYSICAL CONDITION OF PRODUCTION WELL EQUIPMENT AND CONTROLLING WELL PRODUCTION

Inventors: Brian L. Thigpen; Guy P. Vachon; Garabed Yeriazarian;
Jaedong Lee; Chee M. Chok; Clark Sann; Xin Liu

BACKGROUND OF THE DISCLOSURE

1. Field of the Disclosure

[0001] This disclosure relates generally to monitoring of production well equipment for enhanced production of hydrocarbons.

2. Background of the Art

[0002] Wellbores are drilled in subsurface formations for the production of hydrocarbons (oil and gas). A variety of wells are formed, including vertical wells, inclined wells, horizontal wells and multi-lateral wells. Some such wells penetrate multiple production zones and may traverse substantial distance in the subsurface formations. Wells are typically completed by cementing jointed metallic pipes (referred to as the casing) in the well, with the cement forming a bond between the formation and the casing that lines the well. Complex wells may include multiple remote control devices such as chokes, valve, artificial lift devices, such as an electrical submersible pump (ESP); a variety of sensors, such as pressure sensor, temperature and flow sensors; hydraulic lines that inject chemicals at various depths in the well or operate downhole devices; and electrical devices, circuits and processors that process data and signals downhole and establish communication with surface and other downhole equipment.

[0003] Downhole well conditions, such as high pressure differential between the formation and the well, high formation fluid flow rate and the condition of the formation rock, such as high permeability can cause excessive production of sand, cause formation of scale, corrosion, hydrate, paraffin and asphaltene, each of which can erode downhole equipment, block fluid flow paths in the downhole equipment and the tubing that carries the fluids to the surface, degrade performance of the ESP,

etc. Cracks in the cement bond can allow undesirable fluids from adjoining formations to penetrate into the well. For efficient production of fluids from the formation to the surface, it is desirable to monitor the wellbore condition and the physical condition or health of various equipment, take actions that may provide enhanced or optimal production of hydrocarbons from the well.

SUMMARY OF THE DISCLOSURE

[0004] In one aspect there is provided a method of producing fluid from a well, comprising:

determining a first setting of at least one first downhole device that is under use for producing the fluid from the well;

selecting a set of parameters that includes at least one parameter relating to health of at least one second downhole device and a plurality of parameters selected from a group comprising flow rate, pressure, temperature, presence of a selected chemical, water content, sand content, and chemical injection rate; and

using the selected set of parameters as an input to a computer model to determine a second setting for the at least one first downhole device that will provide an increased life of the at least one second downhole device and enhanced flow rate for the fluid from the completed well; and

setting the at least one first downhole device to the second setting.

[0005] In another aspect there is provided a computer system for controlling an operation of an electrical submersible pump placed in a well for producing a fluid from the well, comprising:

a database that stores information corresponding to one of:

an operating envelope for the electrical submersible pump that is based on a relationship among fluid flow rate, frequency and head over the electrical submersible pump; and

a maximum flow rate for the electrical submersible pump corresponding to the frequency and head; and

a processor that utilizes at least one measured operating parameter of the electrical submersible pump and the information stored in the database and determines a setting for at least the electrical submersible pump and another downhole device that will cause the electrical submersible pump to operate according to one of: within the envelope, and proximate the maximum flow rate.

[0006] In another aspect there is provided a method of controlling operation of an electrical submersible pump in a well that is producing fluids, comprising:

determining an operating envelope for the electrical submersible pump that is based on a relationship among fluid flow rate, frequency and head over the electrical submersible pump and includes a maximum flow rate for the electrical submersible pump corresponding to the frequency and head;

measuring an operating parameter of the electrical submersible pump using a sensor in the well; and

altering an operation of one of the electrical submersible pump and a downhole device to operate the electrical submersible pump according to one of: within the operating envelope; and proximate the maximum flow rate.

[0007] In another aspect there is provided a computer-readable medium that has embedded therein a computer program that is accessible to a processor for executing instructions contained in the computer program, the computer program comprising:

instructions to determine a first setting of at least one first downhole device while in use for producing the fluid from the well;

instructions to select a first set of input parameters that includes at least one parameter relating to health of at least one second downhole device and a plurality of parameters selected from a group consisting of: information relating to flow rate, pressure, temperature, presence of a selected chemical, water content, sand content, and chemical injection rate;

instructions to use the selected first set of parameters as an input to determine a second setting for at least one first downhole device that will provide at least one of an increased life of the at least one second downhole device and enhanced flow rate for the fluid from the completed well; and

instructions to send signals to operate the well corresponding to the second setting of the at least one first downhole device.

[0008] Examples of the more important features of a system and method for monitoring a physical condition of a production well equipment and controlling well production have been summarized rather broadly in order that the detailed description thereof that follows may be better understood, and in order that the contributions to the art may be appreciated. There are, of course, additional features that will be described hereinafter and which will form the subject of the claims.

BRIEF DESCRIPTION OF THE DRAWINGS

[0009] For a detailed understanding of the system and methods for monitoring and controlling production wells described and claimed herein, reference should be made to the accompanying drawings and the following detailed description of the drawings wherein like elements generally have been given like numerals, and wherein:

FIGS. 1A and **1B** collectively show a schematic diagram of a production well system for producing fluid from multiple production zones according to one possible embodiment;

FIG. 2 is an exemplary functional diagram of a control system that may be utilized for a well system, including the system shown in **FIGS. 1A** and **1B**, to take various measurements relating to the well, determine desired actions that may be taken to improve production from the well, automatically take one or more such actions, predict the effects of such actions and monitor the well performance after taking such actions; and

FIG. 3 shows an exemplary two-dimensional operating envelope for an electrical submersible pump that may be utilized in performing one or more methods described herein.

DETAILED DESCRIPTION OF THE DRAWINGS

[00010] FIGS. 1A and 1B collectively show a schematic diagram of a production well system 10 according to one embodiment of the disclosure. FIG. 1A shows a production well 50 that is configured using exemplary equipment, devices and sensors that may be utilized to implement the concepts and methods described herein. FIG. 1B shows exemplary surface equipment, devices, sensors, controllers, computer programs, models and algorithms that may be utilized to monitor and maintain the health of the equipment in the well and take actions that may provide enhanced production from the well over the life of the well 50. In one aspect, the system 10 is configured to periodically or continuously utilize measurements from various sensors and other data to determine the condition of the various equipment in the system 10, including, but not limited to, the conditions of chokes, valves, ESP, sand screens, casing, cement bond, and tubing. In another aspect, the system 10 may estimate or predict the flow rate changes due to one or more changes in the health of one or more devices. In another aspect, the system 10 may determine the actions that may be taken to reduce, prevent or minimize further deterioration of the equipment.

[00011] In another aspect, the system 10 may be configured to determine the desired actions that may be taken to enhance, optimize or maximize production from the well 50 based on the conditions of the downhole and surface equipment that meet selected criteria. In one aspect, the system may use a nodal analysis, neural network or other algorithms to determine the desired actions that will enhance production or provide a higher net present value for the well. In another aspect, system 10 may be configured to send desired messages and alarms to an operator and/or to other locations relating to the condition of the well and the adjustments to be made or actions to be taken relating to the various operations of the well 50 to do one or more of the following: operate the ESP within selected bounds; adjust one or more parameters to enhance, optimize or maximize the production of hydrocarbons from the well, based on the interaction of various wellbore parameters; mitigate or eliminate negative effects of the potential or actual occurrence of a detrimental condition, such as build up of a chemical, such as scale, corrosion, hydrate and asphaltene; predict the failure of a particular equipment, such as casing, cement bond, valve or choke and terminate production from one or more affected zones prior to the occurrence of the failure of

the particular equipment, etc. In another aspect, the system may compute net present value based on the current operation of the well and the production after taking one or more actions described herein.

[00012] In another aspect, system **10** may be configured to monitor actions taken (if any) by the operator in response to the messages sent by the system; update any actions to be taken after any adjustments have been made by the operator; make selected adjustments when the operator fails to take certain actions; automatically control and monitor any one or more of the devices or equipment in the system **10**; and provide status reports to the operator and other locations, including one or more remote locations. In another aspect, the system **10** may be configured to establish a two-way communication with one or more remote locations and/or controllers via one or more suitable data communication links, including the Internet, wired or wireless links and using one or more suitable protocols, including the Internet protocols.

[00013] FIG. 1A shows a well **50** formed in a formation **55** that produces formation fluids **56a** and **56b** from two exemplary production zones **52a** (upper production zone) and **52b** (lower production zone) respectively. The well **50** is shown lined with a casing **57** that has perforations **54a** adjacent the upper production zone **52a** and perforations **54b** adjacent the lower production zone **52b**. A packer **64**, which may be a retrievable packer, positioned above or uphole of the lower production zone perforations **54a** isolates the lower production zone **52b** from the upper production zone **52a**. A screen **59b** adjacent the perforations **54b** the well **50** may be installed to prevent or inhibit solids, such as sand, from entering into the wellbore from the lower production zone **54b**. Similarly, a screen **59a** may be used adjacent the upper production zone perforations **59a** to prevent or inhibit solids from entering into the well **50** from the upper production zone **52a**.

[00014] The formation fluid **56b** from the lower production zone **52b** enters the annulus **51a** of the well **50** through the perforations **54a** and into a tubing **53** via a flow control valve **67**. The flow control valve **67** may be a remotely controlled sliding sleeve valve or any other suitable valve or choke that can regulate the flow of the fluid from the annulus **51a** into the production tubing **53**. An adjustable choke **40** in the tubing **53** may be used to regulate the fluid flow from the lower production zone **52b** to the surface **112**. The formation fluid **56a** from the upper production zone

52a enters the annulus **51b** (the annulus portion above the packer **64a**) via perforations **54a**. The formation fluid **56a** enters production tubing or line **45** via inlets **42**. An adjustable valve or choke **44** associated with the line **45** regulates the fluid flow into the line **45** and may be used to adjust flow of the fluid to the surface **112**. Each valve, choke and other such device in the well may be operated electrically, hydraulically, mechanically and/or pneumatically from the surface. The fluid from the upper production zone **52a** and the lower production zone **52b** enter the line **46**.

[00015] In cases where the formation pressure is not sufficient to push the fluid **56a** and/or fluid **56b** to the surface, an artificial lift mechanism, such as an electrical submersible pump (ESP) or a gas lift system may be utilized to lift the fluids from the well to the surface **112**. In the system **10**, an ESP **30** in a manifold **31** is shown as the artificial lift mechanism, which receives the formation fluids **56a** and **56b** and pumps such fluids via tubing **47** to the surface **112**. A cable **34** provides power to the ESP **30** from a surface power source **132** (FIG. 1B) that is controlled by an ESP control unit **130**. The cable **134** also may include two-way data communication links **134a** and **134b**, which may include one or more electrical conductors or fiber optic links to provide a two-way signals and data link between the ESP **30**, ESP sensors S_E and the ESP control unit **130**. The ESP control unit **130**, in one aspect, controls the operation of the ESP **30**. The ESP control unit **130** may be a computer-based system that may include a processor, such as a microprocessor, memory and programs useful for analyzing and controlling the operations of the ESP **30**. In one aspect, the controller **130** receives signals from sensors S_E (FIG. 1A) relating to the actual pump frequency, flow rate through the ESP, fluid pressure and temperature associated with the ESP **30** and may receive measurements or information relating to certain chemical properties, such as corrosion, scaling, asphaltenes, etc. and response thereto or other determinations control the operation of the ESP **30**. In one aspect, the ESP control unit **130** may be configured to alter the ESP pump speed by sending control signals **134a** in response to the data received via link **134b** or instructions received from another controller. The ESP control unit **130** may also shut down power to the ESP via the power line **134**. In another aspect, ESP control unit **130** may provide the ESP related data and information (frequency, temperature, pressure, chemical sensor

information, etc.) to the central controller **150**, which in turn may provide control or command signals to the ESP control unit **130** to effect selected operations of the ESP **30**.

[00016] A variety of hydraulic, electrical and data communication lines (collectively designated by numeral **20** (**FIG. 1A**)) are run inside the well **50** to operate the various devices in the well **50** and to obtain measurements and other data from the various sensors in the well **50**. As an example, a tubing **21** may supply or inject a particular chemical from the surface into the fluid **56b** via a mandrel **36**. Similarly, a tubing **22** may supply or inject a particular chemical to the fluid **56a** in the production tubing via a mandrel **37**. Lines **23** and **24** may operate the chokes **40** and **42** and may be used to operate any other device, such as the valve **67**. Line **25** may provide electrical power to certain devices downhole from a suitable surface power source. Two-way data communication links between sensors and/or their associated electronic circuits (generally denoted by numeral **25a** and located at any one or more suitable downhole locations) may be established by any desired method including but not limited to via wires, optical fibers, acoustic telemetry using a fluid line; electromagnetic telemetry etc.

[00017] In one aspect, a variety of other sensors are placed at suitable locations in the well **50** to provide measurements or information relating to a number of downhole parameters of interest. In one aspect, one or more gauge or sensor carriers, such as a carrier **15**, may be placed in the production tubing to house any number of suitable sensors. The carrier **15** may include one or more temperature sensors, pressure sensors, flow measurement sensors, resistivity sensors, sensors that provide information about density, viscosity, water content or water cut, and chemical sensors that provide information about scale, corrosion, asphaltenes, hydrates etc. Density sensors may be fluid density measurements for fluid from each production zone and that of the combined fluid from two or more production zones. The resistivity sensor or another suitable sensor may provide measurements relating to the water content or the water cut of the fluid mixture received from each production zones. Other sensors may be used to estimate the oil/water ratio and gas/oil ratio for each production zone and for the combined fluid. The temperature, pressure and flow sensors provide measurements for the pressure, temperature and flow rate of the fluid in the line **53**.

Additional gauge carriers may be used to obtain pressure, temperature and flow measurements, water content relating to the formation fluid received from the upper production zone **52a**. Additional downhole sensors may be used at other desired locations to provide measurements relating to chemical characteristics of the downhole fluid, such as paraffins, hydrates, sulfides, scale, asphaltene, emulsion, etc. Additionally, sensors S_1 - S_m may be permanently installed in the wellbore **50** to provide acoustic or seismic or microseismic measurements, formation pressure and temperature measurements, resistivity measurements and measurements relating to the properties of the casing **51** and formation **55**. Such sensors may be installed in the casing **57** or between the casing **57** and the formation **55**. Additionally, the screen **59a** and/or screen **59b** may be coated with tracers that are released due to the presence of water, which tracers may be detected at the surface or downhole to determine or predict the occurrence of water breakthrough. Sensors also may be provided at the surface, such as a sensor for measuring the water content in the received fluid, total flow rate for the received fluid, fluid pressure at the wellhead, temperature, etc. Other devices may be used to estimate the production of sand for each zone.

[00018] In general, sufficient sensors may be suitably placed in the well **50** to obtain measurements relating to each desired parameter of interest. Such sensors may include, but are not limited to: sensors for measuring pressures corresponding to each production zone, pressure along a selected length of the wellbore, pressure inside a pipe carrying the formation fluid, pressure in the annulus; sensors for measuring temperatures at selected places along the wellbore; sensors for measuring fluid flow rates corresponding to each of the production zones, total flow rate, flow through the ESP; sensors for measuring ESP temperature and pressure; chemical sensors for providing signals corresponding to build up of chemical, such as hydrates, corrosion, scale and asphaltene; acoustic or seismic sensors that measure signals generated at the surface or in offset wells and signals due to the fluid travel from injection wells or due to a fracturing operation; optical sensors for measuring chemical compositions and other parameters; sensors for measuring various characteristics of the formations surrounding the well, such as resistivity, porosity, permeability, fluid density, etc. The sensors may be installed in the tubing in the well or in any device or may be permanently installed in the well, for example, in the wellbore casing, in the wellbore

wall or between the casing and the wall. The sensors may be of any suitable type, including electrical sensors, mechanical sensors, piezoelectric sensors, fiber optic sensors, optical sensors, etc. The signals from the downhole sensors may be partially or fully processed downhole (such as by a microprocessor and associated electronic circuitry that is in signal or data communication with the downhole sensors and devices) and then communicated to the surface controller **150** via a signal/data link, such as link **101**. The signals from downhole sensors may also be sent directly to the controller **150**.

[00019] Referring back to **FIG. 1B**, the system **10** is further shown to include a chemical injection unit **120** at the surface for supplying additives **113a** into the well **50** and additives **113b** to the surface fluid treatment unit **170**. The desired additives **113a** from a source **116a** (such as a storage tank) thereof may be injected into the wellbore **50** via injection lines **21** and **22** by a suitable pump **118**, such as a positive displacement pump. The additives **113a** flow through the lines **21** and **22** and discharge into the manifolds **30** and **37**. The same or different injection lines may be used to supply additives to different production zones. Separate injection lines, such as lines **21** and **22**, allow independent injection of different additives at different well depths. In such a case, different additive sources and pumps are employed to store and to pump the desired additives. Additives may also be injected into a surface pipeline, such as line **176** or the surface treatment and processing facility such as unit **170**.

[00020] A suitable flow meter **120**, which may be a high-precision, low-flow, flow meter (such as gear-type meter or a nutating meter), measures the flow rate through lines **21** and **22**, and provides signals representative of the corresponding flow rates. The pump **118** is operated by a suitable device **122**, such as a motor or a compressed air device. The pump stroke and/or the pump speed may be controlled by the controller **80** via a driver circuit **92** and control line **122a**. The controller **80** may control the pump **118** by utilizing programs stored in a memory **91** associated with the controller **80** and/or instructions provided to the controller **80** from the central controller or processor **150** or a remote controller **185**. The central controller **150** communicates with the controller **80** via a suitable two-way link **85** that may be a wired, optical fiber or wireless connection and using any one or more suitable

protocols. The controller **80** may include a processor **92**, resident memory **91**, for storing programs, tables, data and models. The processor **92**, utilizing signals from the flow measuring device received via line **121** and programs stored in the memory **91** determines the flow rate of each of the additives and displays such flow rates on the display **81**. A sensor **94** may provide information about one or more parameters of the pump, such as the pump speed, stroke length, etc. For example, the pump speed or stroke length may be increased when the measured amount of the additive injected is less than the desired amount and decreased when the injected amount is greater than the desired amount. The controller **80** also includes circuits and programs, generally designated by numeral **92**, to provide interface with the onsite display **81** and to perform other desired functions. A level sensor **94a** provides information about the remaining contents of the source **116**. Alternatively, central controller **150** may send commands to controller **80** relating to the additive injection or may perform the functions of the controller **80**. While **FIGS. 1A-1B** illustrate one production well, it should be understood that an oil field can include a plurality of production wells and also a variety of wells, such as offset wells, injection wells, test wells, etc. The tools and devices shown in the figures may be utilized in any number of such wells and can be configured to work cooperatively or independently.

[00021] FIG. 2 shows a functional diagram of an exemplary production well system **200** that may be utilized to monitor the health of various devices in the system **10** (**FIGS. 1A** and **1B**) and in response thereto control the operation of one or more devices in the system **10** so as to increase the life or one or more devices in the system and/or enhance, optimize, or maximize production from the well and/or the reservoir. System **200** includes a central control unit or controller **150** that includes one or more processors, such as a processor **152**, suitable memory devices **154** and associated circuitry **156** that are configured to perform various functions and methods described herein. The system **200** includes a database **230** stored in a suitable computer-readable medium that is accessible to the processors **152**. The database **230** may include: (i) well completion data and information, such as types and locations of sensors in the well, sensor parameters, types of devices and their parameters, such as choke type and sizes, choke positions, valve type and sizes, valve positions, casing wall thickness, etc.; (ii) formation parameters, such as rock type for various formation layers,

porosity, permeability, mobility, resistivity, and depth of each formation layer and production zone; (iii) sand screen parameters; (iv) tracer information; (v) ESP parameters, such as horsepower, frequency range, operating pressure range, maximum pressure differential across the ESP, operating temperature range, and an operating envelope, such as envelope **370** as shown in **FIG. 3**; (vi) historical well performance data, including production rates over time for each production zone, pressure and temperature values over time for each production zone; (vii) current and prior choke and valve settings; (viii) intervention and remedial work information; (ix) sand and water content corresponding to each production zone over time; (x) initial seismic data (two or three dimensional maps) and updated seismic data (four D seismic maps); (xi) waterfront monitoring data; (xii) microseismic data that may relate to seismic activity due to fluid front movement, fracturing, etc.; (xiii) casing inspection logs, such as obtained by using acoustic or electrical logging tools that provide an image of the casing showing pits, gauges, holes, cracks in the casing; and (xiv) any other data that may be useful for determining the health of the downhole devices, determining the desired actions and for monitoring the effects of taking the actions so as to recover the hydrocarbons at an enhanced or optimized rate from the well **50**.

[00022] During the life of a well, one or more tests, collectively designated by numeral **224**, are typically performed to estimate the health of various well elements and various parameters of the production zones and the formation layers surrounding the well. Such tests may include, but are not limited to: casing inspection tests using electrical or acoustic logs for determining the condition of the casing and formation properties; well shut-in tests that may include pressure build-up or pressure transients, temperature and flow tests; seismic tests that may use a source at the surface and seismic sensors in the well to determine water front and bed boundary conditions; microseismic measurement responsive to a downhole operation, such as a fracturing operation or a water injection operation; fluid front monitoring tests; secondary recovery tests, etc. All such test data **224** may be stored in a memory and provided to the processor **152** for monitoring the production from well **50**, performing analysis relating to determining the health of the various equipment and for enhancing, optimizing or maximizing production from the well **50** and the reservoir.

[00023] Additionally, the processor **152** of system **200** may periodically or continually access the downhole sensor measurement data **222**, surface measurement data **226** and any other desired information or measurements **228**. The downhole sensor measurements **222** includes, but are not limited to: information relating to water content or water cut; resistivity; density; viscosity; sand content; flow rates; pressure; temperature; chemical characteristics or compositions of fluids, including the presence, amount and location of corrosion, scale, paraffin, hydrate and asphaltene; gravity; inclination; electrical and electro-magnetic measurements; oil/gas and oil/water ratios; and choke and valve positions. The surface measurements **226** include, but are not limited to: flow rates; pressures; choke and valve positions; ESP parameters; water content determined at the surface; chemical injection rates and locations; tracer detection information; etc.

[00024] The system **200** also includes programs, models and algorithms **232** embedded in one or more computer-readable media that are accessible to the processor **152** to execute instructions contained in the programs. The processor **152** may utilize one or more programs, models and algorithms to perform the various functions and methods described herein. In one aspect, the programs/models/algorithms **232** may be in the form of a well performance analyzer (WPA) that is used by the processor **152** to analyze some or all of the measurement data **222**, **226**, test data **224**, information in the database **230** and any other desired information made available to the processor to estimate or predict one or more parameters of the well operation.

[00025] The condition of a well can change due to a variety of factors, such as: a zone starts to produce undesirable amounts of water and/or sand; presence of chemicals, such as scale, corrosion, paraffin, hydrate and asphaltene; deterioration of the casing, such as presence of pits, cracks and gauges; breakdown of downhole equipment, including sand screen, downhole valves, chokes, ESP and other equipment; clogging of pipes in the well; etc. Excessive sand production can damage and/or clog sand screens, chokes, valves, and ESP and can clog pipes that carry the fluid to the surface. Changes in the downhole conditions, such as pressure, temperature and flow rates, water cut, etc. can accelerate the formation of scale, corrosion, hydrate, paraffin and asphaltene, each of which can affect the downhole

devices. Some of these changes may affect more than one device in the well. For example, corrosion may affect several metallic devices, scale may make moving a valve or choke position difficult; asphaltene may affect the operation of the pipes and ESP, increase in water content or excessive pressure drop between the formation and the well may cause asphaltene to flocculate, which in turn may affect the operation of several other devices; cracks in cement bond may allow water from other formations to penetrate into perforations and then into the well, which in turn may increase the water-cut to undesirable level, which may start to cause the other problems noted above. Therefore in many situations, a change in one or more parameters may necessitate taking one or more actions to mitigate the potential effects of such change. Also, it is desirable to predict or estimate when and the extent of changes and take actions to reduce or eliminate the detrimental affects of such a potential change, which will result in enhanced production of hydrocarbons from the well.

[00026] In one aspect, the system **200** using the WPA **260** may be configured to provide a closed-loop system for monitoring the health of the equipment and providing solutions that will tend to enhance, optimize or maximize production from the well as described in more detail below.

[00027] Referring to **FIGs. 2** and **3**, the system **200**, in one aspect, may determine one or more parameters indicative of the health and/or operating environment of the ESP and take actions that may increase the life of the ESP and/or operate it more effectively. Each ESP has operating specification and it is generally recommended that the ESP be operated within its specification limits. The system **200**, in one aspect, may be configured to operate the ESP within an operating envelope **370** or substantially close to the maximum flow curve **350** shown in **FIG. 3**. **FIG. 3** shows a plot **300** of the relationship of the flow rate or throughput (in barrels per day or "BPD") and the head (in foot) corresponding to various frequencies (speeds) of an exemplary ESP installed in a well, such as well **50**. The flow rate is shown along the horizontal axis, while the head is shown along the vertical axis. Each solid curve is a plot of the flow rate versus head corresponding to a particular operating frequency of the ESP. For example, curve **310** corresponds to the frequency of 30Hz, curve **312** corresponds to 60 Hz and curve **314** corresponds to 90 Hz. Dotted line **330** shows the minimum flow rate as a function of frequency and head at which the ESP should be

operated, which may be based on the operating specifications of the ESP or other criterion. Similarly, line **350** corresponds to the maximum desired flow rate from the ESP. Thus, the envelope **370** bounded by the curves **310**, **314**, **330** and **350** defines an operating envelope for the ESP. Curve **380** correspond to the best or optimal operation of the ESP, which may be determined using any desired method or may be set arbitrarily based on the know behavior of the ESPs. In one aspect, the system, as described in more detail later, attempts to operate the ESP in the envelope **370** and may attempt to operate substantially close to line **380**.

[00028] As noted above, various downhole conditions alone or in combination can affect the ESP health and operation. The controller **150** periodically or substantially continuously monitors the downhole sensors to determine various parameters of the ESP, including temperature in or proximate the ESP, absolute pressure at the ESP, differential pressure across the ESP, flow rate through the ESP, power supplied to the ESP and its corresponding frequency. In addition, the controller **150** may utilize any of the above described information, such as information relating to sand production, particle size of solids in the fluid, water cut, presence and extent of chemicals, such as scale, corrosion, paraffin, hydrate and asphaltene to determine their effect on the ESP and may take actions in response to such determination.

[00029] For example, models used by WPA may provide that sand being produced and/or the particle size thereof warrants altering or reducing flow rate from a particular zone, altering power to the ESP, etc. In another aspect, WPA may suggest changing flow rate through ESP when the temperature and/or pressures relating to the ESP does not meet a selected or set criterion, such as the temperature or pressure is too high. In another aspect, WPA may suggest to alter the amount or type chemicals being injected when the system detects that undesired chemicals exceed certain limits or that water cut is above a selected limit so as to prevent or reduce the likelihood of a detrimental affect on the ESP. In another aspect, WPA may predict the impact on the ESP of a single or combination of parameters and suggest corresponding actions. In another aspect, WPA may suggest cleaning the ESP, such as by flushing, in response to the presence of sand, corrosion, scale, hydrate, paraffin or asphaltene or injecting chemicals to the ESP.

[00030] In one aspect, WPA may utilize models, algorithms that use multiple input parameters and provide a set of actions, which actions when executed will provide extended life of the ESP and enhanced production from the well. WPA may use an iterative method, perform a nodal analysis, utilize a neural network or other algorithms to provide the set of actions. The processor may perform similar functions for other fluid lift mechanisms, such as gas lift mechanisms.

[00031] In another aspect, the processor 152 may take one or more actions based on the production of sand. The processor may determine that a particular device, such as a valve or choke has clogged, is clogging at a certain rate or that the sand particle size will damage one or more devices in the well. It may determine the extent to which a particular sand screen has been damaged. The processor using the WPA may suggest to shut in the particular zone, or alter flow from the zone or to flush a choke or valve, etc. The processor also may predict the impact of sand production on one or more devices downhole. Additionally, the processor may utilize the information relating to the ESP described above and suggest a combination of actions, such as altering flow from a choke and that from the ESP in series or substantially simultaneously so as to reduce the sand production, extend the lives of the ESP, choke and/or sand screen, etc.

[00032] The controller also may determine the extent of sand and chemicals passing through the ESP. WPA utilizing one or more of these parameters may estimate or predict a physical condition of the ESP and suggest one or more corrective actions. For example if the temperature of the ESP exceeds a selected value, WPA may suggest that the ESP frequency be increased by a certain amount so as to increase the flow of the fluid through the ESP, which in turn will reduce the temperature to an acceptable level.. Alternatively, or in addition, WPA may suggest reducing the flow rate from a selected zone to reduce the inflow of the sand. WPA may suggest altering the ESP operation based on one or more actual, anticipated or predicted changes in the condition of the well.

[00033] In another aspect, the processor may take one or more actions based on the presence and extent of certain chemicals in the fluid. In one aspect, the processor may suggest altering the chemical injection rate; altering flow rate from a particular zone by changing the position of a choke or valve; moving the position of the choke or valve one or more than one time to remove scale or corrosion from the choke or

valve; increasing production from another zone when changing the choke position is either not feasible or does not produce the desired effect; performing a clean-up, such as flushing, operation, etc.

[00034] In another aspect, the processor may estimate the extent of pipe or casing erosion and provide actions to be taken. The measure of erosion may be an extent of corrosion, scale build-up, location and extent of pits, cracks and gouges, etc. The information about the corrosion, scale, etc. may be provided to or computed by the processor **152**. Well log data, such as obtained from electrical or acoustic logs, may be used to provide quantitative estimates of casing erosion and/or images of the casing. The model, based on one or more of the presence, temperature, extent of the chemical, water production, and other parameters provide the suggested actions. In another aspect, the processor, for example using one or more of the chemical build-up rate, the well log information, water front location and/or other data, may predict or extrapolate the condition of the any device over time, including that of the casing and cement bond; and in response thereto provide suggested actions that will tend to increase the life of the equipment and/or provide enhanced production of hydrocarbons from the well. The actions may be a combination of actions that may include altering a chemical injection rate, performing a clean-up operation, altering a choke or valve position, altering speed of the ESP, altering flow through another artificial lift mechanism, closing in a zone and/or changing production from another zone, etc.

[00035] In another aspect, the processor may determine actions from the condition of the cement bond between the casing and the formation. Cement bond logs (typically acoustic logs) provide logs that can show the location and extent to cracks in the cement bond. The processor using the WPA may extrapolate or predict from the current cement bond log information, the historic information stored in the data base, microseismic measurements, and/or four dimensional seismic the cement bond condition over a time period and its impact on the production of fluids from the well and determine the suggested actions.

[00036] Thus in one aspect, the processor using the WPA utilizes multiple inputs and may use a nodal analysis or neural networks or other algorithms to provide corrective actions that will extend the life of one or more devices in the well and provide

enhanced production of hydrocarbons from the well. WPA, in addition to determining the health of the devices, may estimate the remaining life of the equipment, predict the production rate over time from the well, suggest remedial work, such as flushing, fracturing, workover, etc.

[00037] As described above, the processor sends messages to the operator to take the desired actions, sends such information to the remote controller **185** and displays the desired data for use by the operator. The processor continues to monitor the effects of the actions taken by the operator. Once the operator makes a change, the central controller **150** continues to monitor the various parameters and determines whether the effects of the changes made correspond to the expected results. The controller continues to monitor the health of the various devices, the various parameters and the flow from the various zones. In the case of an ESP, the controller monitors the specific operation point in the envelope **270**, and may continue to cause changes to maintain the ESP operation within the envelope **270** or close to the curve **280**, as the case may be. The controller, however, may determine that in order to achieve enhanced or optimal production, it may be more desirable to operate ESP in a particular sub-region, of the envelope **270**, which may or may not include the maximum flow line **280**, while increasing or decreasing production from one or more zones.

[00038] In another aspect, the controller, using the WPA estimates the expected production rate from the well based on the changes suggested or made and performs a net present value analysis to determine the economic impact of the changes. In one aspect, the controller uses multiple parameters for the model and determines the settings for the various devices that will extend the life of the equipment and/or enhanced production from the well. The inputs may be any combination of parameters, which are selected from the parameters relating to the health of one or more downhole devices, actual operating parameters of the various devices, such as the frequency of ESP, current settings of the chokes, valve, sand production, water cut presence and extent of chemicals, chemical injection rates, downhole temperature and pressure at one or more locations, and other desired parameters. WPA also may use surface measurements or results computed from the surface measurements, downhole measurements or results computed from the downhole measurements, test data,

information from the database and any other information that may be pertinent to a particular well and uses a nodal analysis and/or another forward looking models to obtain the new settings. The nodal analysis may include prediction of the effects of the new settings on the production and iterate this process until a combination of new settings (final plan) is determined that will extend the life of equipment and/or enhance, optimize or maximize the production from the particular well.

[00039] Referring back to **FIG. 2B**, the central controller may be configured to automatically initiate one or more of the recommended actions, for example, by sending command signals to the selected device controllers, such as to ESP controller to adjust the operation of the ESP **242**; control units or actuators (**160, FIG. 1A** and element **240**) that control downhole chokes **244**, downhole valves **246**, surface chokes **249**, chemical injection control unit **250**, other devices **254**, etc. Such actions may be taken in real time or near real time. The central controller **150** continues to monitor the effects of the actions taken **264**. In another aspect, the central controller **150** or the remote controller **185** may be configured to update one or more models/algorithms/programs **234** for further use in the monitoring of the well. Thus, the system **200** may operate in a closed-loop form to monitor the performance of the well, take or cause to take desired actions, and continue to monitor the effects of such actions.

[00040] While the foregoing disclosure is directed to the certain exemplary embodiments and methods, various modifications will be apparent to those skilled in the art. It is intended that all such modifications within the scope of the appended claims be embraced by the foregoing disclosure. Also, the abstract is provided to meet certain statutory requirements and is not be used to limit the scope of the claims.

What is claimed is:

1. A method of producing fluid from a well, comprising:
 - determining a first setting of at least one first downhole device that is under use for producing the fluid from the well;
 - selecting a set of parameters that includes at least one parameter relating to health of at least one second downhole device and a plurality of parameters selected from a group comprising flow rate, pressure, temperature, presence of a selected chemical, water content, sand content, and chemical injection rate; and
 - using the selected set of parameters as an input to a computer model to determine a second setting for the at least one first downhole device that will provide an increased life of the at least one second downhole device and enhanced flow rate for the fluid from the completed well; and
 - setting the at least one first downhole device to the second setting.
2. The method of claim 1, further comprising operating the well corresponding to the second setting of the at least one first downhole device and determining a performance of the well based on the second setting.
3. The method of claim 1, wherein the at least one parameter relating to the health of the at least one second downhole device relates to at least one of: an electrical submersible pump; a valve; a choke; a casing lining the well; a pipe carrying the fluid from the well toward the surface; and a sand screen.
4. The method of claim 1 or 2, further comprising:
 - estimating a flow rate from the well over an extended time period based on the second setting; and
 - estimating a net present value for the well corresponding to the estimated flow rate for the extended time period.

5. The method of claim 1, wherein the group further consists of information relating to: resistivity, density of the fluid, fluid composition, a capacitance measurement relating to the fluid, vibration, acoustic measurements in the well, differential pressure across a device in the well, oil-water ratio, and gas-oil ratio.
6. The method of claim 1, wherein the group further consists of: microseismic measurements, pressure transient test measurements, well log measurements, and a measurement relating to presence of: one of scale, hydrate, corrosion, paraffin, and asphaltene.
7. The method of claim 1 or 2, further comprising:
predicting an occurrence of one of: water breakthrough, cross-flow condition, and breakdown of a device installed in the well; and
determining the second setting based on such prediction.
8. The method of claim 1 or 2, wherein the second setting constitutes at least one of: altering the chemical injection rate, altering an operation of an electrical submersible pump, shutting in a selected production zone, altering position of a choke, altering position of a valve, and altering flow through an artificial lift mechanism.
9. The method of claim 1 to 2, further comprising sending a message relating to the second setting to at least one of: an operator, and a remote location from the well.
10. The method of claim 1 or 2, further comprising using a processor that automatically sets the at least one first downhole device to the second setting.

11. A computer system for controlling an operation of an electrical submersible pump placed in a well for producing a fluid from the well, comprising:

a database that stores information corresponding to one of:

an operating envelope for the electrical submersible pump that is based on a relationship among fluid flow rate, frequency and head over the electrical submersible pump; and

a maximum flow rate for the electrical submersible pump corresponding to the frequency and head; and

a processor that utilizes at least one measured operating parameter of the electrical submersible pump and the information stored in the database and determines a setting for at least the electrical submersible pump and another downhole device that will cause the electrical submersible pump to operate according to one of: within the envelope, and proximate the maximum flow rate.

12. The computer system of claim 11, wherein the measured operating parameter of the electrical submersible pump is one of a: flow rate, frequency, temperature, pressure proximate the electrical submersible pump, and differential pressure across a wellbore segment proximate the electrical submersible pump.

13. The system of claim 11, wherein the processor determines the setting such that the determined setting maintains one of temperature, pressure and differential pressure associated with the electrical submersible pump within a selected limit.

14. The system of claim 11 or 13, wherein the setting is one of altering: frequency of the electrical submersible pump, power to the electrical submersible pump, position of a choke, position of a valve, and flow from a selected zone.

15. The system of claim 11, wherein the processor further determines a chemical injection rate that will inhibit formation of one of: scale, corrosion, paraffin, hydrate and asphaltene in the fluid in the well.
16. The system of claim 11 or 12, further comprising a display and wherein the processor displays messages relating to operation of the well and the electrical submersible pump.
17. The system of claim 11 or 13, wherein the processor sends command signals to cause the electrical submersible pump and the other downhole device to operate according to the determined setting.
18. The system of claim 11, wherein the processor estimates the expected life of the electrical submersible pump based on its current operation parameters and a plurality of parameters relating to the well.
19. A method of controlling operation of an electrical submersible pump in a well that is producing fluids, comprising:
- determining an operating envelope for the electrical submersible pump that is based on a relationship among fluid flow rate, frequency and head over the electrical submersible pump and includes a maximum flow rate for the electrical submersible pump corresponding to the frequency and head;
 - measuring an operating parameter of the electrical submersible pump using a sensor in the well; and
 - altering an operation of one of the electrical submersible pump and a downhole device to operate the electrical submersible pump according to one of: within the operating envelope; and proximate the maximum flow rate.

20 The method of claim 19 further comprising operating the electrical submersible pump within the operating envelope and below one of a selected: temperature, pressure, and differential pressure.

21. The method of claim 20 further comprising altering injection of a chemical from a surface location that inhibits formation of one of corrosion, scale, hydrate, paraffin and asphaltene proximate the electrical submersible pump.

22. A computer-readable medium that has embedded therein a computer program that is accessible to a processor for executing instructions contained in the computer program, the computer program comprising:

instructions to determine a first setting of at least one first downhole device while in use for producing the fluid from the well;

instructions to select a first set of input parameters that includes at least one parameter relating to health of at least one second downhole device and a plurality of parameters selected from a group consisting of: information relating to flow rate, pressure, temperature, presence of a selected chemical, water content, sand content, and chemical injection rate;

instructions to use the selected first set of parameters as an input to determine a second setting for at least one first downhole device that will provide at least one of an increased life of the at least one second downhole device and enhanced flow rate for the fluid from the completed well; and

instructions to send signals to operate the well corresponding to the second setting of the at least one first downhole device.

23. The computer-readable medium of claim 22 wherein the computer program further comprises:

instructions to estimate performance of the well based on the second setting.

24. The computer-readable medium of claim 22, wherein the at least one parameter relating to the health of the at least one second downhole device relates to at least one of: an electrical submersible pump, a valve, a choke, a casing lining the well, a pipe carrying the fluid from the well toward the surface, and a sand screen.

25. The computer-readable medium of claim 22 or 23, wherein the computer program further comprises:

instructions to estimate a flow rate from the well over an extended time period based on the second setting; and

instructions to estimate a net present value for the well corresponding to the estimated flow rate for the extended time period.

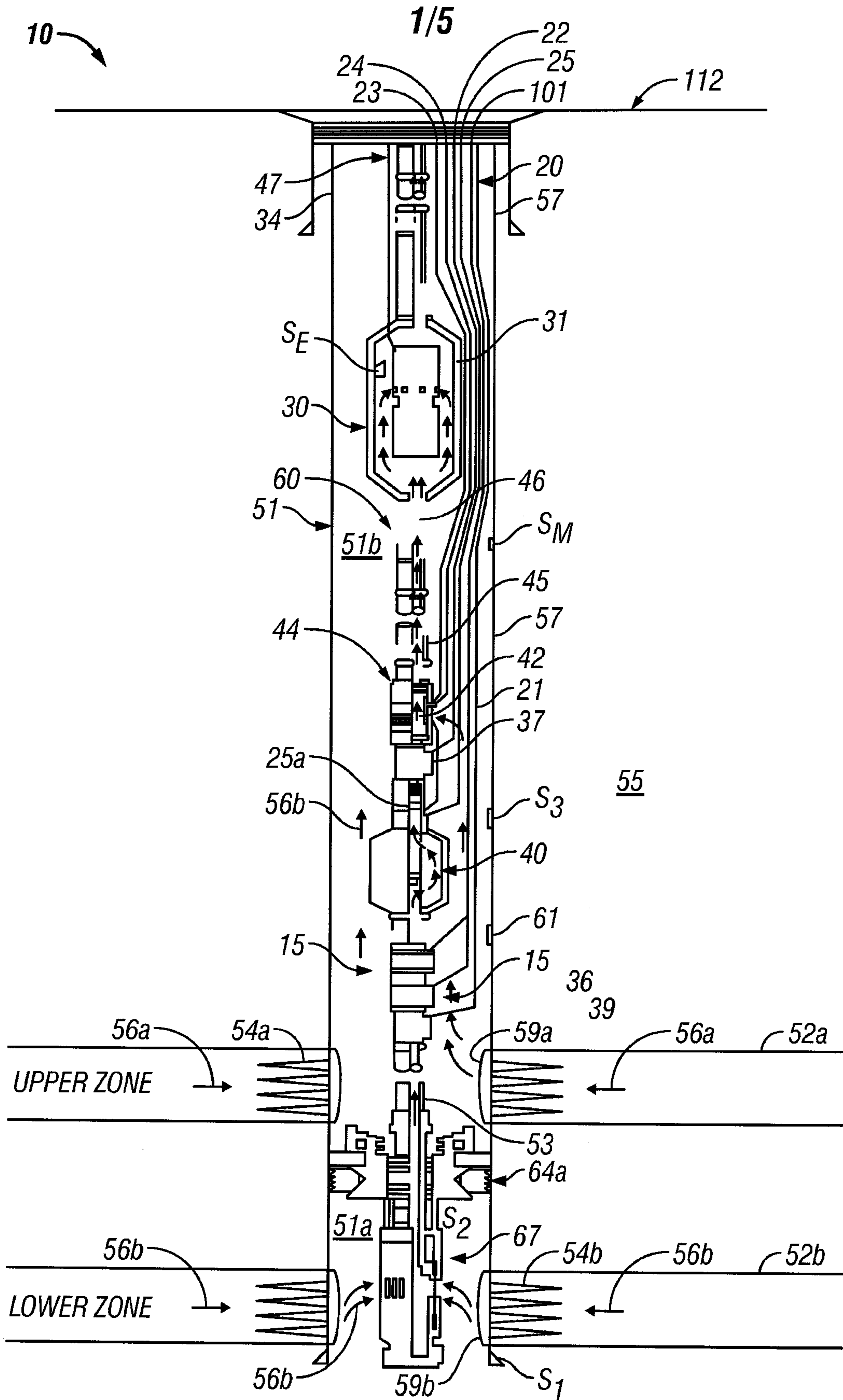

FIG. 1A

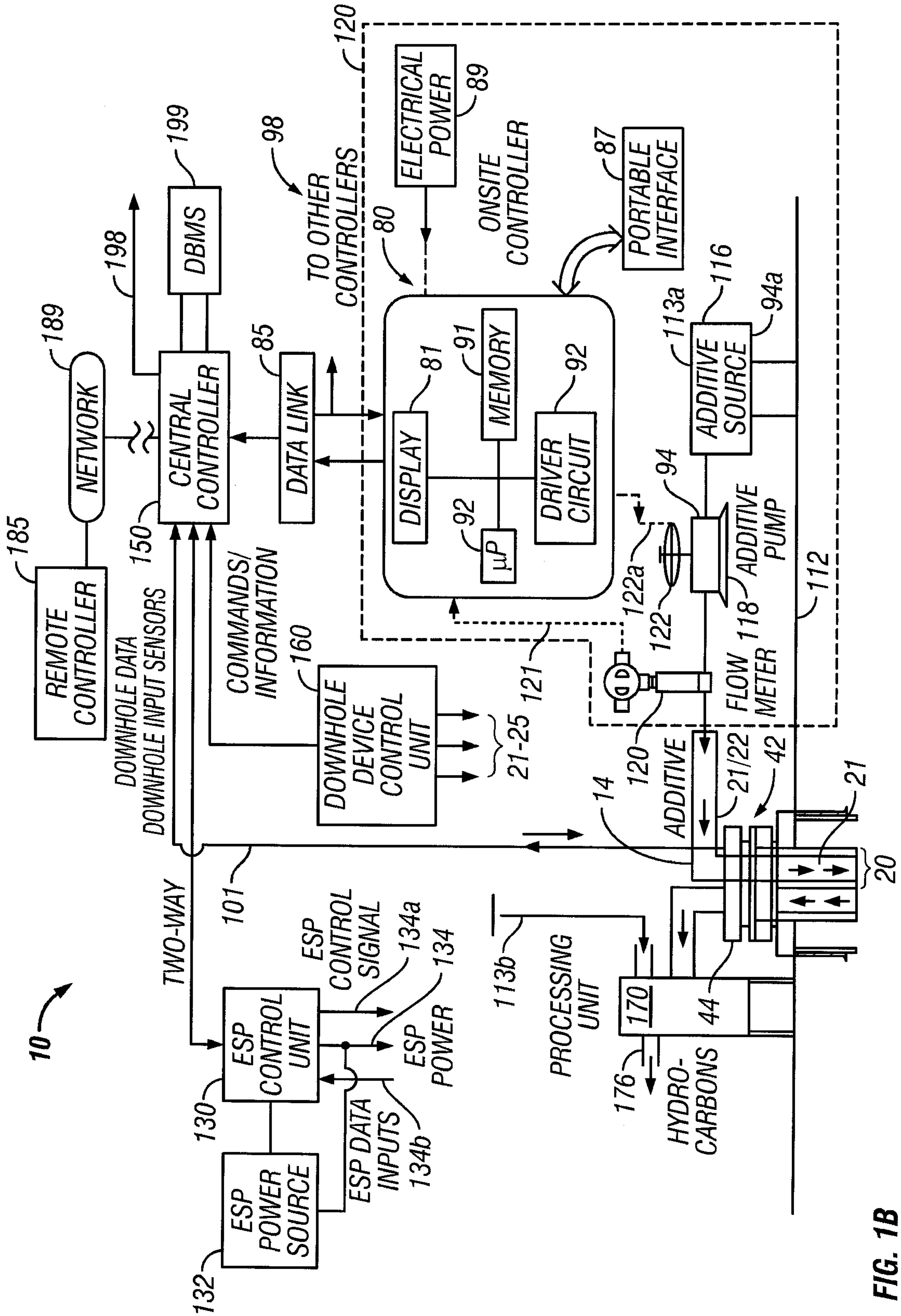

FIG. 1B

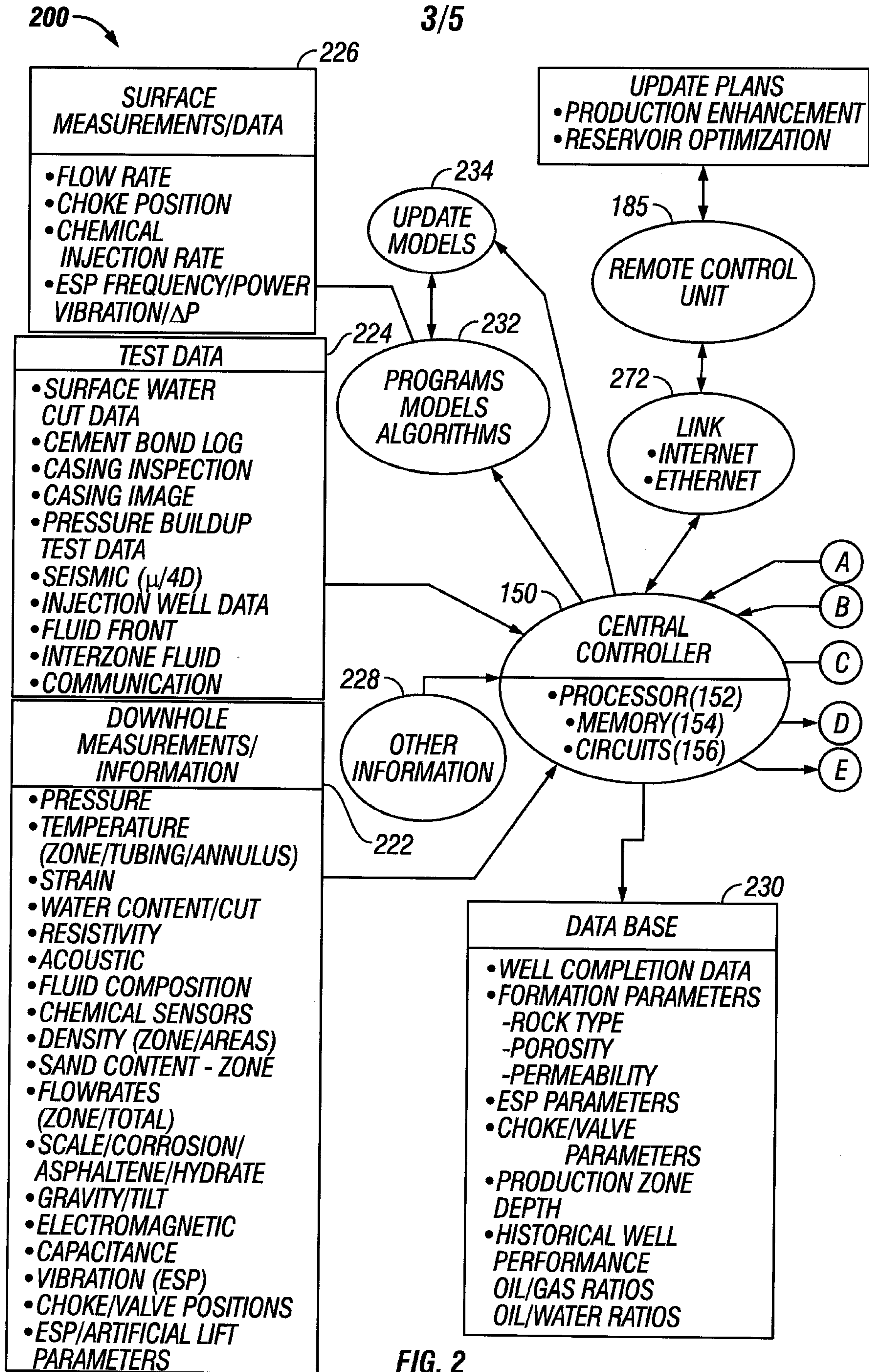

FIG. 2

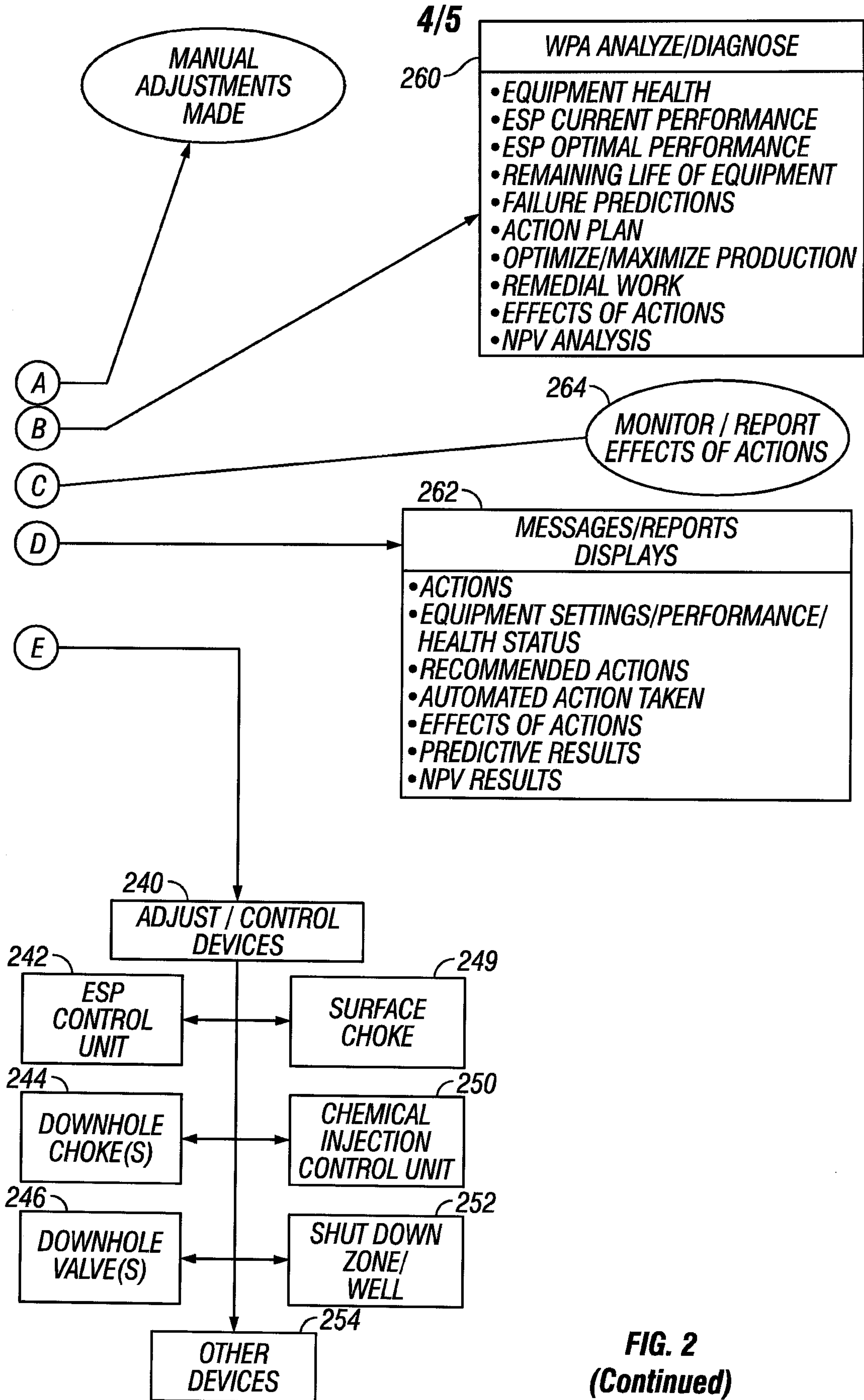

FIG. 2
(Continued)

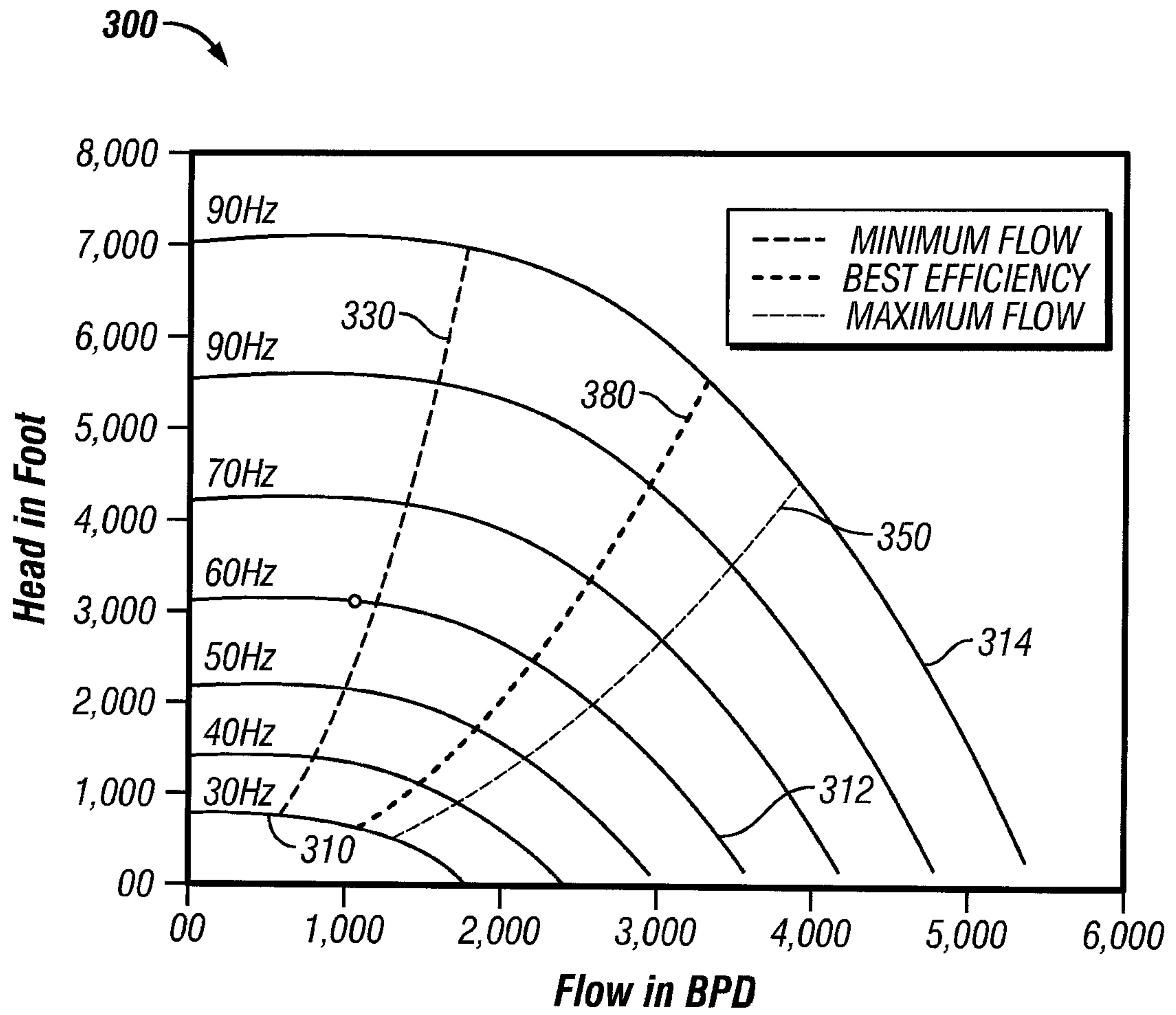

FIG. 3

