

No. 688,465.

Patented Dec. 10, 1901.

E. F. GÖRANSSON.  
MOVEMENT CURE APPARATUS.

(Application filed Jan. 8, 1900.)

(No Model.)

2 Sheets—Sheet 1.

FIG. 3-

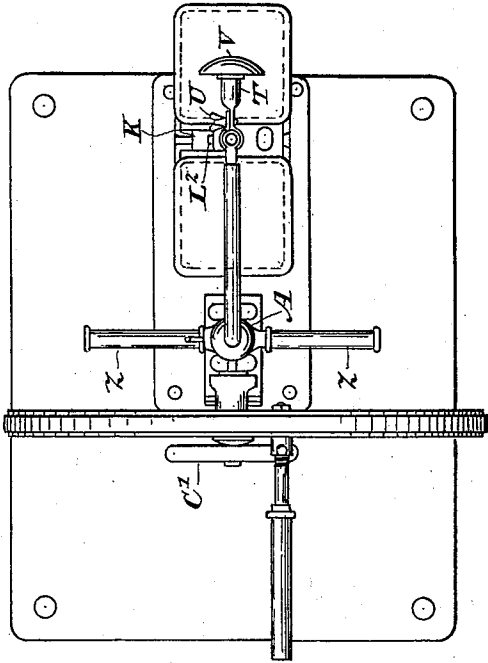
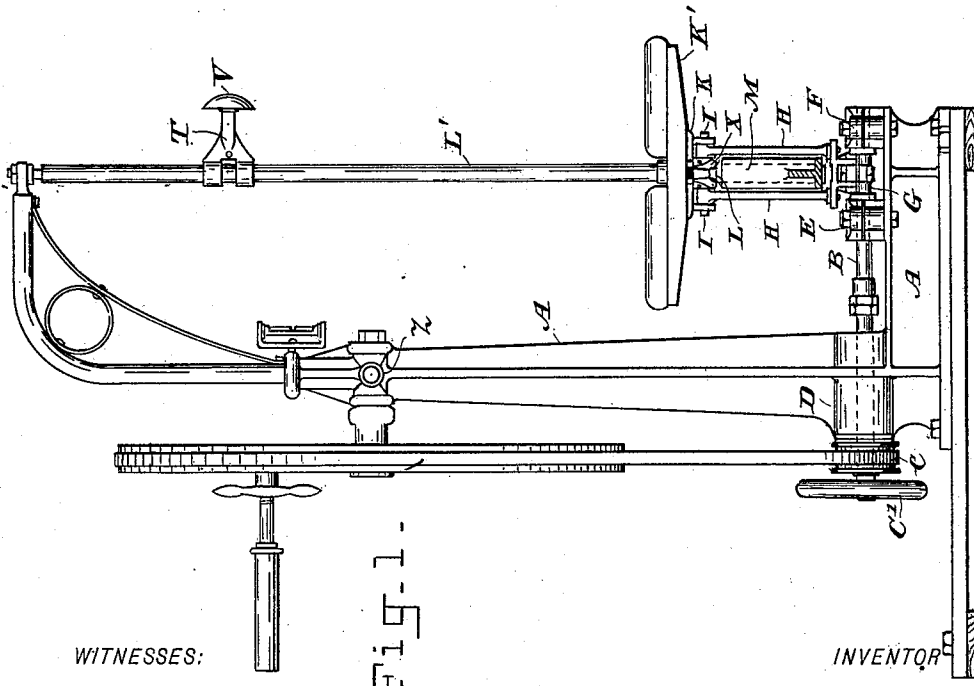
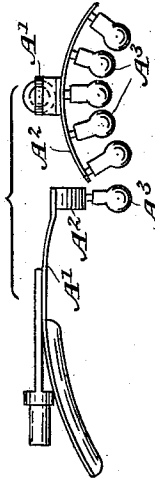

FIG. 5-



WITNESSES:

*E. B. Bolton*  
*O. W. Mumford*

FIG. 1-

INVENTOR

*E. F. Göransson*  
BY  
*Richardson*  
ATTORNEYS

No. 688,465.

Patented Dec. 10, 1901.

E. F. GÖRANSSON.  
MOVEMENT CURE APPARATUS.

(Application filed Jan. 8, 1900.)

(No Model.)

2 Sheets—Sheet 2.

Fig. 4-

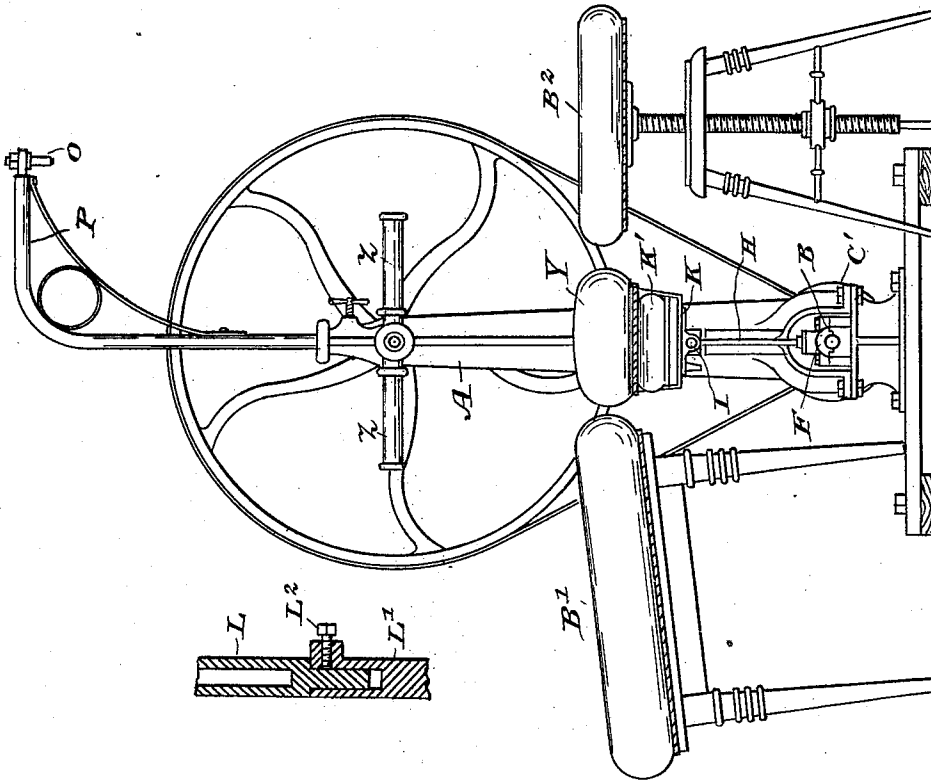
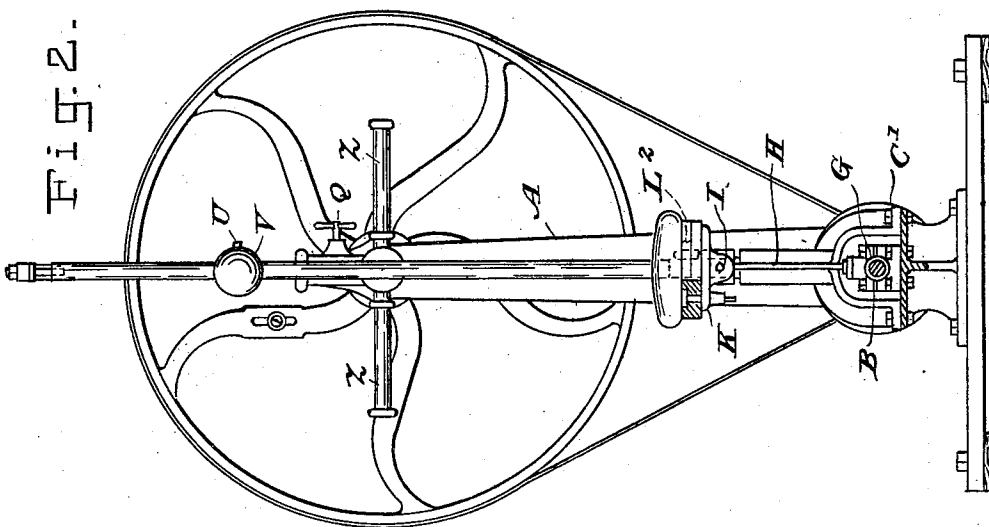

Fig. 2-



WITNESSES:

*E. B. Bolton*  
*Albert*

INVENTOR

*Ernst Fredrik Goransson*  
BY  
*Richardson*  
ATTORNEYS

# UNITED STATES PATENT OFFICE.

ERNST FREDRIK GÖRANSSON, OF STOCKHOLM, SWEDEN.

## MOVEMENT-CURE APPARATUS.

SPECIFICATION forming part of Letters Patent No. 688,465, dated December 10, 1901.

Application filed January 8, 1900. Serial No. 735. (No model.)

To all whom it may concern:

Be it known that I, ERNST FREDRIK GÖRANSSON, mechanical engineer, a subject of the King of Sweden and Norway, and a resident of Grefmagnigatan 13, Stockholm, in the Kingdom of Sweden, have invented certain new and useful Improvements in Movement-Cure Apparatus, (for which I have filed applications for patent in Sweden the 25th day of November, 1899, under No. 1,988/99; in Germany the 8th day of December, 1899; in Austria the 9th day of December, 1899; in Great Britain the 12th day of December, 1899, under No. 24,711/99; in France the 12th day of December, 1899, under No. 283,355, and in Italy the 14th day of December, 1899,) of which the following is a specification, reference being had therein to the accompanying drawings.

This invention relates to a gymnastic, massage, or like apparatus which, unlike the apparatus already known, is not operated by the hand, but is provided with a rigid support fixed or standing on the floor. It is characterized partly by a vertical rod, which is given a rapid reciprocating motion up and down and on which are mounted the various rubbers or parts for administering the various motions to a person sitting, lying, or standing near it and partly by the construction of the rod itself, which is composed lengthwise of the two parts, the upper one of which can be removed and a cushion applied instead on the lower part, so that it is possible with the same apparatus to obtain also so-called "saddle-sitting" vibrations, treatment of the back and body of the patient or user in a lying-down position, &c. The apparatus is so constructed that with slight alterations it can be driven either by hand or by belt from a line-shaft or by a motor.

Figure 1 shows the apparatus viewed from one side; Fig. 2, in front view, partly in section; Fig. 3, in a plan view. Fig. 4 shows the apparatus as arranged for back or body treatment, and Fig. 5 shows an attachment for head massage or treatment.

A is the frame proper, in which the crank or eccentric shaft B, with belt-pulley C and fly-wheel C', is journaled in boxes D, E, and F. The connecting-rod consists of two rods H, secured to the head G and jointed by means of pins I to a plate K, secured to the lower

part L of the above-mentioned vertical rod, the upper part L' of which is composed of a tube inserted in the lower part and secured by a set-screw L<sup>2</sup> or the like, so as to be readily released. The rod is guided in a socket M, secured to or forming part of the frame A and surrounding the lower end of the rod, and by a pin O entering its upper end and attached to an arm P, which is rotatably mounted on or in the frame A and is secured in position by a set-screw Q. When the latter is slackened, the arm P can be elevated and turned to one side if the tube L' is not required for use. The rod L L' is given a reciprocating motion up and down when the shaft B is rotated.

On the tube L' is a holder T, which by loosening its thumb-nut U can be pushed up and down on the tube and secured in different positions. In this holder various rubbers or appliances may be secured, one of which is shown in the drawings—viz., a small cushion V, which in the rapid up-and-down motion of the rod communicates a vibrating or rubbing motion to different parts of the body as they are pressed against it. Another appliance (shown in Fig. 5) consists of a segment-plate A<sup>2</sup>, provided with a bar A' and fitted with rubber balls A<sup>3</sup>. When this appliance is mounted on the holder T, an up-and-down movement is communicated to the balls, so that a person placing, for instance, his head under it receives so-called "head massage" or treatment. The shoulders and neck may be treated with the same appliance. The feet and legs may be operated upon if the patient places himself on a chair and the calves of his legs on a padded wooden plate K', which being secured to the plate K by a thumb-nut X forms a cross-piece with the rod L L'. Fig. 4 shows the apparatus when the arm P, with its pin O, is turned to one side, the tube L' being removed and a cushion Y placed over the padded plate K'. A person may place himself astride or transversely on said cushion while holding onto the handle Z, and when the cushion is reciprocated rapidly up and down he is treated to a so-called "saddle-sitting" vibration. For treating the back or body the patient or user places the padded bench B' on one side of the apparatus and the padded stool B<sup>2</sup> on the

other and lies upon them in the desired position.

The advantage of constructing the apparatus in this manner lies in the fact that it need be provided with but one crank for administering all the usual motions, and consequently the apparatus, which is well adapted for home use, is simple in construction, takes up a comparatively small space, and can with great facility be driven by hand-power.

When the apparatus is to be driven by belt, a fast and a loose pulley are mounted on the shaft.

Having now described my invention, what I claim as new, and desire to secure by Letters Patent, is—

1. In combination, the vertical rod L L', its cross-piece K, the link-rods H H connect-

ing the latter with the crank of a shaft B, a sleeve M on the frame, in which the rod is guided, and a laterally-adjustable support P for steadying the rod at the top, substantially as shown and described.

2. In combination, the vertical rod L L', its holder T, and mounted on the latter an application-piece consisting of a segment A<sup>2</sup> provided with a shank A' and lined with elastic balls A<sup>3</sup> for administering head-shaking, for instance, substantially as shown and described.

In witness whereof I have hereunto signed my name in the presence of two subscribing witnesses.

ERNST FREDRIK GÖRANSSON.

Witnesses:

ERNST SVANGVIST,

A. F. LUNDBORG.