



US00RE40460E

(19) **United States**  
(12) **Reissued Patent**  
**Savoie**

(10) **Patent Number:** **US RE40,460 E**  
(45) **Date of Reissued Patent:** **Aug. 19, 2008**

(54) <b>METHOD OF USING REMOVABLE CLEAT SYSTEM</b>	2,026,280 A	12/1935	Kerin .....	36/59 R
	2,607,134 A	8/1952	Langer .....	36/67 A
	3,133,363 A	5/1964	Phillips .....	36/67 D
(75) Inventor: <b>Armand J. Savoie</b> , Gardner, MA (US)	3,267,593 A	8/1966	Turner .....	36/59 R
	3,731,406 A	5/1973	Young .....	36/67 D
(73) Assignee: <b>Cleats LLC</b> , Marlborough, MA (US)	4,035,934 A	7/1977	Hrivnak .....	36/67 D
	4,414,763 A	11/1983	Bente .....	36/134
(21) Appl. No.: <b>10/847,811</b>	4,445,288 A	5/1984	Fror .....	36/134
	4,492,047 A	1/1985	Arff .....	36/134
(22) Filed: <b>May 18, 2004</b>	4,633,600 A	1/1987	Dassler et al. ....	36/134

**Related U.S. Patent Documents**

Reissue of:

- (64) Patent No.: **6,463,681**
- Issued: **Oct. 15, 2002**
- Appl. No.: **09/715,495**
- Filed: **Nov. 17, 2000**

U.S. Applications:

- (63) Continuation of application No. 09/641,117, filed on Aug. 17, 2000, now abandoned, which is a division of application No. 09/208,180, filed on Dec. 9, 1998, now Pat. No. 6,108,944, which is a continuation-in-part of application No. 09/062,037, filed on Apr. 17, 1998, now Pat. No. 6,151,805, which is a continuation-in-part of application No. 08/774,585, filed on Dec. 23, 1996, now Pat. No. 5,768,809.
- (60) Provisional application No. 60/010,099, filed on Jan. 17, 1996.

- (51) **Int. Cl.**  
*A43B 5/00* (2006.01)  
*A43B 23/28* (2006.01)  
*A43C 15/00* (2006.01)

- (52) **U.S. Cl.** ..... 36/134; 36/67 A; 36/67 D; 36/61; 36/127; 24/590
- (58) **Field of Classification Search** ..... 403/348, 403/350, 361, 352, 345, 363; 36/134, 116, 36/114, 67 R, 67 D, 62, 66, 59 R, 126, 127, 36/139, 131; 24/590, 591; 215/332; 220/293, 220/297, 298, 300, 301, 302  
See application file for complete search history.

- (56) **References Cited**  
U.S. PATENT DOCUMENTS

1,758,408 A 5/1930 Pierce et al. .... 366/67 D

(Continued)

**FOREIGN PATENT DOCUMENTS**

DE	31 34 817	3/1983	
DE	3134817	* 3/1983	36/134
DE	32 42 606	8/1983	
DE	3242606	* 8/1983	36/127
DE	34 23 363	1/1986	
DE	3423363	* 1/1986	36/127
EP	0 090 884	10/1982	
EP	0090884	* 10/1982	36/127
EP	223700	5/1987	
EP	0 360 202	3/1990	
EP	0360202	* 3/1990	36/134
GB	320029	* 10/1929	

*Primary Examiner*—Anthony Stashick  
(74) *Attorney, Agent, or Firm*—Bromberg & Sunstein LLP

(57) **ABSTRACT**

A removable cleat for a shoe is described. The cleat includes a ground-engaging structure for engaging the ground. An attachment structure is for removably attaching the cleat to the footwear. The attachment structure has a vertical axis, a base to which the top of the ground-engaging member is attached, and multiple extensions projecting radially outward from the base. The extensions are adapted for insertion into a cleat receptacle in the shoe to engage a receptacle attachment structure within the receptacle, so that when the cleat is attached to the receptacle, each cleat extension will be securely engaged above a receptacle restraining ledge.

**37 Claims, 17 Drawing Sheets**

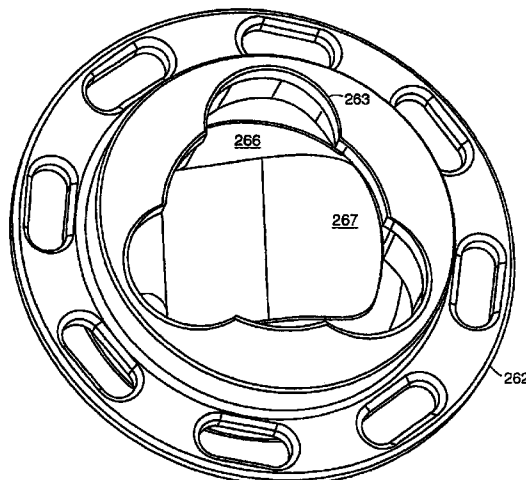

# US RE40,460 E

Page 2

---

## U.S. PATENT DOCUMENTS

4,651,448 A	3/1987	Chen .....	36/134	5,386,651 A	2/1995	Okamoto .....	36/134
4,667,422 A	5/1987	Yamaguchi .....	36/67 A	5,454,587 A *	10/1995	Halford et al. ....	403/348
4,698,923 A	10/1987	Arff .....	36/128	5,475,937 A	12/1995	Korsen .....	36/134
4,723,366 A	2/1988	Hagger .....	36/134	5,628,129 A	5/1997	Kilgore et al. ....	36/134
4,762,437 A	8/1988	Mitomi .....	403/348	5,768,809 A	6/1998	Savoie .....	36/134
5,036,606 A	8/1991	Erich et al. ....	36/134	6,108,944 A	8/2000	Savoie .....	36/134
5,094,148 A *	3/1992	Haber et al. ....	403/348	6,151,805 A	11/2000	Savoie	
5,321,901 A	6/1994	Kelly .....	36/134	6,332,281 B1	12/2001	Savoie	
				6,463,681 B1	10/2002	Savoie	

\* cited by examiner

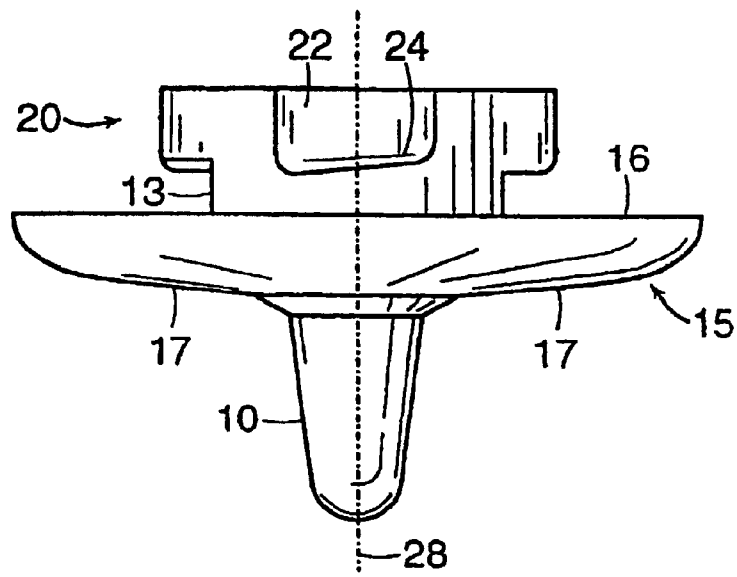

FIG. 1

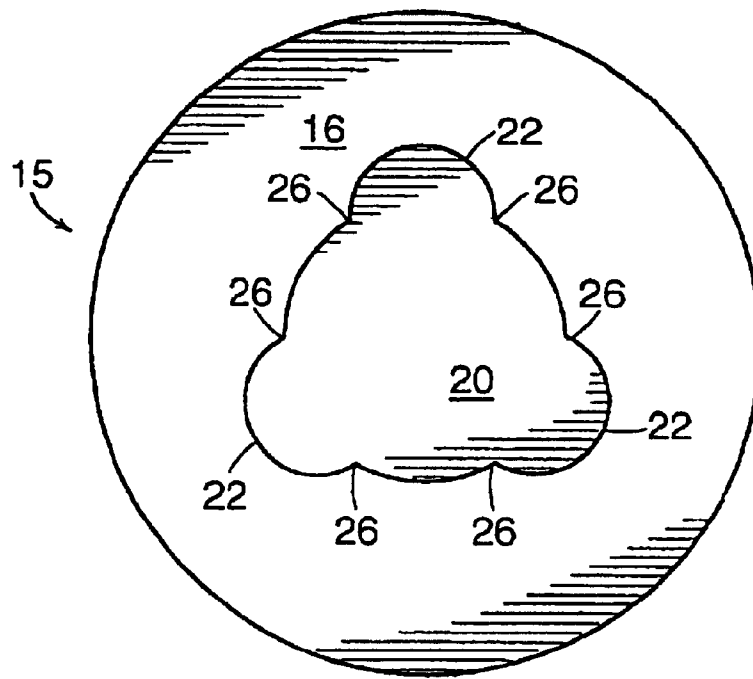

FIG. 2

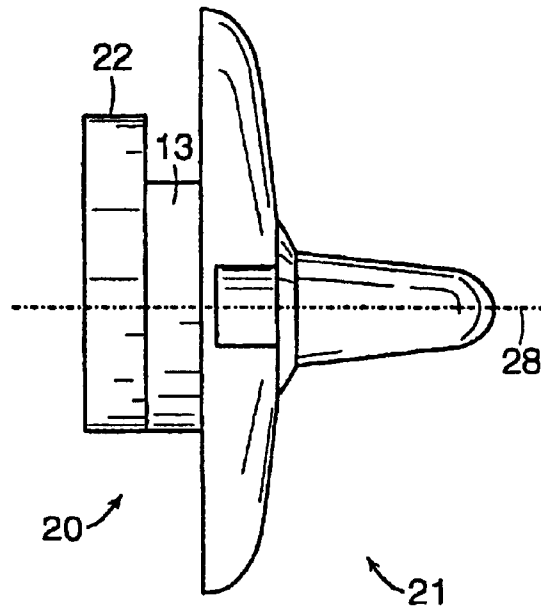

FIG. 3

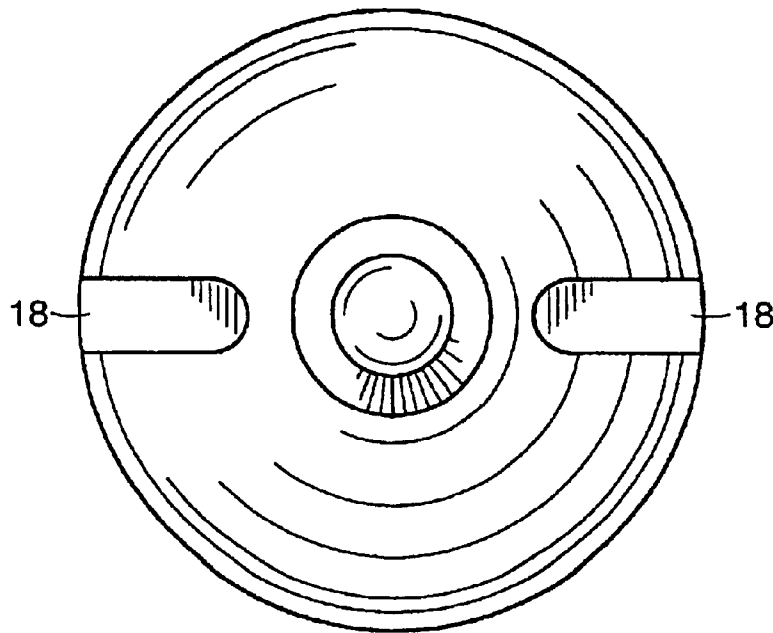

FIG. 4

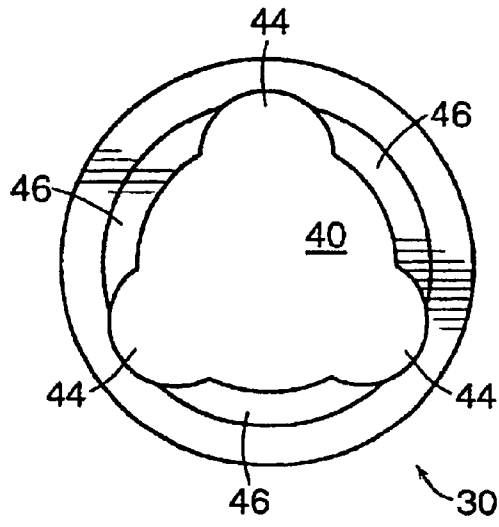

FIG. 5

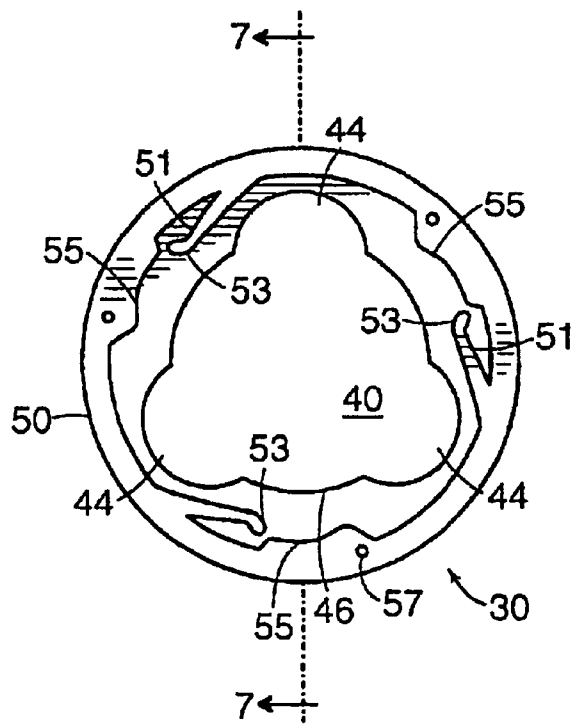

FIG. 6

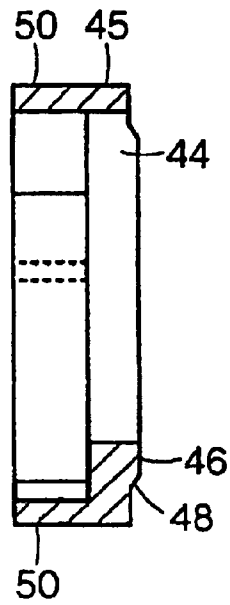

FIG. 7

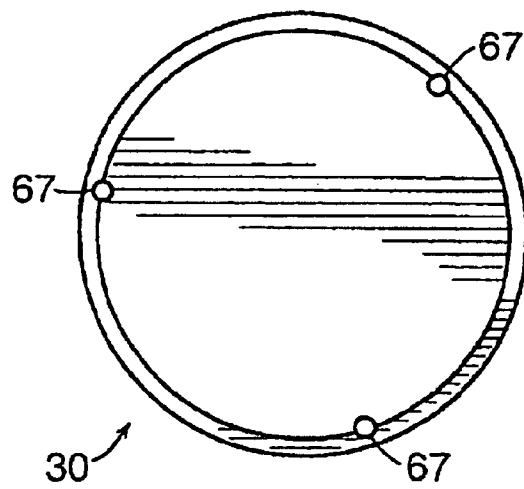

FIG. 8

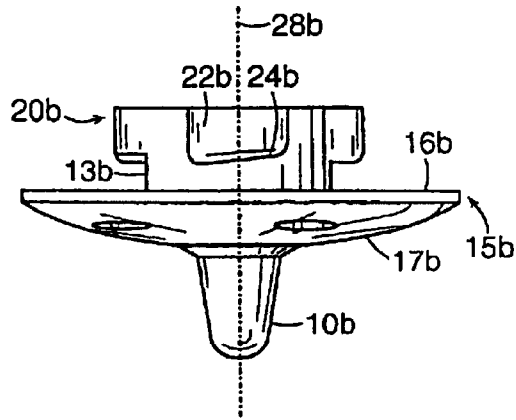

FIG. 9A

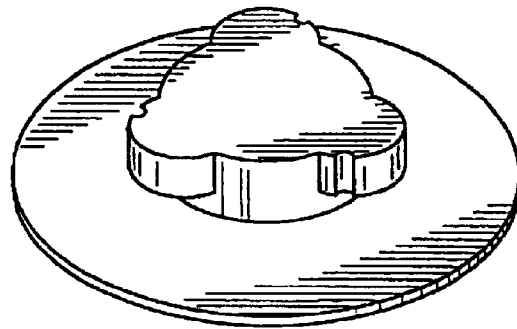

FIG. 9B

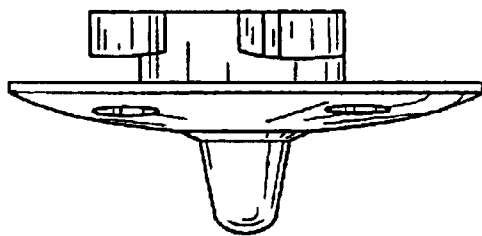

FIG. 9C

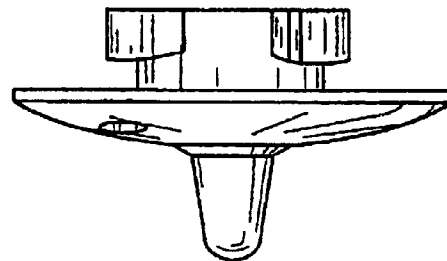

FIG. 9D

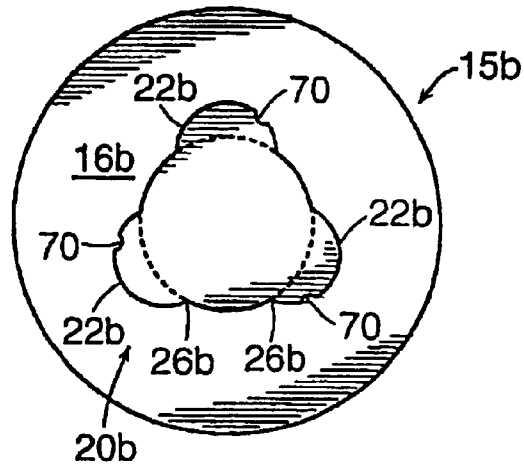

FIG. 10

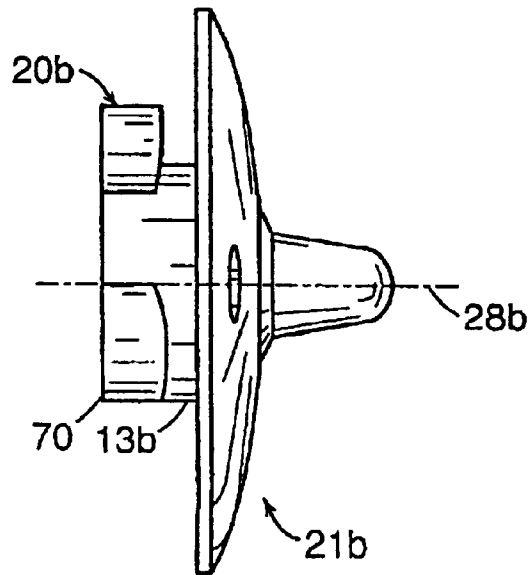

FIG. 11



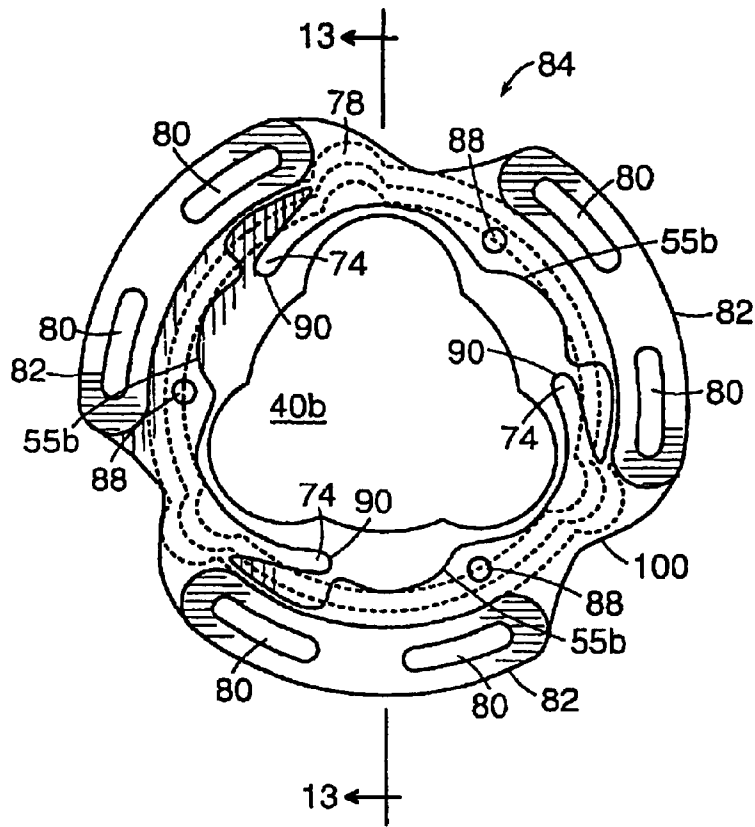

FIG. 12A

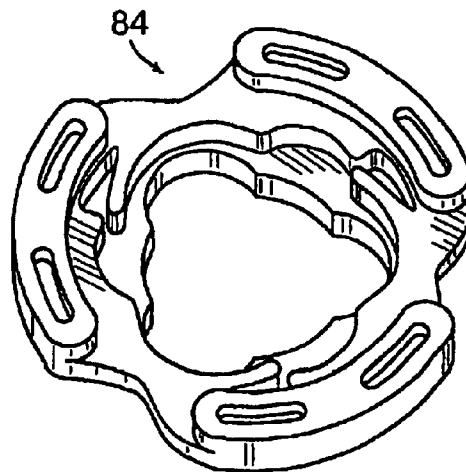

FIG. 12B

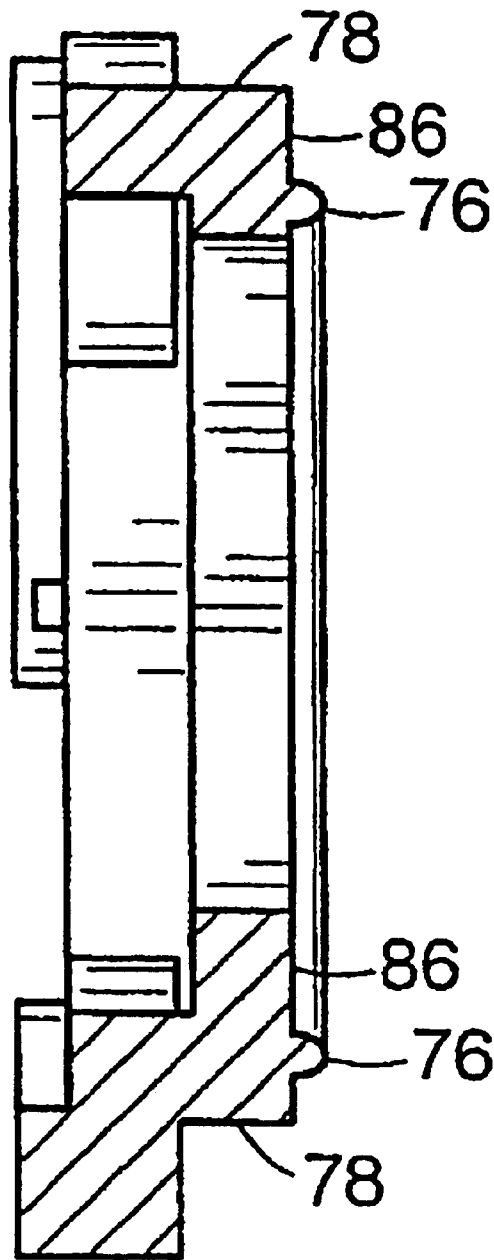

FIG. 13

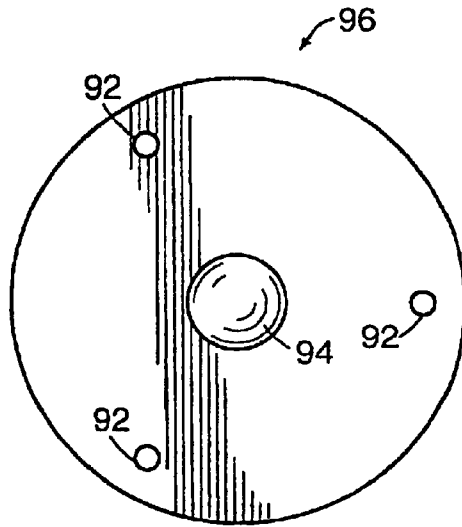

FIG. 14

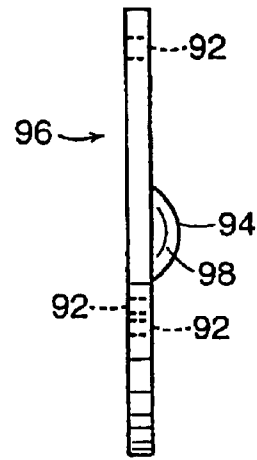

FIG. 15

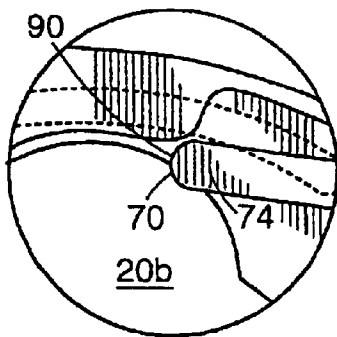

FIG. 16

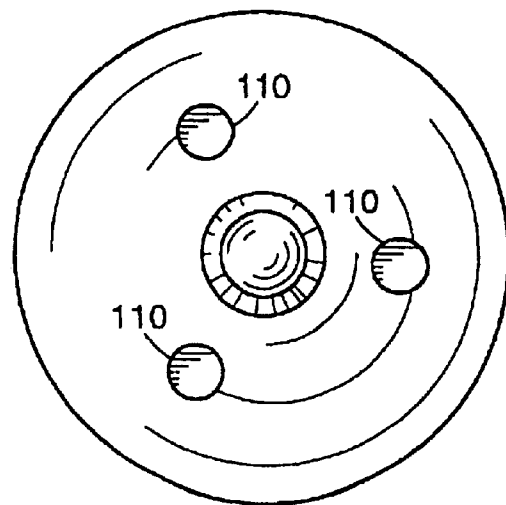

FIG. 17

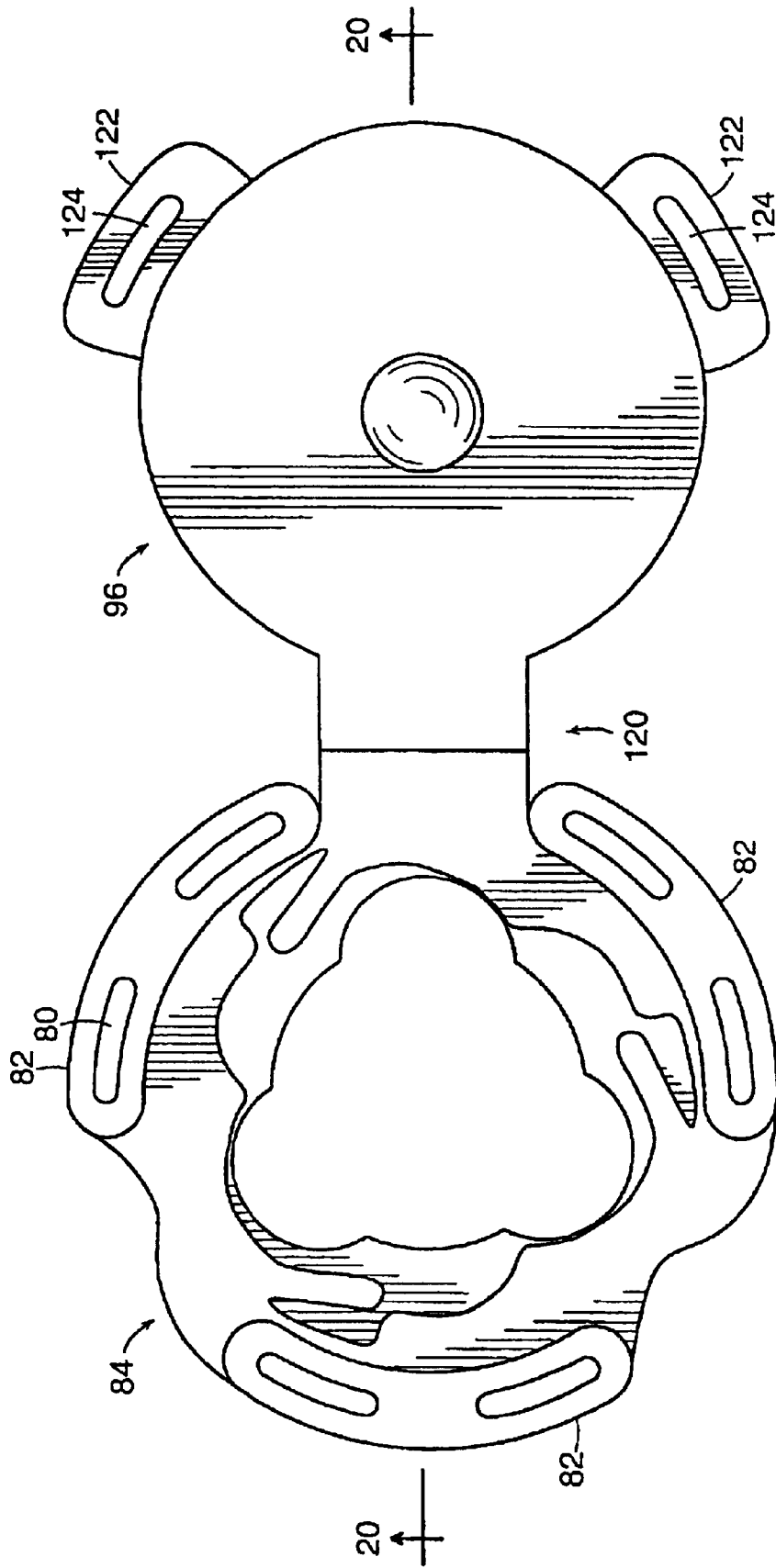

FIG. 18

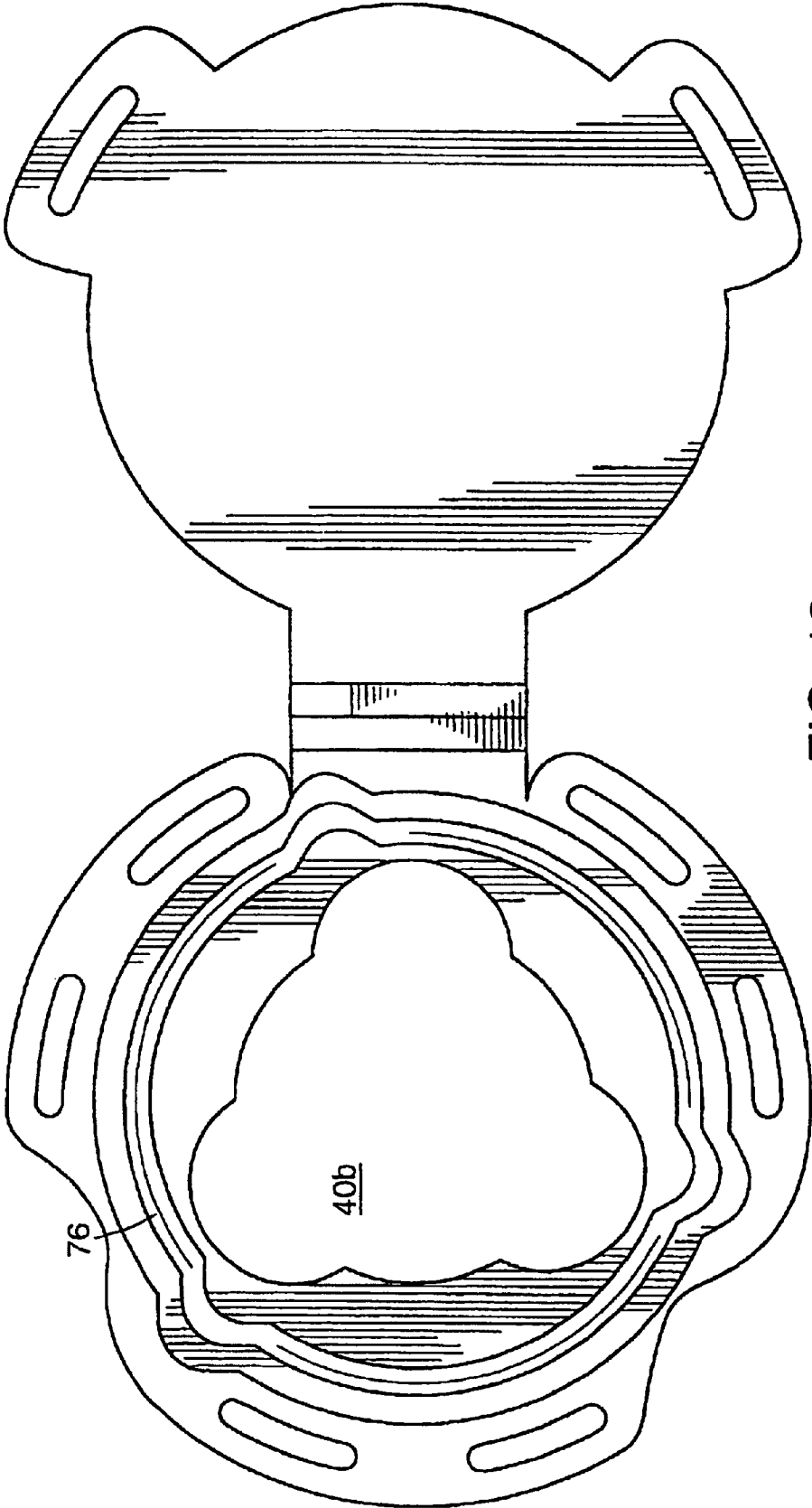

FIG. 19

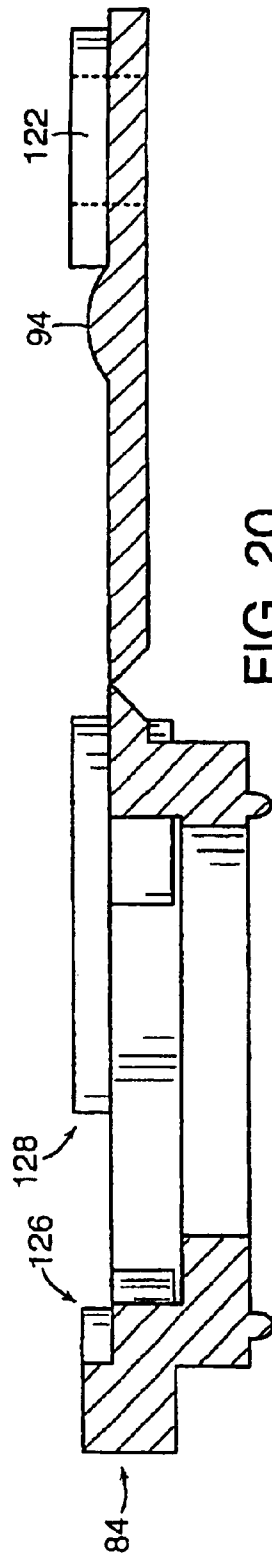

FIG. 20

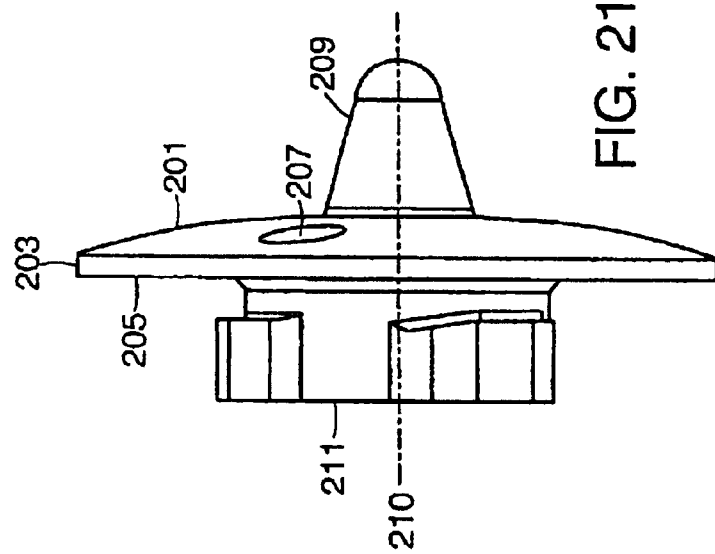

FIG. 21

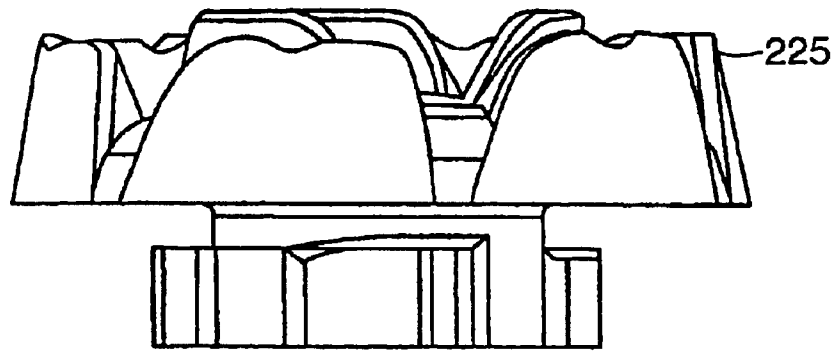

FIG. 22

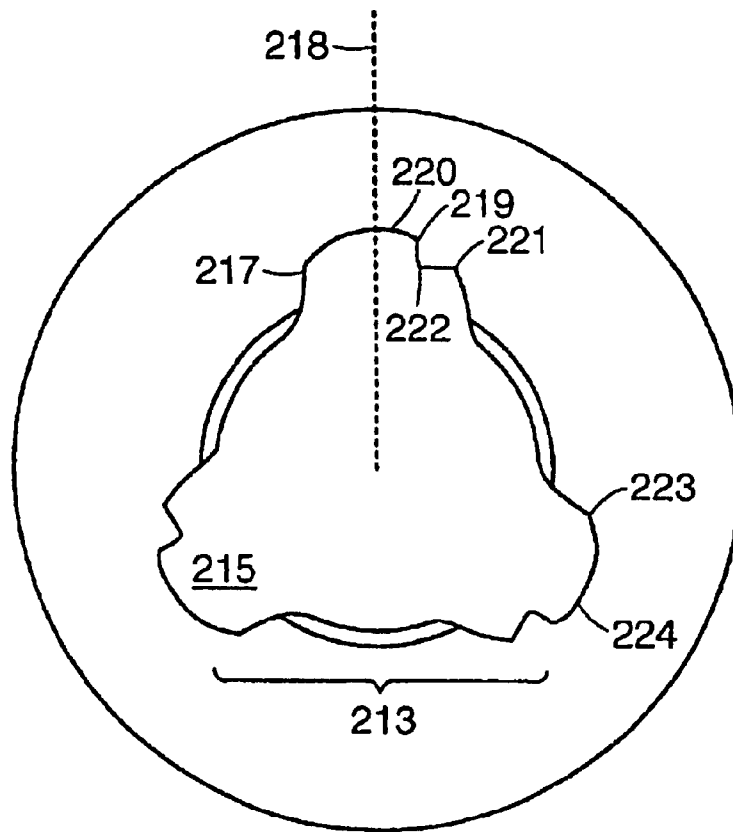

FIG. 23

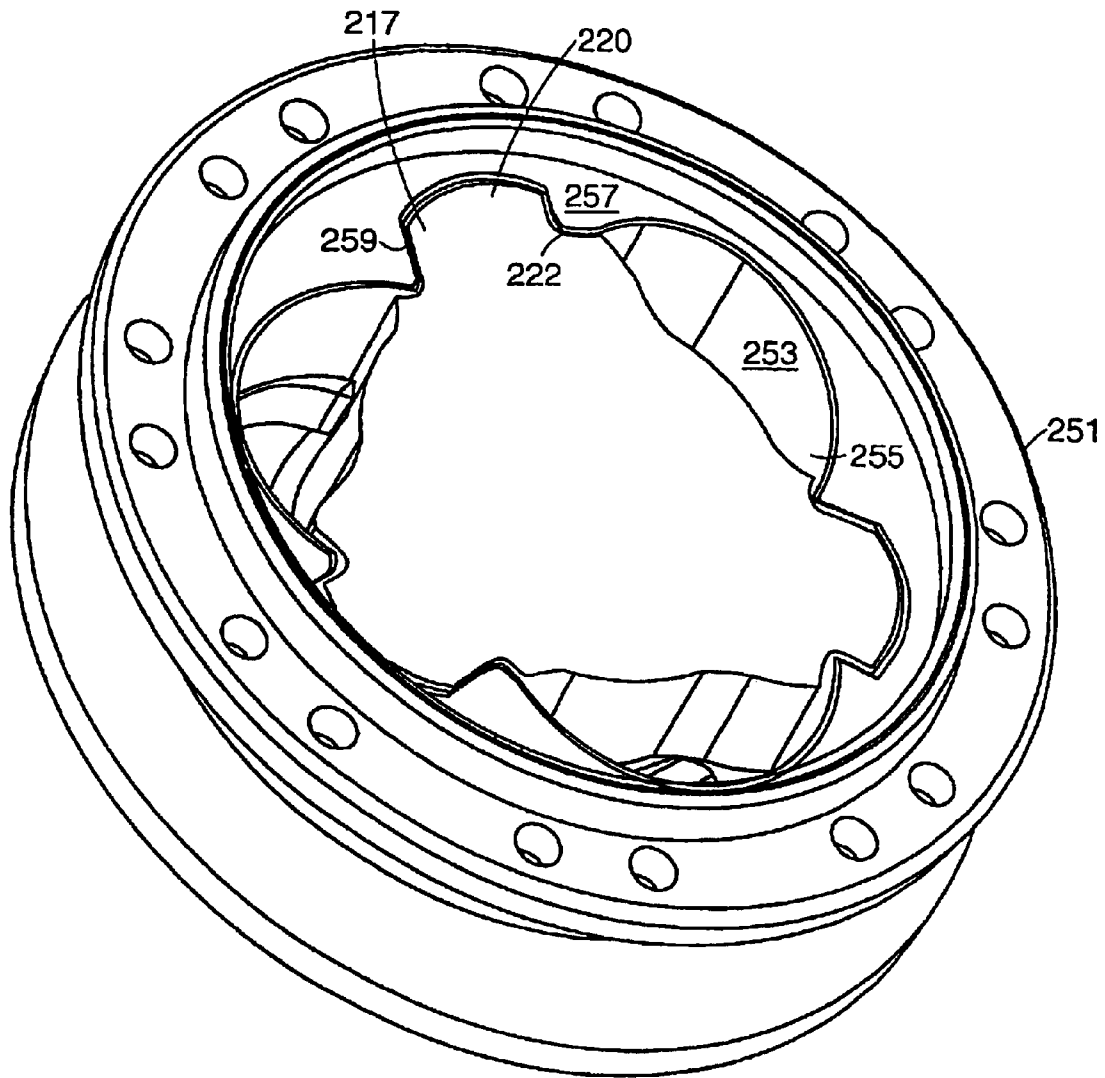

FIG. 24



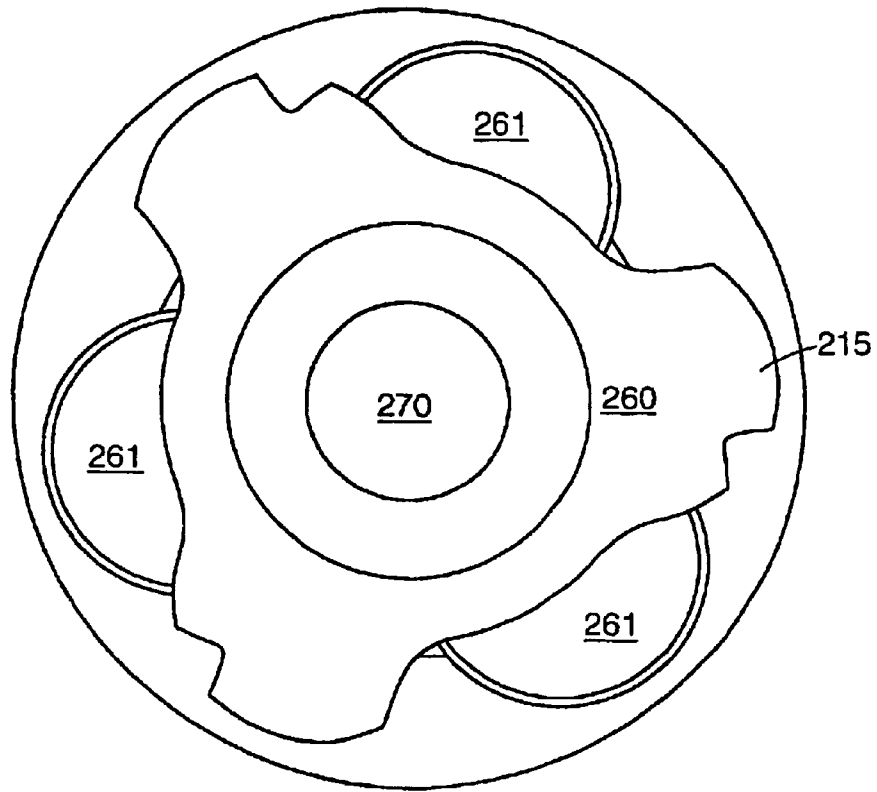

FIG. 25

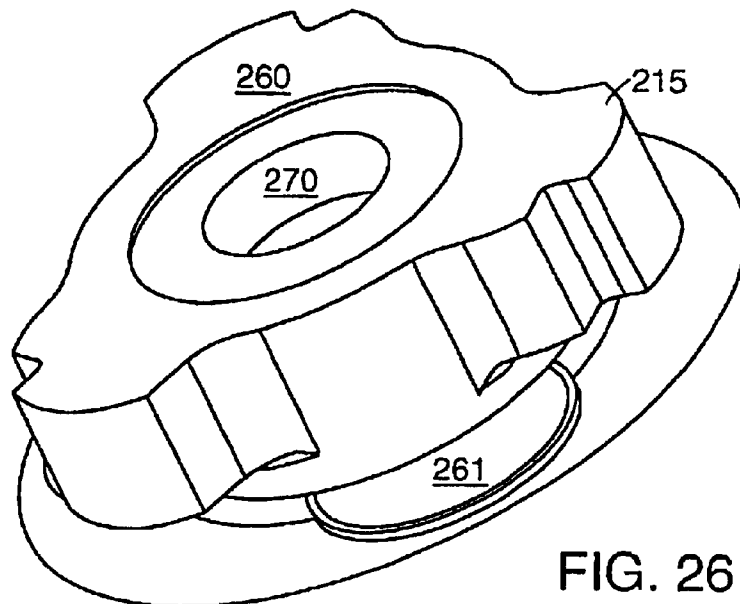

FIG. 26

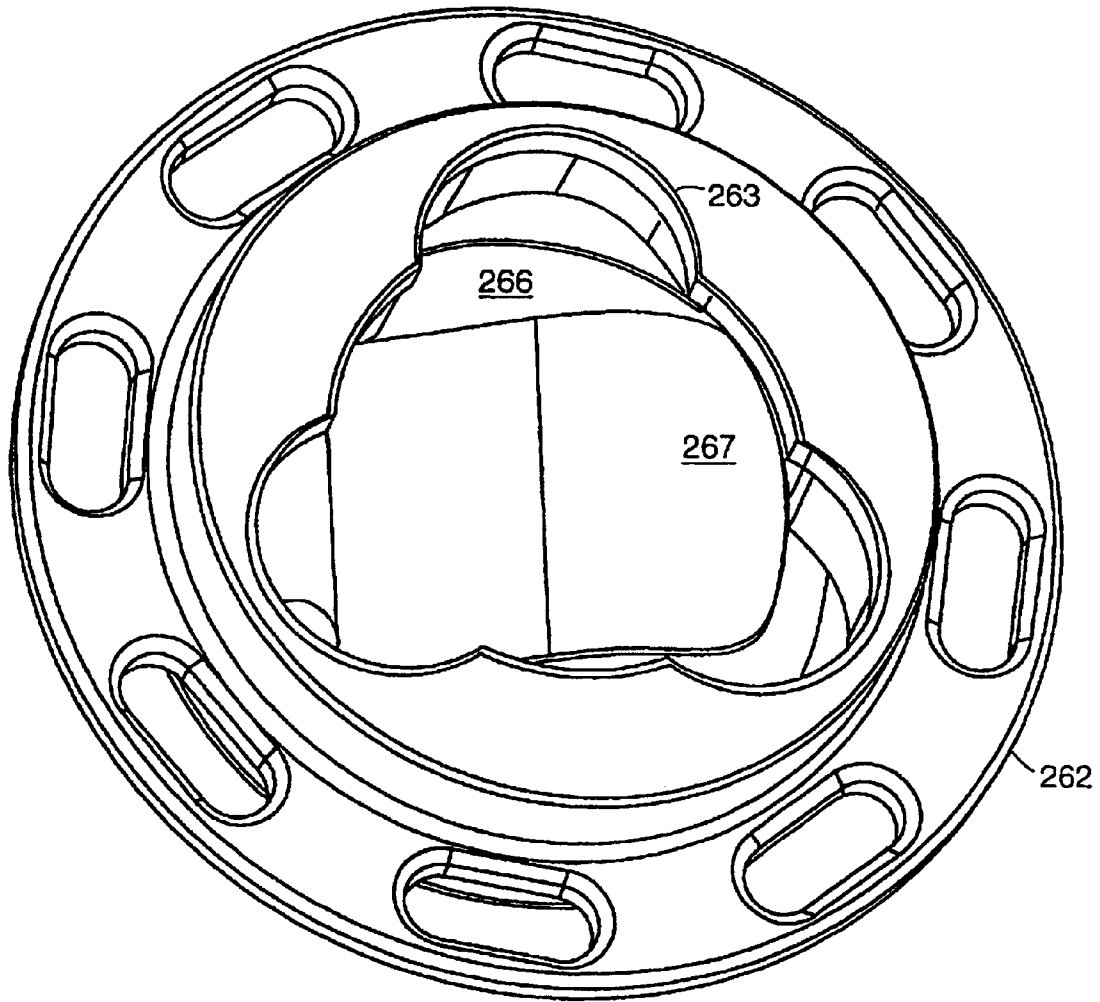

FIG. 27

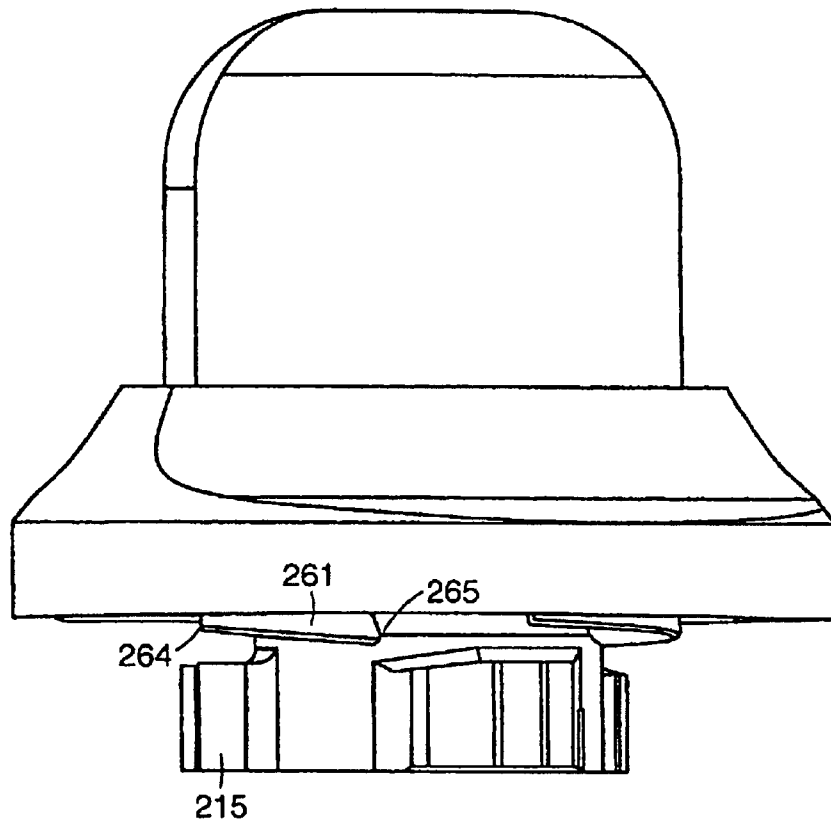

FIG. 28

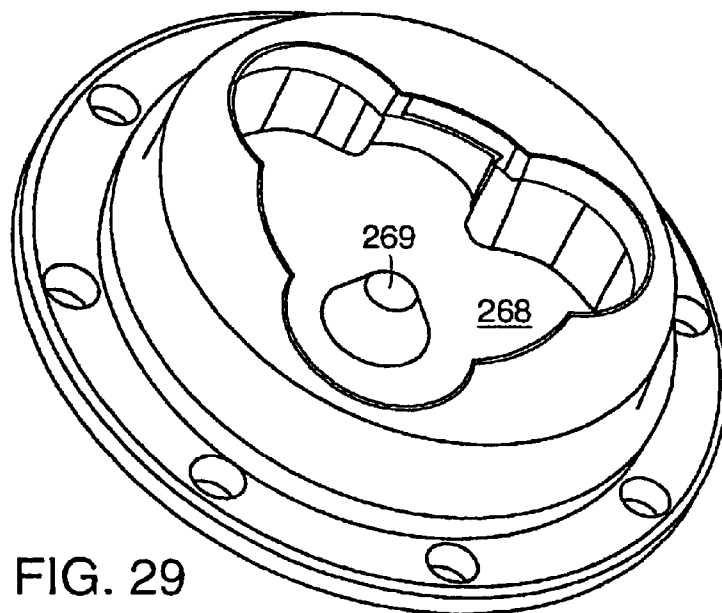

FIG. 29

## METHOD OF USING REMOVABLE CLEAT SYSTEM

**Matter enclosed in heavy brackets [ ] appears in the original patent but forms no part of this reissue specification; matter printed in italics indicates the additions made by reissue.**

*This is a continuation of application Ser. No. 09/641,117, filed on Aug. 17, 2000, which is a division of application Ser. No. 09/208,180, filed on Dec. 9, 1998, now U.S. Pat. No. 6,108,944, which is a continuation-in-part of application Ser. No. 09/062,037, filed on Apr. 17, 1998, now U.S. Pat. No. 6,151,805, which is a continuation-in-part of application Ser. No. 08/774,585, filed on Dec. 23, 1996, now U.S. Pat. No. 5,768,809.*

*Provisional application No. 60/010,099, filed on Jan. 17, 1996.*

### FIELD OF THE INVENTION

This invention relates to the mounting of traction gear on the bottom of footwear, in particular, athletic footwear.

### BACKGROUND ART

Conventional traction gear presently in use employ an attachment means consisting of screwing the traction gear into the mated receiving receptacle in the bottom of the footwear. Using this screw-type attachment method is especially laborious when one takes into account that a typical golf shoe, for instance, has eleven cleats; as a result, replacing the cleats on a pair of golf shoes entails unscrewing twenty-two cleats and screwing on twenty-two cleats, where each act of unscrewing or screwing entails several turns, typically two and one-half times, for each cleat.

An example of a typical prior-art cleat is in U.S. Pat. No. 4,723,366 (hereinafter the '366 (hereinafter the '366 cleat), which patent is incorporated herein by reference. This patent describes a cleat which includes a metal stud infrastructure at the core of the cleat, the infrastructure having a vertical axis and two ends, a screw portion at a first end for engagement with a receptacle within a shoe, a ground end for tractive engagement with the ground, and a broad flange between the screw and head portions and extending radially outward from the vertical axis; a plastic skirt is molded directly upon the flange portion to form a unitary reinforced radial support member of the cleat. Installation of the '366 cleat consists of screwing it into a mated receptacle in the bottom of athletic footwear.

Although some prior-art references show cleat-attachment systems that require less than a full turn, or they require a snap-on arrangement to lock the cleat in place, it appears none of these systems have found wide acceptance amongst users because of shortcomings in stability, ease-of-use, receptacle size and ease-of manufacture. For instance, in U.S. Pat. No. 4,633,600 to Dassler, a cleat attachment system is disclosed in which a snap ring socket is utilized to affix a cleat to the bottom of a shoe.

In U.S. Pat. No. 3,267,593 to Turner, a cleat attachment system is disclosed wherein the top of a cleat spike has two extensions forming a rough T-shape out of the spike, where the spike is inserted into a mated receptacle having two grooves to receive the extensions. Upon complete insertion of the spike into a receptacle, the spike is turned until the extensions drop into receiving grooves at the top of the receptacle; a retaining ring is then slid onto the mid-section of the spike, this ring apparently preventing the spike from unseating the extensions from the grooves.

Similarly, in German Patent Application Nos. DE3134817A1 to Sportartikelfabrik Karl Uhl GmbH, and DE3423363A1 to Gebrüder Goldschmidt Baubeschläge GmbH, another T-spike design is disclosed in which internal to the mated receptacle are ramping means for engaging and retaining the spike extensions. In the former, a rough interior surface catches the extensions, while in the latter, a sloping interior engages the extensions.

U.S. Pat. No. 4,492,047 to Arff, discloses another T-shape spike in which the skirt is deformed during insertion. Insertion of the spike causes the extensions to go up a ramp and then down a ramp, pulling the spike into the receptacle, and leaving the extensions in a holding area. The skirt is deformed so as to result in a pressure against the socket, the pressure apparently holding the spike from accidentally traveling back up the ramp towards removal.

In U.S. Pat. No. 4,035,934 to Hrivnak, another T-shape spike is disclosed in which the spike column has two indentations. During installation, two spring arms, each positioned perpendicular to the surface of the shoe and parallel to the spike, are pressed in during insertion of the spike, and spring back out to press against the indentations upon complete insertion. Removal of this spike is achieved with a U-shaped tool which slides into the spike receptacle and pushes in the spring arms, thus freeing the spike for removal.

### SUMMARY

A representative embodiment of the present invention includes a method of installing a removable cleat to the sole of a shoe. The method includes providing a cleat having (1) a ground-engaging structure for engaging the ground; and (2) an attachment structure for removably attaching the cleat to the footwear. The attachment structure has a vertical axis, a base to which the top of the ground-engaging member is attached, and a plurality of extensions attached to the base. A receptacle is provided for receiving and holding the cleat, the receptacle being mounted in the sole of a shoe. The receptacle has (1) a wall defining a cavity between a receptacle top and a receptacle bottom, wherein portions of the wall extend radially inward toward a central vertical axis of the receptacle so as to define: (i) a plurality of inclines within the cavity, and (ii) a plurality of protuberances within the cavity, each proturbence extending radially inward toward the vertical axis further than the compressible inclines; (2) a restraining ledge attached to the receptacle bottom and extending into the cavity so as to prevent downward movement of an installed cleat; and (3) an opening in the restraining ledge having at least three equi-distantly spaced radially projecting lobes that extend radially outward from the central vertical axis of the receptacle. The cleat extensions are inserted through the receptacle opening into the receptacle cavity. Then, the extensions are engaged above the restraining ledges so that the cleat is securely attached to the receptacle so as to resist rotational movement of the cleat.

In a further embodiment, each cleat extension may have a radial end and an angled indentation located towards the radial end, and the act of engaging may include engaging each angled indentation with an incline. The plurality of cleat extensions may be equidistantly spaced. Also, the plurality of cleat extensions may lie in a plane perpendicular to the vertical axis of the attachment structure. The cleat may further include a skirt located between the top of the ground-engaging structure and the bottom of the attachment structure base, the skirt extending radially outward beyond the radial ends of the extensions so that when the cleat is attached to the receptacle, the skirt covers the opening in the restraining ledge.

The skirt may include a plurality of openings on the ground-engaging structure side of the skirt so that a cleat wrench may be inserted into the skirt openings to maneuver the cleat. Each incline may have a relatively gradual front ascent portion and a relatively steep back descent portion. Engaging the extensions may include securing each extension between an incline and a protuberance so as to resist rotational movement of the cleat.

Another representative embodiment includes a removable cleat for a shoe. The cleat includes a ground-engaging structure for engaging the ground; and an attachment structure for removably attaching the cleat to the footwear. The attachment structure has a vertical axis, a base to which the top of the ground-engaging member is attached, and a plurality of extensions projecting radially outward from the base. The extensions are adapted for insertion into a cleat receptacle in the shoe to engage a receptacle attachment structure within the receptacle, so that when the cleat is attached to the receptacle, each cleat extension will be securely engaged above a receptacle restraining ledge.

In a further such embodiment, the attachment structure engaged by the cleat extensions includes an incline and a protuberance for each cleat extension, arranged so that when the cleat is attached to the receptacle, each cleat extension is secured between an incline and a protuberance so as to resist rotational movement of the cleat. Each incline may include a relatively gradual front ascent portion and a relatively steep back descent portion. Each protuberance may extend radially inward toward the vertical axis of the attachment structure further than the compressible incline. Each extension may have a radial end and an angled indentation located towards the radial end, the angled indentation being adapted to engage a corresponding incline when the cleat is attached to the receptacle.

The plurality of cleat extensions may be equidistantly spaced. The plurality of cleat extensions may lie in a plane perpendicular to the vertical axis of the attachment structure. The cleat may further include a skirt located between the top of the ground-engaging structure and the bottom of the attachment structure base, the skirt extending radially outward beyond the radial ends of the extensions so that when the cleat is attached to the receptacle, the skirt covers the receptacle.

The skirt may have a plurality of openings on the ground-engaging structure side of the skirt so that a cleat wrench may be inserted into the skirt openings to maneuver the cleat.

#### BRIEF DESCRIPTION OF THE DRAWINGS

The following drawings are intended to provide a better understanding of the present invention, but they are in no way intended to limit the scope of the invention.

FIG. 1 is a side view of a cleat according to one embodiment of the invention.

FIG. 2 is a top view of the cleat of FIG. 1, showing the shape of the lobes to be inserted into a mated receptacle in the bottom of athletic footwear.

FIG. 3 is another side view of the cleat of FIG. 1.

FIG. 4 is a bottom view of the cleat of FIG. 1.

FIG. 5 is a bottom view of a receptacle that may receive the FIG. 1 cleat.

FIG. 6 is a top section view of the FIG. 5 receptacle wherein the top layer of the receptacle has been removed.

FIG. 7 is a side vertical section of the receptacle of FIG. 6.

FIG. 8 is a top view of the FIG. 6 receptacle wherein the top layer has not been removed.

FIG. 9A is a perspective right side view of a cleat according to a preferred embodiment of the invention.

FIG. 9B is a perspective top view of the FIG. 9A cleat.

FIG. 9C is a perspective front view of the FIG. 9A cleat.

FIG. 9D is a perspective left view of the FIG. 9A cleat.

FIG. 10 is a top view of the cleat of FIG. 9A, showing the shape of the lobes to be inserted into a mated receptacle in the bottom of athletic footwear.

FIG. 11 is another side view of the cleat of FIG. 9A.

FIG. 12A is a top section view of a the receptacle for receiving the cleat of FIG. 9A, wherein the top layer off the receptacle has been removed.

FIG. 12B is a perspective bottom view of the FIG. 12A receptacle.

FIG. 13 is a side vertical section of the receptacle of FIG. 12A.

FIG. 14 is a bottom view of a cover for the FIG. 12A receptacle.

FIG. 15 is a side view of FIG. 14 cover.

FIG. 16 is a partial view of a FIG. 9A cleat inserted into a FIG. 12A receptacle.

FIG. 17 is a bottom view of the FIG. 9A receptacle.

FIG. 18 is a top view of an unassembled receptacle for receiving the FIG. 9A cleat.

FIG. 19 is a bottom view of the FIG. 18 receptacle.

FIG. 20 is a section view of the FIG. 18 receptacle.

FIG. 21 is a side view of a cleat according to a preferred embodiment of the invention.

FIG. 22 is a side view of a cleat according to a preferred embodiment of the invention showing an alternative ground-engaging "soft" golf spike.

FIG. 23 is a top view of a cleat similar to FIG. 21 showing the top of the cleat connector.

FIG. 24 is a perspective top view of the cleat of FIG. 21 in a receptacle with the top cover removed.

FIG. 25 is a top view of a cleat connector of the type shown in FIG. 23, with the addition of semi-circular dust covers.

FIG. 26 is a perspective top view of the cleat connector of FIG. 25.

FIG. 27 is a perspective bottom view of a preferred embodiment of a receptacle for receiving the cleat connector of FIG. 25.

FIG. 28 is an inverted side view of a cleat using the cleat connector of FIG. 25.

FIG. 29 is a perspective bottom view of an alternative receptacle having a center cone in the top cover.

#### DETAILED DESCRIPTION

The invention comprises a system for allowing the quick attachment and release of a wide variety of traction gear. FIG. 1 shows that in one embodiment of the invention, the attachment system would be used to attach cleats, such as those disclosed in U.S. Pat. No. 4,723,366, to the underside of athletic footwear a cleat installed in the bottom of a shoe using the present invention, when viewed from the bottom, has a similar appearance to the preferred embodiment of the invention disclosed herein. Evident in FIG. 1 are the bottom side 17 and top side 16 of the plastic skirt 15, the ground-engaging head portion 10 of the cleat, a base 13 to which the plastic skirt and ground-engaging portion are attached and a retaining member 20, which in this case is a base 13 with

5

three rounded extensions 22, all of which are positioned around a central axis 28. In a preferred embodiment of the invention, the top 16 of the skirt 15 is slightly concave, and the bottom 17 of the skirt 15 is somewhat convex.

FIG. 2 shows the topside 16 of the cleat skirt 15 and the retaining member 20, which has a roughly triangular shape with indentations 26. The extensions 22 of the retaining member 20 are used in conjunction with components inside the receptacle, shown as item 30 in FIG. 5, for locking in place a properly inserted retaining member 20. Locking in place occurs after inserting the retaining member 20 into a mated receptacle opening 40 as shown in FIG. 5 and FIG. 6, and torquing the retaining member. The extensions 22 are attached to the base 13 (shown in FIG. 1), and together the extensions and the base form the retaining member 20. In a preferred embodiment of the invention, a completed cleat, comprising the retaining member 20 and traction gear, is made out of plastic with a metal core used to reinforce the structure. Although the invention could be made entirely out of metal, it is preferable that the cleat be made partially of plastic and partially of metal. When the retaining member is plastic, the retaining member may be integrally formed with a plastic skirt of a golf cleat with a core, preferably metal, extending through the retaining member and the traction gear to form the ground-engaging head portion 10 shown in FIG. 1.

In a preferred embodiment of the invention, upon insertion of the retaining member 20 into a receptacle, the angled surface 24 (shown in FIG. 1) of the extensions 22 allows for a tighter fit of the retaining member 20 into the receptacle 40 (shown in FIG. 5). The tight connection not only serves to give a stable connection between the shoe and traction gear, but also serves to keep moisture and debris out of the attachment system.

FIG. 3 is another view showing the structure and proportion of the retaining member 20 as attached to traction gear 21. FIGS. 2 and 3 show that in a preferred embodiment of the invention, the extension 22 form a broad retaining member 20, and the base 13 is cylindrical and concentrically disposed around the center axis 28; the base 13 is attached to the extensions 22 and the traction gear 21.

FIG. 4, a bottom view of the FIG. 1 cleat, shows that, in a preferred embodiment of the invention, cleats do not have to be redesigned beyond modifying the retaining member 20 (shown in FIG. 1), and that conventional cleat designs are intended to be used in conjunction with the new retaining member; once a cleat is installed, the change in the retaining system is not apparent. A standard golf-cleat wrench may be used to engage the traction gear through use of the wrench holes 18.

FIG. 5 is a bottom view of a receptacle 30 that may receive the FIG. 1 cleat, showing the receptacle opening 40, with indentations 44 along its perimeter for accepting the retaining member extensions 22 (shown in FIG. 1). FIG. 5 also shows the ledges 46 that while serving to form the shape of the opening 40, also serve to hold the extensions 22 within the receptacle. Although preferred embodiments of the invention include a single receptacle opening 40, alternate embodiments of the system could have a receptacle with separate openings for receiving extensions.

FIG. 6 is a section view of FIG. 5 where the top layer of the receptacle has been removed to show the inner-cavity structure for receiving the retaining member 20 (shown in FIG. 1). Within the cavity, formed all wall portion 50, there are several cantilevered fingers 51, or spring arms, that are designed to grip and hold an installed retaining member.

6

When a retaining member is inserted into the indentations 44 and twisted, the twisting action causes a protruding edge of an extension 22 (shown in FIG. 1) to push into and bend the finger 51 to allow the extension to be turned past the location of the finger. Once the protruding edge of an extension passes the location of the finger, the finger springs back to nearly its original shape, so that surface 53 rests against the perimeter of the extension 22. This allows the cleat to be removed, but only be exerting sufficient force to bend the finger 51 away from the surface of the extension 22, an arrangement requiring much greater torque than that required during installation of the retaining member. In one embodiment, the fingers are elongated in shape, with surface 53 forming a curved tip to the finger. FIG. 6 also shows bumps 55 which serve as a means for preventing a retaining member from being turned too far. In a preferred embodiment, the cleat should not be turned more than about 60°. Coincident with the fingers 51 locking into place, the protruding edge of an extension is blocked from further movement by the bumps 55, and the entire retaining system is prevented from falling out of the receptacle by ledges 46. FIG. 6 also shows one method of attaching the receptacle to the underside of footwear by the use of mounting holes 57.

Spacing within the receptacle may be designed such that during installation of a cleat, the cavity 40 in which the extension is turned gradually narrows to compress and securely hold the cleat in place. Preferably the spacing is consistent or more gradual than the angled surface, so that the angled surfaces 24 (shown in FIG. 1) of the extension 22 being pressed against the ledges 46 cause the fit to be tight. In addition, having three extensions parallel to the cleat skirt makes for a more secure, base for a cleat.

FIG. 7 is a vertical section of a portion of the embodiment of the receptacle of FIG. 6. This view shows the ledge 46 formed by the bottom layer 45 of the receptacle and the wall portion 50 that defines the cavity within the receptacle. This view also shows the slight rise 48 which forms a lip at the receptacle opening so that the edge of an installed cleat's skirt may overlap the lip. The lip helps hold the cleat in place and makes it more resistant to lateral forces while the cleat is in use.

FIG. 8, which is the FIG. 6 receptacle where the top layer has not been removed, is a view from the top of the receptacle 30 in accordance with a preferred embodiment of the invention. This view shows the top side 67 of the mounting holes for attaching the receptacle.

FIGS. 9A-9D, 10 and 11 show a preferred embodiment of a cleat having the same basic characteristics and structural concerns of the FIGS. 1, 2, and 3 embodiments discussed herein above. Evident in FIG. 9A are the bottom side 17b and top side 16b of the plastic skirt 15b, the ground-engaging head portion 10b of the cleat, a base 13b to which the plastic skirt and ground-engaging portion are attached and a retaining member 20b, which in this case is a base 13b with three rounded extensions 22b, the extensions having an angled surface 24b and being positioned around a central axis 28b. FIGS. 9B-9D are respectively the perspective top, front, and left view of the FIG. 9A cleat.

Evident in FIG. 10 are the corresponding topside 16b of the cleat skirt 15b and the retaining member 20b, with indentations 26b. The extensions 22b of the retaining member 20b are used in conjunction with components inside the receptacle 84 of FIG. 12A, for locking in place a properly inserted retaining member 20b. Locking in place occurs after inserting the retaining member 20b into a mated receptacle opening 40b shown in FIG. 12A, and torquing the retaining

member. As with the FIG. 1 embodiment, upon inserting the retaining member 20b into a receptacle 84, the angled surface 24b (shown in FIG. 9A) of the extensions 22b forces a gradual compression of the retaining member 20b as it is inserted into the receptacle cavity 40b, resulting in a tight connection giving stability while also serving to keep moisture and debris out of the attachment system.

Also evident in the FIG. 10 embodiment is a modification to the FIG. 2 embodiment, where the extensions 22 of FIG. 2 are modified to include an indentation 70 that further enhances the invention's resistivity to unlocking and its unintentional removal through normal use. Increased resistivity is effected by an interlocking of a cantilevered finger 74 (shown in FIG. 16) with the indentation 70. The cantilevered finger 74 corresponds to the cantilevered finger 51 of the FIG. 6 embodiment, in which the cantilevered finger 51 has been thickened to afford a greater resistivity to unintentional unlocking. Further, upon complete insertion of the retaining member 20b into an appropriate receptacle 84 (shown in FIG. 12A), the end portion 90 of the cantilevered finger 74 rests within the indentation 70. Consequently, removal of the cleat requires greater torque than that required to install the cleat.

FIG. 11 is another view showing the structure and proportion of the retaining member 20b as attached to traction gear 21b, indicating the location of indentation 70, as well as showing that the placement of the retaining member 20b and base 13b is concentrically disposed around the center axis 28b.

FIG. 12A is a section view of a preferred embodiment of a receptacle for receiving the cleat of FIGS. 9A-9D, 10 and 11, where the top layer of the receptacle 84 has been removed to show the inner-cavity structure for receiving the retaining member 20b (shown in FIG. 9A). FIG. 12B shows a perspective view of the FIG. 12A receptacle. As with the FIG. 6 embodiment, included within the cavity, formed by wall portion 78, are several cantilevered fingers 74 designed to grip and hold an installed retaining member 20b. When a retaining member is inserted and twisted, the twisting action causes a protruding edge of an extension 22b to push into and bend the finger 74 to allow the extension to be turned past the location of the finger. Once the protruding edge of an extension passes the location of the finger 74, the finger springs back to nearly its original shape, so that surface 90 contacts the perimeter of the extension 22b. As described herein above, when the surface 90 contacts extension 22b, there is an interlocking of cantilevered finger 74 with the indentation 70 (shown in FIG. 10). This allows the cleat to be removed, but only by exerting sufficient force to disengage and bend finger 74 away from indentation 70 and the surface of the extension 22b, an arrangement requiring much greater torque than that required during installation of the retaining member. As with the FIG. 6 embodiment, the fingers are preferably elongated in shape, surface 90 forms a curved tip to the finger, and bumps 55b serve as a means for preventing a retaining member from being turned too far during insertion.

Also evident in the FIG. 12A receptacle is another preferred embodiment for attaching the receptacle 84 to the underside of footwear by the use of a mounting slot 80. In this embodiment, the perimeter 100 of the receptacle 84 comprises three flanges disposed around the receptacle opening 40b. In preferred embodiments, within each flange 82 of the perimeter are two slots 80 for mounting the receptacle 84 to footwear. Mounting of the receptacle is by methods known in the prior art, and may include forming sole material around the slots, or inserting a pin or other object

through the slot to effectively nail the receptacle to an inner-sole of a shoe, and then forming the outer-sole material around the receptacle so affixed. The slots 80 are separated by a pre-determined distance and are preferably curved to conform to the curvature of the flange 82 in which the slot 80 is set. Also shown are three openings 88 to allow for attaching a receptacle cover 96 (shown in FIG. 14) to the receptacle 84.

FIG. 13 is a vertical section of a portion of the embodiment of the receptacle of FIG. 12A. The FIG. 13 embodiment has a ridge 76 has been added in the bottom layer 86 of the wall portion 78 of the receptacle. In this preferred embodiment, the ridge 76 is located upon the downward side of the receptacle and helps assure mold seal-off. Sealing off the mold helps prevent sole material from the outsole molding process from accidentally spilling in over the bottom-end of the receptacle during production. (The receptacle and outsole are preferably molded ground-side up.) In addition, by adding ridge 76 to the basic design of FIG. 6, the structure of the FIG. 6 receptacle is strengthened, making it less susceptible to torques, distortions, or other forces. This results in better retention of the receptacle within the sole of athletic footwear.

FIG. 14 shows a receptacle cover 96 having three holes 92 corresponding to the three openings 88 shown in FIG. 12. In preferred embodiments, the receptacle cover is designed to attach to and seal the top end of the receptacle 84 of FIG. 12A, so that during molding of a shoe sole around the receptacle, the sole material does not seep under the top edge of the receptacle and fill its cavity. In addition, at the center of the cover 96 is a dome 94. This dome hangs downward from the top of the receptacle, into the receptacle cavity for receiving a retaining member 20b (shown in FIG. 9A).

FIG. 15 shows a side view of the FIG. 14 cover, indicating the extent of the dome 94 with respect to the rest of the cover's proportions. The dome forms a cavity 98 between a sole of a shoe and the top of the receptacle 84 (shown in FIG. 12A). In preferred embodiments, during manufacture of a shoe sole, in addition to sole material being molded around the receptacles, sole material is also allowed to fill in the cavity 98. Consequently, as a retaining member 20b (shown in FIG. 9A) is inserted into a proper receptacle, the insertion forces a compression of the dome which in turn compresses the sole material filling the dome. The dome 94 serves two purposes. First, when the retaining member 20b of traction gear is fully installed within a receptacle 84 (shown in FIG. 12A), the compression of the dome results in a downward pressure upon the extension 22b from the dome trying to reexpand into its original shape. Second, when one tries to remove the traction gear from the receptacle 84, the re-expansion of the sole material helps push the retaining member away from the sole, thus aiding in the removal of attached gear.

In preferred embodiments, the extensions for the attachment system are molded using conventional molding processes. Preferably, the molding-process uses mold components having expandable cavities, these cavities allowing for undercuts to be molded without the use of side actions or slides. The receptacle may be molded using conventional molding processes, where the receptacles are preferably produced on a horizontal or vertical press and, with the aid of precision mold design and building, are formed in a manner wellknown in the art.

In preferred embodiments of the invention, during manufacture, the receptacle portion with the top cover attached is placed in an outsole mold, and the ground surface

part of a shoe is then molded. The molding process is preferably one of injection or compression molding. The particular location of each receptacle within the mold depends on the intended use of the shoe and the design of the shoe's shape. During manufacture of the outsole of one embodiment of the invention, mold support-braces may be used to help ensure no deformation of the receptacles during the molding of the sole. Preferably, the support-braces are negatives of the receptacle's shape such that when a brace is inserted into a receptacle, the receptacle **84** and pin holes **88** (shown in FIG. **12A**) are temporarily sealed off to prevent sole material from filling in the receptacle cavity **40b** and pin holes **88**. These pins may also be used to help orient and position the receptacle so that sole material flows up to and not beyond the ridge **76** (shown in FIG. **13**) that is visible on the ground side of the receptacle. Once the outsole is molded, a second material may be molded or cemented to the outsole, and also cemented to the upper portion of the shoe. In this embodiment, the outsole and second material combination form a completed sole having the embedded receptacles.

In some embodiments, the shoe sole may be formed of light-weight materials such as EVA or foam. In such embodiments, the sole material may be insufficiently strong to hold a receptacle firmly in place. Consequently, in preferred embodiments, a support plate may be added to the sole structure, wherein the receptacles are attached to the plate at the desired locations, and the sole is formed around the attached receptacles. Such plates may also be used for heel support for footwear having light-weight heels; similarly, for heel-plates, support-pins may also be used to help-prevent heel receptacle deformation.

FIG. **16** is a partial view of a FIG. **9A** cleat inserted into a FIG. **12A** receptacle. Shown is a magnified view of the tip **90** of a cantilevered finger **74** at rest in indentation **70** of retaining member **20b**. As described herein above, after installation of a cleat into a receptacle, the torque required to dislodge the cantilevered finger **74** from the indentation **70** is much greater than that required during installation.

FIG. **17**, a bottom view of the FIG. **9A** cleat, shows that in this embodiment of the invention, a three-pronged wrench is inserted into the three wrench holes **110** used to remove the cleat. Use of a three-wrench-hole design gives greater stability during insertion and removal of a cleat, and allows greater torque to be applied, without slipping out of the holes, during such insertion and removal.

FIG. **18** is a top view of an alternate embodiment where a modified FIG. **14** cover is attached to the FIG. **12A** receptacle through a flexible attachment region **120**. In this embodiment, the receptacle **84** and cover **96** may be integrally formed of a single portion of production material, and simultaneously formed from a single mold. Before insertion of this embodiment of the receptacle into a shoe sole, the cover is flipped closed to cover the top of the receptacle. The FIG. **14** cover is modified to include two cover flanges **122** which, when the cover is closed, rest in-between two of the receptacle flanges **82**. The cover flanges **122** also have slots **124**, which in addition to the receptacle slots **80** described herein above, are used for mounting the FIG. **18** combined receptacle and cover to the underside of footwear.

FIG. **19** is a bottom view of the FIG. **18** embodiment, showing the ridge **76** (see FIG. **13** herein above) which helps prevent sole material from the outsole molding process from accidentally spilling in over the bottom-end of the receptacle opening **40b** with attached FIG. **14** cover having the features as disclosed herein above for FIG. **12A** and FIG. **14**.

FIG. **20** is a top section view of FIG. **18**, showing the relationship between the extent of the dome **94** and the

receptacle **84**. Also shown is the region defined by portions **126**, **128** for receiving the cover flange **122** when the cover is closed over the receptacle **84**.

FIG. **21** shows a side view of an alternative embodiment of a cleat having some of the same basic characteristics of the FIGS. **1**, **2**, and **3** embodiments discussed herein above. Evident in FIG. **21** are a bottom **201** of a plastic skirt **203**, and a top **205** with receptacles **207** for a cleat wrench. The cleat also has a ground-engaging spike **209** and a base **211** to which the skirt **203** and the spike **209** are attached. FIG. **22** is a side view of another cleat with a cleat connector similar to FIG. **21** showing an alternative ground-engaging "soft" golf spike **225**. FIG. **23** is a top view of the cleat connector of the cleats in FIGS. **21** and **22** showing retaining member **213**, which in this case is the base **211** with three thermoplastic extensions **215** projecting radially outward in a direction perpendicular to a vertical axis **210** of the base **211** in FIG. **21**. Each extension **215** has a front side **217** approximately parallel to a radial midline **218** of the extension **215** and which extends from a radial end **220** of the extension **215** back towards the vertical axis **210** of the base **211**. Each extension **215** also has a back side **219**, roughly parallel to and substantially shorter than the front side **217**; the back side **219** is also closer to the midline **218** of the extension **215** than the front side **217**. The back side **219** extends back from the radial end of the extension **220**, partway to the base **210** until it joins another surface **221** which is substantially perpendicular to the radial midline of the extension **218**, so as to form an L-shaped indentation **222**. In a preferred embodiment, the extensions **215** all lie in the same plane, and each extension **215** is equidistant from the adjacent extension.

FIG. **24** is a perspective top view of a preferred embodiment of a receptacle **251** for receiving the cleats of FIGS. **21**, **22**, and **23** with the top cover removed to show the inner-cavity structure for receiving the retaining member, **213** in FIG. **23**. Within a cavity **253**, formed by wall portion **255**, are several protuberances **257** designed to grip and hold an installed retaining member **213**. When a retaining member **213** is inserted and twisted, the twisting action rotates the front side **217** of an extension **215** past a protuberance **257** so that the radial end **220** of the extension **215** compresses the protuberance **257**, allowing the extension **215** to turn past the protuberance **257**. The extension **215** can continue to rotate until the front side **217** of the extension **215** engages a stopping wall portion **259** of the cavity **253**. The receptacle **250** is designed so when the front side **217** of an extension **215** engages a stopping wall portion **259** of the cavity **253**, the protuberance **257** springs back to nearly its original shape and snugly engages the L-shaped indentation **222** on the back side **219** of the extension **215**. Each extension **215** of an installed cleat, therefore, is firmly held in place between a stopping wall **259** and a protuberance **257** so that the retaining member **213** is securely attached to the receptacle **250**.

Removal of the cleat requires rotation in the opposite direction from installation. In a preferred embodiment, the protuberances **257** and the radial ends **220** of the extensions **215** are shaped so that rotation of the cleat in the removing direction requires much greater torque than that required during installation. For example, the radial ends **220** of the extension **215** may be tapered on the front side, **223** in FIG. **23**, so that the radial end more easily rides over and compresses the protuberance during installation. Without a taper on the back side **224** of the radial end of the extension **215**, substantially greater force is required for the radial end **220** to ride over and compresses the protuberance **257** when rota-



tion is in the removing direction. Alternatively, the protuberances 257, rather than the extensions 215, may be tapered to allow easier rotation in the installation direction and require greater force for rotation in the removing direction.

FIG. 25 is a top view of a cleat connector 260 of the type shown in FIG. 23, with the addition of semi-circular dust covers 261 between each extension 215. Of course, the cleat connector 260 may be placed on top of a wide variety of surface engaging structures including both surface penetrating structures and non-surface penetrating structures. FIG. 26 is a perspective top view of the cleat connector 260 of FIG. 25, and FIG. 27 is a perspective top view of a preferred embodiment of a receptacle 262 for receiving the cleat connector 260 of FIG. 25. To install the cleat, the connector extensions 215 are inserted into the receptacle's semicircular openings 263. The cleat is rotated into place to engage the structure of the connector 260 with the internal structure of the receptacle 262 as described above with respect to FIGS. 23 and 24. This also rotates the dust covers 261 towards the receptacle openings 263. As the connector 260 locks into place in the receptacle 262, the dust covers 261 settle snugly into the receptacle openings 263 to seal the openings 263 so as to prevent the entry of debris from the ground into the receptacle 262.

As shown in FIG. 28, the dust covers 261 may have an incline so that as the connector 260 rotates into place in the receptacle 262, the leading edge 264 of the dust cover 261 is lower, or closer to the base of the connector 260 than is the trailing edge 265 of the dust cover 261. As a result, as the cleat is rotated, the dust cover 261 initially rotates easily over the opening 263 of the receptacle 262. Before the structure of the connector 260 locks into engagement with the internal structure of the receptacle 262, the higher trailing edge 265 of the dust cover 261 becomes compressed by the edge of the opening 263 of the receptacle 262 increasing the amount of force required to rotate the cleat. Just as the structure of the connector 260 locks into engagement with the internal structure of the receptacle 262, the trailing edge 265 of the dust cover 261 clears the edge of the opening 263 of the receptacle 262. This releases the compression of the trailing edge 265 of the dust cover 261 which springs down into the opening 263 of the receptacle 262. Thus, the vertical face of the trailing edge 265 of the dust cover 261 fits against the edge of the opening 263 of the receptacle 262 so as to form a secondary lock in addition to the primary lock of the structure of the connector 260 in engagement with the internal structure of the receptacle 262. In addition to sealing against the entry of debris into the receptacle 262, the secondary lock formed by, the dust covers 261 in engagement with the opening 263 of the receptacle 262, provides additional resistance against the undesired unlocking rotation of the installed cleat in high torque environments such as with baseball cleats.

FIG. 27 also shows a receptacle 262 with a receptacle cover 266 having a cover spring 267 which extends into a receptacle cavity defined by the receptacle openings 263. The receptacle spring 267 performs two functions similar to that of the dome 94 in FIGS. 14 and 15. First, when a cleat connector 260 is installed so as to engage the structure of the receptacle 262, the receptacle spring 267 is compressed and thereby exerts a downward pressure on the cleat connector 260 which increases the contacting force between the connector 260 and the receptacle 262. Second, when the cleat is rotated for removal from the receptacle 262 (e.g., for replacement), the receptacle spring supplies an ejecting force on the cleat connector 260 which aids in disengaging the cleat connector 260 from the receptacle 262.

These functions do not necessarily require the use of a dome 94 as in FIGS. 14 and 15, or a spring 267 as in FIG. 27. FIG. 29 shows a receptacle cover 268 having a center cone 269. The cone 269 performs the same function as the previously discussed dome 94 and spring 267. In addition, the size and strength of the cone 269 may be relatively substantial when the cleat connector 260 contains a similarly shaped mating depression 270, shown in FIGS. 25 and 26.

It should be realized that while the various preferred embodiments of cleat receptacles differ in the complexity of their specific structures, this does not significantly restrict the materials which may be used to fabricate such receptacles. All or part of a receptacle may be fabricated from metal. Alternatively, all or part of a receptacle may be fabricated from a synthetic material such as plastic or nylon. Metal offers great strength, but with relatively great weight. Synthetic materials may be relatively lighter, while somewhat less strong than metal. Either metal or synthetic materials may, however, be employed satisfactorily.

In the preceding description and following claims, the term "cleat" is consistently used, however, no distinction is intended to be created between cleats and spikes, nor should any be inferred. In addition, while preferred embodiments have been described in which a cleat may be removably attached to a shoe using the described connectors and receptacles, the use of such connectors and receptacles is not limited to attaching cleats to shoes, but may be generally employed as a removably attachable connector system in other applications which require the attachment of one mechanical structure to another. Similarly, it is of course apparent that the present invention is not limited to the detailed description set forth above. Various changes and modifications of this invention as described will be apparent to those skilled in the art without departing from the spirit and scope of this invention as defined in the following claims.

What is claimed is:

1. A method of installing a removable cleat to the sole of a shoe, the method comprising:
  - providing a cleat having:
    - a ground-engaging structure for engaging the ground; and
    - an attachment structure for removably attaching the cleat to the footwear, the attachment structure having a vertical axis, a base to which the top of the ground-engaging structure is attached, and a plurality of extensions attached to the base;
  - providing a receptacle for receiving and holding the cleat, the receptacle being mounted in the sole of a shoe, the receptacle having:
    - a wall defining a cavity between a receptacle top and a receptacle bottom, wherein portions of the wall extend radially inward toward a central vertical axis of the receptacle so as to define:
      - (i) a plurality of inclines within the cavity, and
      - (ii) a plurality of protuberances within the cavity, each protuberance extending radially inward toward the vertical axis further than the inclines;
    - a restraining ledge attached to the receptacle bottom and extending into the cavity so as to prevent downward movement of an installed cleat; and
    - an opening in the restraining ledge having at least three equidistantly spaced radially projecting lobes that extend radially outward from the central vertical axis of the receptacle; and
  - inserting the cleat extensions through the receptacle opening into the receptacle cavity; and

13

engaging the extensions above the restraining ledges so that the cleat is securely attached to the receptacle so as to resist rotational movement of the cleat.

2. A method according to claim 1, wherein each cleat extension has a radial end and an angled indentation located towards the radial end, and the act of engaging includes engaging each angled indentation with an incline.

3. A method according to claim 1, wherein the plurality of cleat extensions are equidistantly spaced.

4. A method according to claim 1, wherein the plurality of cleat extensions lie in a plane perpendicular to the vertical axis of the attachment structure.

5. A method according to claim 1, wherein the cleat further comprises a skirt located between the top of the ground-engaging structure and the bottom of the attachment structure base, the skirt extending radially outward beyond the radial ends of the extensions so that when the cleat is attached to the receptacle, the skirt covers the opening in the restraining ledge.

6. A method according to claim 5, wherein the skirt has a plurality of openings on the ground-engaging structure side of the skirt so that a cleat wrench may be inserted into the skirt openings to maneuver the cleat.

7. A method according to claim 1, wherein each incline has a relatively gradual front ascent portion and a relatively steep back descent portion.

8. A method according to claim 1, wherein engaging the extensions includes securing each extension between an incline and a protuberance so as to resist rotational movement of the cleat.

9. A removable cleat for a shoe comprising:

a ground-engaging structure for engaging the ground; and an attachment structure for removably attaching the ground-engaging structure to a cleat receptacle in a shoe, the receptacle including:

a wall defining a cavity between a receptacle top and a receptacle bottom, wherein portions of the wall extend radially inward toward a central vertical axis of the receptacle so as to define:

(i) a plurality of inclines within the cavity, and

(ii) a plurality of protuberances within the cavity, each protuberance extending radially inward toward the vertical axis further than the inclines;

a restraining ledge attached to the receptacle bottom and extending into the cavity so as to prevent downward movement of an installed cleat; and

an opening in the restraining ledge having at least three equidistantly spaced radially projecting lobes that extend radially outward from the vertical axis of the receptacle; and

wherein the attachment structure is adapted for secure attachment to the receptacle so as to resist rotational movement.

10. A removable cleat according to claim 9, wherein the attachment structure includes a plurality of cleat extensions arranged so that when the cleat is attached to the receptacle, each cleat extension is secured between an incline and a protuberance so as to resist rotational movement of the cleat.

11. A removable cleat according to claim 10, wherein each cleat extension has a radial end and an angled indentation located towards the radial end, the angled indentation being adapted to engage a corresponding incline when the cleat is attached to the receptacle.

12. A removable cleat according to claim 10, wherein the plurality of cleat extensions lie in a plane perpendicular to a vertical axis of the attachment structure.

13. A removable cleat according to claim 9, wherein the cleat further comprises a skirt located between the top of the

14

ground-engaging structure and the bottom of the attachment structure, the skirt extending radially outward so that when the cleat is attached to the receptacle, the skirt covers the receptacle.

14. A removable cleat according to claim 13, wherein the skirt has a plurality of openings on the ground-engaging structure side of the skirt so that a cleat wrench may be inserted into the skirt openings to maneuver the cleat.

15. An attachment system, comprising:

A. a receptacle, the receptacle having an opening and a member engaging structure including at least three receptacle projections; and

B. a member, rotationally attachable to the receptacle, having a vertical axis with first and second ends, including at the first end, an attachment structure including at least three member projections, each member projection having first and second ramps on corresponding first and second sides of an axis projecting radially outward from the center of the attachment structure through the circumferential center of the projection, each projection having a convex face, wherein each projection is asymmetric with respect to the axis.

16. A system according to claim 15, wherein the member is made substantially of thermoplastic.

17. A system according to claim 15, wherein the member projections and the receptacle projections interact in a plane substantially transverse to the vertical axis of the member.

18. A system according to claim 15, wherein the member rotates less than one-half full turn when engaging with the receptacle.

19. A system according to claim 15, wherein the member rotates less than one-half full turn when disengaging from the receptacle.

20. An attachment system according to claim 15 for footwear, wherein the member is a cleat, the system comprising:

A. a cleat receptacle, the receptacle having an opening and a cleat engaging structure including at least three receptacle projections; and

B. a rotationally attachable cleat having a vertical axis with first and second ends, including:

i. at the second end, a surface engaging member; and

ii. at the first end, an attachment structure including at least three cleat projections, each cleat projection having first and second ramps on corresponding first and second sides of an axis projecting radially outward from the center of the attachment structure through the circumferential center of the projection, each projection having a convex face, wherein each projection is asymmetric with respect to the axis.

21. A system according to claim 20, wherein the member projections interact with the receptacle projections so that less force is required to engage the cleat with the receptacle than to disengage the cleat from the receptacle.

22. A system according to claim 20, wherein the member is made substantially of thermoplastic.

23. A system according to claim 20, wherein the member projections and the receptacle projections interact in a plane substantially transverse to the vertical axis of the member.

24. A system according to claim 20, wherein the member rotates less than one-half full turn when engaging with the receptacle.

25. A system according to claim 20, wherein the member rotates less than one-half full turn when disengaging from the receptacle.

26. A system according to claim 20, wherein, as the member is installed into the receptacle, each member projection

15

has a rotationally leading edge and a rotationally trailing edge, each receptacle projection engaging the rotationally trailing edge of an installed member so as to resist loosening rotation of the cleat.

27. A rotationally attachable cleat for footwear having a vertical axis with first and second ends, the cleat comprising:

at the first end, a surface engaging member; and

at the second end, an attachment structure including at least three cleat projections, each cleat projection having first and second ramps on corresponding first and second sides of an axis projecting radially outward from the center of the attachment structure through the circumferential center of the projection, each projection having a convex face, wherein each projection is asymmetric with respect to the axis, wherein the cleat projections are capable of interacting with a corresponding cleat receptacle.

28. A cleat according to claim 27 wherein less force is required to engage the cleat with the receptacle than to disengage the cleat from the receptacle.

29. A cleat according to claim 27, wherein the cleat is made substantially of thermoplastic.

30. A cleat according to claim 27, wherein the cleat projections are capable of interacting with the receptacle in a plane substantially transverse to the vertical axis of the cleat.

31. A cleat according to claim 27, wherein the cleat rotates less than one-half full turn when engaging with the receptacle.

32. A cleat according to claim 27, wherein the cleat rotates less than one-half full turn when disengaging from the receptacle.

16

33. An attachment system, comprising:

A. a receptacle, the receptacle having an opening and a member engaging structure including at least three receptacle projections; and

B. a member, rotationally attachable to the receptacle, having a vertical axis with first and second ends, including at the first end, an attachment structure including at least three member projections, each member projection having first and second ramps on corresponding first and second sides of an axis projecting radially outward from the center of the attachment structure through the circumferential center of the projection, each projection having a convex face, wherein the first and second ramps of each member projection interact with a corresponding receptacle projection to resist rotation of the member relative to the receptacle.

34. A system according to claim 33, wherein the member is made substantially of thermoplastic.

35. A system according to claim 33, wherein the member projections and the receptacle projections interact in a plane substantially transverse to the vertical axis of the member.

36. A system according to claim 33, wherein the member rotates less than one-half full turn when engaging with the receptacle.

37. A system according to claim 33, wherein the member rotates less than one-half full turn when disengaging with the receptacle.

\* \* \* \* \*

UNITED STATES PATENT AND TRADEMARK OFFICE  
**CERTIFICATE OF CORRECTION**

PATENT NO. : RE 40,460 E  
APPLICATION NO. : 10/847811  
DATED : August 19, 2008  
INVENTOR(S) : Savoie

Page 1 of 1

It is certified that error appears in the above-identified patent and that said Letters Patent is hereby corrected as shown below:

COLUMN 13 LINE 35 **DELETE** "fop" **AND INSERT** --top--

Signed and Sealed this

Fourteenth Day of October, 2008

A handwritten signature in black ink that reads "Jon W. Dudas". The signature is written in a cursive style with a large, looped initial "J".

JON W. DUDAS  
*Director of the United States Patent and Trademark Office*