

G. D. BURTON & E. E. ANGELL.

ELECTRIC CONVERTER.

No. 522,507.

Patented July 3, 1894.

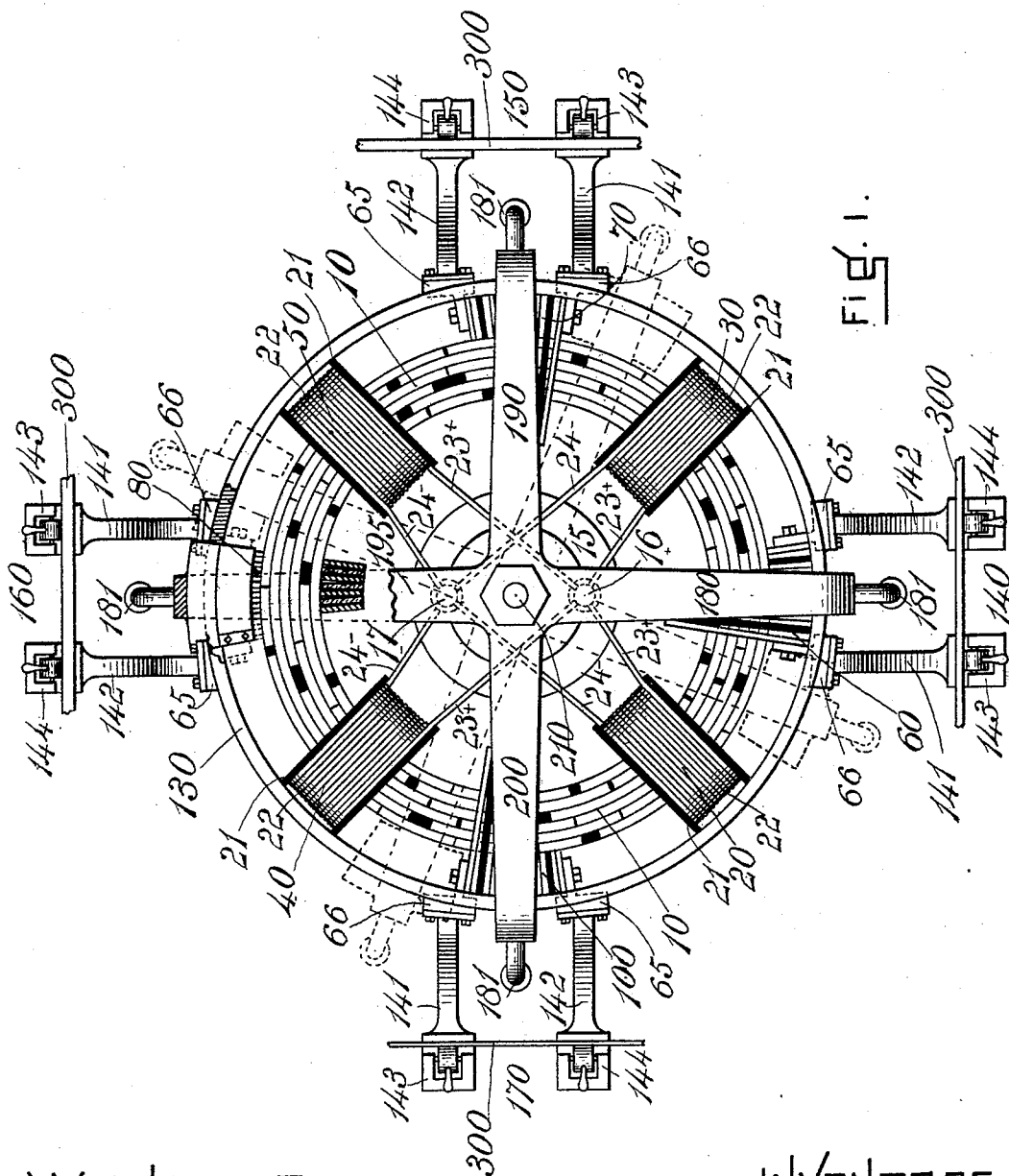

FIG. 1.

WITNESSES
 R. E. Somes.
 P. L. Webb.

INVENTORS
 G. D. Burton
 E. E. Angell,
 By J. C. Somes,
 Attorney.

G. D. BURTON & E. E. ANGELL.
ELECTRIC CONVERTER.

No. 522,507.

Patented July 3, 1894.

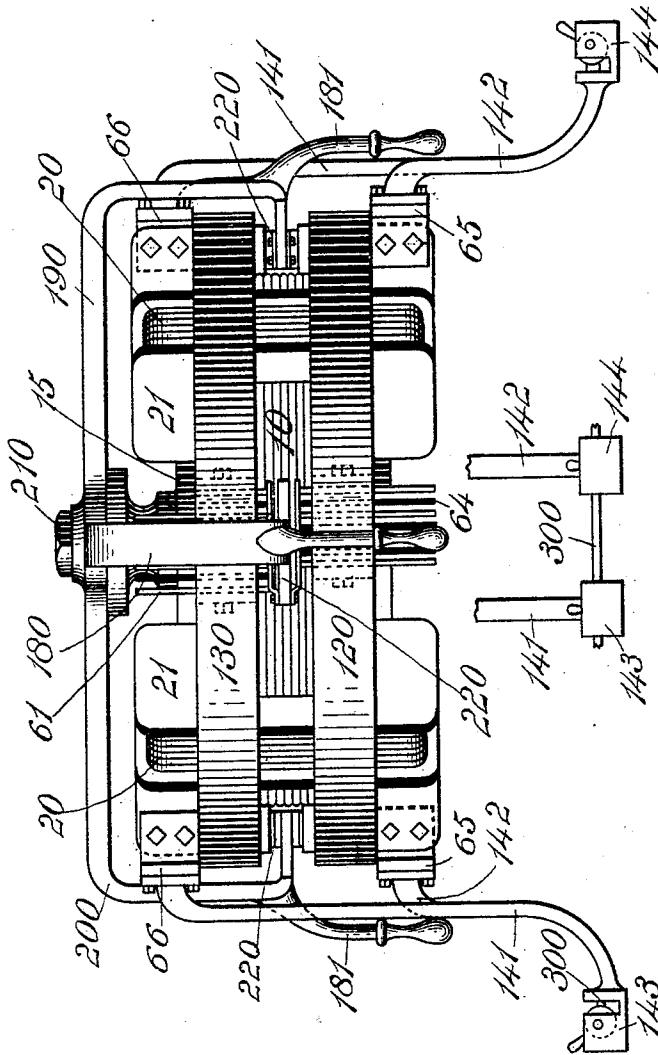

FIG. 2.

WITNESSES.

R. E. Somes.
P. L. Webb.

INVENTORS.

G. D. Burton
E. E. Angell
By J. C. Somes,
Attorney

G. D. BURTON & E. E. ANGELL.
ELECTRIC CONVERTER.

No. 522,507.

Patented July 3, 1894.

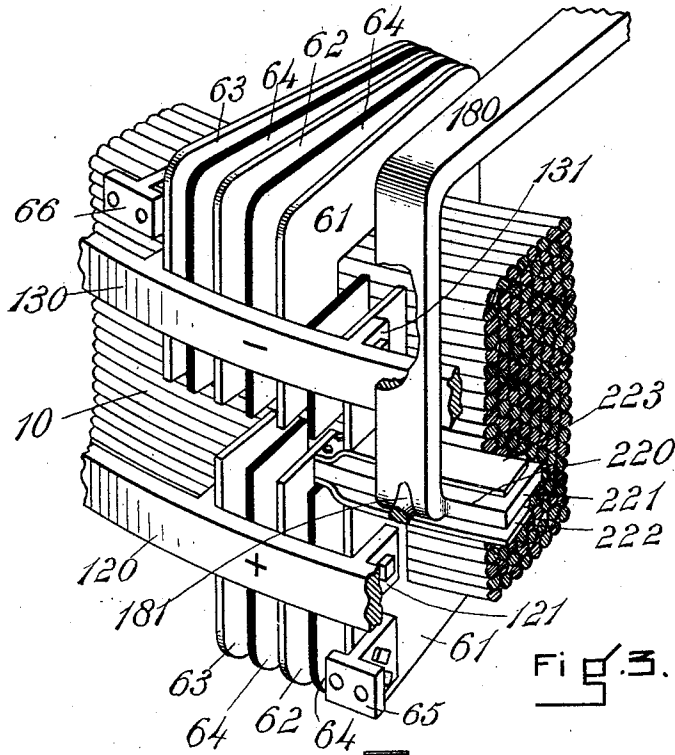

Fig. 3.

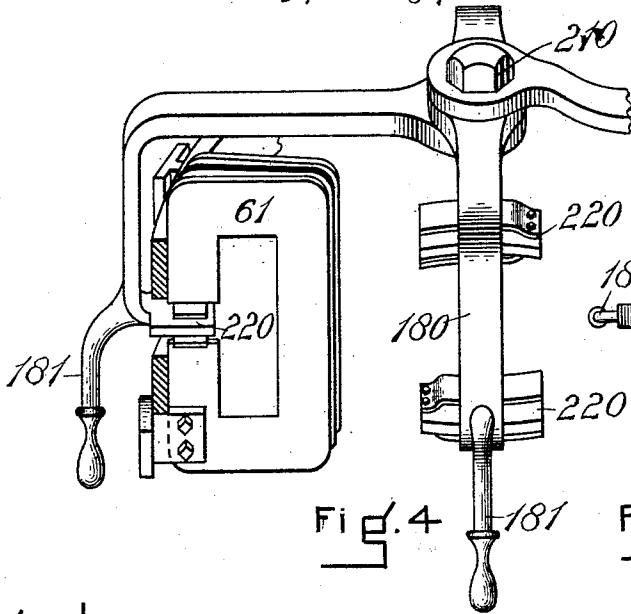

Fig. 4

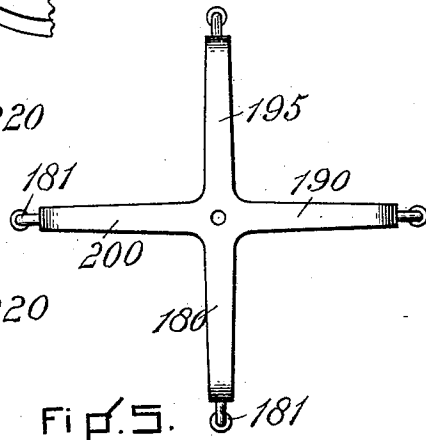

Fig. 5.

WITNESSES

R. E. Somes.
P. L. Webb.

INVENTORS.

G. D. Burton
E. E. Angell.
By J. C. Somes
Attorney.

G. D. BURTON & E. E. ANGELL.
ELECTRIC CONVERTER.

No. 522,507.

Patented July 3, 1894.

Fig. 6.

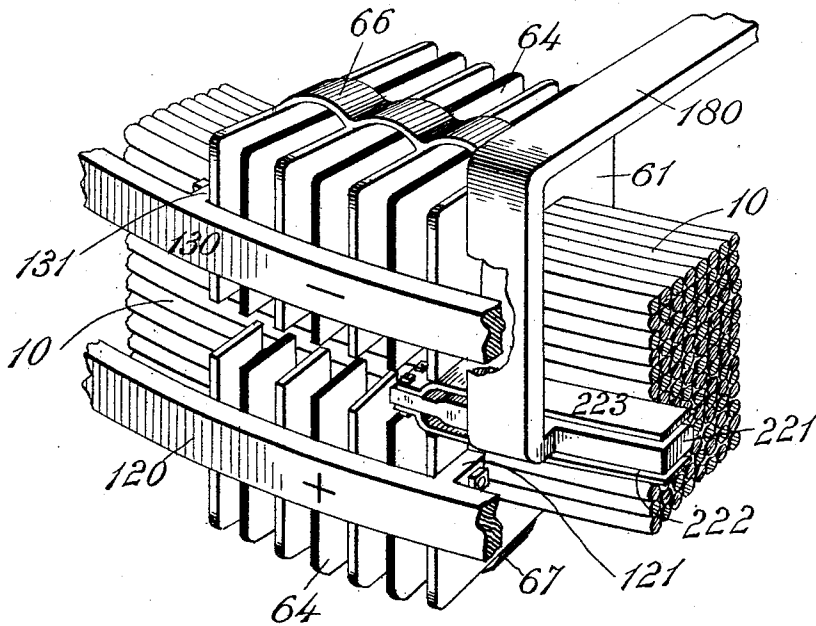
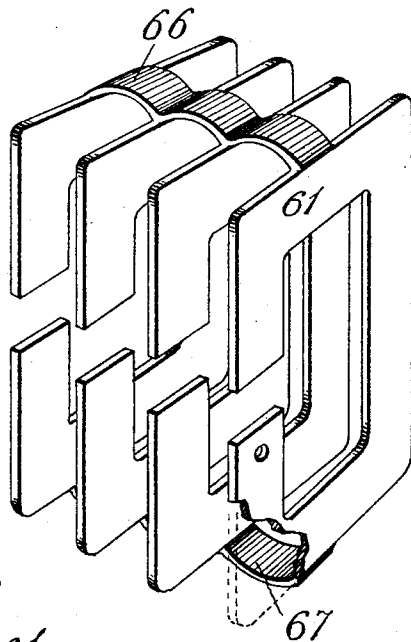

Fig. 7.



WITNESSES

R. E. Somes.
P. L. Holt.

INVENTORS:

G. D. Burton
E. E. Angell,
By J. C. Somes, Attorney

UNITED STATES PATENT OFFICE.

GEORGE D. BURTON, OF BOSTON, AND EDWIN E. ANGELL, OF SOMERVILLE,
MASSACHUSETTS, ASSIGNORS TO THE ELECTRICAL FORGING COMPANY,
OF MAINE.

ELECTRIC CONVERTER.

SPECIFICATION forming part of Letters Patent No. 522,507, dated July 3, 1894.

Application filed November 29, 1892. Serial No. 453,465. (No model.)

To all whom it may concern:

Be it known that we, GEORGE DEXTER BURTON, residing at Boston, in the county of Suffolk, and EDWIN ELLIOTT ANGELL, residing at Somerville, in the county of Middlesex, in the State of Massachusetts, citizens of the United States of America, have invented certain new and useful Improvements in Electric Transformers, of which the following is a specification.

This invention relates to an electric converter for transforming currents of high pressure and small volume into currents of low pressure and large volume for metal heating purposes.

The object of the invention is to provide a converter to which a number of electric forges are connected in parallel with means for regulating the secondary currents for the several forges either jointly or independently of each other, so that the workmen at the different forges can readily adapt the heating currents thereof to the size of the bars being heated.

The invention as herein illustrated enables four men to work at the same time at the same converter, each regulating his own secondary current to suit the size of the piece of metal he is heating; for instance, on one side the voltage and volume of the current may be adjusted to heat a piece twelve inches long and one inch in cross section, and pieces the same length and two, three and four inches in cross section may be heated in the other sides respectively.

Figure 1 of the accompanying drawings represents a plan view of this improved electric converter to which four electric forges are attached. Fig. 2 represents a side elevation thereof, portions of the front forge being omitted. Fig. 3 represents in perspective an enlarged segment of the converter. Fig. 4 represents on an enlarged scale a transverse section through a portion of the converter partly in perspective. Fig. 5 represents a plan view of the swiveled frame carrying brushes to throw into or out of circuit more or less turns or plates of the secondary coils for regulating the currents thereof. Fig. 6 represents on an enlarged scale a perspective view of a segment of the converter showing

a secondary coil composed of separated rings connected by bridges. Fig. 7 represents on an enlarged scale a perspective view of a casting comprising connected conductive plates of a secondary coil such as that shown in Fig. 6.

The same reference numbers are used in all the figures to represent the same parts.

The core 10 of this improved electric converter is of any suitable construction. It is preferably ring-shaped in form and composed of a number of pieces of soft iron wire uninsulated from each other and of different lengths arranged to break joints, similar to the core of the converter described in Letters Patent No. 475,232 to the Electrical Forging Company as assignee of Burton, Eddy and Briggs, dated May 17, 1892. The primary coils of this converter are also of any suitable construction.

The core herein shown is provided with four primary coils 20, 30, 40 and 50, each of which comprises a spool as 21, composed of insulating material and a winding as 22 of fine insulated copper wire, each coil having a positive terminal as 23 and a negative terminal as 24.

A central plate 15 has a binding post 16 which constitutes the primary positive terminal of the converter, and a binding post 17 constituting the primary negative terminal thereof. The positive terminals of the respective coils are connected with one of these binding posts and the negative terminals with the other. The secondary coils 60, 70, 80 and 100 are disposed on the core between the primary coils. Each of these secondary coils consists of two or more incomplete rings or C-shaped plates as 61, 62, and 63 disposed on the body of the core with their open sides outward. Insulators as 64 composed of fiber board, paper or other suitable material may be disposed on the core between the said rings or plates for insulating the latter from one another, and these plates are also insulated from the core by means of paper or other suitable insulating material. A lug, as 65, is attached to one end plate of each secondary coil, and constitutes the positive terminal thereof, and a similar lug, as 66, is attached to the opposite end plate of the same coil and constitutes

the negative terminal thereof. The plates of the secondary coils are preferably composed of copper.

A ring, 120, composed of copper, surrounds the converter on the exterior thereof and is provided with lugs 121 which are connected to the positive plates as 61 of each of the secondary coils and a similar copper ring 130 surrounds the converter on its exterior above the ring 120 and is provided with lugs 131 which are connected with the negative plates of each secondary coil. These rings touch the outer edges of the plates of the secondary coils and serve as conductors between them. The ring 120 may serve as the secondary positive pole of the converter and the ring 130 as the secondary negative pole thereof.

In the construction represented in Figs. 6 and 7 the several plates of the secondary coil are cast in one piece and connected by bridges, as 66, at their tops and bridges 67 at their bottoms. These bridges serve as conductors to pass the current from the first plate to the last plate or from any intervening plate to the last plate for connection with the negative pole of the coil.

Several electric forges as 140, 150, 160 and 170 are connected with the converter at different points on its circumference. Each of these forges comprises a bracket as 141 connected with the positive pole of one of the secondary coils or with the positive ring 120 of the converter and a bracket as 142 connected with the negative pole of the same coil or with the negative ring 130. These brackets are composed of copper and the bracket 141 is provided with a clamp or work-holder 143 at its outer end and the bracket 142 is provided with a clamp or work-holder 144 at its outer end.

Several bent arms 180, 190, 195 and 200 are swiveled on a central pivot 210 and extend radially therefrom and depend downward in front of each secondary coil, there being one arm for each electric forge connected with the converter. Each of these arms is provided with a double-faced spring brush or circuit closer 220 adapted to slide between and electrically connect the ends of the incomplete rings or C-shaped plates of each secondary coil and throw more or less of said plates into or out of circuit, thus increasing or reducing the voltage according to the character of the current required by the work. These brushes consist of a body plate 221 attached to the lower end of the depending portion of the bent arm, a spring 222 attached to the front end of the said plate at its under side, and a spring plate 223 attached to the front end of said plate at its upper side. Any modification in the manner of connecting the secondaries for the purpose of increasing or reducing the voltage would come within the scope of this invention. The bent arms are provided with handles as 181 at their lower ends by means of which they are swung on the pivot. When the arms are moved to the ex-

treme left, the double-faced brushes slide into the gaps between the ends of the C-shaped plates and serve as conductors connecting the ends of said plates and bringing all of said plates into action as parts of the secondary coil. As the arm is swung toward the right the double-faced brush slides out of contact with the first plate to the left and cuts it out, rendering it inactive. By moving the arms still farther to the right the middle plate may be cut out and rendered inactive.

In the Burton, Eddy and Briggs Patent No. 475,232, hereinbefore cited, the secondary currents were regulated through a rheostat disposed in the exciter circuit. The converter herein shown may be connected with the electric source in the same manner and the same system may be used to first determine in a general way the amount of excitation of the field of the main generator required to give the proper working volume of current from the transformer according to the kind of work being done. When this is done, the rheostat of the exciter circuit is left in that position so that the regulation is maintained at an even point. Such further regulation as is required to properly heat the piece or pieces in the work holders of the transformer is obtained by varying the voltage in the secondaries thereof. The bent arms may be connected together rigidly, forming a swiveling frame as shown in Figs. 2 and 5, or each may be independent of the other, as shown in Fig. 4.

In the use of this transformer for metal heating purposes where bars of the same size are to be heated at all the different forges, the swiveling frame is adjusted so as to include one, two or more of the plates of each secondary coil according to the volume of the current desired. When bars of different sizes are to be heated in the different forges independent swiveled arms are employed similar to those represented in Fig. 4, so that while one turn or plate may be in circuit in respect to its secondary coil, two turns or plates may be in circuit in another coil and so on. The workman at each forge by grasping the handle as 181 and moving the arm can regulate the secondary current at will, so as to obtain a current suitable to heat the piece he is working. The bar as 300 to be heated closes the circuit between the metal holders of each forge and the passage of the current heats it in a few seconds to a forging temperature between said metal holders.

We claim as our invention—

1. An electric current converter provided with metal holders adapted to heat bars, rods, blanks or billets of metal of different dimensions at one or more points at the same time, and with means for varying the volumes of the secondary current independent of the primary current at the different points while the heating is taking place.

2. An electric converter provided with two or more pairs of metal holders adapted to heat

metal rods, blanks, bars or billets of varying dimensions at one or more places about the converter, and means for varying the quantity of the secondary current independent of the primary current at each pair of metal holders independently of each other pair.

3. An electric transformer having a secondary coil composed of a series of incomplete rings, and a movable brush for completing the circuit of any one or more of said rings.

4. A transformer having a secondary coil composed of a series of incomplete rings, a swiveling arm and a double faced brush on said arm for connecting the ends of the rings and closing the circuit between any one or more thereof.

5. A transformer having a number of secondary coils, each composed of a series of incomplete rings, and pivoted arms carrying brushes for completing the rings and closing the circuits of any one or more thereof in their respective coils.

6. A transformer having a number of secondary coils, each composed of a series of incomplete rings, pivoted arms movable inde-

pendently of each other, and a circuit closer for completing the rings and closing the circuits of any one or more thereof disposed on said arms.

7. An electric current transformer having a number of secondary coils, each composed of a series of incomplete rings or C-shaped plates, an exterior ring surrounding said coils and connected to the positive poles thereof, an exterior ring connected with the negative poles of said coils, and movable brushes for completing said plates and closing the circuits of any two or more thereof in the same coil.

8. An electric transformer having a secondary coil composed of a number of incomplete rings or C-shaped plates and bridges connecting the upper and lower edges of said plates, and means for completing said rings and closing the circuits of any two or more thereof.

GEO. D. BURTON.
EDWIN E. ANGELL.

Witnesses:

W. H. BOSS,
CHESTER MARR.