

(19)



(11)

EP 2 803 291 B1

(12)

EUROPEAN PATENT SPECIFICATION

(45) Date of publication and mention of the grant of the patent:
08.03.2017 Bulletin 2017/10

(51) Int Cl.:
A45D 29/00 (2006.01) A45D 34/04 (2006.01)

(21) Application number: **13736173.9**

(86) International application number:
PCT/JP2013/050572

(22) Date of filing: **15.01.2013**

(87) International publication number:
WO 2013/105669 (18.07.2013 Gazette 2013/29)

(54) **APPLICATOR IMPLEMENT**

APPLIKATORVORRICHTUNG

OUTIL APPLICATEUR

(84) Designated Contracting States:
AL AT BE BG CH CY CZ DE DK EE ES FI FR GB GR HR HU IE IS IT LI LT LU LV MC MK MT NL NO PL PT RO RS SE SI SK SM TR

(30) Priority: **13.01.2012 JP 2012004760**
11.01.2013 JP 2013003512

(43) Date of publication of application:
19.11.2014 Bulletin 2014/47

(73) Proprietor: **Mitsubishi Pencil Company, Limited**
Tokyo 140-8537 (JP)

(72) Inventor: **UEHARA, Junya**
Fujioka-shi
Gunma 375-8501 (JP)

(74) Representative: **Vossius & Partner**
Patentanwälte Rechtsanwälte mbB
Siebertstrasse 3
81675 München (DE)

(56) References cited:
FR-A1- 2 836 029 FR-A1- 2 948 266
JP-A- 2006 204 332 US-A- 2 399 463
US-A- 2 568 328

EP 2 803 291 B1

Note: Within nine months of the publication of the mention of the grant of the European patent in the European Patent Bulletin, any person may give notice to the European Patent Office of opposition to that patent, in accordance with the Implementing Regulations. Notice of opposition shall not be deemed to have been filed until the opposition fee has been paid. (Art. 99(1) European Patent Convention).

Description

Technical Field

[0001] The present invention relates to an applicator implement that is used in association with making up of fingertips of the hands, in particular, in the nail art field for French nails (painting of the application liquid on the nail front ends) for applying the manicure liquid around nail tips, aiming at easy and exact application of the liquid mainly around the nail tips (from one side through the front end to the other side) of the hands in a short time, and that enables application of drawing lines of a fixed width along the shape of the front end of the nail without regard to the dominant hand and experience.

Background Art

[0002] Examples of the applicator implements for taking out the application liquid from a container by using an applicator body to apply the liquid on a target site, include manicure products for applying a manicure liquid.

[0003] In manicuring, the French nail manicure for painting the manicure liquid around the tips of the nails in association with making up of fingertips of the hands, has been known.

[0004] This French nail manicure is a typical example when nails are painted by oneself. Right before French nail painting, a base liquid is applied over the whole surface of the nails. Then after French nail painting, an additional coat liquid for protection is applied. Since the French manicure thus needs many steps, there have been demands for a method of painting that enables quick and fine finishes as easy as possible.

[0005] Conventionally, generally known application methods of French nails can be classified into following four types.

1. Painting with brushes and pen cores

[0006] This is the most typical application method of French nails, and application is performed by painting along the tips of the nails with an applying part (brush or pen core) similar to that for the base liquid. In this process, a special sheet for shaping French nails and/or a fixing jig for fixing the fingers for easy application may be used (see, for example Japanese Patent Application Laid-open 2004-59035).

2. Painting with a special pattern-shaped brush

[0007] This special brush has a brush shape similar to the round shape of the nail with its front part U-shaped similar to the front curved surface of the nail. It is possible to perform French nail manicure by painting the nails directly with the shape of the special brush (see, for example Japanese Patent Application Laid-open 2004-8826).

3. Painting by abutting a shaped pen core on the nail

[0008] An approximately key-shaped applying part (fabric pen core) is pressed and fixed against the tip edge of the nail and moved left and right using the edge as a guide, whereby French nail manicuring can be performed without regard to the dominant hand (see, for example Japanese Patent Application Laid-open 2006-204332).

4. Applying a pattern-shaped stickers

[0009] Instead of using a liquid, it is possible to produce French nails by nipping a thin sticker with a pair of tweezers or the like to apply the sticker to the nail tip (see, for example Japanese Patent Application Laid-open 2006-296620).

[0010] US 2,568,328 discloses an applicator device including a combined guard and holder member which is of generally inverted channel shape throughout the greater portion of its length. The member has opposite side walls, joined at their upper ends by a top wall. At one of its ends, the holder member is provided with an end wall from which projects a stem. The stem may be receivable in an axial hole of a handle or may be further extended to provide the handle itself. A screw type bottle cap, carried at the outer end of the handle adapts the device to be normally disposed in a bottle containing a supply of the liquid nail polish.

Summary of the Invention

Problems to be Solved by the Invention

[0011] However, the applicator implement disclosed in Japanese Patent Application Laid-open 2004-59035 is designed to paint the nail tips with a brush or pen core in a usual freehand drawing manner. Because of the freehand drawing, the finish depends on the individual user's skills and experience, so that it is difficult for a beginner to stably position the applicator and perform fine painting. Even if skills and experience are enhanced, there occur many cases where the finish cannot bring satisfaction.

[0012] Similarly to the above case, the applicator implement disclosed in Japanese Patent Application Laid-open 2004-8826 is difficult to position to the applied place, needing time for practice. The same can be said for application to the dominant hand. Since the brush is fixed in a rounded shape, this configuration is not suited to flat nail tips. Further, since the brush is U-shaped in plan view, the application liquid flows downward so that the application liquid in the middle part of the nail is prone to be thin.

[0013] Though the applicator implement disclosed in Japanese Patent Application Laid-open 2006-204332 enables stable painting on the nails of the left and right hands without regarding to whether or not the hand is the dominant one, there frequently occurs the problem that the applicator body, which should be fixed to a po-

sition by being pressed against the nail tip, is displaced out of the position if the pressing force is strong. Particularly, at the side of the nail, the applying part is liable to partially come off the position to be fixed when it comes to the side of the nail, soiling the nail. Further, since the pen core is pressed against the nail tip every time it is used, the maintenance (endurance) of the pen core's shape is the problem to be solved.

[0014] Since the applicator implement disclosed in Japanese Patent Application Laid-open 2006-296620 needs to set a sticker by peeling off the sticker from the base by the pair of tweezers or the like, the sticker is prone to displace in the longitudinal and transversal directions with respect to the nail tip, producing poor appearances. Accordingly, time is needed for practice. Further, once the adhesive surface is polluted, the adhesion is degraded, producing the problem that the sticker is likely to drop. Moreover, a step corresponding to the thickness of the sticker is necessarily formed from the nail to the sticker surface, causing a sense of discomfort. Still more, since the sticker is markedly brittle, it is vulnerable, resulting in poor endurance. Further, stickers are inherently expensive.

[0015] The present invention has been devised in view of solving the above problems, it is therefore an object of the present invention to provide an applicator implement, which enables the user to perform easy, fast and stable drawing without regarding the user's experience and skills, and to draw a line parallel to the front edge of the nail and paint easily and exactly in a short time without the curved surface of the nail, in other words, which enables the individual to do a French nail manicure with a feeling of satisfaction of the finish. It is also an object to provide a low-cost applicator implement that will not stain nails.

Means for Solving the Problems

[0016] The present invention is an applicator implement according to claim 1.

[0017] In the present invention, it is possible to perform stable application in a simple manner. Formation of the applying surface of the applying part in, for example, a U-shaped inner surface configuration, enables a nail to insert therein and be painted with a drawing line by moving the applying part in a direction the user wants to paint the nail.

[0018] In the present invention, it is preferable that the applicator body for painting the target object is formed by a fabric body by shaped by using fibers and resin.

[0019] In the present invention, it is preferable that the applicator implement is one for French nails, in which a front end part of the applicator body is formed with a flat applying surface extending in an axial direction of the applicator body so that a tip of a nail can be placed through the slit and applied with the application liquid in a predetermined width by means of the applying surface.

[0020] Accordingly, the fabric body forming the appli-

cator body is configured in a U-shape so as to limit the insert of the nail, hence the nail can be positioned when the nail tip is inserted up to the insert limit. As result, the nail is fixed relative to the applying part while the nail tip which is to become the applied surface abuts the applying part of the applicator body, hence is applied with the liquid, whereby it is possible to paint a stable drawing line by just moving the applying part or the nail in the direction the user wants to paint.

[0021] Further, changing the depth of the U-shaped depression in the front end of the applicator body makes it possible to change the width of painting in nail tips.

[0022] Changing the width of the U-shape in the front end of the applicator body assures suitable width without regard to the thickness of nail tip.

[0023] Moreover, the top and bottom surfaces of the U-shape in the front end of the applicator body assume straight lines (the surfaces themselves are flat surfaces) when viewed from the front side of the applying surface, or curved lines of R10 or greater (the cross sections are flat surfaces), so that it is possible to smoothly paint nails if individual fingers have different curvatures.

[0024] In the present invention, it is preferable that the applicator implement is one for French nails, in which the front end part of the applicator body is formed with a flat applying surface extending in the axial direction of the applicator body so that the tip of a nail can be placed through the slit of the applicator cover and applied with the application liquid in a predetermined width by means of the applying surface.

[0025] In this way, the applicator cover is formed with a hole to which the applicator body is inserted from the rear so as to cover the applicator body while a slit is provided on the front end. Thus, by providing the cover that enables the applicator body to be partly exposed through the slit when the applicator body is inserted into the cover, it is possible to expose the applying surface of the applicator body from the top surface of the slit in the applicator cover and paint the surface to be applied with the top surface. Further, a wide enough clearance that allows insertion of the nail is formed between the exposed surface and the bottom surface of the applicator cover.

[0026] The slit configuration in the applicator cover is formed of a flat surface or a curved line of R10 or greater when view from front side of the slit, so that it is possible to smoothly paint nails even if individual fingers have different curvatures.

[0027] As the depth of the slit in the applicator cover is changed, so the insert limit of nails is also changed. Accordingly, it is possible to change the width of the painted line on the nail which is to become applied portion.

[0028] In the present invention, the approximately central part of the applicator body in its axial direction is reduced in diameter compared to the outside diameter of the front and rear portions and the reduced diametric part is accommodated inside the barrel cylinder in a states that the applicator body is covered by the applicator cover and is assembled.

[0029] This structure enables temporal retention of the application liquid in the reduced diametric portion and hence can prevent liquid flooding even if an excess amount of the liquid exceeding the saturated absorption of the applicator body made of fabric body and the like is delivered to the applicator body.

[0030] In the present invention, it is preferable that in addition to the slit, another hole for exposing an external surface of the applicator body is provided for the applicator cover so that the exposed external surface of the applicator body can be used for application when the applicator cover is fitted on the applicator body.

[0031] This hole that exposes the external surface of the applicator body enables painting of the target object, so that this arrangement is highly convenient.

[0032] In the present invention, it is preferred that the applicator cover has a rear opening through which the applicator body can be inserted, and two slits different in depth, formed on a front end, the front end of the applying part of the applicator body is cut out, forming two applying surfaces opposing inwardly each other, the applying surfaces appear from respective slits of the applicator cover when the applicator body is inserted in the applicator cover, wide enough gaps that allow a nail to be inserted through the slit between the applying surfaces are formed, whereby only one side of a nail tip can be painted by the appeared applying surface, and, by selecting one of the two slits, lines having different widths from each other for French nails allows to be drawn.

[0033] In the present invention, it is preferable that the applicator cover has a rear opening through which the applicator body can be inserted, and two slits different in depth, formed on a front end, outsides of the front end of the applying part of the applicator body are formed with two applying surfaces having a distance between each other, the applying surfaces appear from respective slits of the applicator cover when the applicator body is inserted in the applicator cover, wide enough gaps that allow a nail to be inserted between a U-shape and an exposed fabric body are created, whereby only one side of a nail tip can be painted by the appeared applying surface, and, by selecting one of the two slits, lines having different widths from each other for French nails allows to be drawn.

[0034] As described above, since two slits are formed in the front end of the applicator cover so as to have different slit depths, the applicator body is exposed from one side surface of the surfaces in the slit, with respect to the width direction, of the applicator cover, hence a wide enough gap that allow a nail to be inserted between the fabric body which is to become applicator body and the lower surface of the slit is created. Accordingly, one surface of the nail tip alone can be painted by the exposed surface. Since the two slits are different in depth (insert limit), it is possible to draw lines of different line widths.

[0035] It is preferable in the present invention that the applicator body is covered by a front barrel located in front and the applicator cover in front of the front barrel,

the applicator cover is removable from the front barrel, and the applicator body is also removable.

[0036] It is preferable in the present invention that the applicator body is covered by a front barrel located in front and the applicator cover in front of the front barrel, and the applicator cover and the front barrel are formed integrally. This configuration makes it possible to decrease the number of parts and reduce the cost.

[0037] In the present invention, the material of applicator cover 56 is preferably high-polymer plastics such as PP (polypropylene), PE (polyethylene), PBT (polybutylene terephthalate), POM (polyoxymethylene), and PA (polyamide) or metals, and the material is further preferable if it presents chemical resistance against the organic solvent liquids that are used for French nails.

[0038] The present invention is an applicator implement that enables application of an application liquid to a target object by bringing an applying part of an applicator body impregnated with the application liquid into contact with the target object, comprising: an applicator body formed with a slit on a surface of an applying part, wherein a front end part of the applicator body is formed with an applying surface extending in an axial direction of the applicator body so that a tip of a nail can be placed through the slit and applied with a application liquid in a predetermined width by means of the applying surface.

Advantages of the Invention

[0039] According to the applicator implement of the present invention, the application liquid in, for example, a container is fed to the applying part by twist-up, clicking or any other operation so as to allow the applying part to paint a target object. The front end of the applying part is shaped with a U-shape, so that the applying surface of the applying part is positioned in the slit in a state that the applying part is covered with the applicator cover. When a target object such as a nail or the like is inserted into the slit and the applying body is moved left and right as sliding along the nail shape, the applying surface can easily apply a line of the application liquid of uniform width to a predetermined part of the target object, for example, the tip of the nail.

[0040] The thus achieved simple operation makes it possible to improve the conventional dissatisfactions or time consumption (for the time for practice, painting skills for non-dominant hand, unstable painting of drawing lines, soiling of nails due to failures and the like) remarkably. In particular, since this invention is featured by the quick and beautiful finish, the user can enjoy nail art all the more.

[0041] Further, since insertion of the applicator body into the slit-equipped applicator cover for covering the applicator body of a fabric body and the like enables exposure of the applicator body from the slit of the applicator cover, it is possible to paint one surface of the nail by inserting the nail up to the insert limit of the slit of the applicator cover and fixing thereat.

[0042] Also, by changing the depth of the slit, it is possible to change the width of application on the nail.

[0043] Further, provision of two slits having different depths in the applicator cover produces an excellent advantage for the user to make choice from two application widths.

[0044] In the present invention, the applicator implement is constructed such that includes an applicator body formed with a slit on the surface of an applying part, and is constructed such that the front end part of the applicator body is formed with an applying surface extending in the axial direction of the applicator body so that the tip of a nail can be placed through the slit and applied with the application liquid in a predetermined width by means of the applying surface. As a result, without use of an applicator cover, it is possible to bring the nail tip into contact with the applying surface through the slit on the surface of the applicator body, thereby apply the application liquid in a predetermined width on the nail tip. Omission of the applicator cover makes the structure simpler.

Brief Description of Drawings

[0045]

[FIG. 1] is a half section illustrating the overall configuration of an applicator implement for French nails according to the embodiment of the present invention.

[FIG. 2] is a component drawing of an applicator body (fabric body) of example 1, (a) a front view, (b) a perspective view (c) a side view and (d) a vertical section.

[FIG. 3] is a component drawing of an unassembled applicator cover of example 2, (a) a front view, (b) a perspective view (c) a top view, (d) a side view, (e) a vertical section and (f) a rear view.

[FIG. 4] is a component drawing of an applicator body (fabric body) of example 2, (a) a perspective view from a front upper position, (b) a front view, (c) a perspective view from a front lower position, (d) a top view, (e) a side view and (f) a vertical section.

[FIG. 5] is a partial assembly diagram of the applicator body (fabric body) of example 2 being inserted into an applicator cover, (a) a perspective view from a front lower position, (b) a front view, (c) a perspective view from a front upper position, (d) a top view, (e) a side view and (f) a vertical section.

[FIG. 6] is a component drawing of a variation (variational example 1) of an unassembled cover of example 2 with its slit width enlarged, (a) a perspective view from a front upper position, (b) a front view, (c) a perspective view from a front lower position, (d) a top view, (e) a side view, (f) a vertical section and (g) a rear view.

[FIG. 7] is a partial assembly diagram of the applicator body (fabric body) being inserted into a cover, in the variation (variational example 1) of the un-

assembled cover of example 2 with its slit width enlarged, (a) a perspective view from a front upper position, (b) a front view, (c) a perspective view from a front lower position, (d) a top view, (e) a side view and (f) a vertical section.

[FIG. 8] is a component drawing of an unassembled cover of example 3, (a) a perspective view from a front upper position, (b) a front view, (c) a perspective view from a front lower position, (d) a top view, (e) a side view, (f) a vertical section and (g) a rear view.

[FIG. 9] is a partial assembly diagram of the applicator body (fabric body) of example 3 being inserted into a cover, (a) a perspective view from a front upper position, (b) a front view, (c) a perspective view from a front lower position, (d) a top view, (e) a side view and (f) a vertical section.

[FIG. 10] is a component drawing of an applicator cover of example 4, (a) a perspective view from a front upper position, (b) a front view, (c) a perspective view from a front lower position, (d) a top view, (e) a side view, (f) a vertical section and (g) a rear view.

[FIG. 11] is a partial assembly diagram of the applicator body (fabric body) of example 4 being inserted into an applicator cover, (a) a perspective view from a front upper position, (b) a front view, (c) a perspective view from a front lower position, (d) a top view, (e) a side view and (f) a vertical section.

[FIG. 12] is a component drawing of an applicator body (fabric body) of example 5, (a) a perspective view from a front upper position, (b) a front view, (c) a top view, (d) a side view and (e) a vertical section.

[FIG. 13] is a partial assembly diagram of the applicator body (fabric body) of example 5 being inserted in an applicator cover, (a) a perspective view from a front upper position, (b) a front view, (c) a perspective view from a front lower position, (d) a top view, (e) a side view and (f) a vertical section.

[FIG. 14] is a component drawing of an applicator cover (variational example 2), which is the applicator cover of example 2 integrated with a part of a front barrel, (a) a front view, (b) a perspective view from a front upper position, (c) a side view and (d) a vertical section.

[FIG. 15] is a partial assembly diagram of the applicator body (fabric body) of FIG. 4 being inserted in the applicator cover of FIG. 14, in the variational example 2, (a) a front view, (b) a perspective view from a front upper position, (c) a side view and (d) a vertical section.

[FIG. 16] is a partial assembly diagram of an applicator body (fabric body) of example 6 be inserted in an applicator cover and attached to a front barrel, (a) a perspective view from a front upper position, (b) a front view, (c) a perspective view from a front lower position, (d) a top view, (e) a vertical section of the state (d), (f) a side view, (g) a vertical section of the state (f), (h) a bottom view and (i) a rear view.

[FIG. 17] is a partial assembly diagram of an appli-

cator body (fabric body) of example 6 being inserted in an applicator cover, (a) a perspective view from a front upper position, (b) a front view, (c) a perspective view from a front lower position, (d) a top view, (e) a vertical section of the state (d), (f) a side view, (g) a vertical section of the state (f), (h) a bottom view and (i) a rear view.

[FIG. 18] is a component drawing of an applicator cover of example 6, (a) a front view, (b) a perspective view from a front upper position, (c) a top view, (d) a vertical section of the state (c), (e) a side view, (f) a vertical section of the state (e), (g) a bottom view, (h) a rear view and (i) a perspective view from a front lower position.

Mode for Carrying Out the Invention

[0046] Next, the embodiment of the present invention will be described with reference to the accompanying drawings.

[0047] FIG. 1 is a half section showing an applicator implement according to the embodiment of the invention. FIGS. 2 to 18 illustrate examples of individual parts, not all according to the present invention.

[0048] Parts allotted with the same reference numerals show identical components.

[0049] As shown in FIG. 1, the applicator implement according to the embodiment is able to apply an application liquid by bringing an applying part 52 of an applicator body 50 impregnated with the application liquid into contact with a target object. The applicator implement includes applicator body 50 having a flat applying surface 58 (see FIG. 2) in applying part 52, and an applicator cover 56 that is fitted on the applicator body 50 to cover the applying part 52 and formed with a slit 54 for creating communication between the outside and the inside. When the applying part 52 is covered by the applicator cover 56, applying surface 58 of the applying part 52 is positioned inside the slit 54. By inserting a target object into and through the slit, the applicator implement can apply the application liquid on the desired part of the target object by applying surface 58.

[Overall Configuration of Applicator Implement]

[0050] The whole of the applicator implement of the embodiment will be described.

[0051] As shown in FIG. 1, the applicator implement is constructed such that an approximately cylindrical outer barrel 10 with an open rear end 10b has a tank-like inner barrel 12 arranged movably forward and backward within outer barrel 10, inner barrel 12 moves forward relative to outer barrel 10 as the user clicks a rear end part 12b of inner barrel 12 so as to operate an aftermentioned valve mechanism 14 arranged inside front end part 12a of inner barrel 12, thereby supply the application liquid to applicator body 50 arranged at a front end part 10a of outer barrel 10. The part projected forward from front barrel 22

in applicator body 50 is covered with an aftermentioned applicator cover 56.

[0052] Front end part 10a of outer barrel 10 is made small stepwise in diameter. Abutted on the front face of the front end part 10a is the outer periphery (spreading flange-like) of bowl-shaped front end part 18a of an ink feed pipe (a pipe passage for flowing the application liquid from valve mechanism 14 to the applicator body 50 side) 18. The rear part of applicator body 50 is inserted into front end part 18a of the ink feed pipe 18 with a seal ring 20 therebetween. Hollow-tubular tapering front barrel 22 is fitted on the outer barrel front end part 10a, enclosing by the hollow of front barrel 22, the applicator body 50 from its middle part to the rear, seal ring 20 and the front end part 18a of ink feed pipe 18, so as to fix applicator body 50, seal ring 20 and the front end part of ink feed pipe 18 to outer barrel 10. A cap 24 that encloses and protects applicator body 50 is removably fitted on outer barrel front end part 10a. Cap 24 has an inner cap 24 therein, which is urged by a spring 24b so as to press front barrel 22.

[0053] The inner barrel 12 is closed at rear end 12b to form a liquid reserving space 12c for reserving the application liquid therein (in which an agitator ball 12d may be held). On the other hand, the valve mechanism 14 is mounted in front end part (the front end part of the inner barrel) 12a and fixed inside by inner front barrel 26. Detailedly, in a state where valve mechanism 14 is mounted inside the front small-diameter part of inner barrel 12, or front end part 12a, rear end part 18b of ink feed pipe 18 is slidably connected to valve mechanism 14 while inner front barrel 26 is fixed to front end part 12a of the inner barrel by screw-fitting or any other means with a packing 28 inserted between itself and the front end part of valve mechanism 14.

[0054] Herein, the valve mechanism 14 allows and stops supply of the application liquid toward applicator body 50 when a valve seat 30 and valve rod 38 relatively move in the axial direction, on the communication path between the liquid reserving space 12c for reserving the application liquid and applicator body 50.

[0055] Valve seat body 30 of valve mechanism 14 is an approximate cylinder that is open at both ends in the axial direction and has liquid-tight portions that are formed therein on the front side (front side valve member 32) and on the rear side (rear side valve member 34) and come in sliding contact with valve rod 38. The rear side opening faces liquid reserving space 12c while the front side opening faces the applicator body 50 side.

[0056] Projected radially inward from the interior wall of rear side valve member 34 of valve seat body 30 is a rib that extends from the approximate longitudinal center of the wall to the rear side to guide valve rod 38. The valve rod 38 is accommodated in the hollow of front side valve member 32 and rear side valve member 34 of valve seat body 30 so as to be movable forward and rearward. A spring member 36 that is fit on the valve rod 38 is disposed inside the same hollow so as to urge the valve

rod 38 forward.

[0057] Specifically, front valve member 32 overall has an approximately cylindrical shape with a large-diametric flange at the front end and the rear side interior peripheral surface greater in diameter than the front interior peripheral surface. This rear side interior peripheral surface forms the front side liquid-tight portion. On the other hand, rear side valve member 34 has a hollowed, approximately cylindrical shape with large-diametric flange at the front end and the rear end reduced stepwise in diameter. The interior peripheral surface of this reduced-diametric portion forms the rear side liquid-tight portion. The front side valve member 32 is concentrically inserted overlappedly into rear side valve member 34 from the front side until the aforementioned flanges abut each other. Further, in a state that packing 28 is placed in front of the flanges, inner front barrel 26 is screwed and fixed to cover front end part 12a of the inner barrel. Here, the front face of the reduced-diametric portion at the rear side end of rear side valve member 34 serves as a seat for the spring member 36.

[0058] Formed on the outer periphery of valve rod 38 are a front side piston part 38a that liquid-tightly slides on the front side liquid-tight portion of front side valve member 32 in the valve seat body 30, and a rear side piston part 38b that liquid-tightly slides on the rear side liquid-tight portion of rear side valve member 34 in the valve seat body 30 while a space 40 that allows communication of the application liquid is formed between the outer periphery in the approximately center of the valve rod 38 and the interior surface of the valve seat body 30.

[0059] Specifically, front side piston part 38a of valve rod 38 is formed with a flexible large-diametric umbrella-like flange. Rear side piston part 38b is formed with a smooth outer peripheral surface tapering rearwards. When valve rod 38 moves rearwards, the small-diametric rear end part passes through the opening of the rear side valve member 34, then the large-diametric middle part closely contacts to and slides on the liquid-tight portion on the rear side of rear side valve member 34.

[0060] An annular projection 42 is formed on the inner wall of outer barrel 10. When inner barrel 12 moves rearwards by a certain distance or greater, inner front barrel 26 abuts this annular projection 42 so as to prevent inner barrel 12 from moving to the rear further and coming off.

[0061] Further, rear end part 18b of ink feed pipe 18 communicating with applicator body 50 is inserted into the front side opening of valve seat body 30. Inserted into this ink feed pipe 18 is an induction rod 44 for inducing the application liquid toward applicator body 50.

[0062] As to materials for individual parts of the applicator implement, applicator body 50 may use a fabric body of acryl, nylon, polyester, polyacetal (POM) or the like.

[0063] The inner barrel and output barrel 10 may use polypropylene (PP), polybutylene naphthalate (PBT), nylon (PA) and polyacrylonitrile (PAN); front barrel 22, cap 24, inner cap 24a and inner front barrel 26 may use poly-

butyl-terephthalate (PBT), polypropylene (PP), nylon (PA) and polyacrylonitrile (PAN); packing 28 may use EPDM, silicone, NBR (nitrile rubber), IIR (polyisobutylene rubber) and fluorine; the seal ring may use low-density polyethylene (LDPE, LLDPE), high-density polyethylene (HDPE), polypropylene (PP); front side valve member 32, rear side valve member 34 and valve rod 38 of valve seat body 30 may use high-density polyethylene (HDPE), low-density polyethylene (LDPE, LLDPE), polypropylene (PP); and, spring 24b of cap 24 and spring member 36 may use stainless steel (SUS).

[0064] Induction rod 44 is preferably formed of a material presenting good wettability to the application liquid, for examples including, metals such as stainless steel (SUS), resin such as polyacetal (POM), fiber bundle core or sintered compact of polyester, acryl or the like, or synthesized resin molding core having liquid flow channels in the axial direction such as polyacetal (POM).

[0065] Next, examples of applicator body 50 and applicator cover 56 of the applicator implement will be described.

[0066] The applicator implement is preferably used for French nails, or applying the application liquid to nails tips. The application liquid for French nails should have a viscosity that enables applicator body 50 made of fibers to absorb/apply and apply the liquid on nails. It is preferably that the viscosity falls within a range from 50 mpa·s to 200 mpa·s.

[0067] The material of applicator cover 56 may be high-polymer plastics such as polypropylene (PP), polyethylene (PE), polybutyl-terephthalate (PBT), polyacetal (POM), and nylon (PA), or metals, and preferably presents chemical resistance against the organic solvent liquids used for French nails.

[Applicator Body according to Example 1]

[0068] Next, example 1 of the applicator body arranged in the above applicator implement will be described.

[0069] FIG. 2 shows applicator body 50 according to example 1.

[0070] The applicator implement used in example 1 has the same outside diameter with that of applicator body 50 of the applicator implement of FIG. 1.

[0071] As shown in FIG. 2, applicator body 50 roughly has a bar-shaped configuration with its applying part 52 at the front end cut out in a U-shape when viewed from side. Thus, opposing applying surfaces 58 are formed in the U-shaped arrangement. Specifically, the U-shaped arrangement was formed of 1.5 mm deep and 1.5 mm wide. Accordingly, the insert limit of the nail is 1.5 mm, and it is possible to paint nails having the maximum thickness of 1.5 mm.

[0072] This fabric body was assembled in the applicator implement of FIG. 1, and application performance was evaluated.

[0073] To begin with, the nail was put into the fabric body up to the insert limit, and the nail was fixed at the

point of the insert limit of the fabric body. In this condition, the nail was painted by sliding the fabric body along the top edge of the nail. As a result, it was possible to draw a line of 1.5 mm wide easily and beautifully.

[0074] Example 2 relates to an applicator cover.

[0075] FIG. 3 is a component drawing of an applicator cover. FIG. 4 is a component drawing of applicator body 50. FIG. 5 is an assembly diagram of applicator cover 56 and applicator body 50.

[0076] In example 2, as shown in FIG. 3, applicator cover 56 forms a cap-like configuration in which the front end is spherically shape while the rear part become slightly spread like a skirt. Applicator cover 56 is formed in its front end with a window-forming slit 54 that is rectangularly cut out. One endface of slit 54 is continuously extended like a tread forming a step 54a inside applicator cover 56. The other endface of slit 54 is extended spherically both on the inner and outer surfaces.

[0077] Specifically, the slit 54 is 1.5 mm wide with the nail insert limit set at 1.8 mm. The outside diameter of applicator cover 56 is 5.3 mm. The cover has a key-like inner hollow similar to the shape of the applicator body and establishes communication.

[0078] On the other hand, applicator body 50 of example 2 is formed such that, as shown in FIG. 4, the one side of the front end part of applying part 52 is cut out like a notch to form a flat applying surface 58 extending in the axial direction of the applicator body 50. Applicator body 50 has an outside diameter of 4.5mm with its front end spherically shaped which is to become applying part 52, and is ground in flat along the axial direction, forming applying surface 58.

[0079] Further, in order for temporal collection of the liquid, the middle part is annularly cut out to be reduced to 4 mm in diameter, forming a depressed portion 60.

[0080] The fabric body having a porosity of 50% or more was used as applicator body 50.

[0081] In the example 2, as applicator body 50 is fitted into applicator cover 56, applying surface 58 is exposed 0.5 mm relative to slit 54 as shown in FIG. 5. Accordingly, it is possible to insert a nail without difficulty if the nail is as thick as about 1 mm. Applicator body 50 is positioned by the spherical part of applicator cover 56 or by step 54a of applicator cover 56. With the thus constructed applying part 52, the nail was inserted into slit 54 and fixed at the insert limit while the applicator implement was moved right and left along the top edge of the nail, whereby it was possible to draw a painting line of uniform width easily and beautifully.

[Variational Example 1 of Example 2]

[0082] Variational example 1 of example 2 gives a configuration in which applicator cover 56 shown in FIG. 6 is formed with a slit 54 that is wider (deeper in side view) than that shown in FIG. 3. Replacement of the applicator cover 56 shown in FIG. 3 with this configuration provides the assembly shown in FIG. 7 so that it is possible to

change the application width of slit 54.

[Assembly of applicator cover 56 of example 3 with applicator body 50]

[0083] FIG. 8 is an illustrative diagram of applicator cover 56 of example 3. FIG. 9 is an assembly diagram of applicator cover 56 and applicator body 50 of example 3. The applicator body 50 of example 3 is the same as that of example 2 shown in FIG. 4.

[0084] This example 3 is a further improved version of the assembly of example 2. Another hole 56a is formed in the top of applicator cover 56, separately from slit 54, so that the outer peripheral surface of applying part 52 is exposed from the hole 56a.

[0085] In this example 3, similarly to example 2, it was possible to easily paint a drawing line of uniform width simply and beautifully. In addition, it was possible to perform a correction of applying and point making by use of applying part 52 exposed through the top hole.

[Assembly of Example 4]

[0086] FIG. 10 is a component drawing of applicator cover 56 according to example 4, and FIG. 11 is an illustrative diagram of the assembly.

[0087] In example 4, the applicator body 50 shown in FIG. 2 is used, and the applicator cover 56 shown in FIG. 11 and the applicator body 50 are assembled. In example 4, as shown in FIG. 10, two slits 54a and 54b different in depth (and width) are formed in applicator cover 56, and applicator body 50 is inserted into this applicator cover 56. In applicator body 50 shown in FIG. 2, applying surfaces 58, 58 opposing each other are made to face (exposed) through slits 54a and 54b, respectively.

[0088] In application work, the same result as in the example 2 could be obtained. Further, since slits 54a and 54b were different, two kinds of drawing lines of different line widths could be formed.

[Assembly of Example 5]

[0089] FIG. 12 is a component drawing of an applicator body of example 5, and FIG. 13 is an illustrative diagram of the assembly of example 5.

[0090] In example 5, the applicator cover 56 of example 4 shown in FIG. 10 is assembled with applicator body of FIG. 12, forming the assembly shown in FIG. 13.

[0091] As shown in FIG. 12, applicator body 50 is different from example 4, in that applying part 52 as the front end of applicator body 50 is cut out from both side across the axis to form an inverted T shape and applying surfaces 58, 58 are formed on both the sides of inverted T-shaped applying part 52. In the state where applicator 50 is assembled in applicator cover 56, applying surfaces 58 and 58 are exposed through slits 54a and 54b, respectively.

[0092] In this case, similarly to example 4, two kinds

of drawing lines of different line widths could be formed.

[Variational Example 2 of Example 2]

[0093] FIG. 14 shows applicator cover 56 of variational example 2 of example 2, and FIG. 15 shows applicator cover 56 with applicator body 50 inserted therein.

[0094] This variational example 2 gives a configuration in which, as shown in FIG. 14, the skirt-like portion that is formed continuously or integrally from the rear part of applicator cover 56 is further extended so that applicator cover 56 is integrated with front barrel 22. As applicator body 50, the one shown in FIG. 4 having applying part 52 cut out like a notch on one side forming applying surface 58 is used. Here, in FIGS. 14 and 15, the part of applicator cover 56 corresponding to the front barrel is shown by reference numeral 22A.

[0095] This variational example 2, when used for the applicator implement shown in the embodiment of FIG. 1, has the advantage of reducing the number of parts for front barrel 22 compared to the above examples 1 to 5.

[0096] [Assembly of Applicator Cover 56 of Example 6 in Applicator Body 50]

[0097] Example 6 will be described.

[0098] FIG. 16 is a partial assembly diagram of an applicator body (fabric body) according to example 6 inserted in applicator cover 56 and attached to front barrel 22. FIG. 17 is a partial assembly diagram of the applicator body (fabric body) inserted in the applicator cover before being attached to the front barrel 22. FIG. 18 is a component drawing of the applicator cover.

[0099] Example 6 is a further improved version of example 3 described with FIGS. 8 and 9 above, in that the rear part of applicator cover 56 is extended tube-like (shown by a tubular portion 56b) compared to the configuration of example 3.

[0100] As shown in FIG. 16, applicator cover 56 is assembled so that applicator body 50 and tubular portion 56b in the rear part of applicator cover 56 are inserted into front barrel 22. In assembling, the umbrella-like spreading portion in the front part of applicator cover 56 abuts the front end of front barrel 22 while tubular portion 56b is plunged into front barrel 22. Applicator body 50 is pressed by front barrel 22 through tubular portion 56b of applicator cover 56.

[0101] In the assembled condition, as shown in FIGS. 16 and 17, applying part 52 in the conical side surface of applicator body 50 is exposed through the top hole 56a while flat applying surface 58 is exposed from slit 54.

[0102] According to example 6, as shown in FIG. 16, since elastic resin applicator cover 56 (tubular portion 56b in the rear part thereof formed in a tube-like form) is interposed between applicator body 50 and front barrel 22, it is possible to produce a feeling of unity of front barrel 22 and applicator cover 56 as well as effectively preventing applicator cover 56 from coming off from front barrel 22.

[0103] According to the applicator implements includ-

ing applicator body 50 and applicator cover 56 of the above examples 1 to 6, variational examples 1 and 2, in the applicator implement using applicator body 50 that can absorb and apply a liquid to paint the tips of nails by dispensing a content liquid in liquid reserving space 12c of inner barrel 12 to applicator body 50 by means of valve mechanism 14 that supplies the content liquid as rear end part 12b of inner barrel 12 is clicked, when the portion for painting nail tips is formed in a U-shape, a nail inserted into slit 54 up to the insert limit of the U-shape can be positioned and fixed, whereby it is possible to provide an applying part for nail art that enables easy application of the liquid dispensed from the container to applicator body 50, to the nail, by moving applying part 52 left and right along the top edge of the nail.

[0104] Here, the applicator body 50 maybe formed with a curved surface. It is also possible to omit applicator cover 56 if application can be done with applicator body 50 alone. Omission of applicator cover 56 enables easy application with a simple configuration.

Industrial Usability

[0105] The applicator implement of the present invention is not only suitable for French nails, or painting around nail tips in association with making up of fingertips of the hands, but can also be used when lines of uniform width need to be drawn on a tip of a small object like nail tips.

Description of Reference Numerals

[0106]

10	outer barrel
10a	front end part of outer barrel
10b	rear end part of outer barrel
12	inner barrel
12a	front end part of inner barrel
12b	rear end part of inner barrel
14	valve mechanism
22	front barrel
30	valve seat body
44	induction rod
50	applicator body
52	applying part
54	slit
54a	slit step
56	applicator cover
56a	hole in applicator cover
58	applying surface
60	depressed portion

Claims

1. An applicator implement that enables application of an application liquid to a target object by bringing an

applying part (52) of an applicator body (50) impregnated with the application liquid into contact with the target object, comprising:

an applicator body (50) formed with a flat applying surface (58) in an applying part (52); and, an applicator cover (56) that is attached to the applicator body (50) to cover the applying part (52), formed with a slit (54) that creates communication from an outside to an inside,

wherein

under a condition in which the applicator cover (56) covers the applying part (52), the applying surface (58) of the applying part (52) is positioned inside the slit (54) so that the applying surface (58) can apply an application liquid to a predetermined portion of a target object by inserting a target object through the slit (54),

characterized in that

a depressed step (60) is formed in the approximate center of the applicator body (50) in the axial direction so that the step is housed inside a barrel cylinder when the applicator cover (56) is assembled to cover the applicator body (50).

2. The applicator implement according to Claim 1, wherein the applicator body (50) is formed by a fabric body shaped by using fibers and resin.
3. The applicator implement according to Claim 1 or 2, which is an applicator implement for French nails wherein a front end part of the applicator body (50) is formed with the applying surface (58) extending in an axial direction of the applicator body (50) so that a tip of a nail can be placed through the slit (54) and applied with the application liquid in a predetermined width by means of the applying surface (58).
4. The applicator implement according to any one of Claims 2 to 3, wherein in addition to the slit (54), another hole for exposing an external surface of the applicator body (50) is provided for the applicator cover (56) so that the exposed external surface of the applicator body (50) can be used for painting the target when the applicator cover (56) is fitted on the applicator body (50).
5. The applicator implement according to any one of Claims 1 to 4, wherein the applicator cover (56) has a rear opening through which the applicator body (50) can be inserted, and two slits (54a, 54b) different in depth, formed on a front end, the front end of the applying part (52) of the applicator

body (50) is cut out, forming two applying surfaces opposing inwardly each other, the applying surfaces (58) appear from respective slits (54a, 54b) of the applicator cover (56) when the applicator body (50) is inserted in the applicator cover (56), wide enough gaps that allow a nail to be inserted through the slit (54a, 54b) between the applying surfaces (58) are formed, whereby only one side of a nail tip can be painted by the appeared applying surface (58), and, selecting one of the two slits (54a, 54b) allows for drawing lines having different widths from each other for French nails.

6. The applicator implement according to any one of Claims 1 to 4, wherein the applicator cover (56) has a rear opening through which the applicator body (50) can be inserted, and two slits (54a, 54b) different in depth, formed on a front end, outsides of the front end of the applying part (52) of the applicator body (50) are formed with two applying surfaces (58) having a distance between each other, the applying surfaces (58) appear from respective slits (54a, 54b) of the applicator cover (56) when the applicator body (50) is inserted in the applicator cover (56), wide enough gaps that allow a nail to be inserted between the slits (54a, 54b) and an exposed fabric body are created, whereby only one side of a nail tip can be painted by the facing applying surface (58), and, selecting one of the two slits (54a, 54b) allows for drawing of lines having different widths from each other for French nails.
7. The applicator implement according to any one of Claims 1 to 6, wherein the applicator body (50) is covered by a front barrel (22) located in front and the applicator cover (56) in front of the front barrel (22), the applicator cover (56) is removable from the front barrel (22), and the applicator body (50) is also removable.
8. The applicator implement according to any one of Claims 1 to 7, wherein the applicator body (50) is covered by a front barrel (22) located in front and the applicator cover (56) in front of the front barrel (22), and the applicator cover (56) and the front barrel (22) are formed integrally.
9. The applicator implement according to any one of Claims 1 to 8, wherein a material of the applicator cover (56) is a high polymer plastic or metal.

Patentansprüche

1. Applikatorvorrichtung, die die Applikation einer Applikationsflüssigkeit auf ein Zielobjekt ermöglicht, in dem ein Applizierteil (52) eines Applikatorkörpers (50), der mit der Applikationsflüssigkeit getränkt ist, in Kontakt mit dem Zielobjekt gebracht wird, mit:
 - einem Applikatorkörper (50), der mit einer flachen Applizierfläche (58) in einem Applizierteil (52) ausgebildet ist; und
 - einer Applikatorabdeckung (56), die am Applikatorkörper (50) angebracht ist, um das Applizierteil (52) abzudecken, und mit einem Schlitz (54) ausgebildet ist, der für Verbindung von außen nach innen sorgt, wobei
 - in einem Zustand, in dem die Applikatorabdeckung (56) das Applizierteil (52) abdeckt, die Applizierfläche (58) des Applizierteils (52) innerhalb des Schlitzes (54) positioniert ist, so dass die Applizierfläche (58) eine Applikationsflüssigkeit auf einen vorbestimmten Abschnitt eines Zielobjekts durch Einführen eines Zielobjekts durch den Schlitz (54) applizieren kann, **dadurch gekennzeichnet, dass**
 - eine vertiefte Stufe (60) etwa in der Mitte des Applikatorkörpers (50) in Axialrichtung gebildet ist, so dass die Stufe innerhalb eines Mantelzylinders untergebracht ist, wenn die Applikatorabdeckung (56) angebaut ist, um den Applikatorkörper (50) abzudecken.
2. Applikatorvorrichtung nach Anspruch 1, wobei der Applikatorkörper (50) durch einen Textilkörper gebildet ist, der mit Hilfe von Fasern und Harz geformt ist.
3. Applikatorvorrichtung nach Anspruch 1 oder 2, die eine Applikatorvorrichtung für French Nails ist, wobei ein vorderes Endteil des Applikatorkörpers (50) mit der Applizierfläche (58) ausgebildet ist, die sich in Axialrichtung des Applikatorkörpers (50) erstreckt, so dass eine Spitze eines Nagels durch den Schlitz (54) platziert und darauf die Applikationsflüssigkeit in einer vorbestimmten Breite mittels der Applizierfläche (58) appliziert werden kann.
4. Applikatorvorrichtung nach einem der Ansprüche 2 bis 3, wobei zusätzlich zum Schlitz (54) ein weiteres Loch zum Freilegen einer Außenfläche des Applikatorkörpers (50) für die Applikatorabdeckung (56) vorgesehen ist, so dass die freiliegende Außenfläche des Applikatorkörpers (50) zum Dekorieren des Ziels verwendet werden kann, wenn die Applikatorabdeckung (56) auf den Applikatorkörper (50) aufgepasst ist.
5. Applikatorvorrichtung nach einem der Ansprüche 1 bis 4, wobei die Applikatorabdeckung (56) eine hintere Öffnung, durch die der Applikatorkörper (50) eingeführt werden kann, und zwei Schlitz (54a, 54b) mit unterschiedlicher Tiefe hat, die an einem vorderen Ende gebildet sind, das vordere Ende des Applizierteils (52) des Applikatorkörpers (50) ausgeschnitten ist, was zwei Applizierflächen bildet, die nach innen einander gegenüberliegen, die Applizierflächen (58) von jeweiligen Schlitz (54a, 54b) der Applikatorabdeckung (56) erscheinen, wenn der Applikatorkörper (50) in die Applikatorabdeckung (56) eingeführt ist, ausreichend breite Spalte, die ermöglichen, einen Nagel durch den Schlitz (54a, 54b) zwischen den Applizierflächen (58) einzuführen, gebildet sind, wodurch nur eine Seite einer Nagelspitze durch die erschienene Applizierfläche (58) dekoriert werden kann, und Auswählen eines der beiden Schlitz (54a, 54b) das Ziehen von Linien mit voneinander unterschiedlichen Breiten für French Nails ermöglicht.
6. Applikatorvorrichtung nach einem der Ansprüche 1 bis 4, wobei die Applikatorabdeckung (56) eine hintere Öffnung, durch die der Applikatorkörper (50) eingeführt werden kann, und zwei Schlitz (54a, 54b) mit unterschiedlicher Tiefe hat, die an einem vorderen Ende gebildet sind, Außenseiten des vorderen Endes des Applizierteils (52) des Applikatorkörpers (50) mit zwei Applizierflächen (58) ausgebildet sind, die einen Abstand dazwischen haben, die Applizierflächen (58) von jeweiligen Schlitz (54a, 54b) der Applikatorabdeckung (56) erscheinen, wenn der Applikatorkörper (50) in die Applikatorabdeckung (56) eingeführt ist, ausreichend breite Spalte, die ermöglichen, einen Nagel zwischen den Schlitz (54a, 54b) einzuführen, und ein freiliegender Textilkörper gebildet sind, wodurch nur eine Seite einer Nagelspitze durch die zu ihr weisende Applizierfläche (58) dekoriert werden kann, und Auswählen eines der beiden Schlitz (54a, 54b) das Ziehen von Linien mit voneinander unterschiedlichen Breiten für French Nails ermöglicht.
7. Applikatorvorrichtung nach einem der Ansprüche 1 bis 6, wobei der Applikatorkörper (50) durch einen vorderen Mantel (22) abgedeckt ist, der vorn und die Applikatorabdeckung (56) vor dem vorderen Mantel (22) liegt, die Applikatorabdeckung (56) vom vorderen Mantel (22) entfernbar ist und der Applikatorkörper (50) ebenfalls entfernbar ist.

8. Applikatorvorrichtung nach einem der Ansprüche 1 bis 7, wobei der Applikatorkörper (50) durch einen vorderen Mantel (22) abgedeckt ist, der vorn und die Applikatorabdeckung (56) vor dem vorderen Mantel (22) liegt, und die Applikatorabdeckung (56) und der vordere Mantel (22) in einem Stück ausgebildet sind.
9. Applikatorvorrichtung nach einem der Ansprüche 1 bis 8, wobei ein Material der Applikatorabdeckung (56) ein Hochpolymerkunststoff oder ein Metall ist.

Revendications

1. Outil applicateur qui permet l'application d'un liquide d'application sur un objet cible en amenant une partie d'application (52) d'un corps d'applicateur (50) imprégné avec le liquide d'application en contact avec l'objet cible, comprenant un corps d'applicateur (50) formé avec une surface d'application (58) plate dans une partie d'application (52) ; et, un couvercle d'applicateur (56) qui est fixé sur le corps d'applicateur (50) pour couvrir la partie d'application (52), formé avec une fente (54) qui crée une communication d'un extérieur vers un intérieur, dans lequel dans un état dans lequel le couvercle d'applicateur (56) couvre la partie d'application (52), la surface d'application (58) de la partie d'application (52) est positionnée à l'intérieur de la fente (54) de telle manière que la surface d'application (58) peut appliquer un liquide d'application sur une partie prédéterminée d'un objet cible en insérant un objet cible à travers la fente (54),
caractérisé en ce que un degré en retrait (60) est formé dans le centre approximatif du corps d'applicateur (50) dans la direction axiale de telle manière que le degré est logé à l'intérieur d'un corps cylindrique quand le couvercle d'applicateur (56) est assemblé pour couvrir le corps d'applicateur (50).
2. Outil applicateur selon la revendication 1, dans lequel le corps d'applicateur (50) est formé par un corps de tissu auquel une forme est donnée en utilisant des fibres et de la résine.
3. Outil applicateur selon la revendication 1 ou 2, qui est un outil applicateur pour ongles français dans lequel une partie d'extrémité avant du corps d'applicateur (50) est formée avec la surface d'application (58) s'étendant dans une direction axiale du corps d'applicateur (50) de telle manière qu'un bout d'un ongle peut être placé à travers la fente (54) et se voir appliquer le liquide d'application dans une largeur prédéterminée au moyen de la surface d'application (58).

4. Outil applicateur selon l'une quelconque des revendications 2 à 3, dans lequel en plus de la fente (54), un autre trou pour exposer une surface extérieure du corps d'applicateur (50) est fourni pour le couvercle d'applicateur (56) de telle manière que la surface extérieure exposée du corps d'applicateur (50) peut être utilisée pour peindre la cible quand le couvercle d'applicateur (56) est monté sur le corps d'applicateur (50).
5. Outil applicateur selon l'une quelconque des revendications 1 à 4, dans lequel le couvercle d'applicateur (56) a une ouverture arrière à travers laquelle le corps d'applicateur (50) peut être inséré, et deux fentes (54a, 54b), différentes en profondeur, formées sur une extrémité avant, l'extrémité avant de la partie d'application (52) du corps d'applicateur (50) est découpée, formant deux surfaces d'application se faisant face vers l'intérieur, les surfaces d'application (58) apparaissent depuis des fentes (54a, 54b) respectives du couvercle d'applicateur (56) quand le corps d'applicateur (50) est inséré dans le couvercle d'applicateur (56), des espaces suffisamment larges qui permettent à un ongle d'être inséré à travers la fente (54a, 54b) entre les surfaces d'application (58) sont formés, moyennant quoi seul un côté d'un bout d'ongle peut être peint par la surface d'application (58) découverte, et, sélectionner l'une des deux fentes (54a, 54b) permet de dessiner des lignes ayant des largeurs différentes les unes des autres pour des ongles français.
6. Outil applicateur selon l'une quelconque des revendications 1 à 4, dans lequel le couvercle d'applicateur (56) a une ouverture arrière à travers laquelle le corps d'applicateur (50) peut être inséré, et deux fentes (54a, 54b), différentes en profondeur, formées sur une extrémité avant, des extérieurs de l'extrémité avant de la partie d'application (52) du corps d'applicateur (50) sont formés avec deux surfaces d'application (58) ayant une distance entre elles, les surfaces d'application (58) apparaissent depuis des fentes (54a, 54b) respectives du couvercle d'applicateur (56) quand le corps d'applicateur (50) est inséré dans le couvercle d'applicateur (56), des espaces suffisamment larges qui permettent à un ongle d'être inséré entre les fentes (54a, 54b) et un corps de tissu exposé sont créés, moyennant quoi seul un côté d'un bout d'ongle peut être peint par la surface d'application (58) faisant face, et, sélectionner l'une des deux fentes (54a, 54b) permet de dessiner des lignes ayant des largeurs différentes les unes des autres pour des ongles français.
7. Outil applicateur selon l'une quelconque des revendications 1 à 6, dans lequel le corps d'applicateur

(50) est couvert par un corps cylindrique avant (22) situé devant et le couvercle d'applicateur (56) devant le corps cylindrique avant (22), le couvercle d'applicateur (56) est amovible du corps cylindrique avant (22), et le corps d'applicateur (50) est aussi amovible. 5

8. Outil applicateur selon l'une quelconque des revendications 1 à 7, dans lequel le corps d'applicateur (50) est couvert par un corps cylindrique avant (22) situé devant et le couvercle d'applicateur (56) devant le corps cylindrique avant (22), et le couvercle d'applicateur (56) et le corps cylindrique avant (22) sont formés d'un seul bloc. 10

9. Outil applicateur selon l'une quelconque des revendications 1 à 8, dans lequel un matériau du couvercle d'applicateur (56) est un plastique haut polymère ou un métal. 15

20

25

30

35

40

45

50

55

FIG. 1

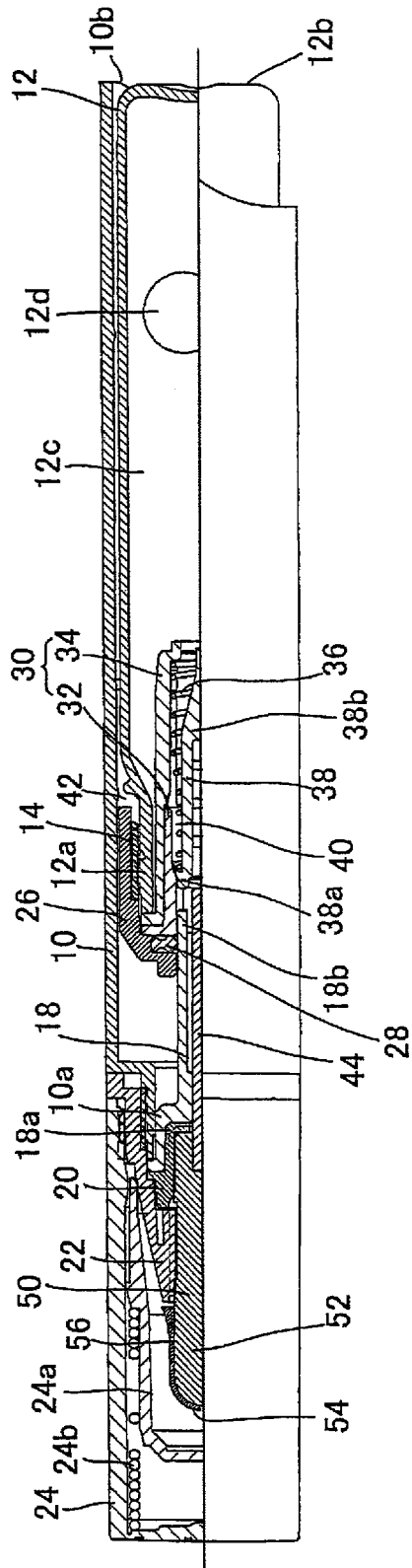
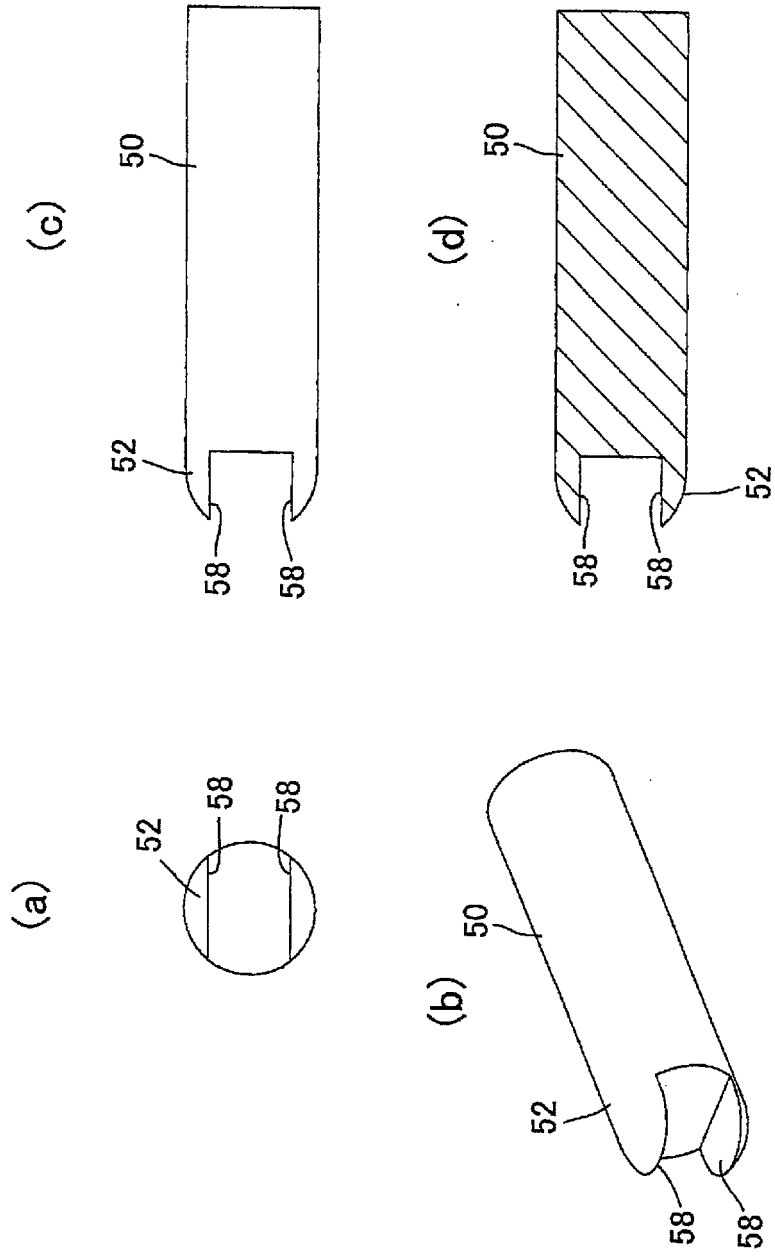

FIG. 2



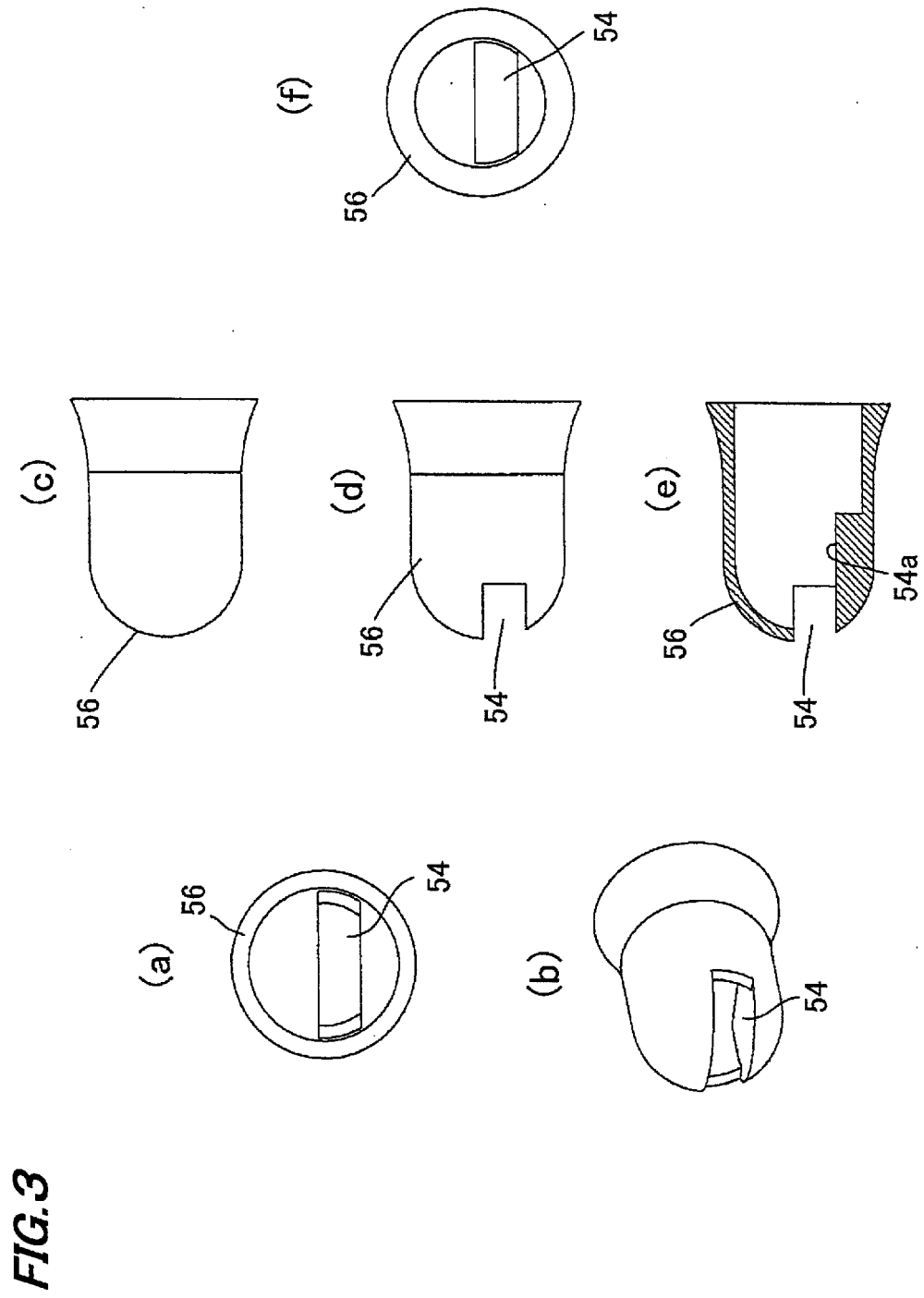

FIG. 4

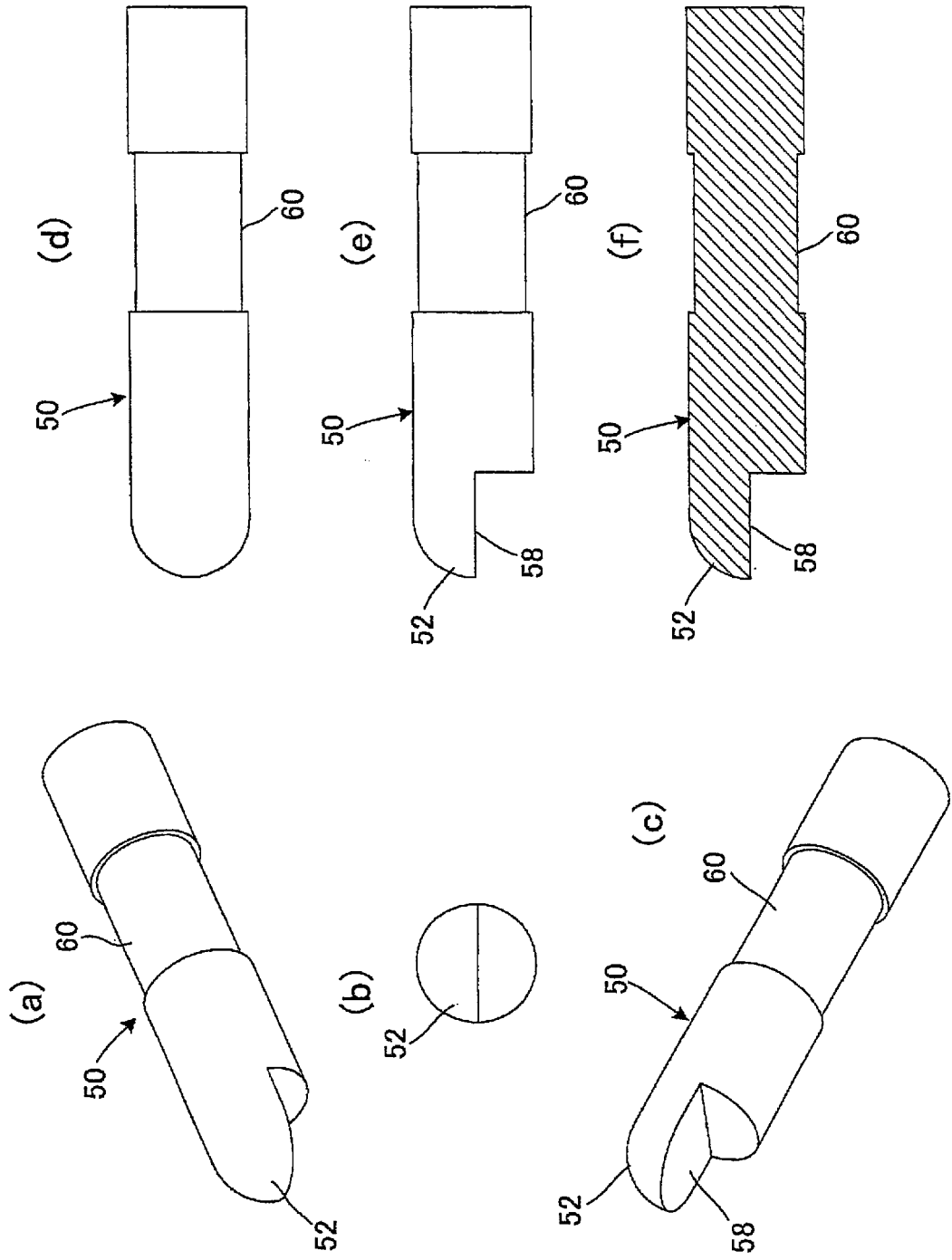
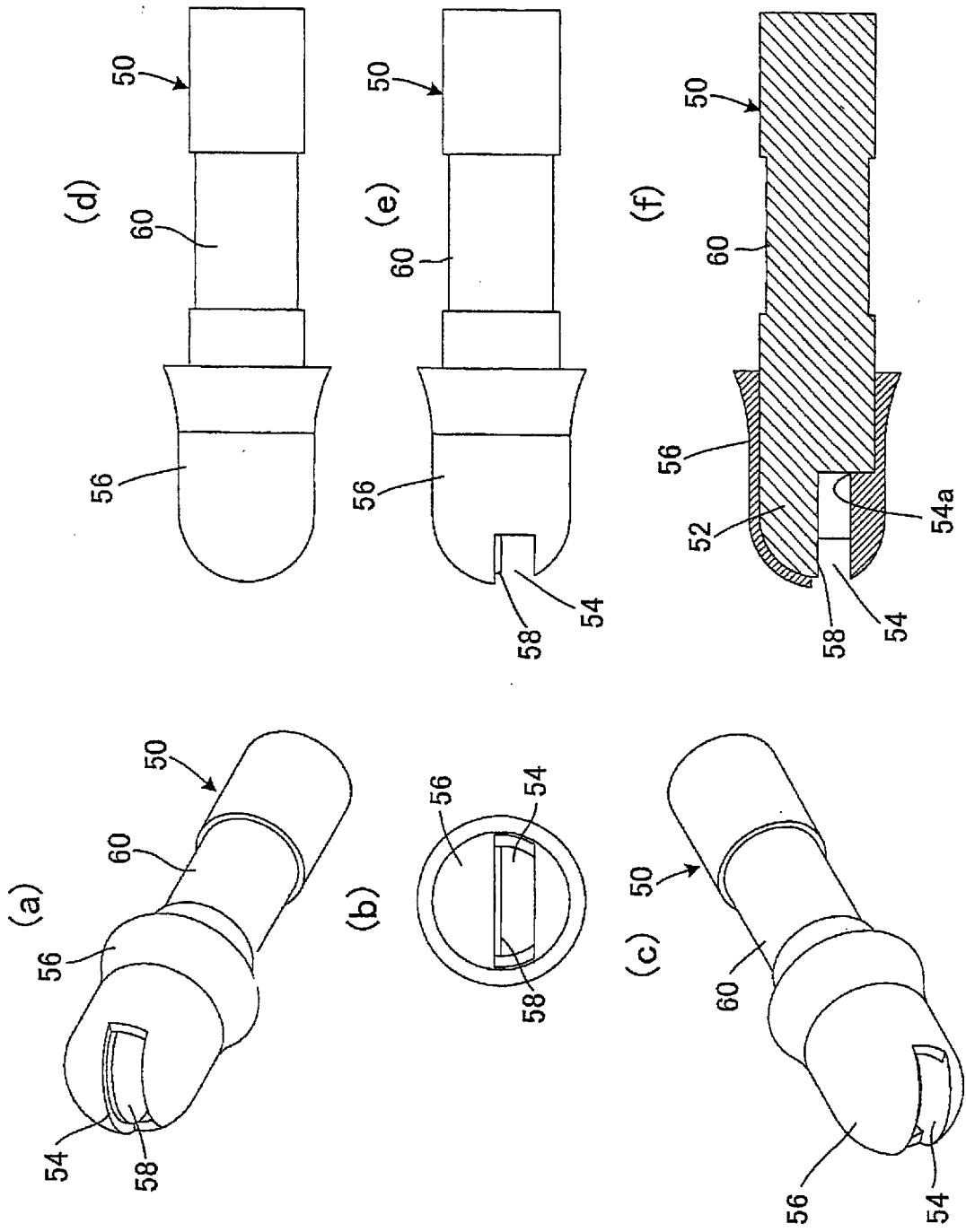

FIG. 5



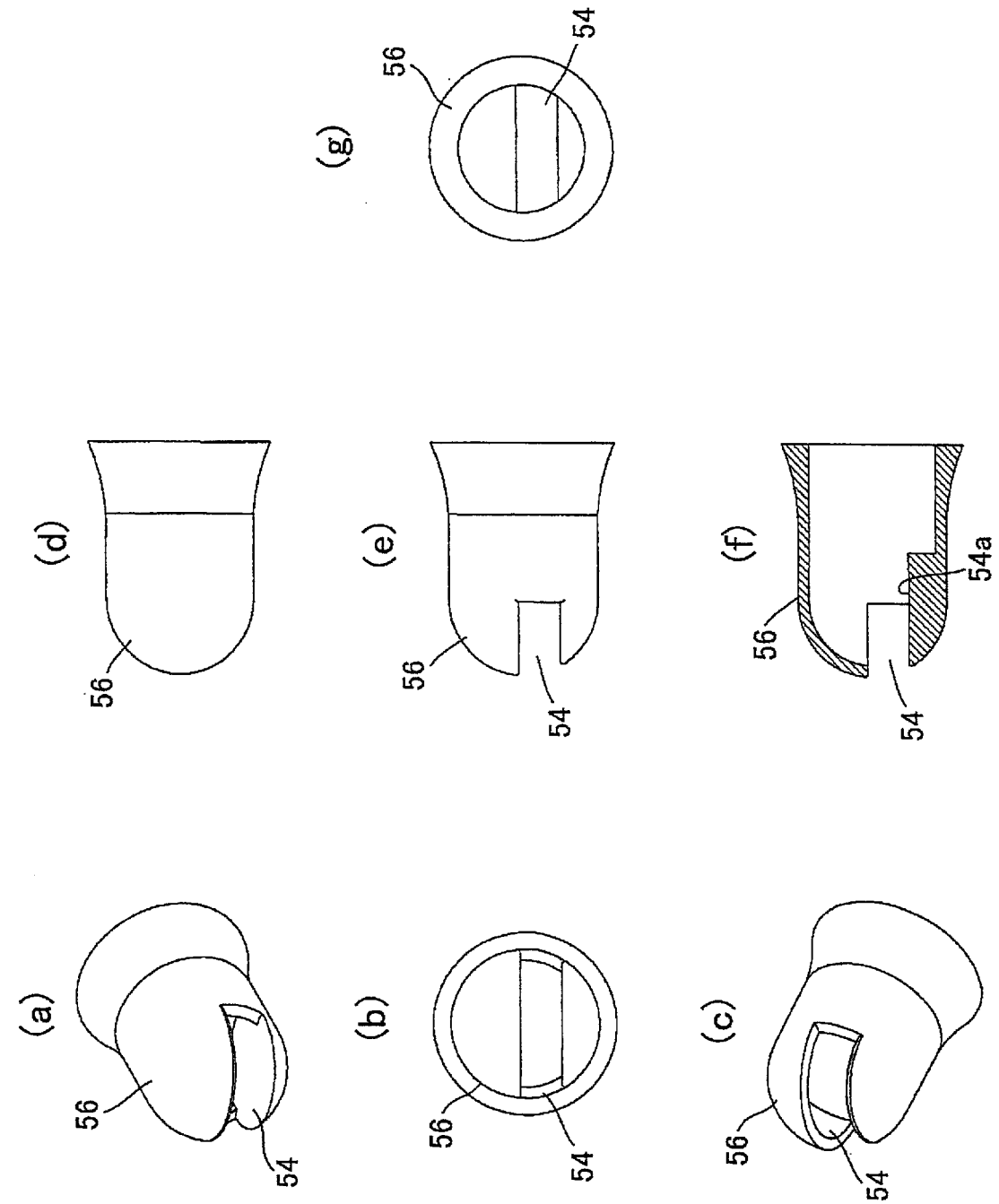

FIG. 6

FIG. 7

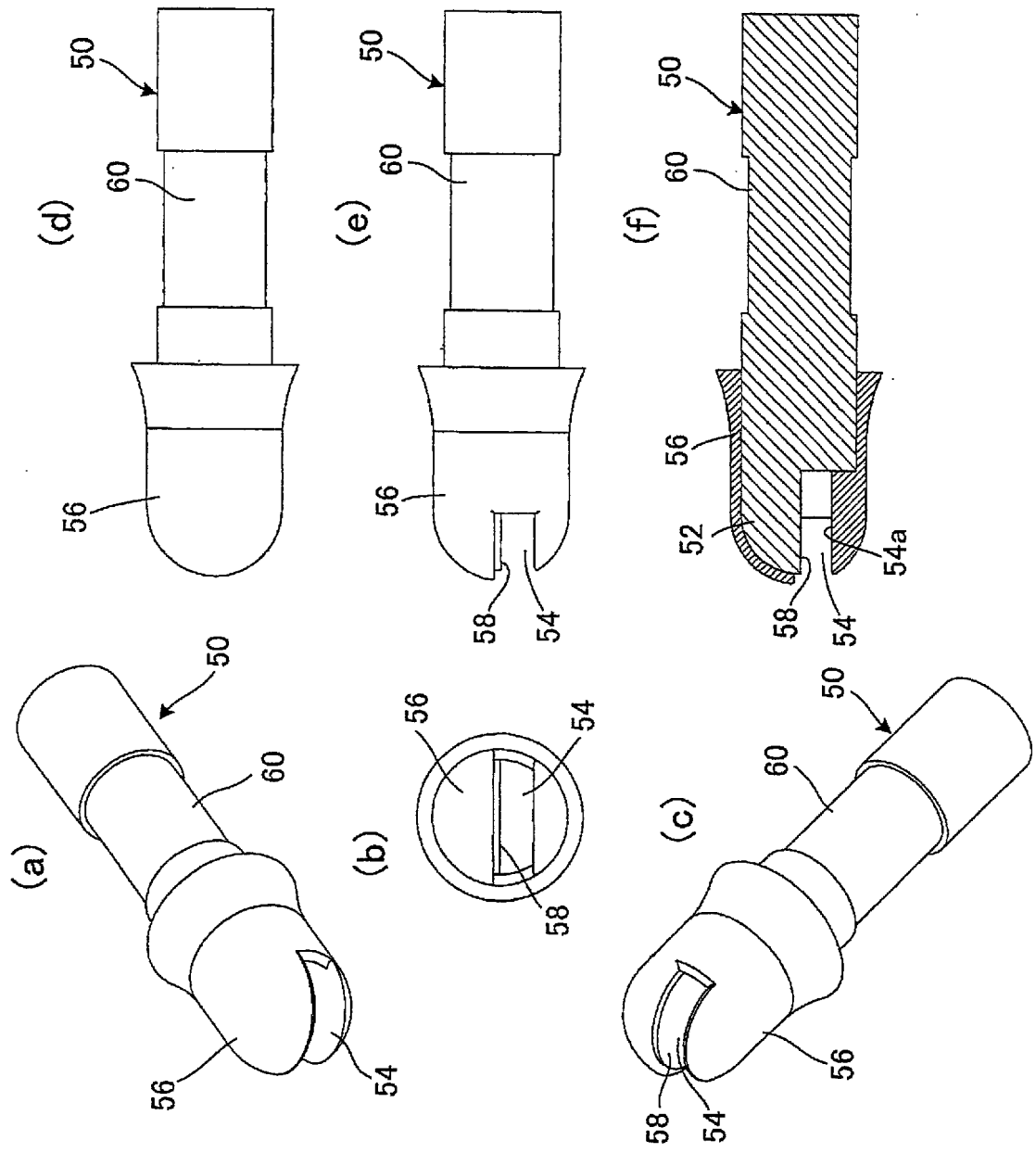
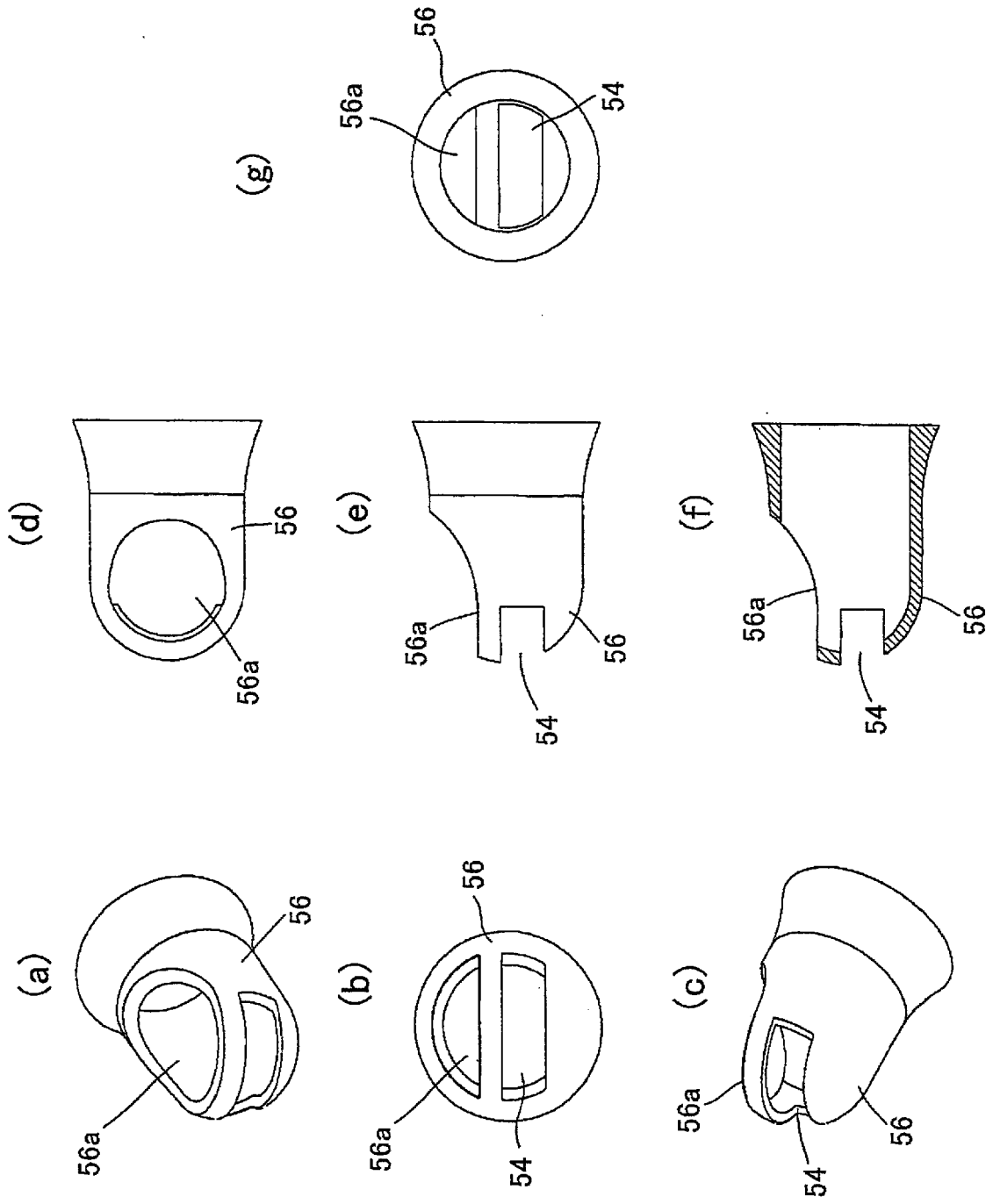

FIG. 8



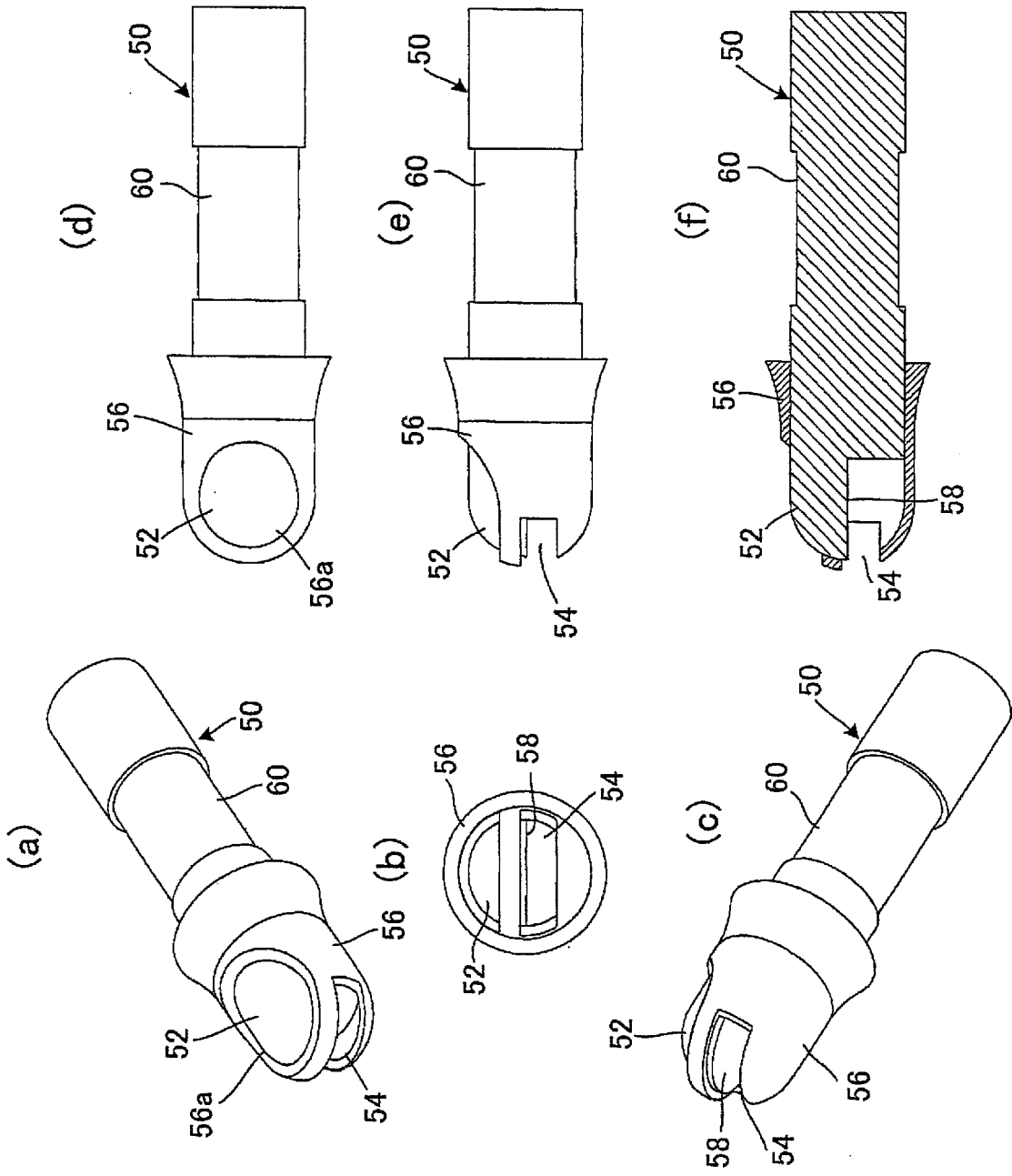

FIG. 9

FIG. 10

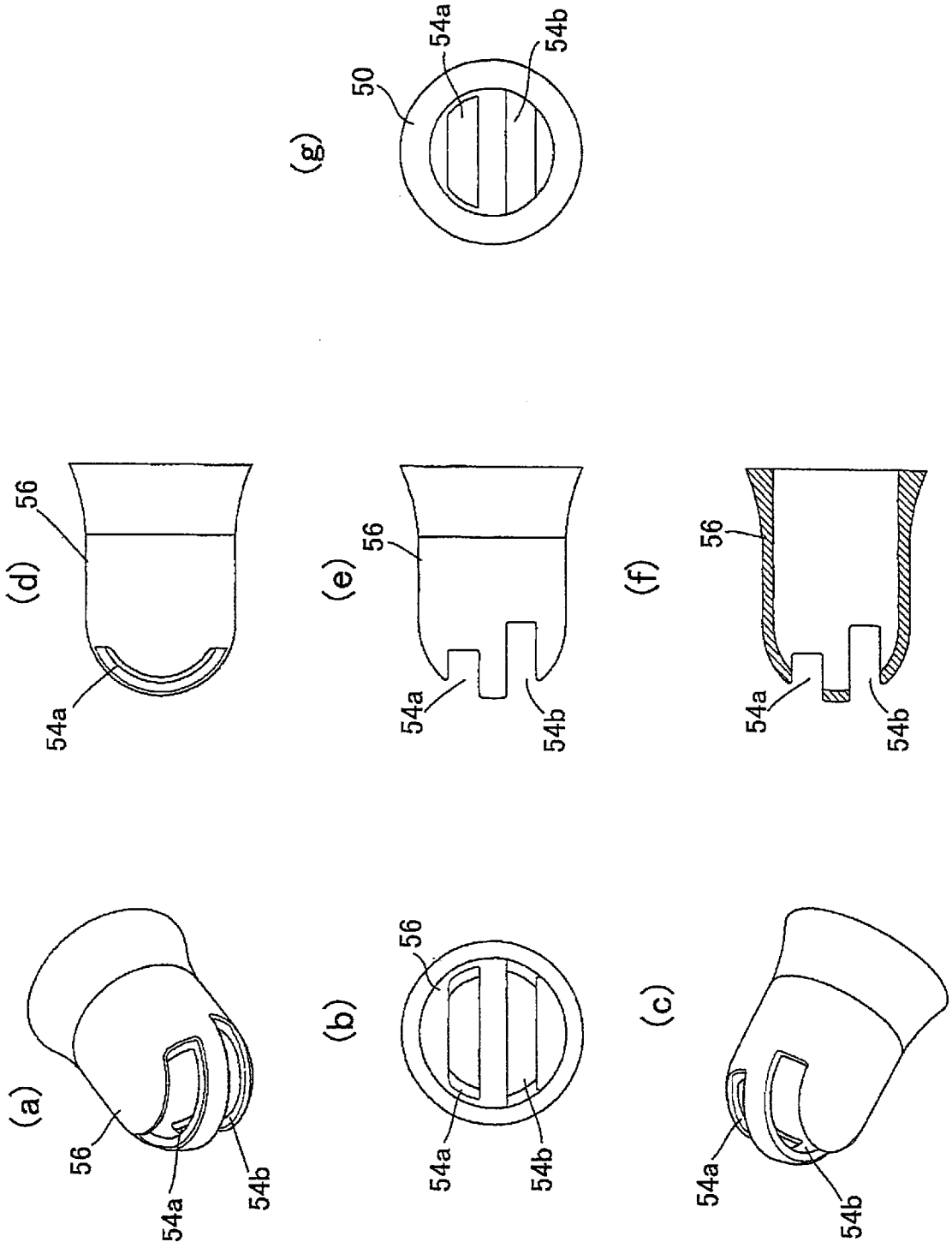
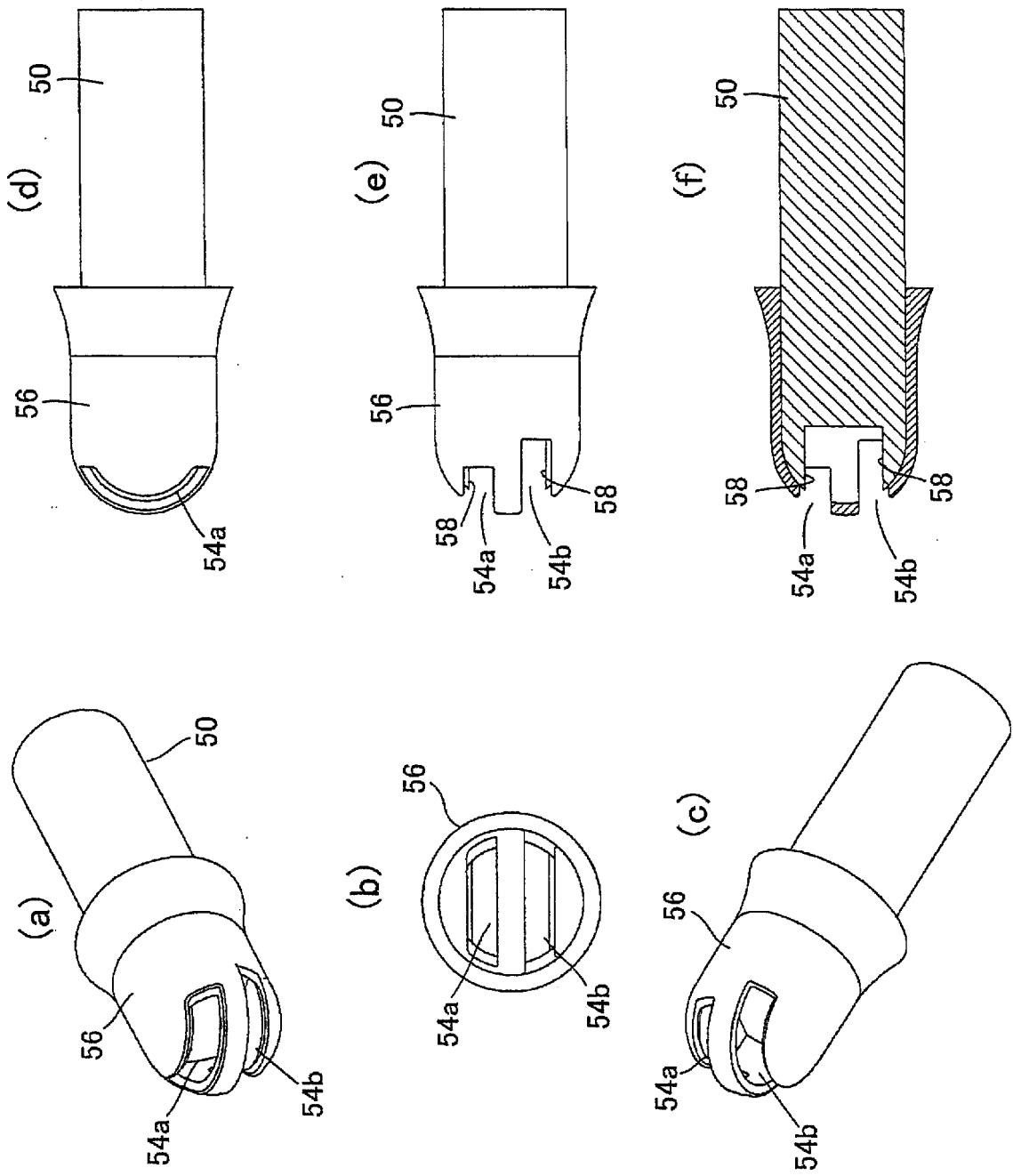

FIG. 11



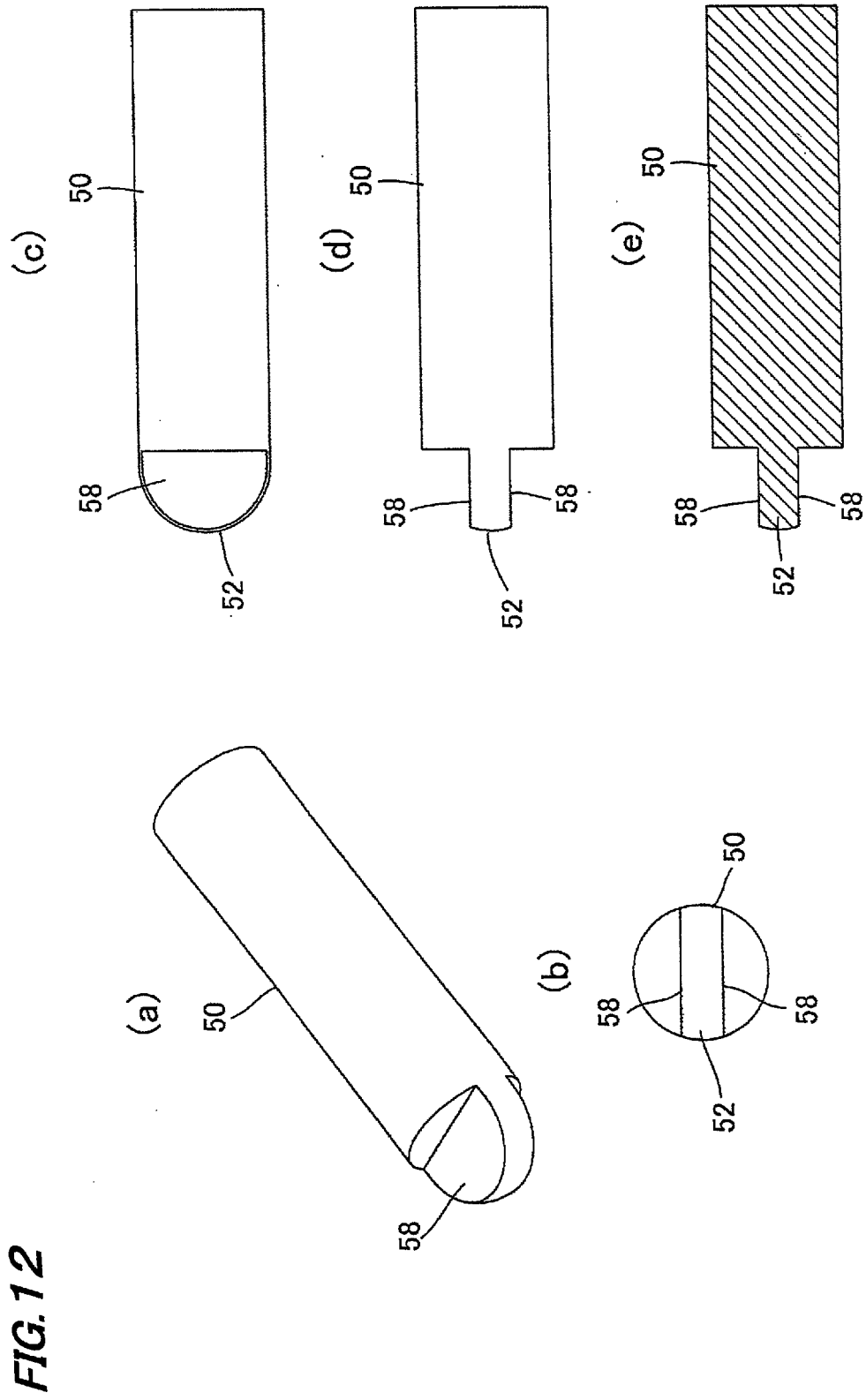

FIG. 13

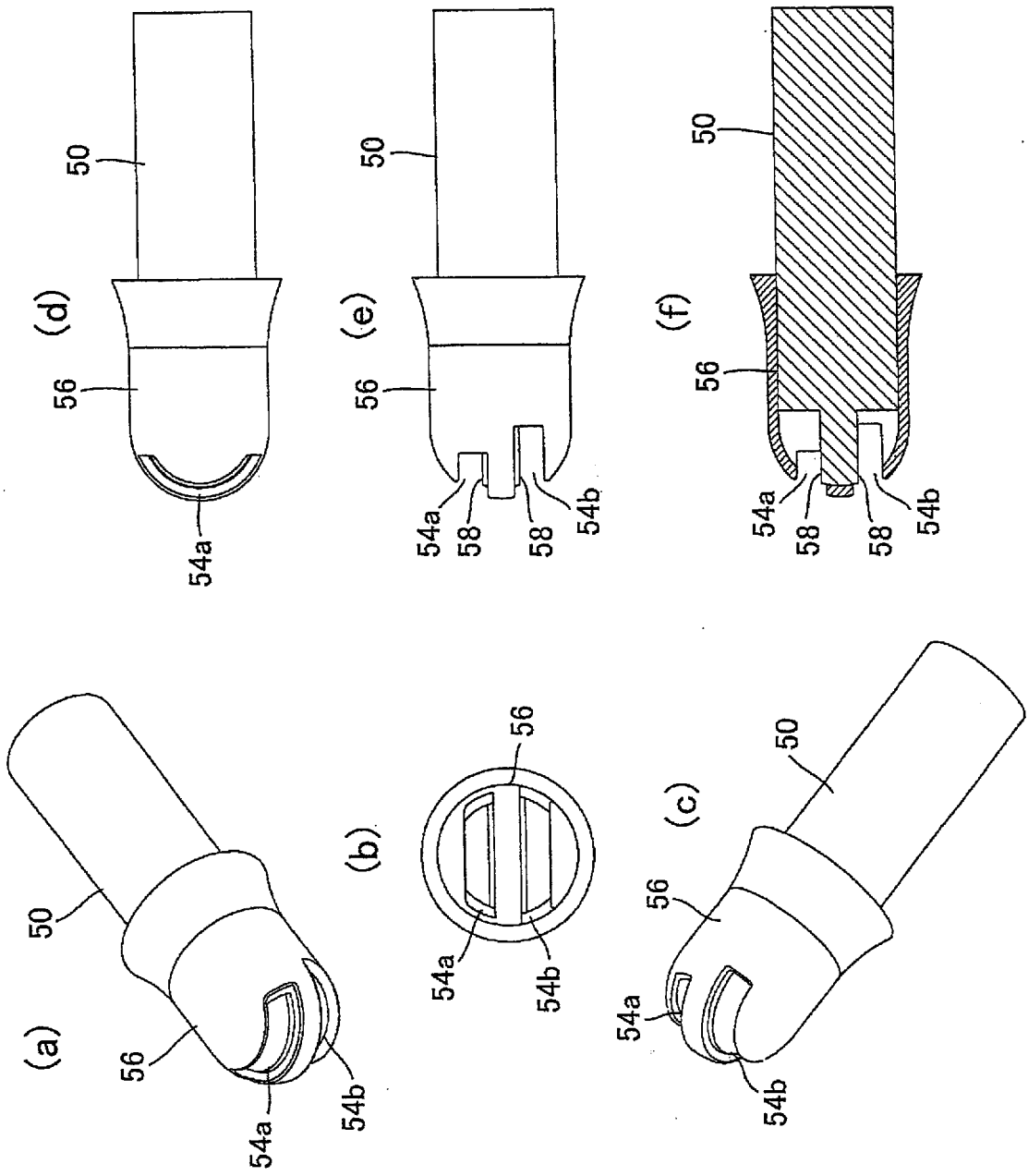

FIG. 14

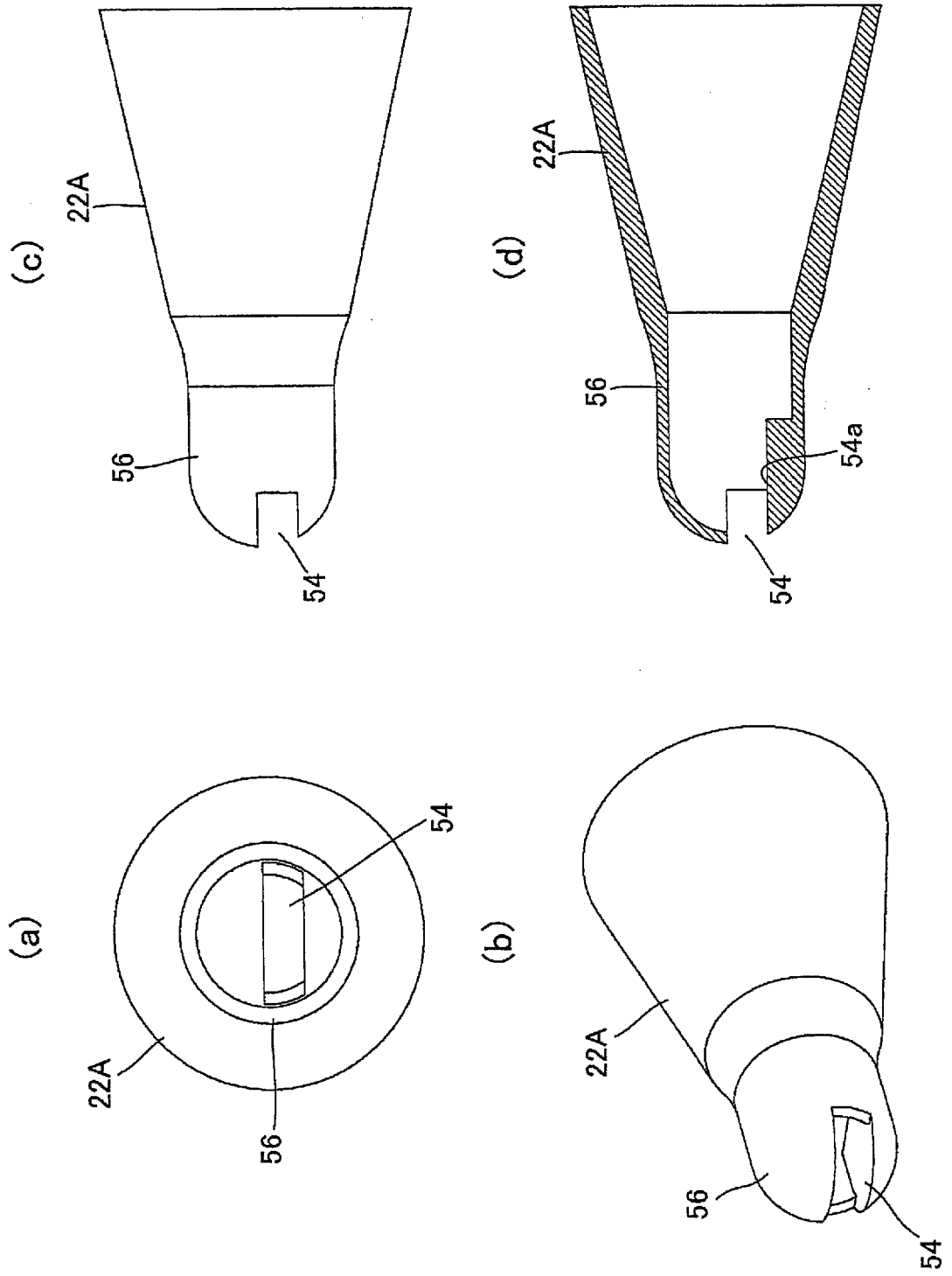

FIG. 15

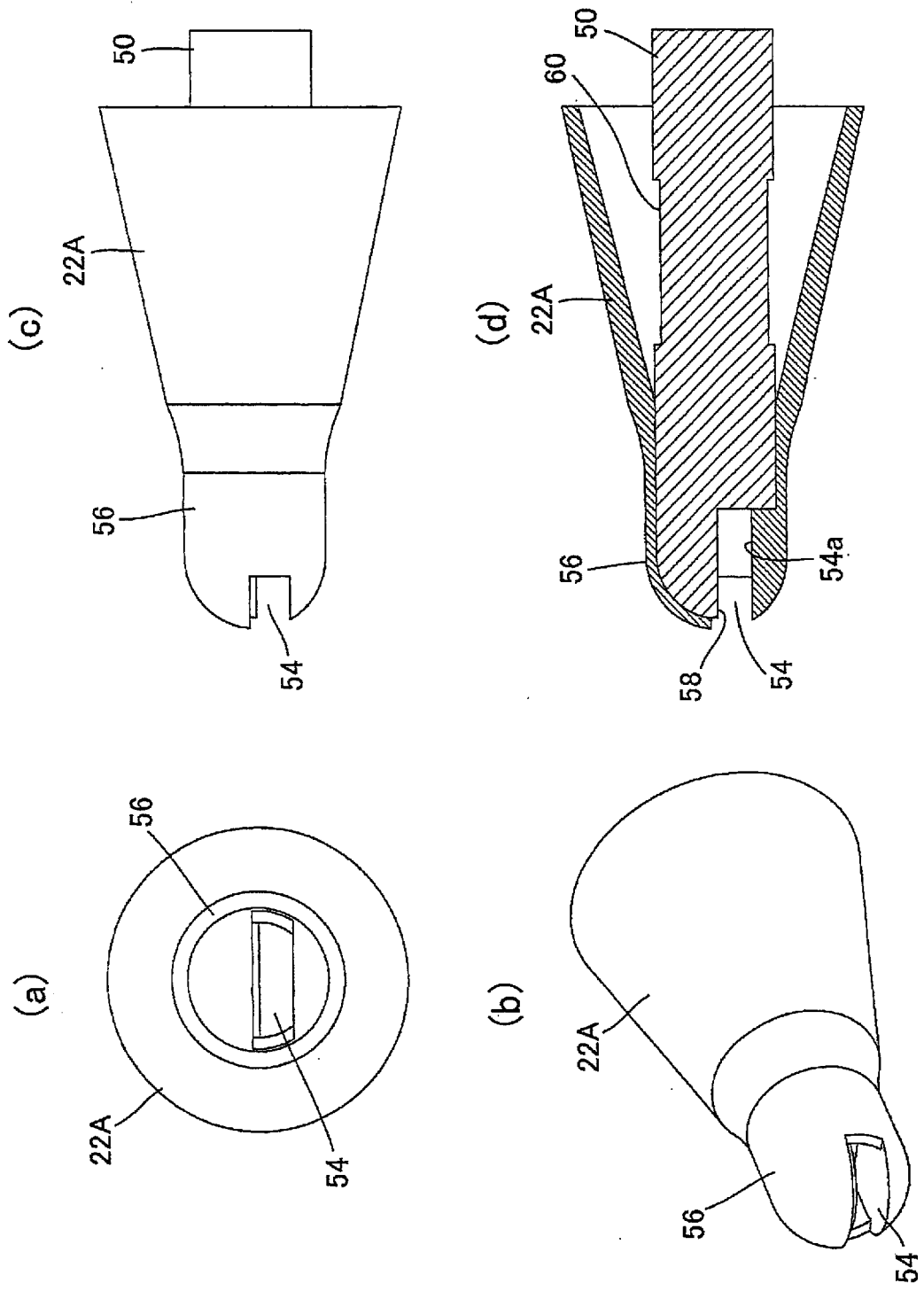

FIG. 16

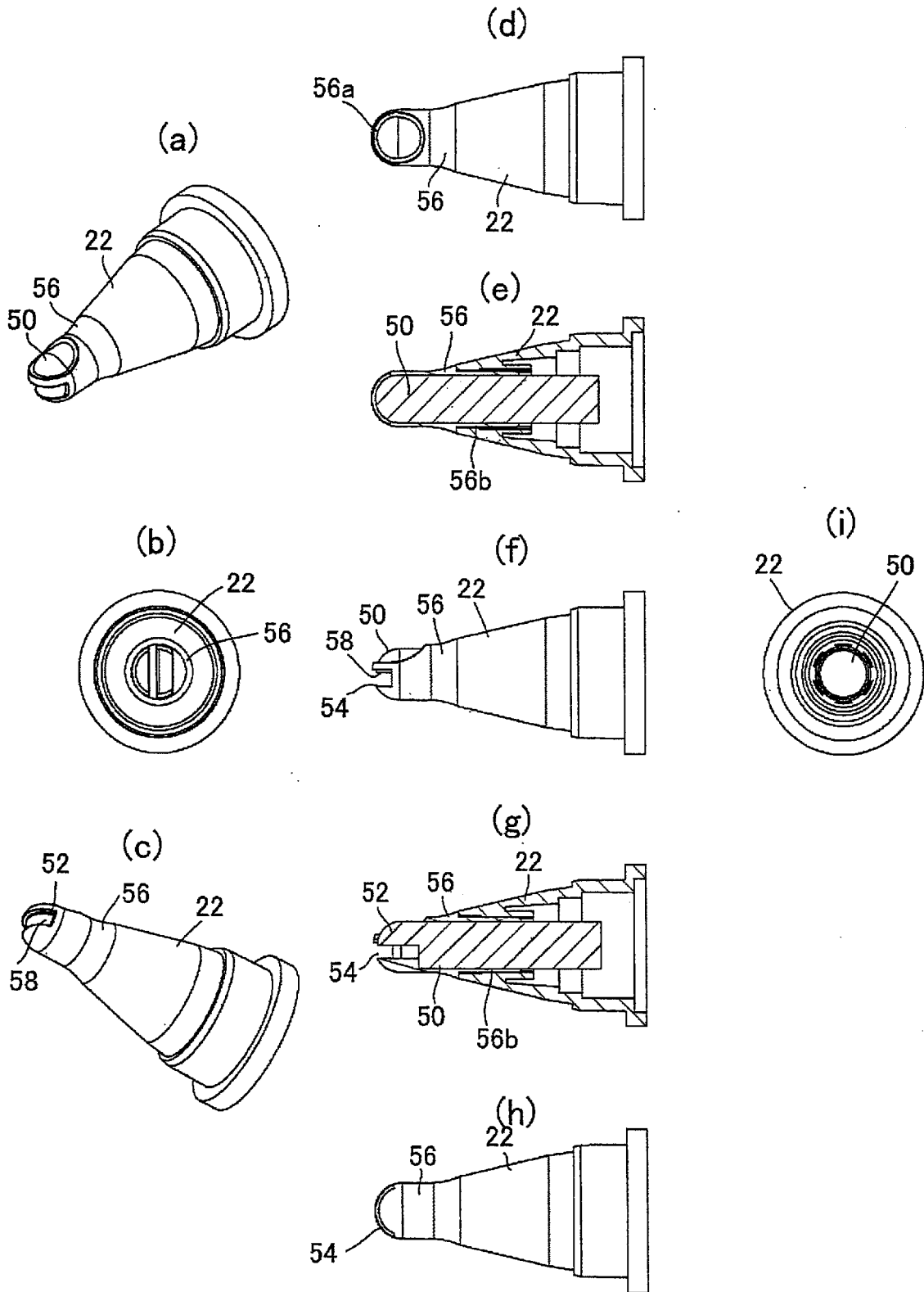

FIG. 17

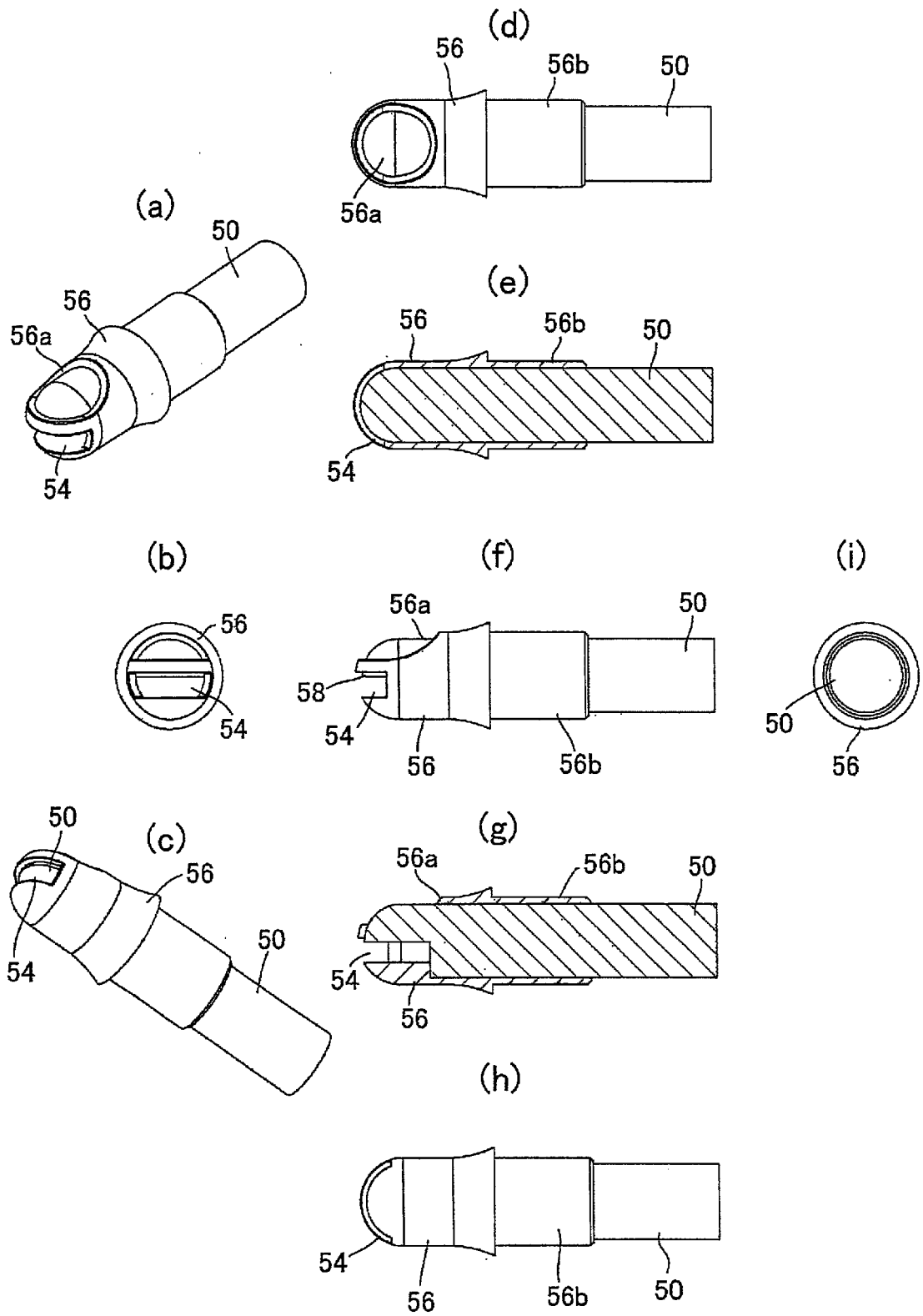
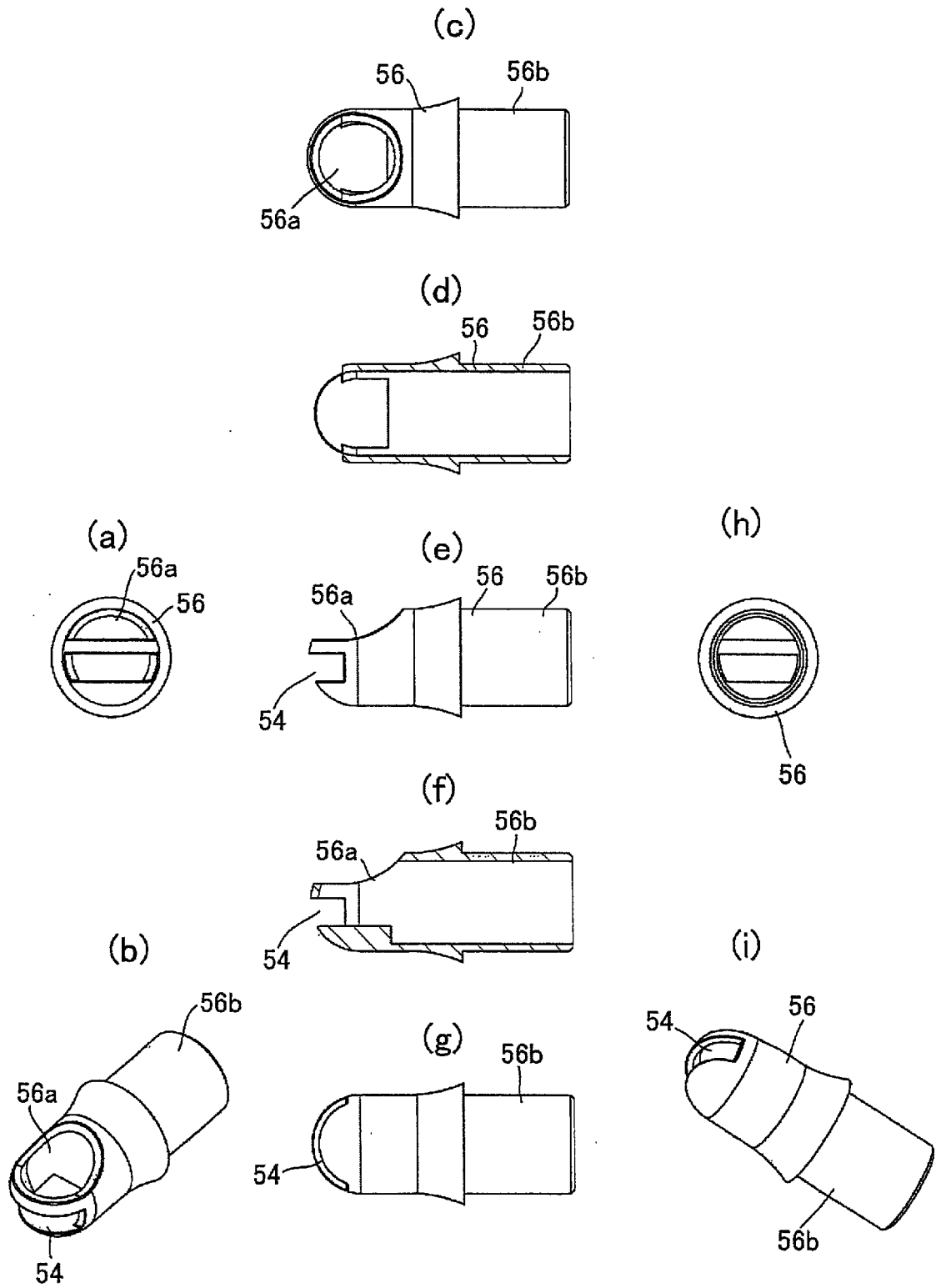

FIG. 18



REFERENCES CITED IN THE DESCRIPTION

This list of references cited by the applicant is for the reader's convenience only. It does not form part of the European patent document. Even though great care has been taken in compiling the references, errors or omissions cannot be excluded and the EPO disclaims all liability in this regard.

Patent documents cited in the description

- JP 2004059035 A [0006] [0011]
- JP 2004008826 A [0007] [0012]
- JP 2006204332 A [0008] [0013]
- JP 2006296620 A [0009] [0014]
- US 2568328 A [0010]