



(51) International Patent Classification:

B26B 21/22 (2006.01) *B26B 21/40* (2006.01)
B26B 21/14 (2006.01) *B26B 21/54* (2006.01)
B26B 21/20 (2006.01)

(21) International Application Number:

PCT/US2017/023078

(22) International Filing Date:

17 March 2017 (17.03.2017)

(25) Filing Language:

English

(26) Publication Language:

English

(30) Priority Data:

62/310,099 18 March 2016 (18.03.2016) US

(71) Applicant: **PERSONAL CARE MARKETING AND RESEARCH, INC.** [US/US]; 420 South Beverly Drive #260, Beverly Hills, California 90212 (US).

(72) Inventor: **ZUCKER, Shlomo**; 420 South Beverly Drive #260, Beverly Hills, California 90212 (US).

(74) Agent: **WELLER, Edward**; Law Office of Edward B Weller, 101 Marketside. Ave. Suite 404-401, Ponte Vedra, Florida 32081 (US).

(81) Designated States (unless otherwise indicated, for every kind of national protection available): AE, AG, AL, AM, AO, AT, AU, AZ, BA, BB, BG, BH, BN, BR, BW, BY, BZ, CA, CH, CL, CN, CO, CR, CU, CZ, DE, DJ, DK, DM, DO, DZ, EC, EE, EG, ES, FI, GB, GD, GE, GH, GM, GT, HN, HR, HU, ID, IL, IN, IR, IS, JP, KE, KG, KH, KN, KP, KR, KW, KZ, LA, LC, LK, LR, LS, LU, LY, MA, MD, ME, MG, MK, MN, MW, MX, MY, MZ, NA, NG, NI, NO, NZ, OM, PA, PE, PG, PH, PL, PT, QA, RO, RS, RU, RW, SA, SC, SD, SE, SG, SK, SL, SM, ST, SV, SY, TH, TJ, TM, TN, TR, TT, TZ, UA, UG, US, UZ, VC, VN, ZA, ZM, ZW.

(84) Designated States (unless otherwise indicated, for every kind of regional protection available): ARIPO (BW, GH, GM, KE, LR, LS, MW, MZ, NA, RW, SD, SL, ST, SZ, TZ, UG, ZM, ZW), Eurasian (AM, AZ, BY, KG, KZ, RU, TJ, TM), European (AL, AT, BE, BG, CH, CY, CZ, DE, DK, EE, ES, FI, FR, GB, GR, HR, HU, IE, IS, IT, LT, LU, LV, MC, MK, MT, NL, NO, PL, PT, RO, RS, SE, SI, SK, SM, TR), OAPI (BF, BJ, CF, CG, CI, CM, GA, GN, GQ, GW, KM, ML, MR, NE, SN, TD, TG).

Published:

— with international search report (Art. 21(3))

(54) Title: RAZOR CARTRIDGE

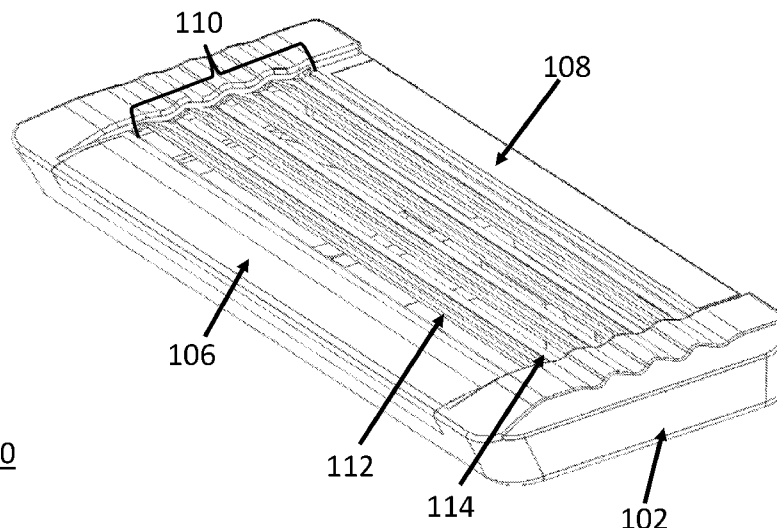

FIG 1

(57) Abstract: Disclosed here are shaving razor systems and methods including razor cartridges with a unitary frame having a length and width, a topside and an underside, wherein the unitary frame includes angled joints or bends connecting at least three guards running lengthwise on the unitary frame, the guards separated by at least three gaps in the frame, and at least three blades, affixed to the underside of the guards of the unitary frame, wherein the at least three blades include edges, and wherein the blade edges extend into the gaps in the frame when affixed to the underside of the guards of the unitary frame.

WO 2017/161341 A1

RAZOR CARTRIDGE

CROSS RELATED

[0001] This application relates to and claims priority to US Provisional application 62/310,099 filed 18 March 2016 the entirety of which is hereby incorporated.

TECHNICAL FIELD

[0002] This application relates to the field of shaving razors, razor cartridges, razor blades, frames, lubrication, and other cartridge features.

BACKGROUND

[0003] Previously, shaving razors and razor cartridges suffered from inherent drawbacks based on their razor blade arrangements. Blades did not have separate guards in place, angles of the blades were not customized for different shaving characteristics and components of the cartridge led to less comfortable shaving experiences.

SUMMARY

[0004] Systems and methods here include improved razor blade cartridges. Embodiments include shaving systems, including a unitary frame having a length and width, a topside and an underside. In some embodiments, the unitary frame includes angled bends forming at least three lengthwise guards on the unitary frame, the guards separated by at least three gaps in the frame, and at least three blades, affixed lengthwise to the underside of the guards of the unitary frame. In some embodiments, the at least three blades include edges, and the blade edges extend into the gaps in the frame when affixed to the underside of the guards of the unitary frame.

[0005] Additionally or alternatively, in some embodiments the guards include back walls that support the blades. And in some examples, the frame is made of a single piece of metal. Additionally or alternatively, some embodiments include a cartridge housing surrounding the frame leaving the blades and guards exposed, the housing including a cap. And in some embodiments, the cartridge housing includes a front guard. Additionally or alternatively, in some embodiments the cartridge housing front guard includes a lubrication strip. And in some

examples, the blades are affixed to the unitary frame by welds. Additionally or alternatively, in some embodiments the cartridge housing is made of a top and bottom which are configured to snap together and hold the frame. And in some examples, the front guard includes capillary tubes with lubrication soap. Additionally or alternatively, in some embodiments, the cap includes capillary tubes with lubrication soap. And in some examples, the number of guards is four and the number of blades is four. And in some examples, the number of guards is five and the number of blades is five. In some examples, the front guard is made of lubrication soap. And in some examples, the lubrication soap is slidably removable from the cartridge.

[0006] Additionally or alternatively, the blades are affixed to the underside of the unitary frame structure. Additionally or alternatively, the unitary frame is curved into a concave shape. Additionally or alternatively, the unitary frame is curved into a convex shape. In some examples, the blades in the cartridge head are perpendicular to the cartridge head itself. Additionally or alternatively, in some examples, the blades are canted from the perpendicular to impart a shearing force on a target hair. In such example embodiments, the canted blades may all be parallel to each other but not perpendicularly arranged in the cartridge head, rather, positioned in a canted arrangement. In some example embodiments, the canted blades may be grouped in parallel sets which are each canted in relation to one another with each set not perpendicularly arranged in the cartridge head, rather, positioned in a canted arrangement.

BRIEF DESCRIPTION OF THE DRAWINGS

[0007] For a better understanding of the embodiments described in this application, reference should be made to the Detailed Description below, in conjunction with the following drawings in which like reference numerals refer to corresponding parts throughout the figures.

[0008] FIG. 1 is a perspective illustration of a razor cartridge according to some embodiments described here.

[0009] FIG. 2 is a cut away illustration of a razor frame and blades according to some embodiments described here.

[0010] FIG. 3 is a cut away illustration of a razor cartridge according to some embodiments described here.

[0011] FIG. 4 is another cut away illustration of a razor cartridge according to some embodiments described here.

[0012] FIG. 5 is an exploded illustration of a razor cartridge according to some embodiments described here.

[0013] FIG. 6 is another illustration of a frame and blades according to some embodiments described here.

[0014] FIG. 7 is a cut away illustration of the cartridge according to some embodiments described here.

[0015] FIG. 8 is another cut away illustration of the cartridge according to some embodiments described here.

[0016] FIG. 9 is another cut away illustration of a frame and blades according to some embodiments described here.

[0017] FIG. 10 is another cut away illustration of a frame and blades according to some embodiments described here.

[0018] FIG. 11 is another cut away illustration of a frame and blades according to some embodiments described here.

[0019] FIG 12A is a top view of an example frame before cutting and stamping according to some embodiments described here.

[0020] FIG 12B is a perspective view of an example frame after cutting and stamping according to some embodiments described here.

[0021] FIG 13A is a side-by-side diagram showing a cartridge and corresponding blade arrangement according to some embodiments described here.

[0022] FIG 13B is another side-by-side diagram showing a cartridge and corresponding canted blade arrangement according to some embodiments described here.

[0023] FIG 13C is another side-by-side diagram showing a cartridge and corresponding canted blade arrangement according to some embodiments described here.

DETAILED DESCRIPTION

[0024] Reference will now be made in detail to embodiments, examples of which are illustrated in the accompanying drawings. In the following detailed description, numerous

specific details are set forth in order to provide a sufficient understanding of the subject matter presented herein. But it will be apparent to one of ordinary skill in the art that the subject matter may be practiced without these specific details. Moreover, the particular embodiments described herein are provided by way of example and should not be used to limit the scope of the invention to these particular embodiments.

[0025] Overview

[0026] The razor cartridge embodiments described here include many of various features in any combination. Aspects of the razor cartridge include different embodiments of frame, blade arrangement, blade exposure, as well as guard aspects. Some example embodiments include an internal frame system which incorporates individual guards adjacent to portions to which blades may be affixed. **FIG. 1** shows a perspective view of an example cartridge 100 according to some embodiments described here. The cartridge 100 example includes an overall housing 102 that has a front guard 106 and a cap 108. Either or both of the front guard 106 and the cap 108 may have lubrication features built in as described in more detail herein. The cartridge 100 example includes a unitary frame 110 element which include intermediary guards 114 spaced between portions where blades 112 may be mounted to run lengthwise down the cartridge 100. The example unitary frame 110 may be configured to support any number of blades including but not limited to one blade, two blades, three blades, four blades, five blades and six blades. The non-limiting example of **FIG. 1** and throughout this description is four blades.

[0027] The geometry of the blades 112 in relation to the frame 110 and the guards 114 may include any of various arrangements as described here in order to affect the shaving experience of a user of the razor cartridge 100. A first general discussion of the frame 110 and blade 112 geometry is given below. Following this discussion are more detailed descriptions of various aspects of the razor cartridge 100 embodiments.

[0028] Geometry Examples

[0029] Three example geometry variables will be discussed that can be altered in the razor cartridge to affect a shave for a user. The three example geometry variables include gap, blade angle and blade exposure. The interplay of these variables among each other leads to trade-offs in the shaving experience. A less irritating arrangement may not be effective enough for users with tough beards. A very aggressive arrangement may be too harsh for users with sensitive skin. The embodiments described here include iterations of these three variables in multiple

arrangements to achieve different shaving goals and delivering different shaving experiences to different users as well as tuning these variable to achieve the closest, most comfortable shave possible for as many users as possible.

[0030] FIG. 2 illustrates an example cut away view of a frame 210 assembly and four individual blades 212 which are shown affixed to the frame 210. To help describe the geometry of the configuration, x, y and z axis coordinates are shown in relation to the frame 210 is indicated.

[0031] The frame 210 includes intermediate guards 214 built into the frame itself which are shown both supporting each blade 212 by a back wall 240 and affixing to each blade 212 from above. The intermediate guards 214 also provide an intermediary guard fashioned as a ridge or hump that sticks out from the frame 210 in the y direction to engage the skin when the cartridge is applied in a shaving stroke. The frame 210 example also includes angled joints 220 which connect each blade 212 and guard 214 arrangement to the next and to the cartridge itself.

[0032] The first geometry variable of discussion is a gap. A gap 270 refers to the gap between a blade edge 212 and the next adjacent guard 212, whether that be the overall cartridge front guard or an intermediate guard in the frame. The larger the gap 270, the more hair is able to fit in the gap 270 and interact with the blade edge 212. The smaller the gap 270, the less hair is able to fit in the gap, but comfort may be improved. The gap may allow wash through of water and shaving material as well.

[0033] The second geometry variable of discussion is blade angle. The blade angle refers to the angle at which the blades 212 are positioned in the cartridge and/or frame 210 and interact with the user's skin in a shaving stroke. Referring to the angle of the blades 212 to the skin of a shaving user, between 0 (parallel to skin – and the neutral exposure line 280) to 17 degrees may be considered less aggressive. Between 17 degrees up to 45 degrees may be considered more aggressive. Some example embodiments may utilize blade angles between 12 and 30 degrees, where between 12 and 17 degrees may be less aggressive and between 17 and 30 degrees may be more aggressive.

[0034] Again, a more aggressive blade angle may lead to a closer cut of hair from the skin in a shaving stroke but it may be more irritating than a less aggressive blade angle for some users. Different users with different beards and skin may prefer different blade angles. Also, different areas of the body may require different blade angles.

[0035] In some embodiments, the blades 212 may be at slightly different angles from one another. For example making the first few blades in the cartridge at a less aggressive angle because in a shaving stroke, they first interact with the skin and hairs, but the back of the frame having increasingly aggressive blade angles may increase the closeness of the shave. In some embodiments, a more aggressive blade angle is configured for the first blades and less aggressive angle is configured for the back blades. Any combination of blade angles in the frame could be configured and customized for different purposes.

[0036] The third geometry variable of discussion is blade exposure. The blade exposure refers to the exposure of the blade edges 222 in reference to a reference exposure line 280 drawn across the top of the overall cartridge. In other words, the exposure line 280 is drawn in reference to the frame 210, intermediate guards 214 as well as the overall cartridge cap 108 and guard 106 (from FIG. 1). Next, the blades 212 are affixed to the frame 210. The blade edges 222 that are affixed to the frame 210 to extend beyond the exposure line 280 result in a more exposed blade. The farther the blade edges 222 are affixed in the frame 210 set back from the exposure line 280, the less they are exposed.

[0037] The more the blade edges 222 are exposed, the more they may interact with the skin and hair in a shaving stroke and the more pressure may be applied to the skin and hair by the blades 212. The less the blade edges 222 are exposed, the less they may interact with the skin and hair in a shaving stroke. Again, as a trade-off, more exposed blades may result in a closer shave but less exposed blades may provide a more comfortable shaving stroke.

[0038] In relation to the blade angles and blade exposure, some embodiments include angled joints or bends 220 in the frame 210. These angled joints or bends 220 connect the blade 212 and guard 214 portions to the next blade 212 and guard 214. Different angled joint 220 angles may affect the blade angle and blade exposure as described below.

[0039] It should be noted that the blade arrangements could be used in conjunction with and in addition to any of the other embodiments or features described in this disclosure. Therefore, a system could be built using any combination of the features described here.

[0040] Cartridge Examples

[0041] FIG. 3 shows a side angle cut away view of an example cartridge 300. The cartridge 300 example includes a cap 308, a housing 304, and a front guard 306. Some embodiments

include a lubrication strip in the cap 308. The cartridge 300 also includes a frame 310 which is shown affixed to the housing 304 and supporting any number of blades 312.

[0042] The blades 312 are shown affixed to the underside of the frame 310 and the blade edges 322 are shown as exposed between the guards 314 of the frame 310. These exposed blade 312 edges 322 protrude through the frame 310 at specific angles in order to interact with a the skin and hair in a shaving stroke. The blades 312 could be affixed to the underside of the frame 310 in any number of ways including, but not limited to, welding, gluing, melding, snapping, riveting, strapping or other adhesive method.

[0043] The blades 312 could be made of any material. In some embodiments, the blades are made of metal such as aluminum, steel, stainless steel, iron, bronze, copper, tin or any amalgam of these or other metals. In some embodiments the blades 312 are made of plastics and/or composites. In some embodiments the blades 312 are made of a carbon fiber and/or ceramic. In some embodiments, the blades 312 may be honed to an edge and coated with any number of materials such as but not limited to chrome, polytetrafluoroethylene, plastics, paint, lacquer, or other coatings.

[0044] The front guard 306 could be made of any kind of material including but not limited to silicon, rubber, or plastic and take any shape including having waves, a matrix, bumps or other features that interact with the skin and hair in a shaving stroke. The lubrication strip in the cap 308 could be made of any kind of lubricating materials including but not limited to polyethylene oxide, polystyrene, polyethylene glycol, aloe, vitamin E, etc. to deliver lubricating material to the skin and hair after the blades 312 cut the hair in a shaving stroke. More detail on various cap and guard lubrication elements are described below.

[0045] **FIG. 4** shows another example cutaway detail view of a cartridge 400 in a perspective view. This view includes a cut away of the frame assembly 410 and the blades 412 affixed to the bottom of the frame 410 and shown exposing the blade edges 422 through the frame 410 and the intermediate guards 414 behind each blade 412. The guards 414 are shown as integral portions of the unitary frame 410 itself as will be described below. The blade edges 422 are shown spaced apart from each adjacent guards 414 forming a gap to allow wash through of water and shaving material. These guards 414 may have any kind of shape including the humped shape shown in FIG. 4. These intermediate guards 414 may interact with the skin and hair in a shaving stroke. These intermediate guards 414 are arranged between each blade edge 422 just as the front guard

406 is arranged before the first blade 490. These guards 406, 414 prepare the shaving target (e.g. the skin and hair) to be cut by the blades 412, 490.

[0046] The guards 414 may be coated with any kind of material to ease friction or aid in standing up hairs for closer cuts. Coatings may include chrome, polytetrafluoroethylene, plastics, paint, lacquer, or other coatings. Thus, the integrated frame system 410 as shown, includes at least as many guards 414 as blades 412 including a front guard 406 as well as a cap 408. The result of using intermediate guards 414 is prepared skin and hair for each blade as opposed to only the front blade 490 by the front guard 406.

[0047] The unitary frame 410 also provides strength and support for the blades 412 through its material and also through its shape. The guards 414 and back walls 440 provide a brace for the individual blades 412 as shown. This keeps the blades 412 in place and secures them in a shaving stroke. The frame 410 also supports the blades which may be affixed to the bottom of the intermediate guards 414.

[0048] The frame 410 itself may also provide strength for the system as the frame 410 may be made of one unitary material in some embodiments. In some examples, the frame is coated with paint or lubricant or plastic or polytetrafluoroethylene or other coating to ease friction of the skin and hair during a shaving stroke.

[0049] **FIG. 5** shows an example exploded cartridge assembly 500 as viewed from the side including a cap 502 and a housing 504. In between the cap 502 and housing 504, the frame 510 and the blades 512 are shown. As shown in **FIG. 5**, the blades 512 attach to the bottom or underside of the frame 510 and extend through holes that run along the length of the frame 510 as described below. The cap 502 and the housing 504 could be referred to as a top 504 and bottom 502 housing. Such housing units 502, 504 may be configured to snap together by plastic tabs and/or secured by pins and/or snap flanges and/or secured by rivets or staples. Such housing units 502, 504 may be configured to be glued together, welded or otherwise affixed to one another, and sandwich the frame 510 and blades 512 between them. In some embodiments, the top housing unit 504 may include recesses in the side walls which receive and hold the edges of the frame 510 in place. Alternative embodiments include securing the frame 510 and blades 512 into a single piece housing by bands or snap. The use of a two piece housing is not intended to be limiting and other housing examples could be used as well including but not limited to a single piece housing. In some embodiments, the top housing 504 includes wave elements 518 that

follow the overall contours of the frame 510 and blade 512 assembly. Such shapes may aid in a shaving stroke to follow the contours of the intermediary guards 514.

[0050] In some embodiments, the frame 510 is made of one integrated piece of material as described in FIG. 12A and 12B. In some embodiments the frame 510 could be made of any number of things including but not limited to, metal such as aluminum, steel, stainless steel, iron, bronze, copper, tin or any amalgam of these or other metals. In some embodiments the frame 510 could be made of plastics and/or composites. In some embodiments the frame 510 could be made of carbon fiber and/or ceramic. In embodiments where the frame 510 is made of one piece of metal, the undulations, guards 514, back walls 540 and spaces for the blades 512 to protrude, could all be stamped out of a single sheet as described in FIG. 12A and 12B. In other words, the frame 510 could start out as a flat sheet of metal and be stamped to form the single unit with guards 514 including back walls 540, portions to affix the blades 512, portions to secure fit into the housing 504 and cap 502, etc. And again, any number of blades 512 could be adhered to the frame 510 according to the various embodiments.

[0051] FIG. 6 shows a detail perspective view of just the frame 610 and the blades 612 mounted to the underside of the frame 610. In the example, the guards 614 are shown both forming a gap before the blades 612 and also providing support for the blades 612. The guards 614 may be configured to engage the skin between blades 612 to prepare the skin and hair for the next blade 612 in a shaving stroke. The blade edges 622 are exposed in the gap formed between the blade 612 and the adjacent guard 614. This exposure of the blades is the exposure variable as discussed above, which is the exposure to the skin and hair during a shaving stroke. The frame 610 in FIG. 6 also shows the back walls 640 which form the back walls of the guards 614 and interact with the non-sharpened end of the blades 612 to help hold them in place and support them.

[0052] FIG. 6 also shows angled joints or bends 620 on the frame 610. These angled joints or bends 620 form the side walls of the gap between the blade edges 622 and the next respective adjacent guard 614. The angled joints or bends 620 may also help determine the angle of the blade 612 in relation to the overall frame 610, depending on how the angled joints or bends 620 are configured. In some embodiments, the angled joints or bends 620 are made of a flexible material such as spring steel, plastics, rubber, or are jointed to allow flexing of the frame when in

use. In some embodiments, the flexing is limited to one direction. More discussion of angled joints or bends and frames appear below and in FIGs. 11 and 12.

[0053] In some embodiments, the distance between successive blade edges 622 may be between 1.5 and 1.7 millimeters. In some embodiments, the distance between successive blade edges 622 is between 1.1 and 1.7 millimeters. In some embodiments, the distance between successive blade edges 622 is less than 1 millimeter. In some embodiments, the angle of the angled joints or bends 620 raises the blades 612 to between 16 and 22 degrees from the horizontal. In some examples, the radius of the arc made by the inter blade guards is between .1 and .4 mm. In some examples, the radius of the arc made by the inter blade guards is between .3 and .5 mm.

[0054] In some embodiments, the exposure of the blades is neutral, in other words, the blade edges 622 do not protrude beyond an imaginary line drawn between the outermost surface of the cap and guard. In some embodiments, the exposure of the blades is all negative. In some embodiments, the exposure of the blades is all positive. In some embodiments, the exposure of the blades is progressive, ranging from positive to negative or regressive, negative to positive. In some examples, as shown in FIG.s 10 and 11, the exposure between blades is arranged on a curved arc. In some embodiments, the width of each blade 612 is between 1.2 and 2.2 millimeters.

[0055] The example of FIG. 6 also shows connecting portions 630 or tabs on the frame 610. These connecting portions 630 or tabs may be located on the edges of the frame 610 and interact with the cap and housing (not shown) in order to secure the frame into the cartridge by snapping, welding, gluing or other ways.

[0056] Lubrication Examples

[0057] Referring again to FIG. 1, the cap 108 and/or guard 106 may have lubrication properties or features in them. In some examples, the cap 108 has a lubrication strip embedded into it or attached to it. In some examples, the guard 106 may have a lubrication strip embedded into it or attached to it. In some examples, the cap 108 and/or guard 106 itself is made of a lubricating material instead of attaching one to it. For example, the cap 108 and/or guard 106 may be made entirely or partially of a solid bar of shaving soap. Such soap could have lubricating properties when wetted and/or other properties such as antibacterial, fragrant, color, texture, etc. In some embodiments, the cap 108 and/or guard 106 may be replaceable. Such

replaceable parts could allow a user or manufacturer to attach a cap 108 and/or guard 106 with some properties. Replaceable cap 108 and/or guards 106 may allow for refreshing the soap bar after a some number of uses, or replacement to gain features of another kind of soap bar.

Attachment of such a replaceable cap 108 and/or guards 106 may include any kind of clamp, slide, snap, wedge, hook, lever, magnet, or other kind of mechanical attachment.

[0058] FIG. 3 shows a cut away view of the cartridge with the cap 308 and guard 306. As can be seen in the cut away view, the cap 308 and/or guard 306 could be made of any kind of lubricating material including but not limited to shaving soap as discussed above. The shaving soap could be affixed to the cartridge body by any kind of friction fit, slide or other way. For example, the soap bar could have a T shape construction that allows it to slide into the cartridge head and remain in place with friction during shave operation.

[0059] FIG. 7 shows a cut away perspective view of an example cartridge 700 with the frame 710 and blades 712 attached. The frame 710 is shown attached to the cartridge housing 704 with the blades 712 affixed to the underside of the frame 710 and the back walls 740. The blade edges 722 are shown exposed between guards 714. The front guard 706 and the cap 708 with optional lubrication properties are also depicted.

[0060] The example cartridge 700 also depicts a particular cartridge wave shape 718 in the housing 704 side walls. In this example, the cartridge shape 718 follows the shape of the intermediary guards 714 in the frame 710. Various embodiments may be made including cartridges which do not follow the shape of the guards 714 of the frame 710.

[0061] FIG. 7 also shows an embodiment with lubrication on the guard 706 in the form of openings or wells 797 formed in the guard 706 surface. Such wells 797 may be loaded with shaving soaps, gels, lubricants, etc., as described above. The example wells 797 may be any depth and retain the soap or other material until it becomes wet during shaving, and then the material may be released or liquefy, depending on the properties of the material. The example of circular wells 797 is not intended to be limiting. Any pattern of any kind of shape could be used, including but not limited to circles, squares, triangles, hexagons, waves, ovals, trapezoids, grid, spiral, etc. In some examples, the guard 706 could be made of a polymer sponge or foam with open or closed cells that is able to absorb the lubrication and/or water during a shave. In some examples, these lubrication features may be found in the cap 708 as well as, or alternatively as in the guard 706.

[0062] In some examples, the front guard 706 includes capillary tubes, arranged in the guard itself. These capillary tubes may be filled or partially filled with lubrication soap, or may interact with a lubrication reservoir in the guard itself. In use, the capillary tubes may release soap when wet and when contacted with skin and hair. Such capillary tubes may be formed from any kind of fibers arranged into tube like shapes, and draw lubrication soaps from an underside of the front guard to a surface of the front guard during use. In some examples, the cap 708 may have similar or different lubrication than the guard 706, either or both may include lubrication aspects. In some example embodiments, the intermediary guards 714 may be coated with polytetrafluoroethylene (PTFE), or other friction reducing coating, and/or may be coated in lubricating soaps.

[0063] **FIG. 8** shows another cut away perspective view of an example cartridge from the underside. The frame 810 is shown attached to the cartridge housing 804. In this view, it can be seen that the blades 812 are affixed to the underside of the frame 810 supported by the back walls 840 which include the intermediate guards 814. The front guard 806 and the lubrication strip 808 are also depicted.

[0064] In some embodiments, cartridge walls 860 are placed in the cartridge to help support the frame 810. In some embodiments, these cartridge walls 860 run perpendicular to the direction of the blades 812 and guards 814 and are integrated into the cartridge housing 804. In some embodiments, the back walls 840 interact with and are supported by the cartridge walls 860. In this way, the frame 810 is braced at various places along the length of the cartridge 800. The number of cartridge walls 860 could vary from one, two, three, four, five, six, or even more, spaced evenly or unevenly over the length of the cartridge 800.

[0065] These cartridge walls 860 could be made of any material including plastic, metal or other material. In some embodiments the material of the walls 860 may match the material of the cartridge housing 804. In some embodiments, the material of the cartridge walls 860 may match the material of the frame 810.

[0066] It should be noted that the lubrication examples could be used in conjunction with and in addition to any of the other embodiments or features described in this disclosure. Therefore, a system could be built using any combination of the features described here.

[0067] **Frame Example Details**

[0068] FIG. 9 shows a cut-away side view of an example frame 910 and blades 912 attached to it. For purposes of discussion, x, y, and z coordinates are depicted in the figure with the overall frame 910 is shown generally in the x-z plane.

[0069] The blades 912 are shown affixed to the underside of the frame 910 and interacting with, and supported by, the back walls 940. In the example frame, the back walls 940 are a continuation of the guards 914 and thereby incorporated into one unit. The angled joints or bends 920 in the frame 910 are shown in detail and the angles of these joints or bends 920 may determine the overall posture of the adjacent blade 912 in relation to the frame 910 within which it is mounted, and thereby the overall posture of the frame 910 as a whole. As discussed above, the blades 912 may have the same angle or differing angles in comparison to one another, as they are affixed in the frame 910. Progressively or regressively angled blades 912 may interact with the skin and hair differently in a shaving stroke than blades 912 angled in the same way throughout the frame 910, thereby many different examples of blade 912 angles, gaps between blades 912, posture based on the joints or bends 920 may be created using this frame 910 concept.

[0070] FIG. 10 shows an example side cut away view of a blade frame 1010 according to some embodiments that have a concave curvature 1003 to it, when viewed from the perspective of the shaving target 1001. As discussed above, in embodiments where the angled joints or bends 1020 are configured with a wide angle, the overall effect on the frame 1010 as a whole is to curve, in this example in a concave direction 1003. Such a curve may be held in place by a rigid frame 1010 and the cartridge housing (not pictured), or combination of these. In some example embodiments, the frame 1010 and/or angled joints or bends 1020 may flex when force is applied to them. In some examples, the frame 1010 may be made of a flexible material throughout, or include joints or bends 1020 which are made of flexible material. In such examples, the frame 1010 may have a flat appearance when not under pressure, but flex into a concave shape 1003 when force is applied to the frame 1010, as in a shaving stroke. In examples with a concave frame 1010 arrangement, the blade angles and gaps and guards may be differently configured than in embodiments where the frame is relatively flat or convex as described in FIG. 11.

[0071] FIG. 11 shows an example side cut away view of a blade frame 1110 according to some embodiments that have a convex curvature 1103 to it, when viewed from the perspective of the shaving target 1101. As discussed above, in embodiments where the angled joints or bends

1120 are configured with a narrower angle or are bent a particular way, the overall effect on the frame 1110 as a whole is to curve, in this example in a convex direction 1103. Such a curve may be held in place by a rigid frame 1110 and/or the cartridge housing (not pictured). In some example embodiments, the frame 1110 and/or angled joints or bends 1120 may flex when force is applied to them. In such examples, the frame 1110 may have a flat appearance when not under pressure, but flex into a convex shape 1103 when force is applied to the back or underside of the frame 1110 by some pushing mechanism 1105 such as a wedge or other structure.

[0072] In examples with a convex frame 1110 arrangement, the blade angles and gaps and guards may be differently configured than in embodiments where the frame is relatively flat or concave as described in FIG. 10.

[0073] Unitary Frame Example Details

[0074] As discussed above, in some embodiments as detailed in FIG. 9, 10 and 11, the unitary frame is a made from one piece of flat material that is cut and bent into a frame. FIG. 12A shows an example simplistic diagram of a flat piece of material which can be stamped into a frame, with solid lines 1292 drawn where cuts may be made and dashed lines 1294 where bends may be made. The shapes formed from the cuts 1292 can be bent so as to form the back walls of the frame to support the blades which may be mounted on the frame as well as the inter-blade guards. It should be noted that the actual cuts and bends in the unitary piece of material may be more nuanced and detailed than what is shown in FIG. 12, including the addition of tabs for affixing the completed frame into the cartridge head, etc.

[0075] To manufacture such a frame using one unitary flat piece of material, the cuts and bends may be made all in one step using any combination of a stamp, laser cutter, press, or other manufacturing device or process. Alternatively or additionally, injection molding may be used to create a unitary frame as well. As can be seen, the entire frame is therefore made of one piece of material. Such material may be any number of things including but not limited to metals such as steel, aluminum, brass, copper, tin, an alloy or combination of these or other metals. The frame may be made molded or stamped using plastics, resins, ceramics, or other materials as well. The thickness of the material used to cut and bend the frame could be any amount, such as but not limited to, 1 mm thick, .75 mm thick, or 1.2 mm thick. In some embodiments, the flat piece of material may have different thicknesses in different parts. For example, the middle where the blades attach may be thinner than the edges which include the bent elbow portions.

[0076] FIG. 12B shows a perspective view of the fully cut and bent, or molded frame 1290. In the cut and bent embodiments, the cuts 1292 form the shapes which are bent 1294 to form the back walls of the blade supports. As can be seen from the perspective view, in some embodiments the entire frame 1290 is also bent into a stair step manner to allow for the blades (when affixed, not pictured) to tilt upwardly for exposure, and not lay flat. In some embodiments, other features such as tabs or bends 1295 may be included in the unitary frame 1290 to be used to secure the frame into or on the cartridge head. Again, these tabs 1295 may be stamped from the unitary frame as disclosed above.

[0077] It should be noted that the unitary frame could be used in conjunction with and in addition to any of the other embodiments or features described in this disclosure. Therefore, a system could be built using any combination of the features described here.

[0078] Canted Blade Examples

[0079] In some example embodiments, the blades in the razor cartridge are not aligned 90 degrees to the edge of the frame of the cartridge, instead, they are arranged in a slightly canted manner. If the blades are slightly canted in the cartridge head itself, a normal shaving pull or stroke will place the blades at a slightly angled attack, creating a shearing force to go with the normal perpendicular cutting force, and thus may aid shaving closeness and comfort.

[0080] In order to demonstrate embodiments of such examples, it should be noted that FIGS 13A, B and C show exaggerated blade angles in order to accentuate what the actual angles may be in the system itself. The actual angles which may be used to cant blades in a cartridge head may be imperceptible to human sight without aid, but could be on the order of 1 or 2 degrees from the perpendicular. In some example embodiments, blades may be canted as described here between 1 and 3 degrees from perpendicular. In some example embodiments, blades may be canted 5 or fewer degrees from perpendicular. In some examples, the blades may be canted between 3 and 9 degrees, or could be larger such as 12 to 14 degrees. Any amount of slight canting may allow for the shearing force to be applied by the blades to the target hair. The examples here are not intended to be limiting.

[0081] For example, FIG. 13A shows an example cartridge 1300 next to an abstraction of the arrangement of the blades 1380, in this example the blades are arranged in parallel and perpendicular 1389 to the edge of the cartridge as in a typical arrangement. Thus, FIG. 13A shows the blades 1394 aligned parallel to the x axis and aligned generally perpendicular to the

direction of the intended shaving stroke 1398. This is a typical embodiment without canted blades.

[0082] FIG. 13B shows an example cartridge 1300 next to an abstraction of the arrangement of the blades 1380, and how they are arranged parallel to one another, but in this example canted slightly 1399 off of the x axis, and thus, not completely perpendicular to the direction of the shaving stroke 1398 or the sides of the cartridge itself 1300. In such an arrangement, because a user will pull the cartridge head in a shaving stroke 1398 that is based on the cartridge head itself 1300 and not the angle the blades are arranged 1380, a shearing force may be imparted on the target hair by the blades 1396 instead of or, in addition to, a head-on cutting force. This combination of shearing and cutting may make for a smoother, more comfortable shave with less irritation and/or tugging.

[0083] FIG. 13C shows an example cartridge 1300 next to an abstraction of the arrangement of the blades 1380, and how the blades are not arranged parallel to one another, but alternating, 1382, 1384. In such examples, the canted blades may be arranged in different canted alternating directions 1382, 1384 with one group of blades parallel to each other but another group of blades parallel to each other, but not to the first group of blades. The number of parallel groups is not limited to two and could be three or four. In some example embodiments, instead of groups of blades in parallel sets, there may be singular blades that are not in parallel with another group. In any of these embodiments, the differing canted blades would allow for different shearing forces to be exerted by each of the blades. In such arrangements, rather than all the blades canted the same way, they would each be different 1382, 1384 or grouped in different canted arrangements. In some embodiments, a combination of perpendicular and canted blades may be used to impart both cutting and shearing forces on the target hair.

[0084] It should be noted that the canted blade embodiments could be used in conjunction with and in addition to any of the other embodiments or features described in this disclosure. Therefore, a system could be built using any combination of the features described here.

[0085] Conclusion

[0086] The foregoing description, for purpose of explanation, has been described with reference to specific embodiments. However, the illustrative discussions above are not intended to be exhaustive or to limit the embodiments to the precise forms disclosed. Many modifications and variations are possible in view of the above teachings. The embodiments were chosen and

described in order to best explain the principles of the embodiments and its practical applications, to thereby enable others skilled in the art to best utilize the various embodiments with various modifications as are suited to the particular use contemplated.

[0087] Unless the context clearly requires otherwise, throughout the description, the words "comprise," "comprising," and the like are to be construed in an inclusive sense as opposed to an exclusive or exhaustive sense; that is to say, in a sense of "including, but not limited to." Words using the singular or plural number also include the plural or singular number respectively. Additionally, the words "herein," "hereunder," "above," "below," and words of similar import refer to this application as a whole and not to any particular portions of this application. When the word "or" is used in reference to a list of two or more items, that word covers all of the following interpretations of the word: any of the items in the list, all of the items in the list and any combination of the items in the list.

[0088] Although some presently preferred implementations of the embodiments have been specifically described herein, it will be apparent to those skilled in the art to which the embodiments pertains that variations and modifications of the various implementations shown and described herein may be made without departing from the spirit and scope of the embodiments. Accordingly, it is intended that the embodiments be limited only to the extent required by the applicable rules of law.

CLAIMS

What is claimed is:

1. A shaving system, comprising:

a unitary frame having a length and width, a topside and an underside,
wherein the unitary frame includes angled bends forming at least three lengthwise guards on the unitary frame, the guards separated by at least three gaps in the frame; and
at least three blades, affixed lengthwise to the underside of the guards of the unitary frame,
wherein the at least three blades include edges, and
wherein the blade edges extend into the gaps in the frame when affixed to the underside of the guards of the unitary frame.

2. The system of claim 1, wherein the guards include back walls that support the blades.

3. The system of claim 1 wherein the frame is made of a single piece of metal.

4. The system of claim 1 further comprising, a cartridge housing surrounding the frame leaving the blades and guards exposed, the housing including a cap.

5. The system of claim 4 wherein the cartridge housing includes a front guard.

6. The system of claim 5 wherein the cartridge housing front guard includes a lubrication strip.

7. The system of claim 1 wherein the blades are affixed to the unitary frame by welds.

8. The system of claim 4 wherein the cartridge housing is made of a top and bottom which are configured to snap together and hold the frame.

9. The system of claim 5 wherein the front guard includes capillary tubes with lubrication soap.

10. The system of claim 4 wherein the cap includes capillary tubes with lubrication soap.
11. The system of claim 1 wherein the number of guards is four and the number of blades is four.
12. The system of claim 5 wherein the front guard is made of lubrication soap.
13. The system of claim 12 wherein the lubrication soap is slidably removable from the cartridge.
14. A system comprising:
 a bent metal frame including a topside, an underside, a width and a length, the length being longer than the width,
 wherein the bent metal frame includes,
 at least three holes running partially along the length;
 at least three humps formed in the bent metal frame, corresponding to two of the three holes;
 at least three stainless steel flat razor blades having a width and a length, the length being longer than the width, each stainless steel flat razor blade having a sharpened edge along one of the lengths and a blunt side along another of the lengths;
 the at least three stainless steel flat razor blades mounted to the bent metal frame so that the sharpened edges each protrudes through one of the at least three holes.
15. The system of claim 14 wherein the bent metal frame is coated in polytetrafluoroethylene.
16. The system of claim 14 further comprising a top cartridge housing and a bottom cartridge housing, configured to secure to one another,
 wherein the bent metal frame and mounted blades are supported between the top cartridge housing and bottom cartridge housing.
17. The system of claim 16 wherein the top cartridge housing includes a front guard and cap, the front guard including lubrication soap.

18. The system of claim 17 wherein the front guard includes capillary tubes which are loaded with the lubrication soap.

19. A method of making a razor cartridge, comprising:

stamping a single flat stainless steel piece, the flat stainless steel piece having a length, a width, a top and a bottom,

the stamp forming a bent frame including,

at least three elongated flaps running parallel and partially along the length of the flat stainless steel piece, the flaps respectively cut and bent from the single flat stainless steel piece into back walls and forming at least three elongated holes in the single flat stainless steel piece;

at least three humps running parallel to the at least three elongated holes and partially along the length of the flat stainless steel piece,

wherein the humps are respectively arranged between the at least three holes; and

at least four edge tabs bent into the width sides of the bent frame.

20. The method of claim 19 further comprising,

at least three bends on the width sides of the bent frame corresponding to edges of the at least three elongated holes, the at least three bends forming the single flat stainless steel piece into a stair step shape;

welding at least three flat stainless steel blades to the bottom of the bent frame so one edge of each blade protrudes through one of the at least three elongated holes and another edge of the flat stainless steel blades rests on the corresponding back wall; and

mounting the bent frame and welded flat stainless steel blades to a top cartridge housing on the top side of the frame and a bottom cartridge housing on the bottom side of the frame.

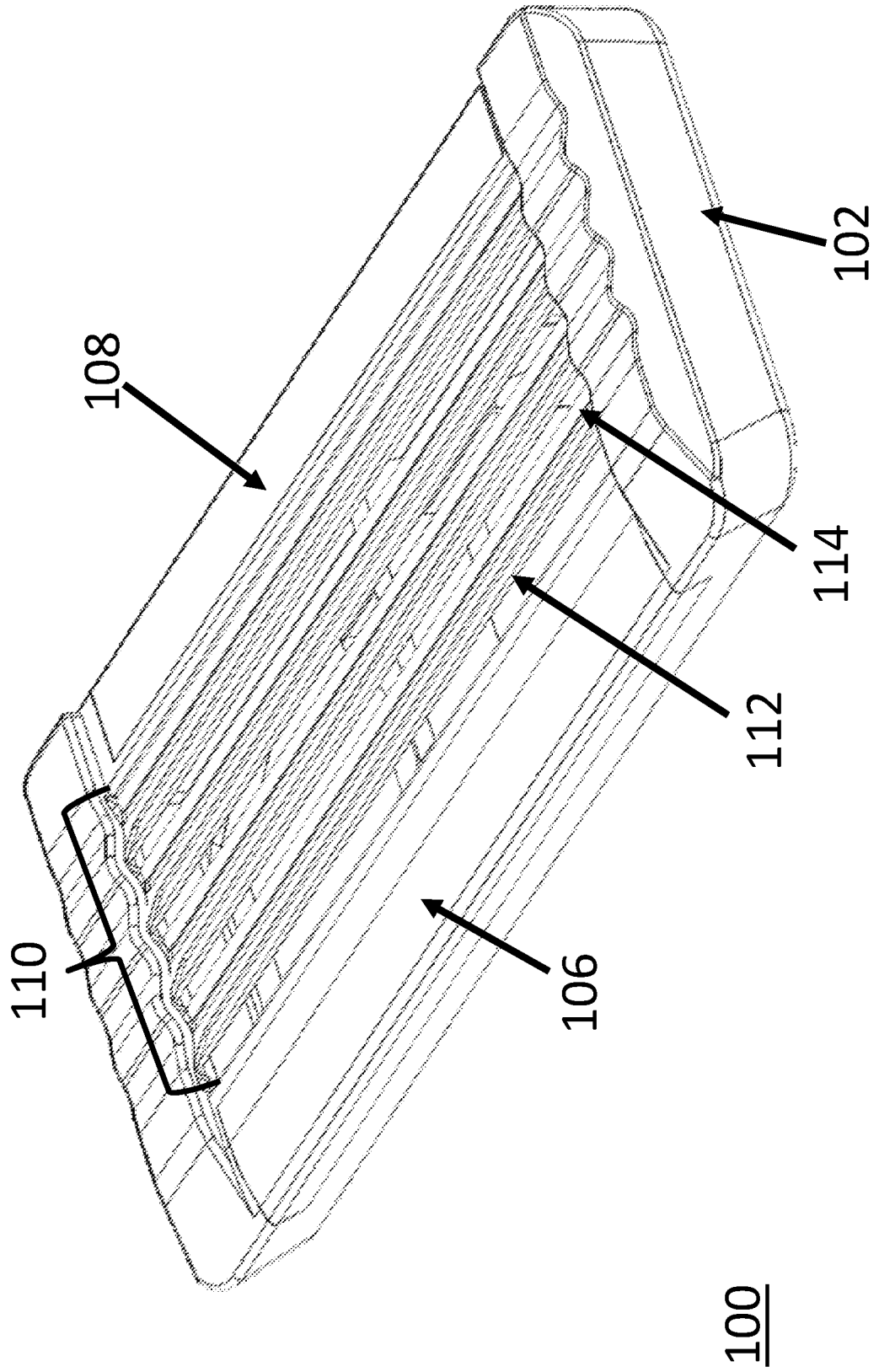

FIG 1

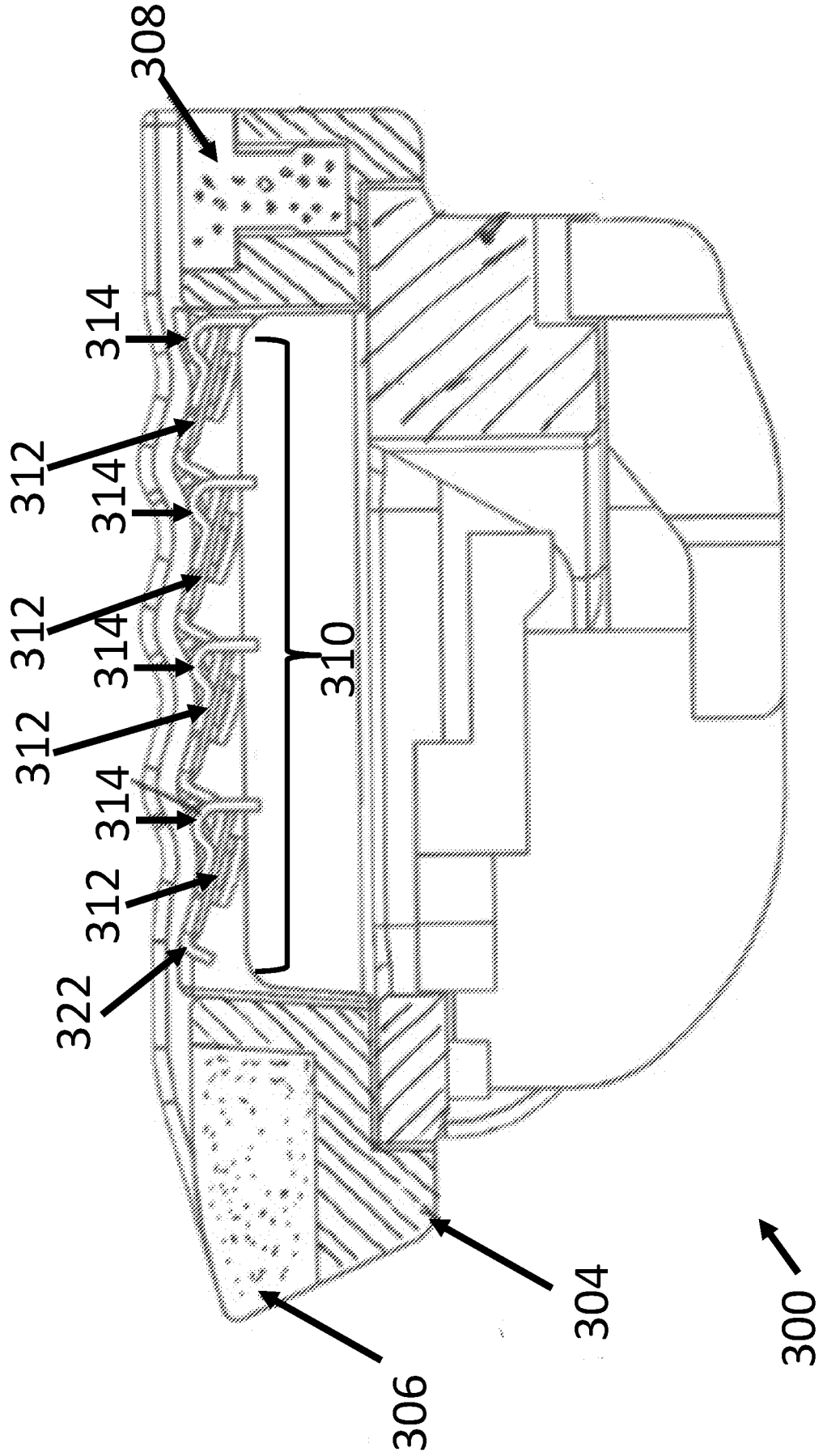

FIG 3

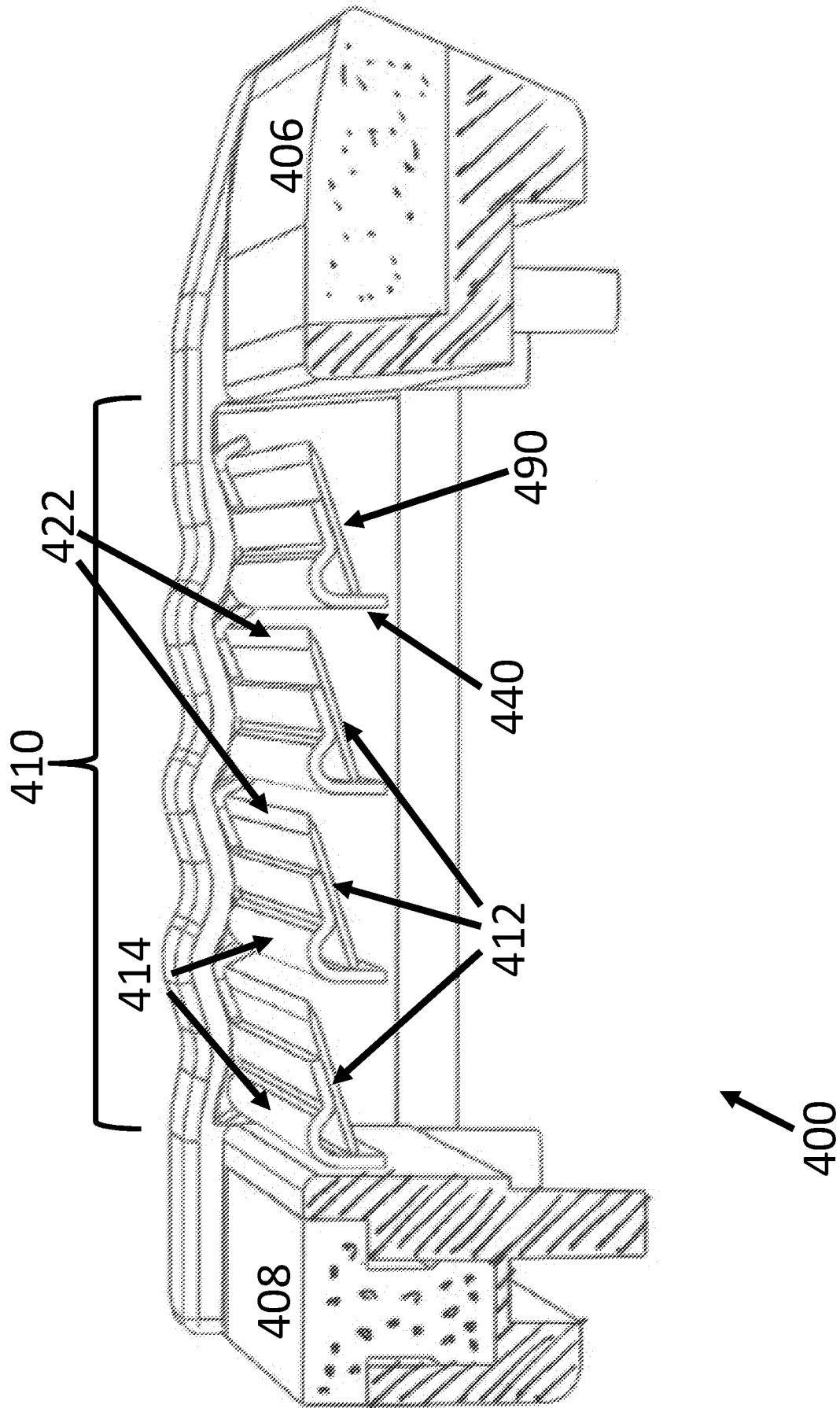

FIG 4

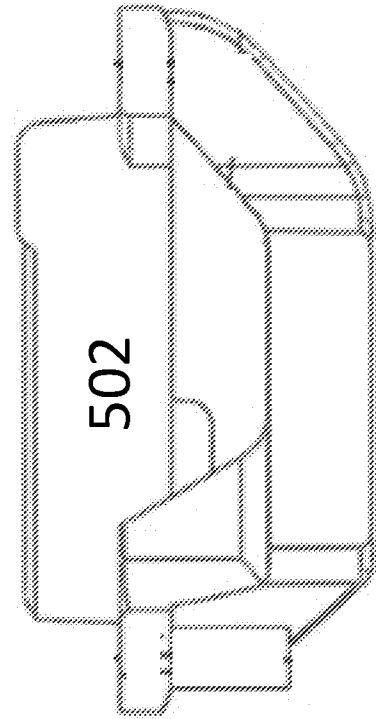
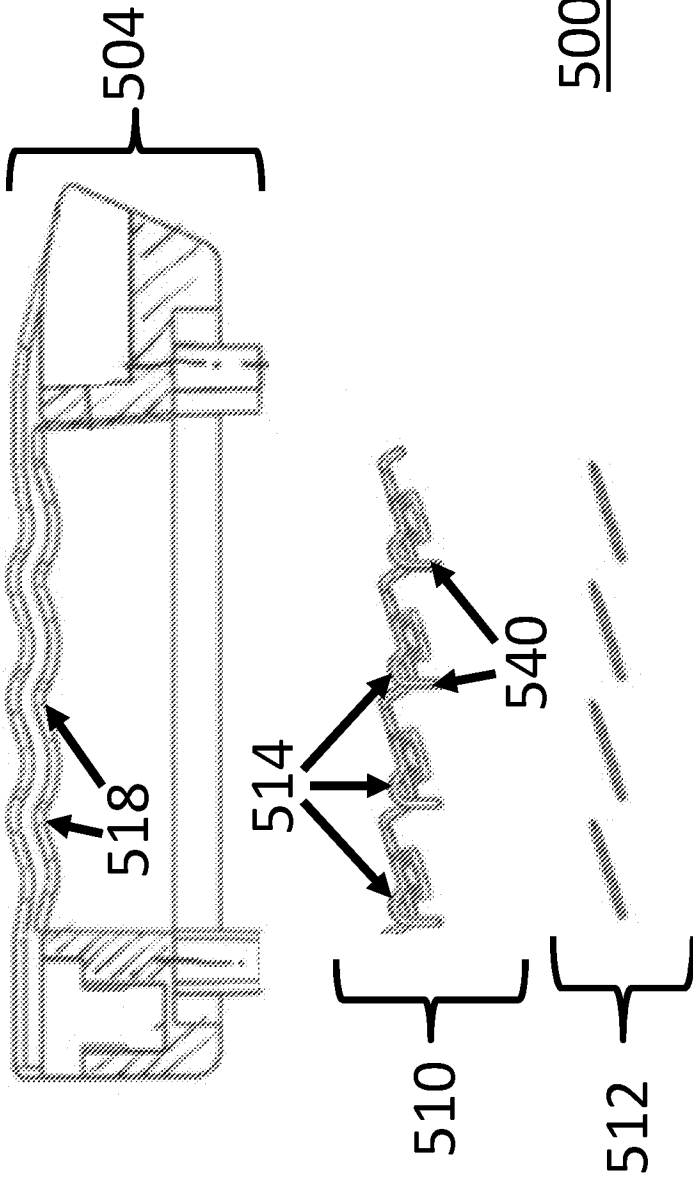

FIG 5

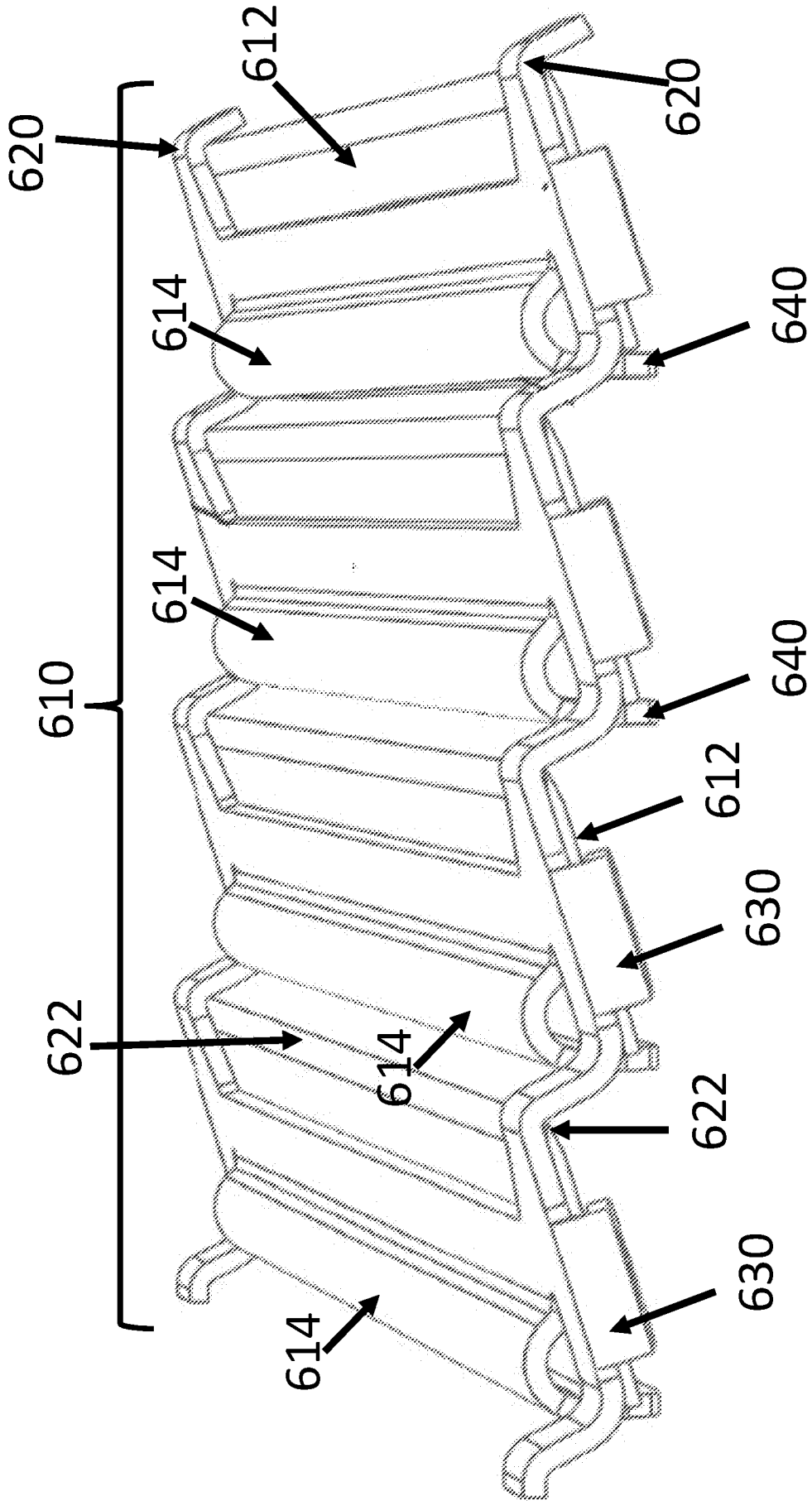

FIG 6

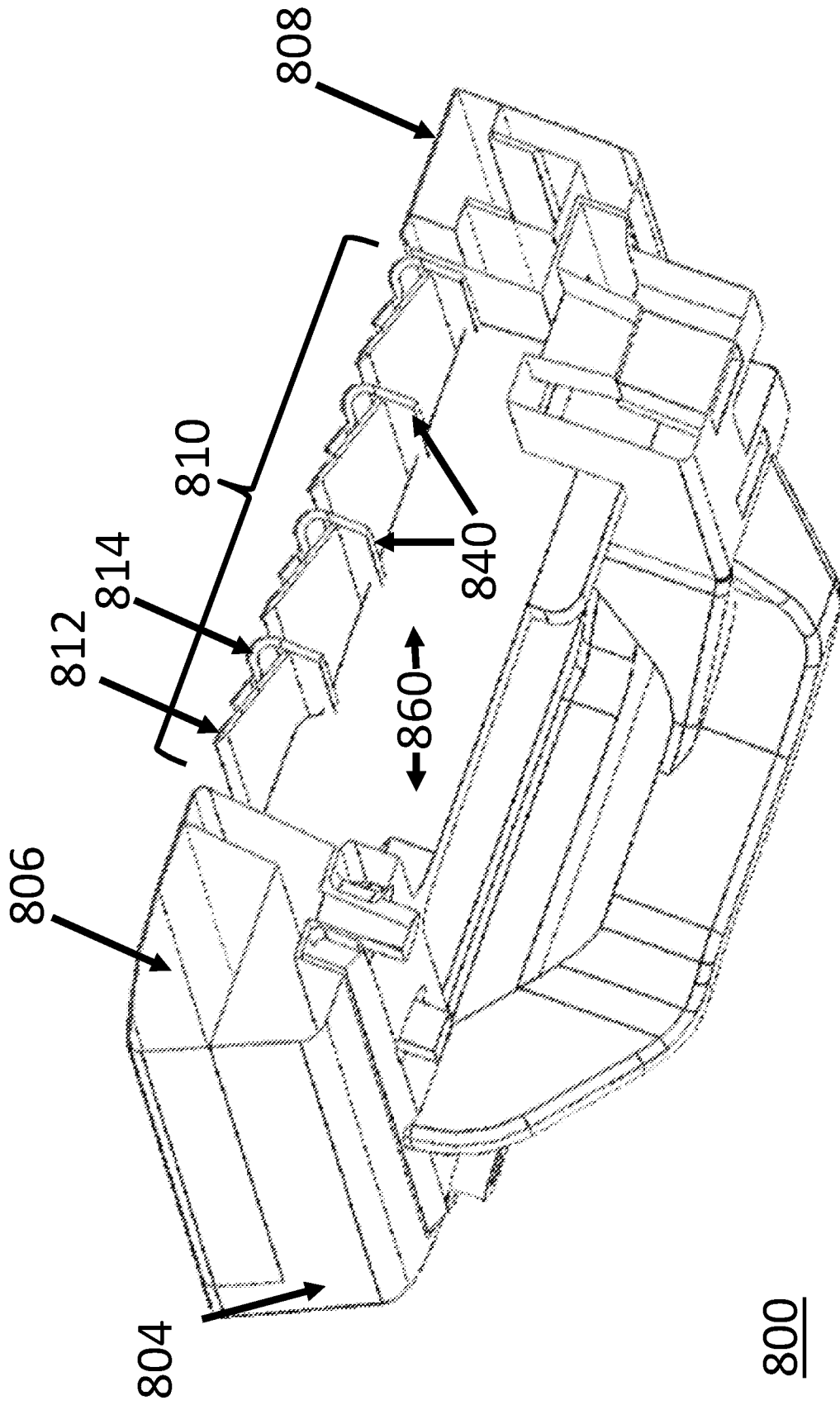

FIG 8

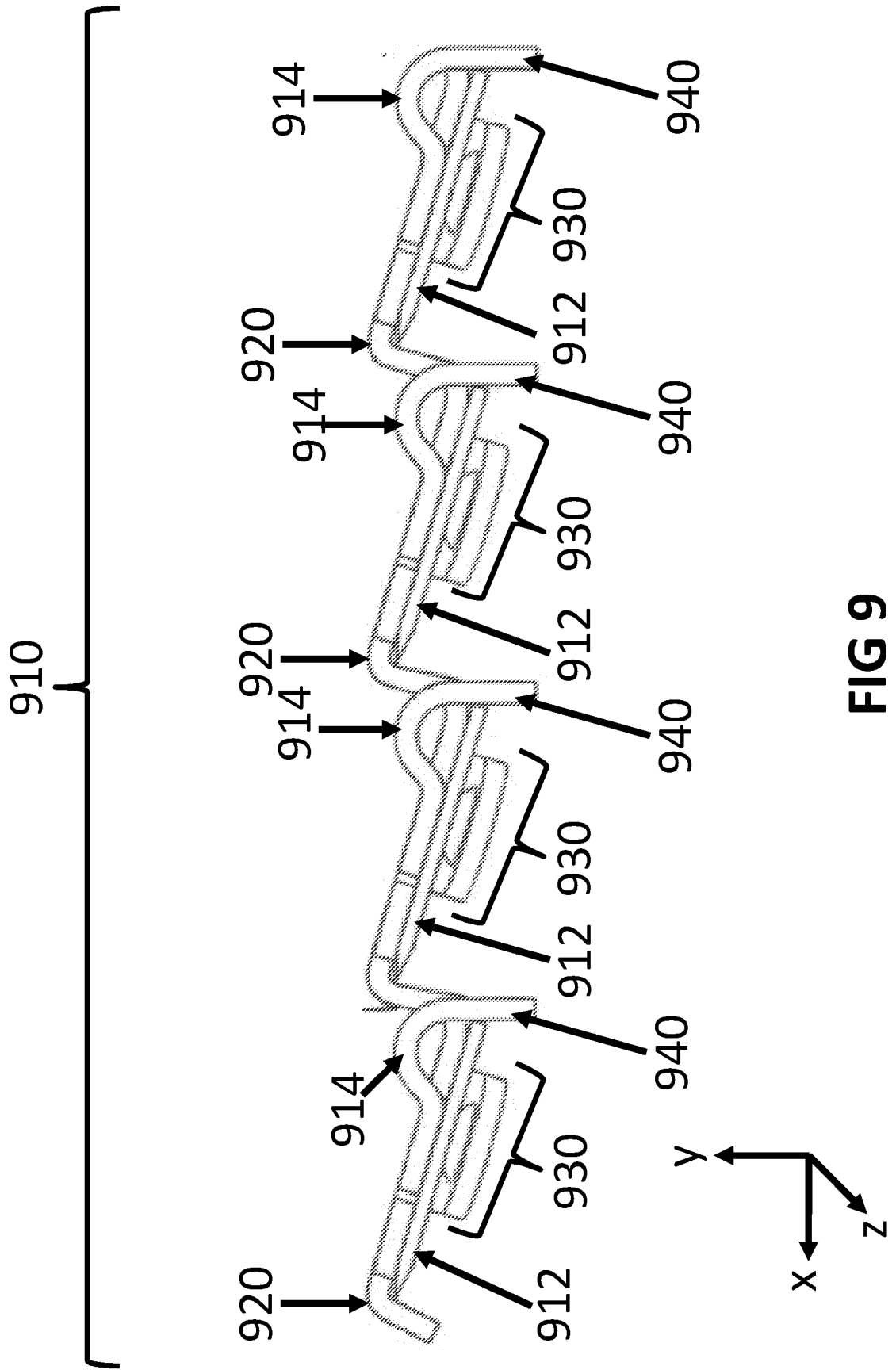

FIG 9

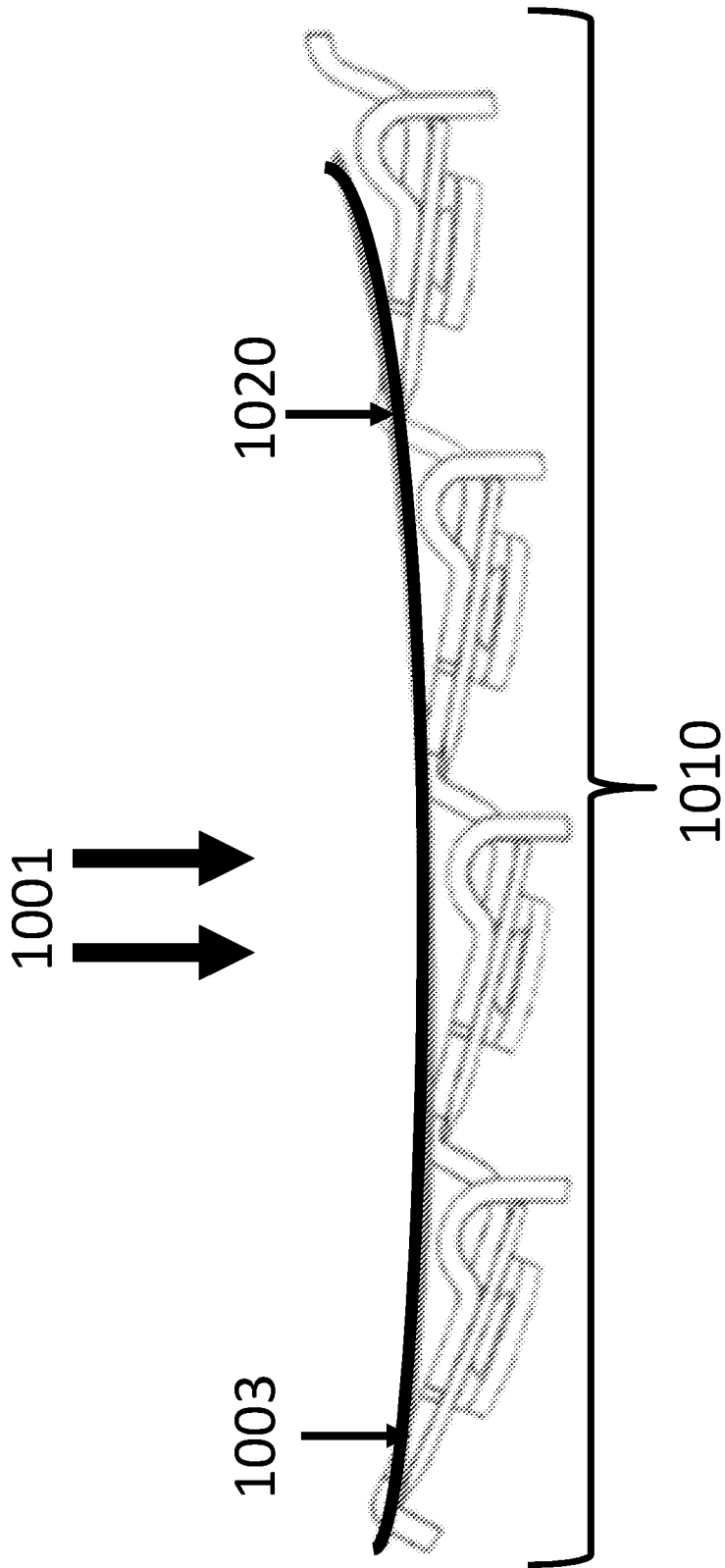

FIG 10

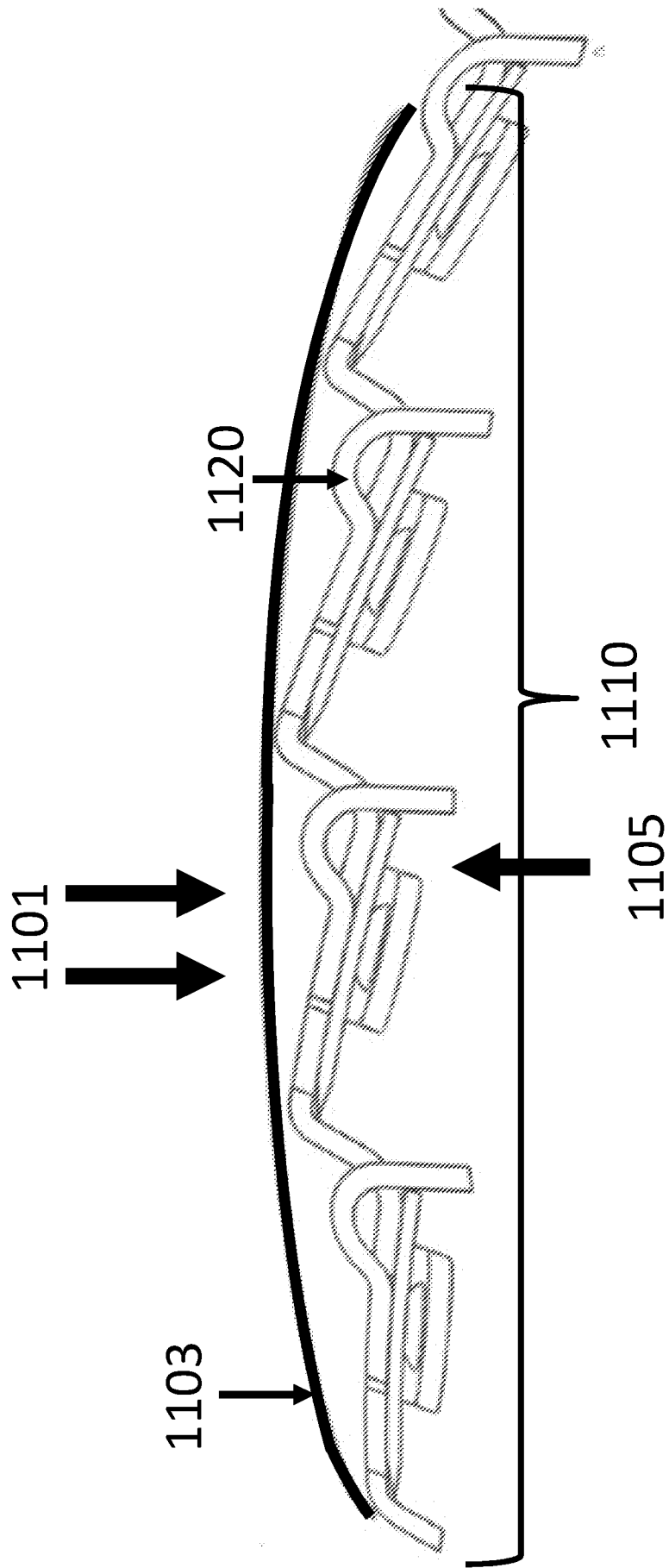

FIG 11

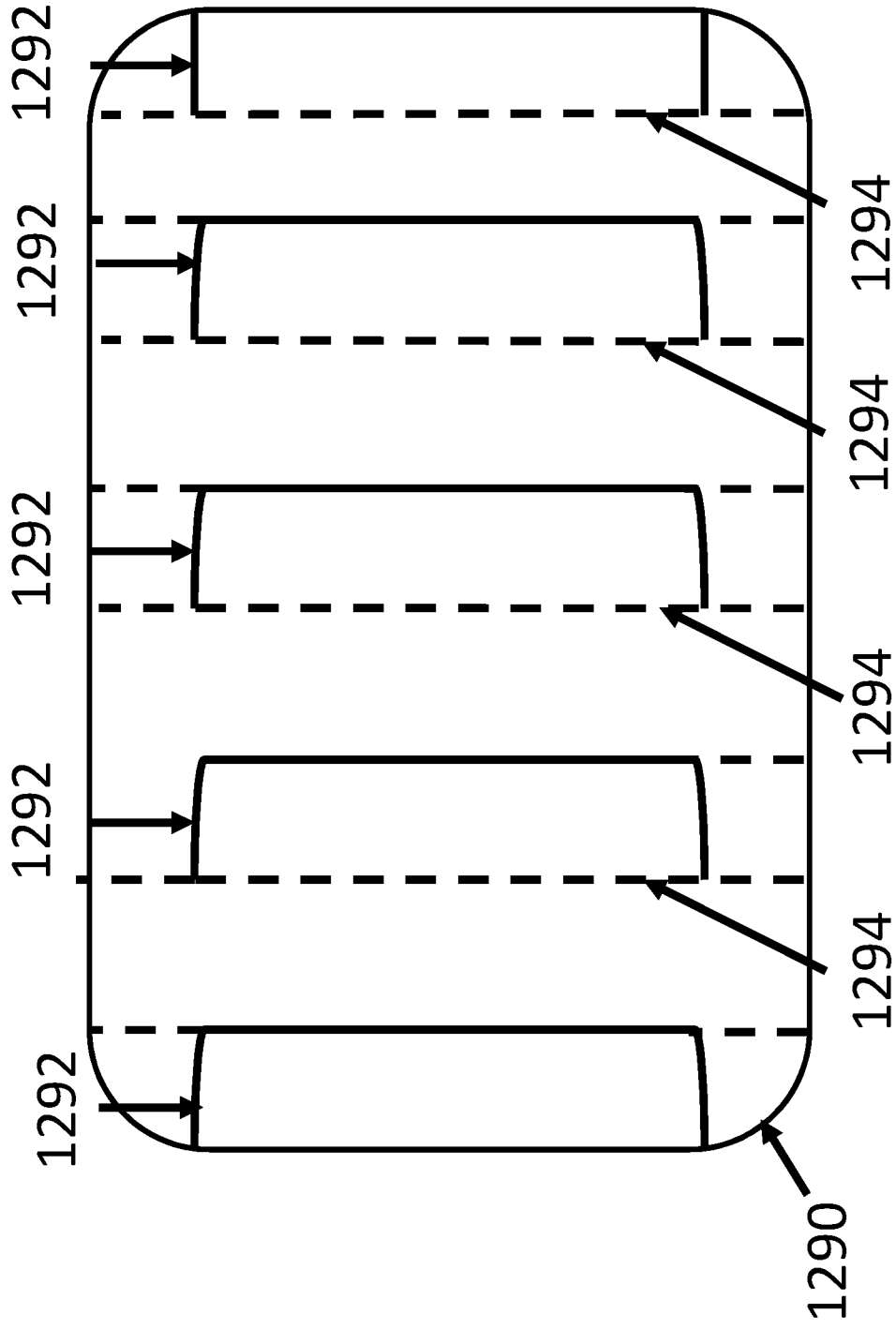

FIG 12A

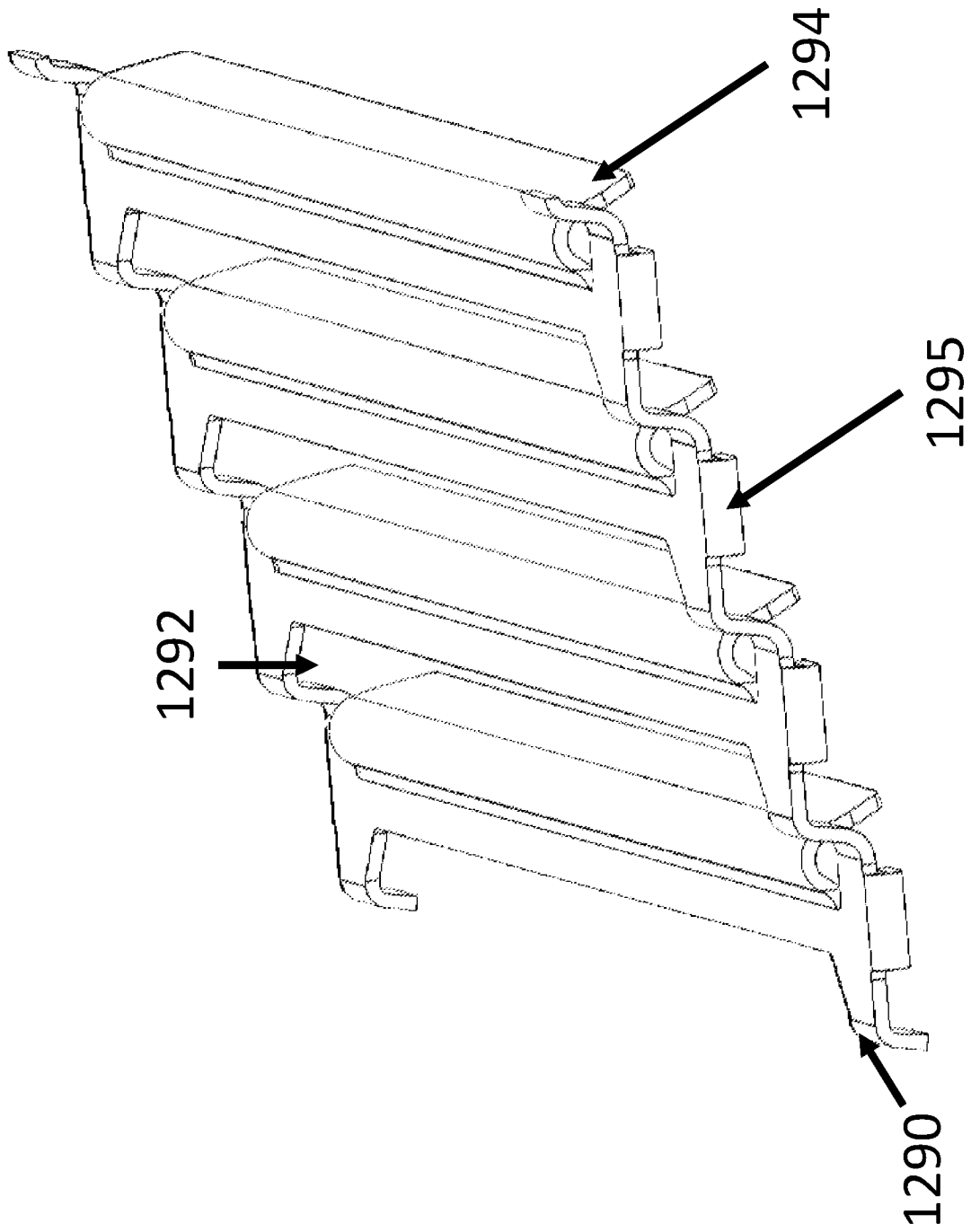

FIG 12B

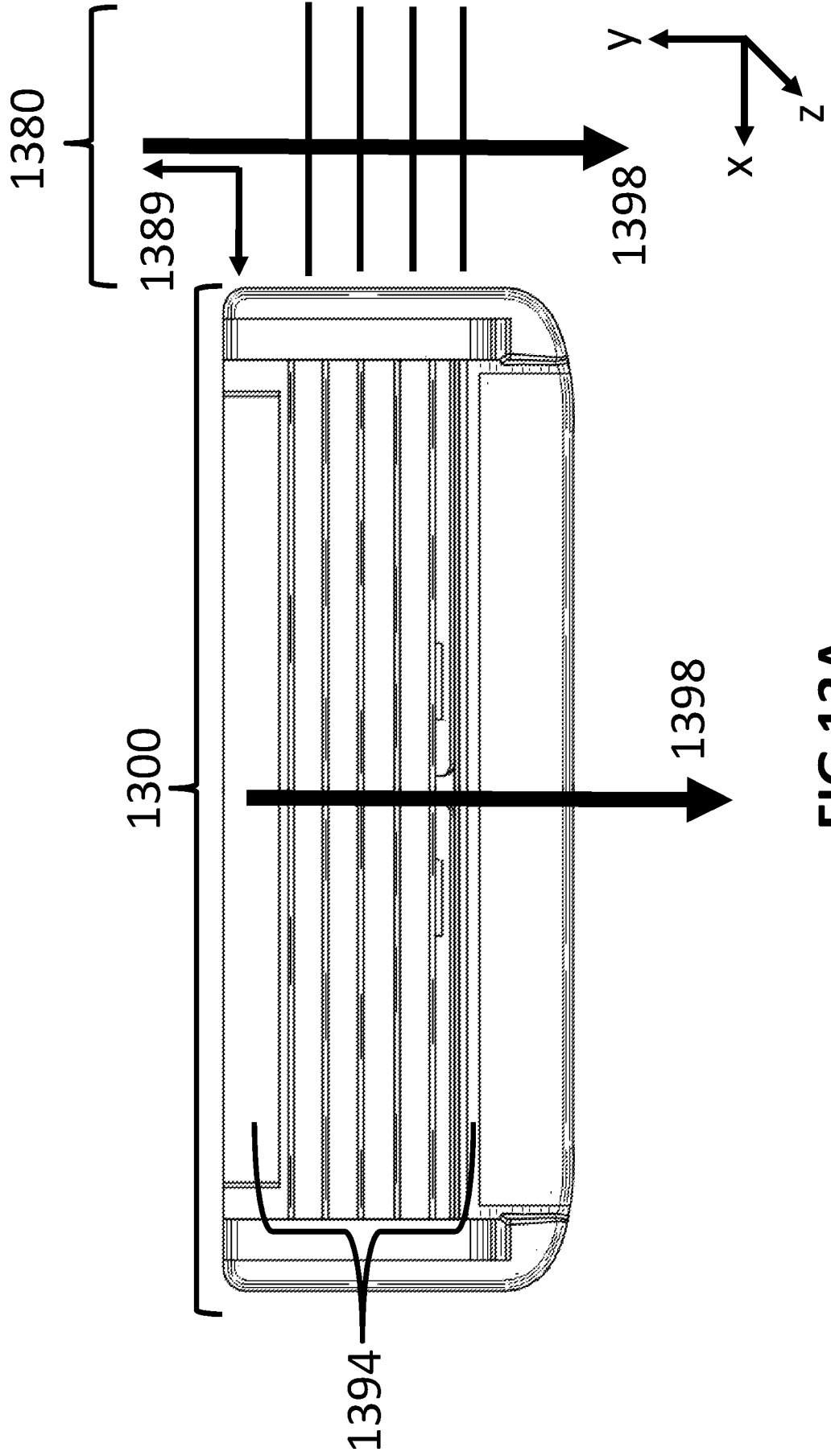

FIG 13A

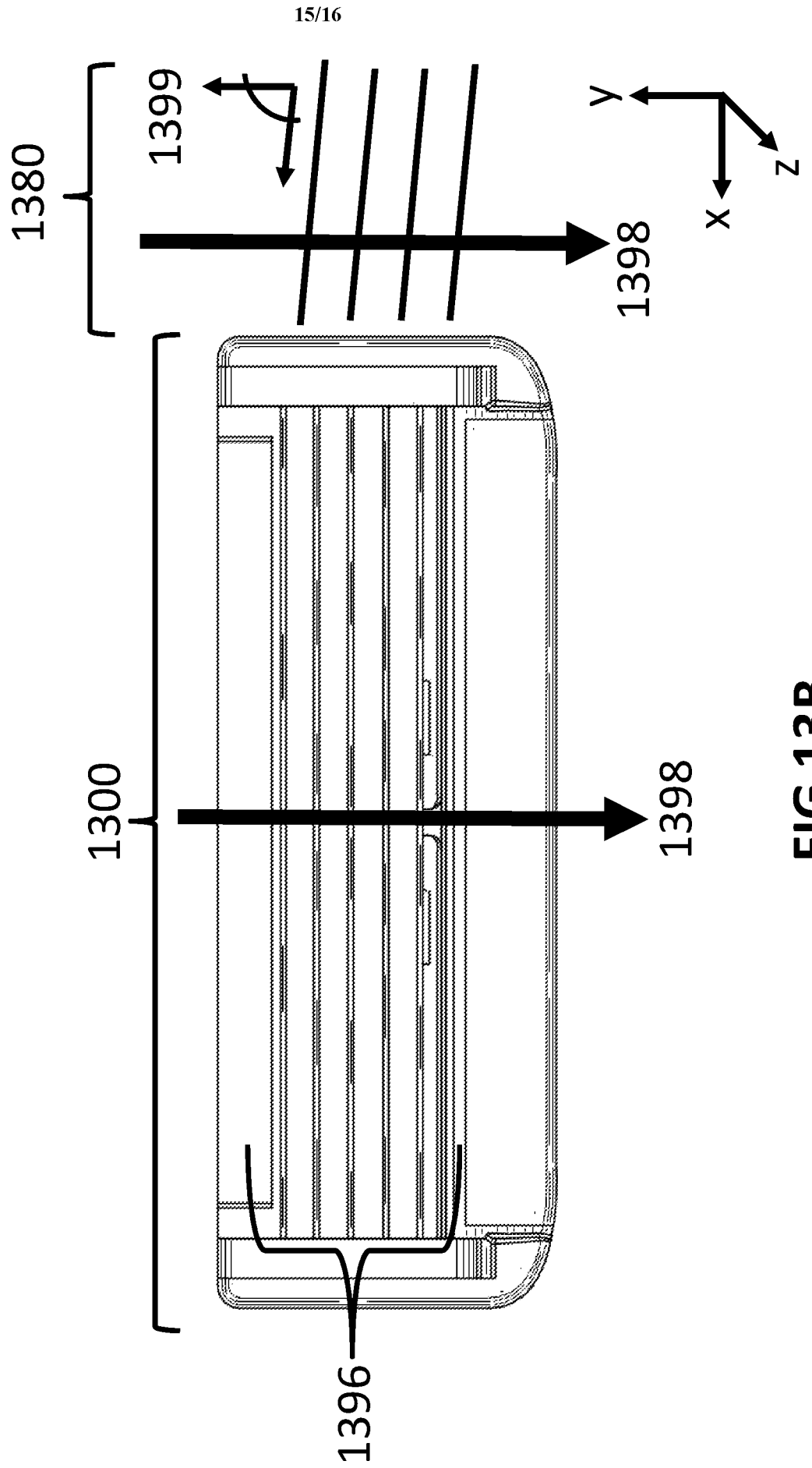

FIG 13B

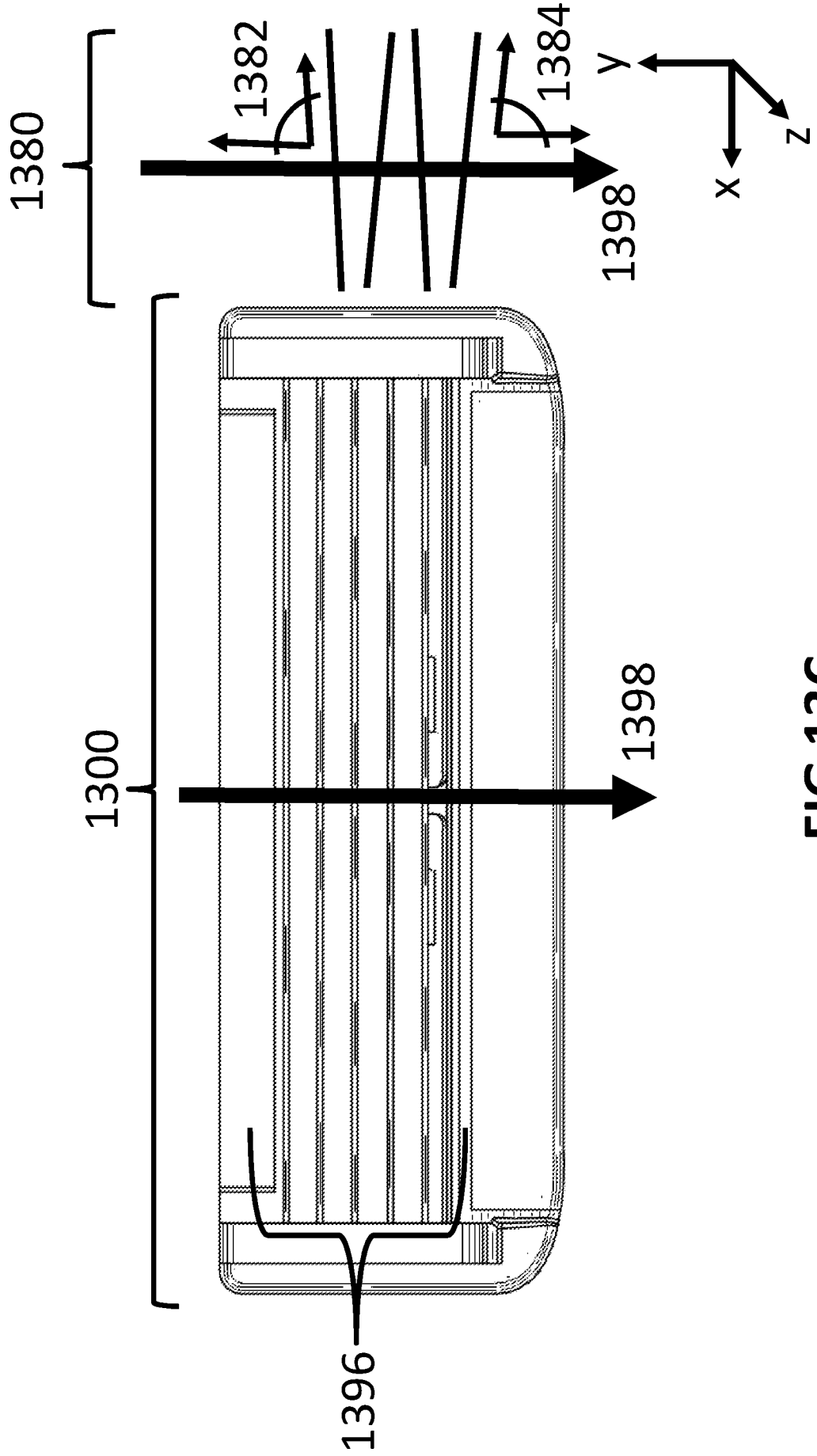

FIG 13C

INTERNATIONAL SEARCH REPORT

International application No.
PCT/US2017/023078

A. CLASSIFICATION OF SUBJECT MATTER
IPC(8) - B26B 21/22; B26B 21/14; B26B 21/20; B26B 21/40; B26B 21/54 (2017.01)
CPC - B26B 21/222; B26B 21/227; B26B 21/4018; B26B 21/4031; B26B 21/565 (2017.05)

According to International Patent Classification (IPC) or to both national classification and IPC

B. FIELDS SEARCHED

Minimum documentation searched (classification system followed by classification symbols)
See Search History document

Documentation searched other than minimum documentation to the extent that such documents are included in the fields searched
USPC - 30/34.2; 30/50; 30/51 (keyword delimited)

Electronic data base consulted during the international search (name of data base and, where practicable, search terms used)
See Search History document

C. DOCUMENTS CONSIDERED TO BE RELEVANT

Category*	Citation of document, with indication, where appropriate, of the relevant passages	Relevant to claim No.
X ---	US 2010/0154220 A1 (NAKASUKA) 24 June 2010 (24.06.2010) entire document	19 ---
Y		3, 7, 8, 14-17
Y	US 2004/0216310 A1 (SANTHAGENS VAN EIBERGEN et al) 04 November 2004 (04.11.2004) entire document	1-8, 11-17
Y	US 5,134,775 A (ALTHAUS et al) 04 August 1992 (04.08.1992) entire document	1-8, 11-13
Y	US 2014/0366381 A1 (PHIPPS et al) 18 December 2014 (18.12.2014) entire document	12, 13, 17
Y	WO 2016/040549 A1 (SHAVELOGIC, INC.) 17 March 2016 (17.03.2016) entire document	15
A	US 5,546,660 A (BUROUT et al) 20 August 1996 (20.08.1996) entire document	1-20
A	US 6,243,951 B1 (OLDROYD) 12 June 2001 (12.06.2001) entire document	1-20

Further documents are listed in the continuation of Box C. See patent family annex.

* Special categories of cited documents:	"T" later document published after the international filing date or priority date and not in conflict with the application but cited to understand the principle or theory underlying the invention
"A" document defining the general state of the art which is not considered to be of particular relevance	"X" document of particular relevance; the claimed invention cannot be considered novel or cannot be considered to involve an inventive step when the document is taken alone
"E" earlier application or patent but published on or after the international filing date	"Y" document of particular relevance; the claimed invention cannot be considered to involve an inventive step when the document is combined with one or more other such documents, such combination being obvious to a person skilled in the art
"L" document which may throw doubts on priority claim(s) or which is cited to establish the publication date of another citation or other special reason (as specified)	"&" document member of the same patent family
"O" document referring to an oral disclosure, use, exhibition or other means	
"P" document published prior to the international filing date but later than the priority date claimed	

Date of the actual completion of the international search 15 May 2017	Date of mailing of the international search report 22 MAY 2017
--	--

Name and mailing address of the ISA/US Mail Stop PCT, Attn: ISA/US, Commissioner for Patents P.O. Box 1450, Alexandria, VA 22313-1450 Facsimile No. 571-273-8300	Authorized officer Blaine R. Copenheaver PCT Helpdesk: 571-272-4300 PCT OSP: 571-272-7774
---	---