

(19) World Intellectual Property Organization
International Bureau



(43) International Publication Date
15 November 2007 (15.11.2007)

PCT

(10) International Publication Number
WO 2007/129953 A1

- (51) International Patent Classification:
G02B 6/44 (2006.01)
- (21) International Application Number:
PCT/SE2007/000429
- (22) International Filing Date: 4 May 2007 (04.05.2007)
- (25) Filing Language: Swedish
- (26) Publication Language: English
- (30) Priority Data:
0601060-7 10 May 2006 (10.05.2006) SE
- (71) Applicant (for all designated States except US): **MT SKELLEFTEÅ MEMOTEKNIK AB** [SE/SE]; Verkstadsvägen 1, S-931 61 Skellefteå (SE).
- (72) Inventors; and
- (75) Inventors/Applicants (for US only): **HEDSTRÖM, Lars** [SE/SE]; kanalgatan 27D, S-931 32 Skellefteå (SE). **NYSTRÖM, Kjell** [SE/SE]; Hjortrostigen 15, S-931 39 Skellefteå (SE). **LINDBERG, Robert** [SE/SE]; Daggstigen 10, S-931 51 Skellefteå (SE). **GRANKVIST, Stefan** [SE/SE]; Bockholmsvägen 4B, S-931 32 Skellefteå (SE).
- (74) Agents: **GRANSTRÖM, Lars-Eric** et al.; Zacco Sweden AB, P.O. Box 23101, S-104 35 Stockholm (SE).

- (81) Designated States (unless otherwise indicated, for every kind of national protection available): AE, AG, AL, AM, AT, AU, AZ, BA, BB, BG, BH, BR, BW, BY, BZ, CA, CH, CN, CO, CR, CU, CZ, DE, DK, DM, DZ, EC, EE, EG, ES, FI, GB, GD, GE, GH, GM, GT, HN, HR, HU, ID, IL, IN, IS, JP, KE, KG, KM, KN, KP, KR, KZ, LA, LC, LK, LR, LS, LT, LU, LY, MA, MD, MG, MK, MN, MW, MX, MY, MZ, NA, NG, NI, NO, NZ, OM, PG, PH, PL, PT, RO, RS, RU, SC, SD, SE, SG, SK, SL, SM, SV, SY, TJ, TM, TN, TR, TT, TZ, UA, UG, US, UZ, VC, VN, ZA, ZM, ZW.
- (84) Designated States (unless otherwise indicated, for every kind of regional protection available): ARIPO (BW, GH, GM, KE, LS, MW, MZ, NA, SD, SL, SZ, TZ, UG, ZM, ZW), Eurasian (AM, AZ, BY, KG, KZ, MD, RU, TJ, TM), European (AT, BE, BG, CH, CY, CZ, DE, DK, EE, ES, FI, FR, GB, GR, HU, IE, IS, IT, LT, LU, LV, MC, MT, NL, PL, PT, RO, SE, SI, SK, TR), OAPI (BF, BJ, CF, CG, CI, CM, GA, GN, GQ, GW, ML, MR, NE, SN, TD, TG).

Published:
 — with international search report
 — with amended claims

For two-letter codes and other abbreviations, refer to the "Guidance Notes on Codes and Abbreviations" appearing at the beginning of each regular issue of the PCT Gazette.

(54) Title: SPLICE HOLDER FOR OPTICAL FIBRES

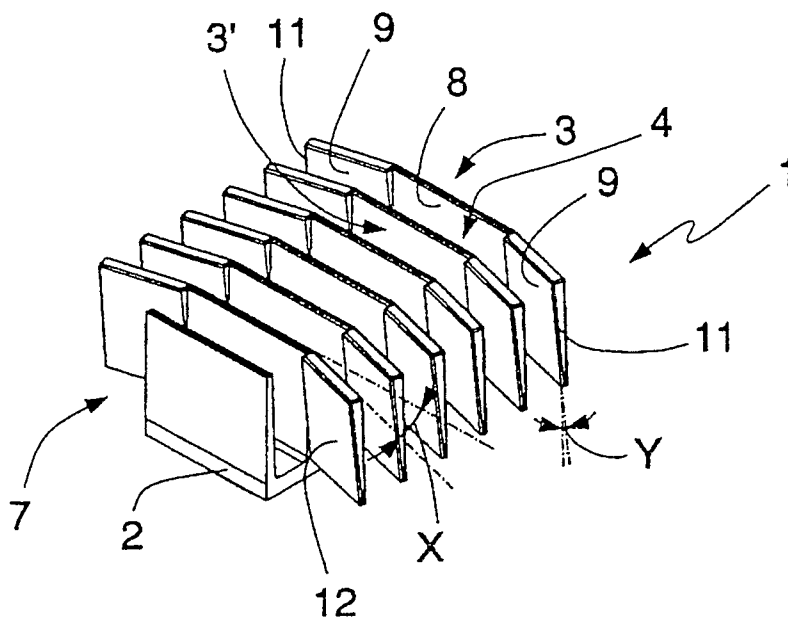

(57) Abstract: The invention concerns a splice holder (1) for optical fibres, comprising a plate-formed base (2) from one side of which a series of parallel walls (3, 3') extend that are arranged in a row after each other and situated at such a distance from each other that channels (4) for the reception of a splice sleeve (5) of a spliced optical fibre are limited between neighbouring walls in the row. In a splice holder that allows in a flexible manner established types of splice sleeves to be fixed in a manner that retains them, at least one wall (3) of such a defined channel (4) comprises a central wall section (8) extending from the base (2) and side sections of wall (9) extended in opposite directions from the central section of wall, which side sections are so designed that the splice sleeve (5) that is mounted in the channel is retained through a spring interaction between

the free edges (11) of the two side walls and the second wall (31) that limits the channel.

WO 2007/129953 A1

SPLICE HOLDER FOR OPTICAL FIBRES

The present invention concerns a splice holder intended to receive and support in a manner that retains in a fixed manner splices of optical fibres in a fibre-optical network.

5 A fibre cable normally comprises a bundle of several individual fibre-optical conductors, known as optical fibres. Each optical fibre comprises a doped glass core with a number of layers or shells that surround it. The said layers have the function of not only protecting the core, but also causing the light signal to be reflected internally in the optical fibre. Each individual optical fibre also has an outer layer or cover of plastic material that serves as protection and that makes it possible to colour-code the optical fibre. This plastic
10 cover must be peeled back or stripped off when the optical fibre is to be spliced.

A procedure known as "break-out" is carried out in special coupling stations in the form of cabinets or frames. This procedure is the division of incoming trunk fibre cables into the distribution network such that data traffic can be directed to each individual subscriber or workplace. The individual fibre-optical conductors have spliced onto them a contact in the
15 coupling station, in order to facilitate the movement or reconnection between different pieces of equipment or subscribers. The said splicing is normally carried out through the protective layer of the optical fibre being stripped off and the two ends of the fibres being welded together.

The optical fibres are thin and sensitive, and this means that the locations of splices
20 or points of connection between two fibre ends that have been connected in this manner must be carefully surrounded by protective splice sleeves that are similar to heat-shrink tubing, the thicknesses of which are to be considerably greater than that of the optical fibre. The splice sleeves after application not only extend over the stripped optical fibres: they also surround a part of the existing, non-stripped, plastic cover of the optical fibre. The splice
25 sleeves thus function to reduce the tensile load on the optical fibre. The splice sleeves are placed into specially designed holders, known as "splice holders", arranged on distribution trays arranged in the cabinet or frame mentioned above. The optical fibres are placed with a certain excess or slack in loops onto the distribution trays such that simple repairs to splices and similar can be carried out without needing to exchange the complete fibre cable.

30 The constructive designs of splice holders differ. It is normal that the splice sleeve has the form of a simple fibre splice, or of a ribbon of fibre splices. The splice sleeves may in certain cases have the form of a block, known as a "fan out" block.

Since the splice sleeve can demonstrate a number of different designs and thus also a number of different dimensions, it is necessary that the splice holders be flexibly designed
35 to such a degree that they can receive and support in an organised and secure manner the types of splice sleeve that are established without risk of damage to the optical fibres that have been joined in the splice sleeve.

One aim of the present invention is thus to achieve a splice holder with large flexibility that allows established types of splice sleeve to be mounted in the holder in a manner that retains them.

This aim of the invention is achieved through a splice holder demonstrating the
5 properties and characteristics that are specified in claim 1.

Other properties and advantages of the invention are made clear by subsequent claims and the description below of an embodiment, with reference to the attached drawings, in which Figure 1 shows a perspective view obliquely from above of the splice holder according to the invention, Figure 2 shows a perspective view of the splice holder obliquely
10 from below, Figure 3 shows a view equivalent to that in Figure 1 with a thinner first type of splice sleeve mounted in the splice holder, Figure 4 shows a view corresponding to that in Figure 1, but in this case with a thicker second type of splice sleeve mounted in the splice holder.

The splice holder for optical fibres shown in the figures and generally denoted by 1
15 has been manufactured in one piece of flexible material formed by injection moulding. The material that can be formed by injection moulding is constituted by a plastic material, preferably a thermoplastic such as polypropylene (PP) or polyvinyl chloride (PVC).

The splice holder 1 has a flat bottom 2 perpendicularly from one plane side of which a series of walls extend, generally denoted by reference numbers 3, 3' and parallel to each
20 other. The said walls 3, 3' have the form of lamellae arranged in a row after each other in the longitudinal direction of the base 2 and they are located at such a distance from each other that channels, generally denoted by reference number 4, are limited by neighbouring walls in the row. The channels 4 have been given such a width that one or several spliced optical fibres, which as a consequence of the splicing are provided with splice sleeves 5, can be
25 mounted in a very flexible manner and in a manner that allows fixing in the channels between the walls 3, 3'.

As is made clear by Figure 1, when viewed in a plan view or from above the walls 3, 3' are bent in planes that cut the base 2 perpendicularly. Each wall 3, 3' demonstrates a principally convex front 6 and a concave back 7. The wall 3, 3' that is in this way bent
30 consists of a centrally plane section of wall 8 extending from the base and side sections of wall 9 that extend from the said central section in opposite directions. The wall 3, 3' has been given the said bent shape in the direction of the splice sleeve 5 that is mounted in the channel 4 in order to offer the flexibility when receiving splice sleeves of different sizes that the invention strives to offer.

35 As is made most clear by Figures 1 and 2, the side sections of wall 9 extend in a freely supporting manner out from the central section of wall 8 and thus each one is elastically flexible relative to the central plane section of wall 8 along a single line. This line is

denoted by reference number 10 in Figure 2. The central plane section of wall 8 is thin-walled and it is arranged extending across the longitudinal direction of the base 2. The side sections of wall 9 are relatively easy to flex in a sideways direction along the lines 10 relative to the central section of wall 8, thus they are flexible around lines that are perpendicular to the principal plane of the base 2. The side sections of wall 9 can be regarded as plane, but they have been given an angled or wedge-shaped design that will be described in more detail below.

The two side sections of wall 9, that form a front wall 3 together with the central plane section of wall 8, are angled backwards at equal angles to the neighbouring rear second wall 3'. The side sections of wall 9 are angled backwards at an angle X relative to a plane parallel to the central section of wall 8. It is appropriate that this angle lies in the interval 10-20°, preferably 15°.

Figures 3 and 4 show a number of splice sleeves 5 mounted into the holder 1 according to the invention. The splice sleeves 5 in Figure 3 are of a first thinner design, while those in Figure 4 are of a somewhat broader second design 5'. The free edges 11 of the side sections of wall 9 are denoted by the reference number 11 in the drawings.

A closer study of the said drawings will reveal that the splice sleeves 5, 5' are mounted in the channels 4 in a retaining manner through a sprung interaction between free edges 11 of one front wall and the central wall section 8 of the limiting rear wall 3'.

Closer study of Figures 2 and 3 will reveal that the side sections of wall 9 have an oblique plane 12 and they become narrower, starting at an upper relatively broad upper section, equally in a wedge form downwards towards the region at the bottom of the receiving channels 4. As is made most clear by Figure 1, the side sections of wall 9 are considerably broader at the top than the central section of wall 8.

The plane 12 that becomes thinner has an angle Y that appropriately lies within the region 5-10°. It follows from this that the side wall sections 9 of one front wall 3 can be said to demonstrate double-angled surfaces to the rear second wall 3'. It should thus be understood that the splice sleeve 5 mounted in the channel 4 is forced down towards the bottom of the channel through the influence of the two wedge-shaped planes 12 of the side sections of wall 9, which planes are angled backwards and downwards. As a result of this, the retaining force for the splice sleeve 5 that has been mounted in the channels 4 will be a spring force and it will increase in tensile direction for the splice sleeve out from the channel.

As has been described in the introduction, the present splice holder 1 is intended to be mounted onto a distribution tray. Such a distribution tray is shown for simplicity's sake only as a fragmentary part in the drawings and it is denoted by the reference number 13. The splice holder 1 is provided with snap-on fastening means 14 in order to facilitate its mounting. As Figure 2 makes clear, the snap-on fastening means 14 are designed with hooks 15

having sharp edges that extend perpendicularly from the plane second side of the plate-shaped base 2. It is intended that the hooks 15 will interact for locking with holes 16 punched into the distribution tray whereby the hooks are caused through downwards driving to enter into locking interaction with the said holes.

5 The present invention is not limited to that described above and shown in the drawings: it can be changed and modified in a number of different ways within the framework of the innovative concept specified in the attached patent claims.

CLAIMS

1. A splice holder (1) for optical fibres, comprising a plate-formed base (2) from one side of which a series of parallel walls (3, 3') extend that are arranged in a row after each other and situated at such a distance from each other that channels (4) for the reception of a splice sleeve (5) of a spliced optical fibre are limited between neighbouring walls in the row, **characterised in** that at least one wall (3) of such a defined channel (4) comprises a central wall section (8) extending from the base (2) and side sections of wall (9) extending in opposite directions from the central section of wall, which side sections are so designed that the splice sleeve (5) that is mounted in the channel is retained through a spring interaction between the free edges (11) of the two side walls and the second wall (3') that limits the channel.

2. The splice holder according to claim 1, whereby the side sections of wall (9) for one wall (3) are angled backwards in a direction towards the neighbouring second wall (3').

3. The splice holder according to claim 2, whereby the side sections of wall (9) have been given such a form that the splice sleeve (5) that is mounted in the channel (4) is forced down towards the bottom of the channel.

4. The splice holder according to claim 3, whereby the side sections of wall (9) become thinner as wedges downwards towards the region at the bottom of the reception channel (4).

5. The splice holder according to claim 4, whereby the side sections of wall (9) have a thickness at the top that is greater than the thickness of the central section of wall (8).

6. The splice holder according to any one claims 1-5, whereby the walls (3, 3') are directed perpendicularly to the plate-formed base (2).

7. The splice holder according to any one claims 1-6, whereby walls (3, 3') that have both a central section of wall (8) and side sections of wall (9) are arranged in a series along the base (2) with equal distances between them.

8. The splice holder according to any one claims 1-7, comprising snap-on fastening means (14) designed to enter into locking interaction with holes in a distribution tray (13) that is arranged in a cabinet or on a frame for the support of not only loops of optical fibre cable but also splice holders.

9. The splice holder according to any one claims 1-8, manufactured as one piece of flexible injection-moulded plastic material of thermoplastic.

AMENDED CLAIMS**received by the International Bureau on 07 August 2007 (07.08.2007)**

1. A splice holder (1) for optical fibres, comprising a plate-formed base (2) from one side of which a series of parallel walls (3, 3') extend that are arranged in a row after each other and situated at such a distance from each other that channels (4) for the reception of a splice sleeve (5) of a spliced optical fibre are limited between neighbouring walls in the row, wherein at least one wall (3) of such a defined channel (4) comprises a central wall section (8) extending from the base (2) and side sections of wall (9) that are situated on both sides of the central section of wall, which side sections are so designed that the splice sleeve (5) that is mounted in the channel is retained through a spring interaction between the free edges (11) of the two side walls and the second wall (3') that limits the channel, **characterised in that the side sections of wall (9) have been given such a form that the splice sleeve (5) that is mounted in the channel (4) is forced down towards the bottom of the channel.**

2. The splice holder according to claim 1, whereby the side sections of wall (9) become thinner as wedges downwards towards the region at the bottom of the reception channel (4).

3. The splice holder according to claim 2, whereby the side sections of wall (9) have a thickness at the top that is greater than the thickness of the central section of wall (8).

4. The splice holder according to any one claims 1-3, whereby the walls (3, 3') are directed perpendicularly to the plate-formed base (2).

5. The splice holder according to any one claims 1-4, whereby walls (3, 3') that have both a central section of wall (8) and side sections of wall (9) are arranged in a series along the base (2) with equal distances between them.

6. The splice holder according to any one of claims 1-5, whereby the side sections of wall (9) for one wall (3) are angled backwards in a direction towards the neighbouring second wall (3').

7. The splice holder according to any one claims 1-6, the side sections of wall 9 extend in a freely supporting manner from both sides out from the central section of wall 8 and thus each one is elastically flexible relative to the central plane section of wall 8 along a single line (10) which is perpendicular to the principal plate-formed base (2).

8. The splice holder according to any one claims 1-7, comprising snap-on fastening means (14) designed to enter into locking interaction with holes in a distribution tray (13) that is arranged in a cabinet or on a frame for the support of not only loops of optical fibre cable but also splice holders.

5

9. The splice holder according to any one claims 1-8, manufactured as one piece of flexible injection-moulded plastic material of thermoplastic.

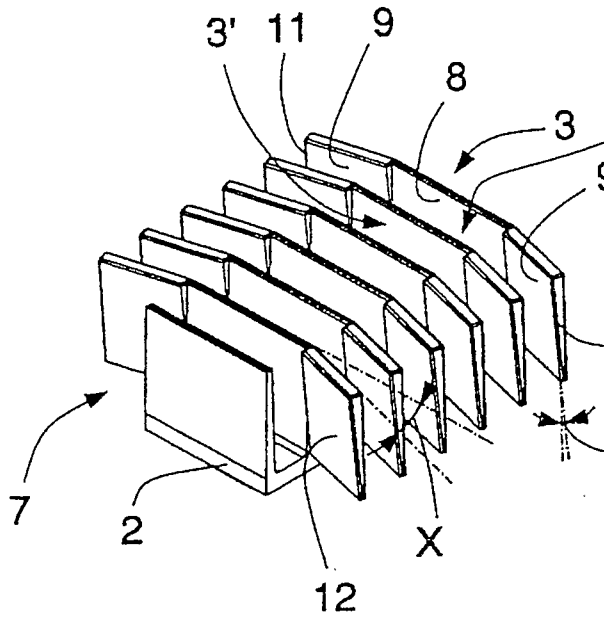

FIG. 1

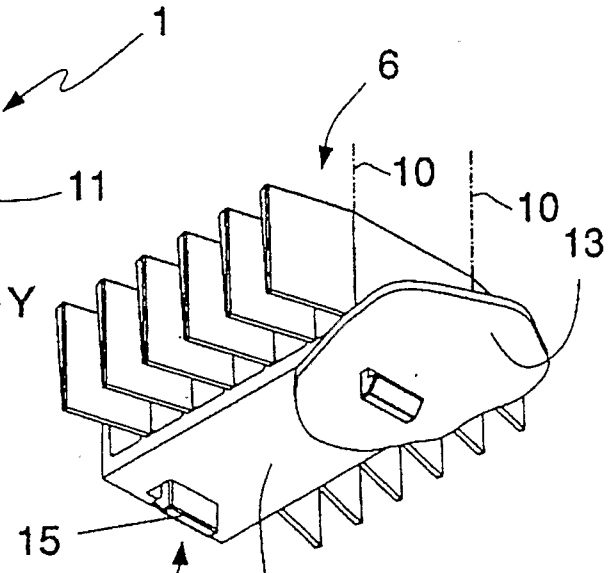

FIG. 2

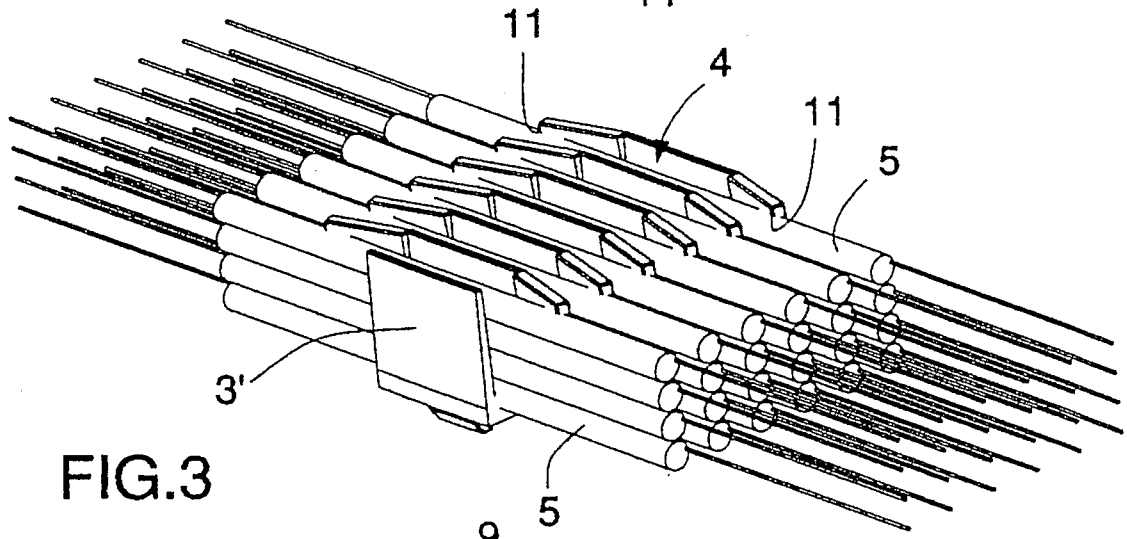

FIG. 3

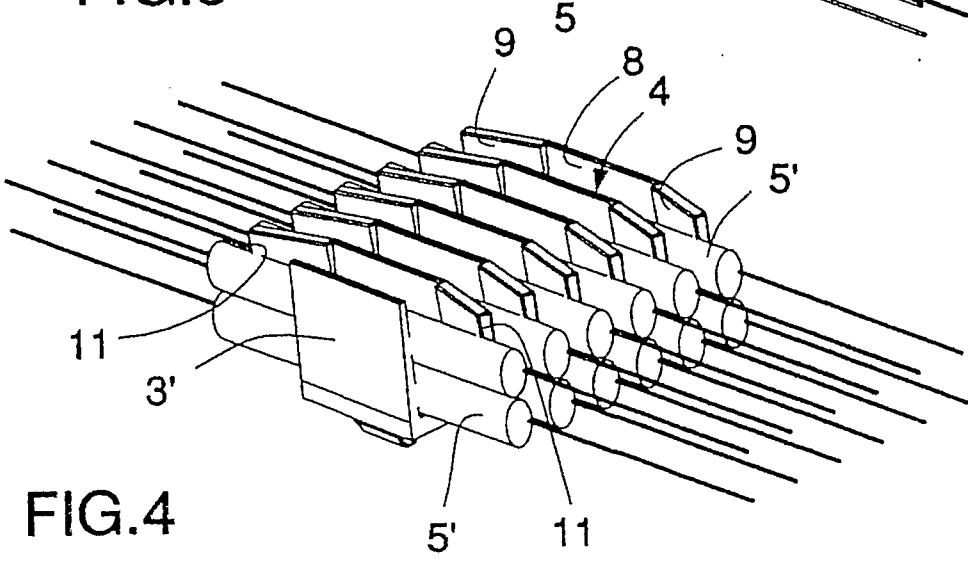

FIG. 4

INTERNATIONAL SEARCH REPORT

International application No.

PCT/SE2007/000429

A. CLASSIFICATION OF SUBJECT MATTER

IPC: see extra sheet

According to International Patent Classification (IPC) or to both national classification and IPC

B. FIELDS SEARCHED

Minimum documentation searched (classification system followed by classification symbols)

IPC: G02B

Documentation searched other than minimum documentation to the extent that such documents are included in the fields searched

SE,DK,FI,NO classes as above

Electronic data base consulted during the international search (name of data base and, where practicable, search terms used)

EPO-INTERNAL, WPI DATA, PAJ

C. DOCUMENTS CONSIDERED TO BE RELEVANT

Category*	Citation of document, with indication, where appropriate, of the relevant passages	Relevant to claim No.
X	GB 2254163 A (BICC PUBLIC LIMITED COMPANY), 30 Sept 1992 (30.09.1992), page 3, line 1 - line 13, abstract -- -----	1-9

 Further documents are listed in the continuation of Box C.
 See patent family annex.

* Special categories of cited documents:	"T" later document published after the international filing date or priority date and not in conflict with the application but cited to understand the principle or theory underlying the invention
"A" document defining the general state of the art which is not considered to be of particular relevance	"X" document of particular relevance: the claimed invention cannot be considered novel or cannot be considered to involve an inventive step when the document is taken alone
"E" earlier application or patent but published on or after the international filing date	"Y" document of particular relevance: the claimed invention cannot be considered to involve an inventive step when the document is combined with one or more other such documents, such combination being obvious to a person skilled in the art
"L" document which may throw doubts on priority claim(s) or which is cited to establish the publication date of another citation or other special reason (as specified)	"&" document member of the same patent family
"O" document referring to an oral disclosure, use, exhibition or other means	
"P" document published prior to the international filing date but later than the priority date claimed	

Date of the actual completion of the international search 30 July 2007	Date of mailing of the international search report 02 -08- 2007
---	--

Name and mailing address of the ISA/ Swedish Patent Office Box 5055, S-102 42 STOCKHOLM Facsimile No. +46 8 666 02 86	Authorized officer Magnus Westöö Telephone No. +46 8 782 25 00
--	--

INTERNATIONAL SEARCH REPORT

International application No.
PCT/SE2007/000429

International patent classification (IPC)

G02B 6/44 (2006.01)

Download your patent documents at www.prv.se

The cited patent documents can be downloaded at www.prv.se by following the links:

- In English/Searches and advisory services/Cited documents (service in English) or
- e-tjänster/anförda dokument (service in Swedish).

Use the application number as username.

The password is **RATOXAJWAG**.

Paper copies can be ordered at a cost of 50 SEK per copy from PRV InterPat (telephone number 08-782 28 85).

Cited literature, if any, will be enclosed in paper form.

INTERNATIONAL SEARCH REPORT
Information on patent family members

30/06/2007

International application No.
PCT/SE2007/000429

GB	2254163	A	30/09/1992	GB	9104958	D	00/00/0000
				GB	9204725	D	00/00/0000
				HK	35495	A	24/03/1995
				SG	16095	G	16/06/1995
