

(19) World Intellectual Property Organization
International Bureau



(43) International Publication Date
17 February 2005 (17.02.2005)

PCT

(10) International Publication Number
WO 2005/015100 A1

(51) International Patent Classification⁷: F25J 3/02

(21) International Application Number:
PCT/US2004/004072

(22) International Filing Date: 12 February 2004 (12.02.2004)

(25) Filing Language: English

(26) Publication Language: English

(30) Priority Data:
10/614,458 7 July 2003 (07.07.2003) US

(71) Applicant (for all designated States except US):
HOWE-BAKER ENGINEERS, LTD. [US/US]; 9800
Centre Parkway, Suite 700, Houston, TX 77036 (US).

(72) Inventors; and

(75) Inventors/Applicants (for US only): SCHROEDER,
Scott [US/US]; 10616 Meadowglen Lane, Apt. 2306,
Houston, TX 77042 (US). REDDICK, Kenneth [US/US];
915 West Main Street, Houston, TX 77006 (US).

(74) Agent: CARDEN, S., Richard; McDonnell Boehnen Hul-
bert & Berghoff, 300 South Wacker Drive, Chicago, IL
60606 (US).

(81) Designated States (unless otherwise indicated, for every
kind of national protection available): AE, AG, AL, AM,
AT, AU, AZ, BA, BB, BG, BR, BW, BY, BZ, CA, CH, CN,
CO, CR, CU, CZ, DE, DK, DM, DZ, EC, EE, EG, ES, FI,
GB, GD, GE, GH, GM, HR, HU, ID, IL, IN, IS, JP, KE,
KG, KP, KR, KZ, LC, LK, LR, LS, LT, LU, LV, MA, MD,
MG, MK, MN, MW, MX, MZ, NA, NI, NO, NZ, OM, PG,
PH, PL, PT, RO, RU, SC, SD, SE, SG, SK, SL, SY, TJ, TM,
TN, TR, TT, TZ, UA, UG, US, UZ, VC, VN, YU, ZA, ZM,
ZW.

(84) Designated States (unless otherwise indicated, for every
kind of regional protection available): ARIPO (BW, GH,
GM, KE, LS, MW, MZ, SD, SL, SZ, TZ, UG, ZM, ZW),
Eurasian (AM, AZ, BY, KG, KZ, MD, RU, TJ, TM), Euro-
pean (AT, BE, BG, CH, CY, CZ, DE, DK, EE, ES, FI, FR,
GB, GR, HU, IE, IT, LU, MC, NL, PT, RO, SE, SI, SK,
TR), OAPI (BF, BJ, CF, CG, CI, CM, GA, GN, GQ, GW,
ML, MR, NE, SN, TD, TG).

Published:
— with international search report

For two-letter codes and other abbreviations, refer to the "Guid-
ance Notes on Codes and Abbreviations" appearing at the begin-
ning of each regular issue of the PCT Gazette.

(54) Title: CRYOGENIC PROCESS FOR THE RECOVERY OF NATURAL GAS LIQUIDS FROM LIQUID NATURAL GAS

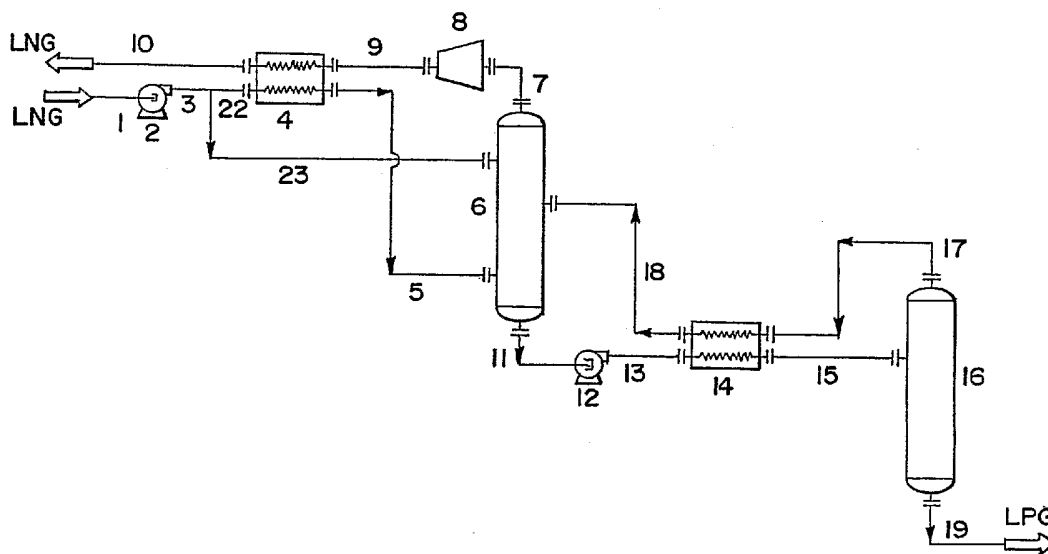

(57) Abstract: A process for the recovery of natural gas liquids (NGL) (ethane, ethylene, propane, propylene and heavier hydrocarbons) from liquefied natural gas (LNG) is disclosed. The LNG feed stream (1) is split (22,23) with at least one portion used as an external reflux (23), without prior treatment, to improve the separation and recovery of the natural gas liquids (NGL).

WO 2005/015100 A1

CRYOGENIC PROCESS FOR THE RECOVERY OF NATURAL GAS LIQUIDS
FROM LIQUID NATURAL GAS**FIELD OF THE INVENTION**

5 The present invention is directed toward the recovery of hydrocarbons heavier than methane from liquefied natural gas (LNG) and in particular to an improved process that provides for high-yield recovery of hydrocarbons heavier than methane while also producing a low BTU liquefied natural gas stream using minimal external heat supply.

10

BACKGROUND OF THE INVENTION

Natural gas typically contains up to 15 vol. % of hydrocarbons heavier than methane. Thus, natural gas is typically separated to provide a pipeline quality gaseous fraction and a less volatile liquid hydrocarbon fraction. These valuable natural gas liquids (NGL) are comprised of ethane, propane, butane, and minor amounts of other heavy hydrocarbons. In some circumstances, as an alternative to transportation in pipelines, natural gas at remote locations is liquefied and transported in special LNG tankers to appropriate LNG handling and storage terminals. The LNG can then be revaporized and used as a gaseous fuel in the same fashion as natural gas. Because the LNG is comprised of at least 80 mole percent methane it is often necessary to separate the methane from the heavier natural gas hydrocarbons to conform to pipeline specifications for heating value. In addition, it is desirable to recover the NGL because its components have a higher value as liquid products, where they are used as petrochemical feedstocks, compared to their value as fuel gas.

NGL is typically recovered from LNG streams by many well-known processes including "lean oil" adsorption, refrigerated "lean oil" absorption, and condensation at cryogenic temperatures. Although there are many known processes, there is always a compromise between high recovery and process simplicity (i.e., low capital investment). The most common process for recovering NGL from LNG is to pump and vaporize the LNG, and then redirect the resultant gaseous fluid to a typical industry standard turbo-expansion type cryogenic NGL recovery process. Such a process requires a large pressure drop across the turbo-expander or J.T. valve to generate cryogenic temperatures. In addition, such prior processes typically require that the resultant gaseous fluid, after LPG extraction, be compressed to attain the pre-expansion step pressure. Alternatives to this standard process are known and two such processes are disclosed in U.S. Pat. Nos. 5,588,308 and 5,114,451. The NGL recovery process described in the '308 patent uses autorefrigeration and integrated heat exchange instead of external refrigeration or feed turbo-expanders. This process, however, requires that the LNG feed be at ambient temperature and be pretreated to remove water, acid gases and other impurities. The process described in the '451 patent recovers NGL from a LNG feed that has been warmed by heat exchange with a compressed recycle portion of the fractionation overhead. The balance of the overhead, comprised of methane-rich residual gas, is compressed and heated for introduction into pipeline distribution systems.

Our invention provides another alternative NGL recovery process that produces a low-pressure, liquid methane-rich stream that can be directed to the main LNG export pumps where it can be pumped to pipeline pressures and eventually routed to the main LNG vaporizers. Moreover, our invention uses a

portion of the LNG feed directly as an external reflux in the separation process to achieve high yields of NGL as described in the specification below and defined in the claims which follow. Our invention also provides a sharp degree of separation between the desirable and undesirable components, thereby reducing overall fuel and energy consumption of the process.

SUMMARY OF THE INVENTION

As stated, our invention is directed to an improved process for the recovery of NGL from LNG, which avoids the need for dehydration, the removal of acid gases and other impurities. A further advantage of our process is that it significantly reduces the overall energy and fuel requirements because the residue gas compression requirements associated with a typical NGL recovery facility are virtually eliminated. Our process also does not require a large pressure drop across a turbo-expander or J.T. value to generate cryogenic temperatures. This reduces the capital investment to construct our process by 30 to 50% compared to a typical cryogenic NGL recovery facility.

Our invention also limits the heat gain of the LNG stream through the process, which in turn provides additional downstream benefits. By minimizing the heat gain of the LNG, we ensure that the LNG is completely liquefied prior to entering the high-pressure pipeline pumps and that no vapor is present at the suction of the pumps. The reduced heat gain also allows us to operate our process at lower throughputs than the plant capacity while still producing completely liquefied LNG upstream from the high pressure pipeline pumps. In addition, the inventive process allows us to flash the low BTU LNG stream into a storage tank while creating a minimal volume of vapor. The inventive process

also allows for the blending of boil-off vapor with the low BTU LNG, while still producing completely liquefied LNG upstream of the high pressure pumps.

In general, our process recovers hydrocarbons heavier than methane using low pressure liquefied natural gas (for example, directly from an LNG storage system) by using a recovery overhead from a deethanizer as a reflux stream to a recovery tower during the separation of a methane-rich stream from the heavier hydrocarbon liquids, thus producing high yields of NGL. In our invention the LNG feed stream to the recovery tower is heated to vaporize a portion of the stream, thereby minimizing the amount of fluid fed to the deethanizer, and the amount of external heating needed by the deethanizer, while also providing for high-yield recovery of the heavier hydrocarbons. The methane-rich overhead stream from the separation step is routed to the suction side of a low temperature, low head compressor to re-liquefy the stream. This re-liquefied LNG is then cross-heat exchanged with the feed stream and directed to main LNG export pumps. The liquid bottoms from the recovery tower are also partially vaporized by cross-exchange with the deethanizer overhead prior to being fed to the deethanizer to further limit the amount of external heat supply to the deethanizer.

In an alternate version of our invention, the methane-rich overhead from the recovery tower is cooled before being cross-exchanged with the feed stream. Possible variations of our process include rejecting the ethane while recovering the propane and heavier hydrocarbons, or similarly performing this split of any desired molecular weight hydrocarbon. In one of the possible variations of our process, propane recoveries are in the range of about 90 to 96% with 99+% butane-plus recovery.

In alternate versions of our invention, the overall recovery may be modified by providing reflux streams or additional feed streams to the recovery tower and/or the deethanizer. In one alternate version of our invention, the LNG feed stream to the recovery tower is split into a first split stream that is heated by cross-exchange with a compressed recovery tower overhead stream prior to being fed into the bottom of the recovery tower, and a second split stream that is fed directly into the top of the recovery tower. In a further alternate embodiment of our invention, the re-liquefied LNG stream is split into a first split stream that exits to the main LNG export pumps and a second split stream that is used as a reflux stream entering the top of the recovery tower. In yet a further alternate embodiment, the bottoms from the recovery tower is compressed and then split into a first split stream that is cross heat-exchanged with the overhead stream from the deethanizer prior to entering the deethanizer and a second split stream that is fed directly to the top of the deethanizer.

15

BRIEF DESCRIPTION OF THE DRAWINGS

FIG. 1 is a schematic flow diagram of the method of the present invention.

FIG. 2 is a schematic flow diagram of another method of the present invention.

20

FIG. 3 is a schematic flow diagram of yet another method of the present invention.

FIG. 4 is a schematic flow diagram of yet another method of the present invention.

FIG. 5 is a schematic flow diagram of yet another method of the present invention.

DETAILED DESCRIPTION OF THE INVENTION

Natural gas liquids (NGL) are recovered from low-pressure liquefied natural gas (LNG) without the need for external refrigeration or feed turboexpanders as used in prior processes. Referring to FIG. 1, process **100** shows the incoming LNG feed stream **1** enters pump **2** at very low pressures, typically in the range of 0-5 psig and at a temperature of less than -200°F. Pump **2** may be any pump design typically used for pumping LNG provided that it is capable of increasing the pressure of the LNG several hundred pounds to approximately 100-500 psig, preferably the process range of 300-350 psig. The resultant stream **3** from pump **2** is warmed and partially vaporized by cross-exchange in heat exchanger **4** with substantially NGL-free residue gas in stream **9** exiting the process **100**. After being warmed and partially vaporized, the resultant stream **5** from heat exchanger **4** is fed to recovery tower **6**. Recovery tower **6** may be comprised of a single separation process or a series flow arrangement of several unit operations routinely used to separate fractions of LNG feedstocks. The internal configuration of the particular recovery tower(s) used is a matter of routine engineering design and is not critical to our invention.

The overhead from recovery tower **6** is removed as a methane-rich stream **7** and is substantially free of NGL. The bottoms of recovery tower **6** is removed from process **100** through stream **11** and contains the recovered NGL product, which is further separated at a later point in the process to remove ethane. The methane-rich gas overhead in stream **7** is routed to the suction of a low temperature, low head compressor **8**. Compressor **8** is needed to provide

enough boost in pressure so that the exiting stream **9** maintains an adequate temperature difference in the main gas heat exchanger **4** to re-liquefy the methane-rich gas to form re-liquefied methane-rich (LNG) exit stream **10**. Compressor **8** is designed to achieve a marginal pressure increase of about 75 to
5 115 psi, preferably increasing the pressure from about 300 psig to about 350-425 psig. The re-liquefied LNG in stream **10** is directed to the main LNG export pumps (not shown) where the liquid will be pumped to pipeline pressures and eventually routed to the main LNG vaporizers.

The bottoms **11** from recovery tower **6** enters pump **12** at temperatures
10 ranging from -80 to -170°F and pressures ranging from 100 to 500 psia and the resulting pressurized stream **13** is fed to heat exchanger **14**, where it is heated to between -100 and 0°F . The resulting heated stream **15** is then fed to deethanizer **16**. Deethanizer **16** may be heated by a bottom reboiler or a side reboiler **27**, if needed. The overhead stream **17** from deethanizer **16** is passed
15 through heat exchanger **14** where it is used to heat the pressurized recovery tower bottoms stream **13**. The cooled deethanizer overhead stream **18** is used a reflux stream for recovery tower **6**. Hydrocarbons heavier than methane are removed from process **100** in the deethanizer bottoms stream **19**.

In the descriptions of Figures 2 to 5, equivalent stream and equipment
20 reference numbers are used to indicate identical equipment and stream compositions to those described previously in reference to FIG. 1.

As shown in Figure 2, in an alternative embodiment of the invention, stream **9** exiting compressor **8** is cooled in cooler **20** and the resultant pre-chilled

recovery tower overhead stream **21** is fed to heat exchanger **4**, where it is cross-heat exchanged with the pressurized feed stream **3**.

In alternate versions of our invention, the total recovery can be adjusted by providing reflux streams or additional feed streams to recovery tower **6** and/or
5 deethanizer **16**.

FIG. 3 illustrates an alternate embodiment of our invention where the pressurized feed stream **3** exiting pump **2** is split into a first and second split streams, **22** and **23** respectively. First split stream **22** is cross-heat exchanged with compressed recovery tower overhead stream **9** in heat exchanger **4** before
10 entering as a bottom feed stream **5** to recovery tower **6**. Second split stream **23** is fed directly to the top of recovery tower **6**.

As shown in FIG. 4, in a further alternate version of our invention, the compressed and re-liquefied overhead stream **10** from recovery tower **6** is split into first and second split streams, **24** and **25** respectively. First split stream **24**
15 exits process **100** directly to the main export pumps (not shown). Second split stream **25** is fed as a reflux stream directly to the top of recovery tower **6**.

FIG. 5 shows yet a further version of our invention, where the compressed bottoms stream **13** from recovery tower **6** is split into first and second split streams, **26** and **27** respectively. First split stream **26** is cross-heat exchanged
20 with the overhead stream **17** from deethanizer **16** in heat exchanger **14** and then fed to the top of deethanizer **16**. Second split stream **27** is fed directly to the top of deethanizer **16**.

The particular design of the heat exchangers, pumps, compressors and recovery towers is not critical to our invention; rather, it is a matter of routine
25 engineering practice to select and size the specific unit operations to achieve the

desired performance. Our invention lies with the unique combination of unit operations and the discovery of using untreated LNG as external reflux to achieve high levels of separation efficiency in order to recover NGL.

While we have described what we believe are the preferred embodiments
5 of the invention, those knowledgeable in this area of technology will recognize that other and further modifications may be made thereto, e.g., to adapt the invention to various conditions, type of feeds, or other requirements, without departing from the spirit of our invention as defined by the following claims.

We claim:

1. A process of recovering hydrocarbons heavier than methane from liquefied natural gas (LNG) comprising,
 - 5 a) pumping liquid, low pressure LNG to a pressure of greater than 100 psia;
 - b) splitting the pressurized liquid LNG from step a) into first and second portions;
 - 10 c) directing the first portion of pressurized liquid LNG from step b) to a cold box where it is heat exchanged to increase its temperature;
 - d) bypassing the cold box with the second portion of pressurized liquid LNG from step b) and directing it to a recovery tower as a first reflux;
 - e) directing the heat exchanged first portion of pressurized liquid LNG from
15 step c) to a recovery tower where, in combination with the first reflux and a second reflux, a recovery tower overhead is produced along with a recovery tower bottoms;
 - f) pressurizing the recovery tower bottoms and cross heat exchanging the pressurized recovery tower bottoms with deethanizer overhead;
 - 20 g) directing the cross heat exchanged pressurized recovery tower bottoms to a deethanizer;
 - h) removing hydrocarbons heavier than methane as deethanizer bottoms;
 - i) directing cross heat exchanged deethanizer overhead as the second reflux to the recovery tower; and
 - 25 j) removing the recovery tower overhead from the recovery tower and compressing the recovery tower overhead prior to introduction into the cold box and heat exchanging with the first portion of pressurized liquid LNG to produce a re-liquefied pressurized LNG.

2. The process of claim 1 further comprising the step of heating and recirculating the deethanizer bottoms stream.
- 5 3. The process of claim 1 further characterized in that a boil-off vapor is combined with the recovery tower overhead.
4. A process of recovering hydrocarbons heavier than methane from liquefied natural gas (LNG) comprising,
- 10 a) pumping liquid, low pressure LNG to a pressure of greater than 100 psia;
- b) directing the pressurized liquid LNG from step a) to a cold box where it is heat exchanged to increase its temperature;
- c) directing the heat exchanged pressurized liquid LNG from step b) to a
- 15 recovery tower where, in combination with a first and second reflux, a recovery tower overhead is produced along with a recovery tower bottoms;
- d) pressurizing the recovery tower bottoms and cross heat exchanging the pressurized recovery tower bottoms with deethanizer overhead;
- e) directing the cross heat exchanged pressurized recovery tower bottoms to
- 20 a deethanizer;
- f) removing hydrocarbons heavier than methane as deethanizer bottoms;
- g) directing cross heat exchanged deethanizer overhead as a second reflux to the recovery tower;
- h) removing the recovery tower overhead from the recovery tower and
- 25 compressing the recovery tower overhead prior to introduction into the cold box

and heat exchanging with the first portion of pressurized liquid LNG to produce a re-liquefied pressurized LNG; and

i) separating a portion of the re-liquefied pressurized LNG for use as the first reflux.

5

5. The process of claim 4 further comprising the step of heating and recirculating the deethanizer bottoms.

6. The process of claim 3 further characterized in that a boil-off vapor is combined with the recovery tower overhead.

10

7. A process of recovering hydrocarbons heavier than methane from liquefied natural gas (LNG) comprising,

a) pumping liquid, low pressure LNG to a pressure of greater than 100 psia;

15

b) directing the pressurized liquid LNG from step a) to a cold box where it is heat exchanged to increase its temperature;

c) directing the heat exchanged pressurized liquid LNG from step b) to a recovery tower where, in combination with a reflux, a recovery tower overhead is produced along with a recovery tower bottoms;

20

d) pressurizing the recovery tower bottoms and cross heat exchanging the pressurized recovery tower bottoms with deethanizer overhead;

e) directing the cross heat exchanged pressurized recovery tower bottoms to a deethanizer;

25

f) removing hydrocarbons heavier than methane as deethanizer bottoms;

g) directing cross heat exchanged deethanizer overhead as the flux to the recovery tower; and

h) removing the recovery tower overhead from the recovery tower and compressing the recovery tower overhead prior to introduction into the cold box and heat exchanging with the first portion of pressurized liquid LNG to produce a re-liquefied pressurized LNG.

5

8. The process of claim 7 further comprising the step of heating and recirculating the deethanizer bottoms.

9. The process of claim 5 further characterized in that a boil-off vapor is
10 combined with the recovery tower overhead.

10. The process of claim 5 further characterized in that the compressed recovery tower overhead is pre-chilled prior to introduction into the cold box.

15 11. A process of recovering hydrocarbons heavier than methane from liquefied natural gas (LNG) comprising,

a) pumping liquid, low pressure LNG to a pressure of greater than 100 psia;

b) directing the pressurized liquid LNG from step a) to a cold box where it is
20 heat exchanged to increase its temperature;

c) directing the heat exchanged pressurized liquid LNG from step b) to a recovery tower where, in combination with a reflux, a recovery tower overhead is produced along with a recovery tower bottoms;

d) pressurizing the recovery tower bottoms

25 e) separating the pressurized recovery bottoms into a first and second portion

- f) cross heat exchanging the first portion of pressurized recovery tower bottoms with deethanizer overhead and directing the cross heat exchanged pressurized recovery tower bottoms to a deethanizer;
 - g) directing the second portion of pressurized recovery tower bottoms without
5 heat exchanging to the deethanizer as reflux;
 - h) removing hydrocarbons heavier than methane as deethanizer bottoms;
 - i) directing cross heat exchanged deethanizer overhead as the flux to the recovery tower; and
 - j) removing the recovery tower overhead from the recovery tower and
10 compressing the recovery tower overhead prior to introduction into the cold box and heat exchanging with the first portion of pressurized liquid LNG to produce a re-liquefied pressurized LNG.
12. The process of claim 11 further comprising heating and recirculating the
15 deethanizer bottoms.
13. The process of claim 8 further characterized in that a boil-off vapor is combined with the recovery tower overhead.

FIG. 1

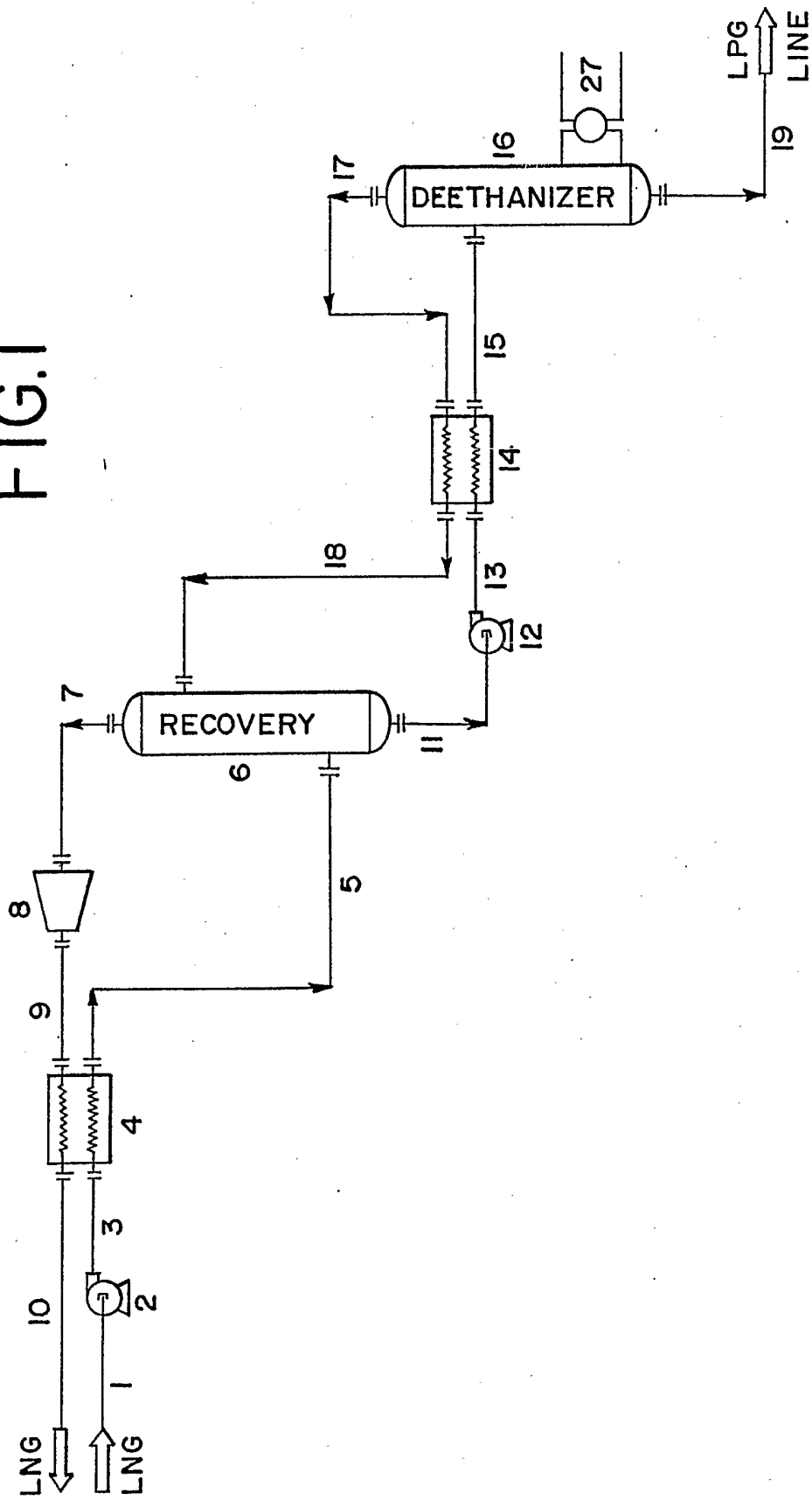
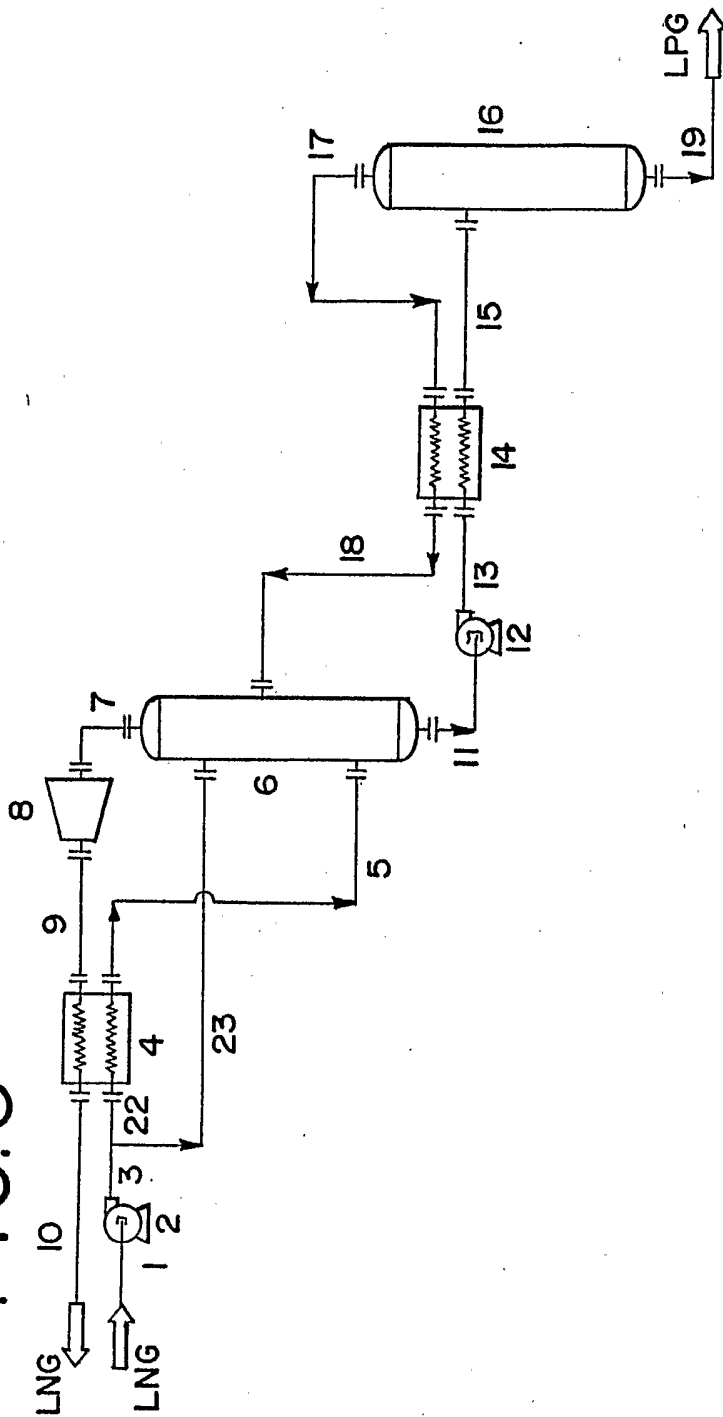

FIG. 3



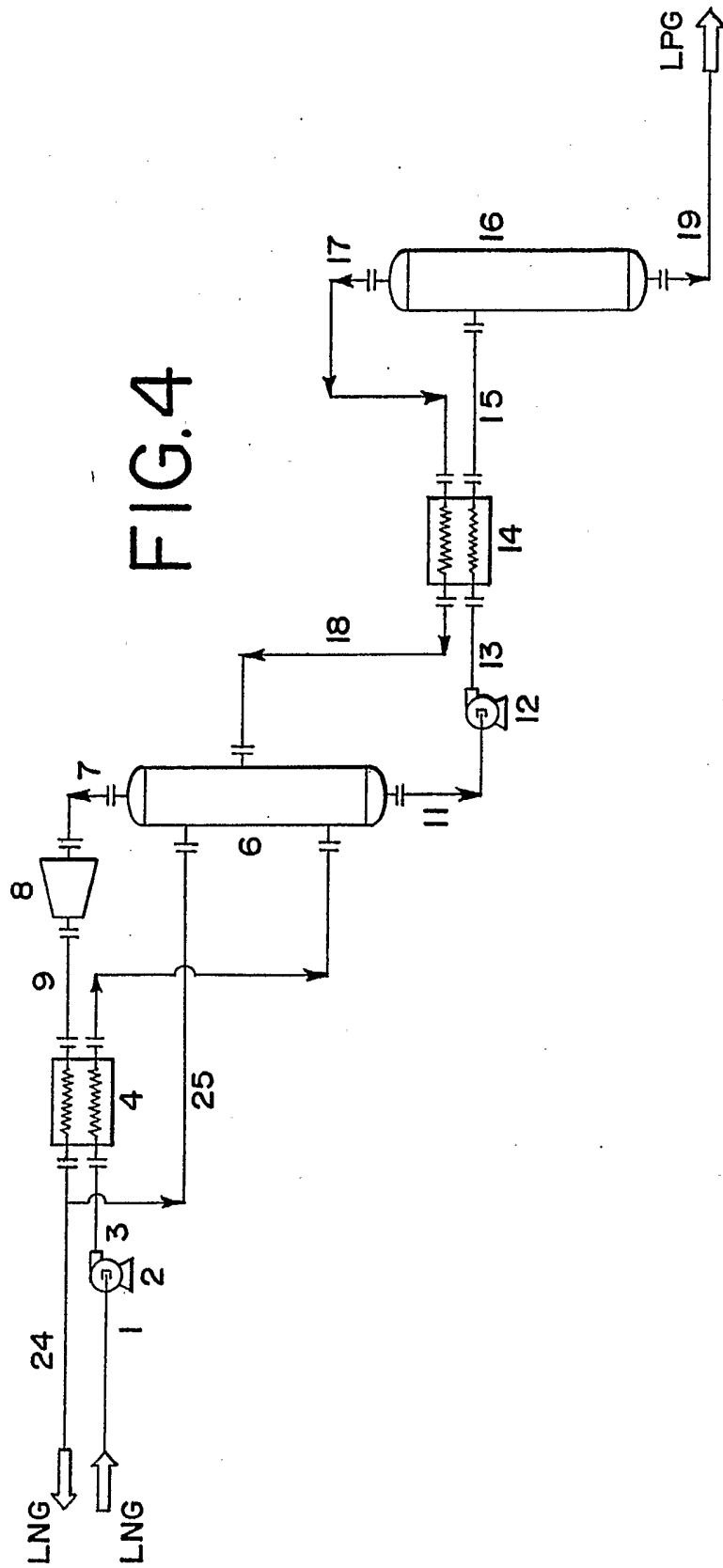
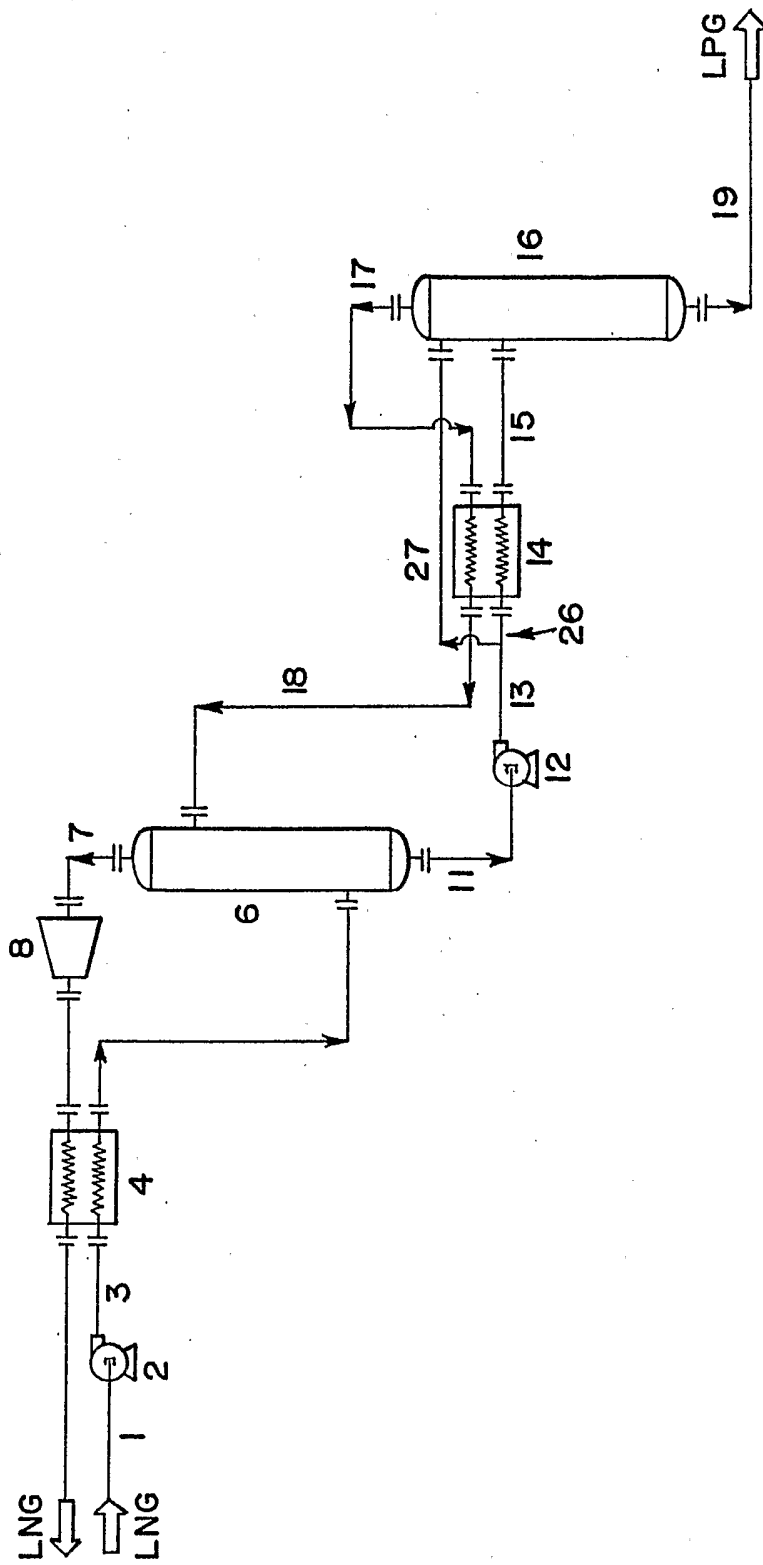

FIG.5



INTERNATIONAL SEARCH REPORT

International Application No.
PCT/US2004/004072

A. CLASSIFICATION OF SUBJECT MATTER
IPC 7 F25J3/02

According to International Patent Classification (IPC) or to both national classification and IPC

B. FIELDS SEARCHED

Minimum documentation searched (classification system followed by classification symbols)
IPC 7 F25J

Documentation searched other than minimum documentation to the extent that such documents are included in the fields searched

Electronic data base consulted during the international search (name of data base and, where practical, search terms used)

EPO-Internal

C. DOCUMENTS CONSIDERED TO BE RELEVANT

Category °	Citation of document, with indication, where appropriate, of the relevant passages	Relevant to claim No.
Y	US 6 564 579 B1 (MCCARTNEY DANIEL G) 20 May 2003 (2003-05-20) figure 2	1-3
Y	----- US 4 689 063 A (CASTEL JOELLE ET AL) 25 August 1987 (1987-08-25) figures 1,2	1-3
A	----- US 2002/029585 A1 (WINNINGHAM HORACE G ET AL) 14 March 2002 (2002-03-14) paragraph [0012]; figure	1,2
A	----- US 3 405 530 A (DENAHAN RICHARD A ET AL) 15 October 1968 (1968-10-15) column 2, line 62 - line 64; figure	1,2
A	----- US 3 837 821 A (GRENIER M ET AL) 24 September 1974 (1974-09-24) column 3, line 46 - line 54; figure 1	3

Further documents are listed in the continuation of box C.

Patent family members are listed in annex.

° Special categories of cited documents :

- "A" document defining the general state of the art which is not considered to be of particular relevance
- "E" earlier document but published on or after the international filing date
- "L" document which may throw doubts on priority claim(s) or which is cited to establish the publication date of another citation or other special reason (as specified)
- "O" document referring to an oral disclosure, use, exhibition or other means
- "P" document published prior to the international filing date but later than the priority date claimed

- "T" later document published after the international filing date or priority date and not in conflict with the application but cited to understand the principle or theory underlying the invention
- "X" document of particular relevance; the claimed invention cannot be considered novel or cannot be considered to involve an inventive step when the document is taken alone
- "Y" document of particular relevance; the claimed invention cannot be considered to involve an inventive step when the document is combined with one or more other such documents, such combination being obvious to a person skilled in the art.
- "&" document member of the same patent family

Date of the actual completion of the international search

8 June 2004

Date of mailing of the international search report

15. 09. 2004

Name and mailing address of the ISA
European Patent Office, P.B. 5818 Patentlaan 2
NL - 2280 HV Rijswijk
Tel. (+31-70) 340-2040, Tx. 31 651 epo nl,
Fax: (+31-70) 340-3016

Authorized officer

Göritz, D

INTERNATIONAL SEARCH REPORT

International application No.
PCT/US2004/004072

Box II Observations where certain claims were found unsearchable (Continuation of item 2 of first sheet)

This International Search Report has not been established in respect of certain claims under Article 17(2)(a) for the following reasons:

- 1. Claims Nos.:
because they relate to subject matter not required to be searched by this Authority, namely:

- 2. Claims Nos.:
because they relate to parts of the International Application that do not comply with the prescribed requirements to such an extent that no meaningful International Search can be carried out, specifically:

- 3. Claims Nos.:
because they are dependent claims and are not drafted in accordance with the second and third sentences of Rule 6.4(a).

Box III Observations where unity of invention is lacking (Continuation of item 3 of first sheet)

This International Searching Authority found multiple inventions in this international application, as follows:

see additional sheet

- 1. As all required additional search fees were timely paid by the applicant, this International Search Report covers all searchable claims.

- 2. As all searchable claims could be searched without effort justifying an additional fee, this Authority did not invite payment of any additional fee.

- 3. As only some of the required additional search fees were timely paid by the applicant, this International Search Report covers only those claims for which fees were paid, specifically claims Nos.:

- 4. No required additional search fees were timely paid by the applicant. Consequently, this International Search Report is restricted to the invention first mentioned in the claims; it is covered by claims Nos.:

1-3

Remark on Protest

- The additional search fees were accompanied by the applicant's protest.
- No protest accompanied the payment of additional search fees.

FURTHER INFORMATION CONTINUED FROM PCT/ISA/ 210

~~This International Searching Authority found multiple (groups of) inventions in this international application, as follows:~~

1. claims: 1,2,3

A process of recovering hydrocarbons heavier than CH₄ from LNG wherein the pressurized LNG feed is split with at least one portion used as an external reflux in a recovery tower without prior treatment, the tower bottoms is heated against the de-ethanizer overhead and fed to the de-ethanizer, the de-ethanizer overhead after cooling is fed as a second reflux to the tower and wherein the tower overhead is cold compressed and liquefied against the pressurized LNG feed.

2. claims: 4,5,6

A process of recovering hydrocarbons heavier than CH₄ from LNG wherein the pressurized LNG after heating is fed to a recovery tower, the tower bottoms is heated against the de-ethanizer overhead and fed to the de-ethanizer, the de-ethanizer overhead after cooling is fed as a first reflux to the tower and wherein the tower overhead is cold compressed and liquefied against the pressurized LNG feed with at least one portion used as a second reflux in the recovery tower.

3. claims: 7-10

A process of recovering hydrocarbons heavier than CH₄ from LNG wherein the pressurized LNG is fed to a recovery tower, the tower bottoms is heated against the de-ethanizer overhead and fed to the de-ethanizer, the de-ethanizer overhead after cooling is fed as a reflux to the tower and wherein the tower overhead is cold compressed and liquefied against the pressurized LNG feed.

4. claims: 11-13

A process of recovering hydrocarbons heavier than CH₄ from LNG wherein the pressurized LNG feed is fed to a recovery tower, the tower bottoms is split into a first and second portion, the first portion is heated against the de-ethanizer overhead and fed to the de-ethanizer, the second portion is fed to the de-ethanizer as a reflux without heating, the de-ethanizer overhead after cooling is fed as a reflux to the tower and wherein the tower overhead is cold compressed and liquefied against the pressurized LNG feed.

INTERNATIONAL SEARCH REPORT
Information on patent family members

International Application No.
PCT/US2004/004072

Patent document cited in search report	Publication date	Patent family member(s)	Publication date
US 6564579	B1	20-05-2003 WO 03095914 A1	20-11-2003
US 4689063	A	25-08-1987 FR 2578637 A1	12-09-1986
		DE 3660322 D1	21-07-1988
		EP 0197808 A1	15-10-1986
US 2002029585	A1	14-03-2002 AU 7501601 A	11-12-2001
		TW 555582 B	01-10-2003
		WO 0192778 A1	06-12-2001
US 3405530	A	15-10-1968 NONE	
US 3837821	A	24-09-1974 NONE	