

(12) INTERNATIONAL APPLICATION PUBLISHED UNDER THE PATENT COOPERATION TREATY (PCT)

(19) World Intellectual Property
Organization
International Bureau



(10) International Publication Number
WO 2014/133406 A1

(43) International Publication Date
4 September 2014 (04.09.2014)

(51) International Patent Classification:

F23C 9/00 (2006.01) F23R 3/36 (2006.01)
F23R 3/28 (2006.01)

(21) International Application Number:

PCT/RU2013/000162

(22) International Filing Date:

28 February 2013 (28.02.2013)

(25) Filing Language:

English

(26) Publication Language:

English

(71) Applicants: GENERAL ELECTRIC COMPANY [US/US]; 1 River Road, Schenectady, New York, 12345 (US). EXXONMOBIL UPSTREAM RESEARCH COMPANY [US/US]; P.O. Box 2189, Houston, TX 77252-2189 (US).

(72) Inventors: GINESIN, Leonid Yul'evich; Tarasa Shevchenko naberezhnaya, Bld. 1/2, Apt. 264, Moscow, 121059 (RU). SHERSHNYOV, Borys Borysovich; Brateevskaya str., 21, building 3, apartment 47, Moscow, 115612 (RU). SIDKO, Igor Petrovich; str. Verhnie polya, 35/5, Apart. 29, Moscow, 109559 (RU). VALEEV, Almaz Kamilevich; Demyana Bednogo Str., 20, bld. 3, app. 29, Moscow, 123308 (RU). MESHKOV, Sergey Anatolievich; Novinki street, bld.9, app.31, 115470 Moscow (RU).

(74) Agent: LAW FIRM "GORODISSKY AND PARTNERS" LTD.; MITS Alexander Vladimirovich, POPOVA

Elizaveta Vitalievna, Bolshaya Spasskaya str., 25, bldg. 3, Moscow, 129090 (RU).

(81) Designated States (unless otherwise indicated, for every kind of national protection available): AE, AG, AL, AM, AO, AT, AU, AZ, BA, BB, BG, BH, BN, BR, BW, BY, BZ, CA, CH, CL, CN, CO, CR, CU, CZ, DE, DK, DM, DO, DZ, EC, EE, EG, ES, FI, GB, GD, GE, GH, GM, GT, HN, HR, HU, ID, IL, IN, IS, JP, KE, KG, KM, KN, KP, KR, KZ, LA, LC, LK, LR, LS, LT, LU, LY, MA, MD, ME, MG, MK, MN, MW, MX, MY, MZ, NA, NG, NI, NO, NZ, OM, PA, PE, PG, PH, PL, PT, QA, RO, RS, RU, RW, SC, SD, SE, SG, SK, SL, SM, ST, SV, SY, TH, TJ, TM, TN, TR, TT, TZ, UA, UG, US, UZ, VC, VN, ZA, ZM, ZW.

(84) Designated States (unless otherwise indicated, for every kind of regional protection available): ARIPO (BW, GH, GM, KE, LR, LS, MW, MZ, NA, RW, SD, SL, SZ, TZ, UG, ZM, ZW), Eurasian (AM, AZ, BY, KG, KZ, RU, TJ, TM), European (AL, AT, BE, BG, CH, CY, CZ, DE, DK, EE, ES, FI, FR, GB, GR, HR, HU, IE, IS, IT, LT, LU, LV, MC, MK, MT, NL, NO, PL, PT, RO, RS, SE, SI, SK, SM, TR), OAPI (BF, BJ, CF, CG, CI, CM, GA, GN, GQ, GW, ML, MR, NE, SN, TD, TG).

Published:

— with international search report (Art. 21(3))

(54) Title: SYSTEM AND METHOD FOR A TURBINE COMBUSTOR

(57) Abstract: A system includes a turbine combustor, which includes a head end portion having a head end chamber. The head end portion includes an exhaust gas path, a fuel path, and an oxidant path. The turbine combustor also includes a combustion portion having a combustion chamber disposed downstream from the head end chamber, a cap disposed between the head end chamber and the combustion chamber, and an end plate having at least one port coupled to the exhaust gas path or the oxidant path. The head end chamber is disposed axially between the cap and the end plate.



WO 2014/133406 A1

SYSTEM AND METHOD FOR A TURBINE COMBUSTOR

BACKGROUND OF THE INVENTION

The subject matter disclosed herein relates to gas turbine engines, and more particularly, to systems and methods for turbine combustors of gas turbine engines.

5 Gas turbine engines are used in a wide variety of applications, such as power generation, aircraft, and various machinery. Gas turbine engines generally combust a fuel with an oxidant (e.g., air) in a combustor section to generate hot combustion products, which then drive one or more turbine stages of a turbine section. In turn, the turbine section drives one or more compressor stages of a compressor section, thereby
10 compressing oxidant for intake into the combustor section along with the fuel. Again, the fuel and oxidant mix in the combustor section, and then combust to produce the hot combustion products. Gas turbine engines generally premix the fuel and oxidant along one or more flow paths upstream from a combustion chamber of the combustor section. Unfortunately, certain components of the combustor section are exposed to
15 high temperatures, which may reduce the life of the components. Furthermore, gas turbine engines typically consume a vast amount of air as the oxidant, and output a considerable amount of exhaust gas into the atmosphere. In other words, the exhaust gas is typically wasted as a byproduct of the gas turbine operation.

BRIEF DESCRIPTION OF THE INVENTION

20 Certain embodiments commensurate in scope with the originally claimed invention are summarized below. These embodiments are not intended to limit the scope of the claimed invention, but rather these embodiments are intended only to provide a brief summary of possible forms of the invention. Indeed, the invention may encompass a variety of forms that may be similar to or different from the embodiments
25 set forth below.

In a first embodiment, a system includes a turbine combustor, which includes a head end portion having a head end chamber. The head end portion includes an exhaust gas path, a fuel path, and an oxidant path. The turbine combustor also includes a combustion portion having a combustion chamber disposed downstream from the head
30 end chamber, a cap disposed between the head end chamber and the combustion chamber, and an end plate having at least one port coupled to the exhaust gas path or the oxidant path. The head end chamber is disposed axially between the cap and the

end plate.

In a second embodiment, a system includes a turbine combustor, which includes a head end portion having a head end chamber. The head end portion includes an exhaust gas path, a fuel path, and an oxidant path. The turbine combustor also includes combustion portion having a combustion chamber disposed downstream from the head end chamber, a cap disposed between the head end chamber and the combustion chamber, and an end plate having a first oxidant inlet of the oxidant path. The head end chamber is disposed axially between the cap and the end plate.

In a third embodiment, a system includes a turbine combustor, which includes a head end portion having a head end chamber. The head end portion includes an exhaust gas path, a fuel path, and an oxidant path. The turbine combustor also includes a combustion portion having a combustion chamber disposed downstream from the head end chamber, a cap disposed between the head end chamber and the combustion chamber, and an end plate having a first exhaust outlet of the exhaust gas path. The head end chamber is disposed axially between the cap and the end plate.

In a fourth embodiment, a system includes a turbine combustor, which includes a head end portion having a head end chamber. The head end portion includes an exhaust gas path, a fuel path, and an oxidant path. The turbine combustor also includes a combustion portion having a combustion chamber disposed downstream from the head end chamber, a cap disposed between the head end chamber and the combustion chamber, and an end plate. The head end chamber is disposed axially between the cap and the end plate. The turbine combustor also includes a fuel manifold disposed between the cap and the end plate. The fuel manifold includes a first radial fuel inlet coupled to a first fuel path of the fuel path and the first fuel path includes a first radial path and a first circumferential path disposed about a centerline of the fuel manifold.

In a fifth embodiment, a system includes a turbine combustor fuel manifold configured to mount within a head end chamber of a turbine combustor. The turbine combustor fuel manifold includes a first radial fuel inlet coupled to a first fuel path and the first fuel path includes a first radial path and a first circumferential path disposed about a centerline of the turbine combustor fuel manifold.

In a sixth embodiment, a system includes an end plate of a combustor of a stoichiometric exhaust gas recirculation (SEGR) gas turbine engine. The end plate

includes at least one of an axial oxidant inlet or an axial exhaust outlet.

In a seventh embodiment, a method includes routing a fuel through a head end portion of a turbine combustor, routing an oxidant through the head end portion of the turbine combustor, routing an exhaust gas through the head end portion of the turbine combustor, and combusting a mixture of the fuel, the oxidant, and the exhaust gas in a combustion portion of the turbine combustor. The at least one of the oxidant or the exhaust gas passes through an end plate of the head end portion of the turbine combustor.

BRIEF DESCRIPTION OF THE DRAWINGS

These and other features, aspects, and advantages of the present invention will become better understood when the following detailed description is read with reference to the accompanying drawings in which like characters represent like parts throughout the drawings, wherein:

FIG. 1 is a diagram of an embodiment of a system having a turbine-based service system coupled to a hydrocarbon production system;

FIG. 2 is a diagram of an embodiment of the system of FIG. 1, further illustrating a control system and a combined cycle system;

FIG. 3 is a diagram of an embodiment of the system of FIGS. 1 and 2, further illustrating details of a gas turbine engine, exhaust gas supply system, and exhaust gas processing system;

FIG. 4 is a flow chart of an embodiment of a process for operating the system of FIGS. 1-3;

FIG. 5 is a flow chart of an embodiment of a process for operating a turbine-based service system;

FIG. 6 is a schematic diagram of an embodiment of a combustor section of a gas turbine engine;

FIG. 7 is a schematic diagram of an embodiment of a turbine combustor with an axial oxidant port;

FIG. 8 is a partial cross-sectional side view of an embodiment of a fuel manifold and fuel nozzle of the turbine combustor taken within line 8-8 of FIG. 7;

FIG. 9 is a cross-sectional end view of an embodiment of a fuel manifold;

FIG. 10 is a perspective view of an embodiment of an end plate and a fuel

manifold;

FIG. 11 is a schematic diagram of an embodiment of a turbine combustor with a peripheral oxidant port and a peripheral exhaust extraction port;

FIG. 12 is a cross-sectional end view of an embodiment of an end plate of the combustor of FIG. 11, illustrating two peripheral ports;

FIG. 13 is a cross-sectional end view of an embodiment of an end plate of the combustor of FIG. 11, illustrating four peripheral ports;

FIG. 14 is a schematic diagram of an embodiment of a combustor with peripheral exhaust extraction ports and a central oxidant port;

FIG. 15 is a cross-sectional end view of an embodiment of an end plate of the combustor of FIG. 14, illustrating two peripheral ports about a central port;

FIG. 16 is a cross-sectional end view of an embodiment of an end plate of the combustor of FIG. 14, illustrating four peripheral ports about a central port;

FIG. 17 is a partial cross-sectional side view of an embodiment of a head end portion of a turbine combustor taken within line 17-17 of FIG. 14;

FIG. 18 is a cross-sectional end view of an embodiment of a fuel manifold of the combustor of FIG. 14;

FIG. 19 is a schematic diagram of an embodiment of a turbine combustor with two radial exhaust extraction ports and an axial oxidant port; and

FIG. 20 is a partial cross-sectional side view of an embodiment of a head end portion of a turbine combustor with two exhaust extraction ports taken within line 20-20 of FIG. 19.

DETAILED DESCRIPTION OF THE INVENTION

One or more specific embodiments of the present invention will be described below. In an effort to provide a concise description of these embodiments, all features of an actual implementation may not be described in the specification. It should be appreciated that in the development of any such actual implementation, as in any engineering or design project, numerous implementation-specific decisions must be made to achieve the developers' specific goals, such as compliance with system-related and business-related constraints, which may vary from one implementation to another. Moreover, it should be appreciated that such a development effort might be complex and time consuming, but would nevertheless be a routine undertaking of design,

fabrication, and manufacture for those of ordinary skill having the benefit of this disclosure.

When introducing elements of various embodiments of the present invention, the articles “a,” “an,” “the,” and “said” are intended to mean that there are one or more
5 of the elements. The terms “comprising,” “including,” and “having” are intended to be inclusive and mean that there may be additional elements other than the listed elements.

As discussed in detail below, the disclosed embodiments relate generally to gas turbine systems with exhaust gas recirculation (EGR), and particularly stoichiometric
10 operation of the gas turbine systems using EGR. For example, the gas turbine systems may be configured to recirculate the exhaust gas along an exhaust recirculation path, stoichiometrically combust fuel and oxidant along with at least some of the recirculated exhaust gas, and capture the exhaust gas for use in various target systems. The recirculation of the exhaust gas along with stoichiometric combustion may help to
15 increase the concentration level of carbon dioxide (CO₂) in the exhaust gas, which can then be post treated to separate and purify the CO₂ and nitrogen (N₂) for use in various target systems. The gas turbine systems also may employ various exhaust gas processing (e.g., heat recovery, catalyst reactions, etc.) along the exhaust recirculation path, thereby increasing the concentration level of CO₂, reducing concentration levels
20 of other emissions (e.g., carbon monoxide, nitrogen oxides, and unburnt hydrocarbons), and increasing energy recovery (e.g., with heat recovery units). Furthermore, the gas turbine engines may be configured to combust the fuel and oxidant with one or more diffusion flames (e.g., using diffusion fuel nozzles), premix flames (e.g., using premix fuel nozzles), or any combination thereof. In certain
25 embodiments, the diffusion flames may help to maintain stability and operation within certain limits for stoichiometric combustion, which in turn helps to increase production of CO₂. For example, a gas turbine system operating with diffusion flames may enable a greater quantity of EGR, as compared to a gas turbine system operating with premix flames. In turn, the increased quantity of EGR helps to increase CO₂ production.
30 Possible target systems include pipelines, storage tanks, carbon sequestration systems, and hydrocarbon production systems, such as enhanced oil recovery (EOR) systems.

The disclosed embodiments provide systems and methods for turbine

combustors of gas turbine systems with EGR. Specifically, the turbine combustor may include a head end portion having a head end chamber and a combustion portion having a combustion chamber disposed downstream from the head end chamber. The head end portion includes an exhaust gas path, a fuel path, and an oxidant path. The turbine combustor may also include a cap disposed between the head end chamber and the combustion chamber. Further, the turbine combustor may include an end plate having at least one port coupled to the exhaust gas path or the oxidant path. The head end chamber may be disposed axially between the cap and the end plate. In certain embodiments, the turbine combustor may also include a fuel manifold disposed between the cap and the end plate. The fuel manifold may include a first radial fuel inlet coupled to a first fuel path of the fuel path and the first fuel path may include a first radial path and a first circumferential path disposed about a centerline of the fuel manifold.

By including the at least one port disposed on the end plate coupled to the exhaust gas path or the oxidant path, the turbine combustor may offer several advantages, especially for gas turbine systems with EGR. For example, uniform extraction or injection of the exhaust gas may provide lower pressure losses in the gas turbine system. In addition, uniform distribution of fluids, such as the oxidant and/or the exhaust gas, in the turbine combustor may cause temperature fields in the turbine combustor to be uniform for particular structural elements, such as the end plate and/or the casing of the turbine combustor. Further, the uniform distribution of fluids in the turbine combustor may improve the overall durability of the turbine combustor. Moreover, by providing the fuel manifold within the turbine combustor, the amount and number of external manifolds to the turbine combustor may be reduced, thereby improving maintenance accessibility.

FIG. 1 is a diagram of an embodiment of a system 10 having an hydrocarbon production system 12 associated with a turbine-based service system 14. As discussed in further detail below, various embodiments of the turbine-based service system 14 are configured to provide various services, such as electrical power, mechanical power, and fluids (e.g., exhaust gas), to the hydrocarbon production system 12 to facilitate the production or retrieval of oil and/or gas. In the illustrated embodiment, the hydrocarbon production system 12 includes an oil/gas extraction system 16 and an

enhanced oil recovery (EOR) system 18, which are coupled to a subterranean reservoir 20 (e.g., an oil, gas, or hydrocarbon reservoir). The oil/gas extraction system 16 includes a variety of surface equipment 22, such as a Christmas tree or production tree 24, coupled to an oil/gas well 26. Furthermore, the well 26 may include one or more tubulars 28 extending through a drilled bore 30 in the earth 32 to the subterranean reservoir 20. The tree 24 includes one or more valves, chokes, isolation sleeves, blowout preventers, and various flow control devices, which regulate pressures and control flows to and from the subterranean reservoir 20. While the tree 24 is generally used to control the flow of the production fluid (e.g., oil or gas) out of the subterranean reservoir 20, the EOR system 18 may increase the production of oil or gas by injecting one or more fluids into the subterranean reservoir 20.

Accordingly, the EOR system 18 may include a fluid injection system 34, which has one or more tubulars 36 extending through a bore 38 in the earth 32 to the subterranean reservoir 20. For example, the EOR system 18 may route one or more fluids 40, such as gas, steam, water, chemicals, or any combination thereof, into the fluid injection system 34. For example, as discussed in further detail below, the EOR system 18 may be coupled to the turbine-based service system 14, such that the system 14 routes an exhaust gas 42 (e.g., substantially or entirely free of oxygen) to the EOR system 18 for use as the injection fluid 40. The fluid injection system 34 routes the fluid 40 (e.g., the exhaust gas 42) through the one or more tubulars 36 into the subterranean reservoir 20, as indicated by arrows 44. The injection fluid 40 enters the subterranean reservoir 20 through the tubular 36 at an offset distance 46 away from the tubular 28 of the oil/gas well 26. Accordingly, the injection fluid 40 displaces the oil/gas 48 disposed in the subterranean reservoir 20, and drives the oil/gas 48 up through the one or more tubulars 28 of the hydrocarbon production system 12, as indicated by arrows 50. As discussed in further detail below, the injection fluid 40 may include the exhaust gas 42 originating from the turbine-based service system 14, which is able to generate the exhaust gas 42 on-site as needed by the hydrocarbon production system 12. In other words, the turbine-based system 14 may simultaneously generate one or more services (e.g., electrical power, mechanical power, steam, water (e.g., desalinated water), and exhaust gas (e.g., substantially free of oxygen)) for use by the hydrocarbon production system 12, thereby reducing or eliminating the reliance on

external sources of such services.

In the illustrated embodiment, the turbine-based service system 14 includes a stoichiometric exhaust gas recirculation (SEGR) gas turbine system 52 and an exhaust gas (EG) processing system 54. The gas turbine system 52 may be configured to
5 operate in a stoichiometric combustion mode of operation (e.g., a stoichiometric control mode) and a non-stoichiometric combustion mode of operation (e.g., a non-stoichiometric control mode), such as a fuel-lean control mode or a fuel-rich control mode. In the stoichiometric control mode, the combustion generally occurs in a substantially stoichiometric ratio of a fuel and oxidant, thereby resulting in
10 substantially stoichiometric combustion. In particular, stoichiometric combustion generally involves consuming substantially all of the fuel and oxidant in the combustion reaction, such that the products of combustion are substantially or entirely free of unburnt fuel and oxidant. One measure of stoichiometric combustion is the equivalence ratio, or phi (ϕ), which is the ratio of the actual fuel/oxidant ratio relative
15 to the stoichiometric fuel/oxidant ratio. An equivalence ratio of greater than 1.0 results in a fuel-rich combustion of the fuel and oxidant, whereas an equivalence ratio of less than 1.0 results in a fuel-lean combustion of the fuel and oxidant. In contrast, an equivalence ratio of 1.0 results in combustion that is neither fuel-rich nor fuel-lean, thereby substantially consuming all of the fuel and oxidant in the combustion reaction.
20 In context of the disclosed embodiments, the term stoichiometric or substantially stoichiometric may refer to an equivalence ratio of approximately 0.95 to approximately 1.05. However, the disclosed embodiments may also include an equivalence ratio of 1.0 plus or minus 0.01, 0.02, 0.03, 0.04, 0.05, or more. Again, the stoichiometric combustion of fuel and oxidant in the turbine-based service system 14
25 may result in products of combustion or exhaust gas (e.g., 42) with substantially no unburnt fuel or oxidant remaining. For example, the exhaust gas 42 may have less than 1, 2, 3, 4, or 5 percent by volume of oxidant (e.g., oxygen), unburnt fuel or hydrocarbons (e.g., HCs), nitrogen oxides (e.g., NO_x), carbon monoxide (CO), sulfur oxides (e.g., SO_x), hydrogen, and other products of incomplete combustion. By further
30 example, the exhaust gas 42 may have less than approximately 10, 20, 30, 40, 50, 60, 70, 80, 90, 100, 200, 300, 400, 500, 1000, 2000, 3000, 4000, or 5000 parts per million by volume (ppmv) of oxidant (e.g., oxygen), unburnt fuel or hydrocarbons (e.g., HCs),

nitrogen oxides (e.g., NO_x), carbon monoxide (CO), sulfur oxides (e.g., SO_x), hydrogen, and other products of incomplete combustion. However, the disclosed embodiments also may produce other ranges of residual fuel, oxidant, and other emissions levels in the exhaust gas 42. As used herein, the terms emissions, emissions
5 levels, and emissions targets may refer to concentration levels of certain products of combustion (e.g., NO_x, CO, SO_x, O₂, N₂, H₂, HCs, etc.), which may be present in recirculated gas streams, vented gas streams (e.g., exhausted into the atmosphere), and gas streams used in various target systems (e.g., the hydrocarbon production system 12).

10 Although the SEGR gas turbine system 52 and the EG processing system 54 may include a variety of components in different embodiments, the illustrated EG processing system 54 includes a heat recovery steam generator (HRSG) 56 and an exhaust gas recirculation (EGR) system 58, which receive and process an exhaust gas
15 60 originating from the SEGR gas turbine system 52. The HRSG 56 may include one or more heat exchangers, condensers, and various heat recovery equipment, which collectively function to transfer heat from the exhaust gas 60 to a stream of water, thereby generating steam 62. The steam 62 may be used in one or more steam turbines, the EOR system 18, or any other portion of the hydrocarbon production system 12. For example, the HRSG 56 may generate low pressure, medium pressure, and/or high
20 pressure steam 62, which may be selectively applied to low, medium, and high pressure steam turbine stages, or different applications of the EOR system 18. In addition to the steam 62, a treated water 64, such as a desalinated water, may be generated by the HRSG 56, the EGR system 58, and/or another portion of the EG processing system 54 or the SEGR gas turbine system 52. The treated water 64 (e.g.,
25 desalinated water) may be particularly useful in areas with water shortages, such as inland or desert regions. The treated water 64 may be generated, at least in part, due to the large volume of air driving combustion of fuel within the SEGR gas turbine system 52. While the on-site generation of steam 62 and water 64 may be beneficial in many applications (including the hydrocarbon production system 12), the on-site generation
30 of exhaust gas 42, 60 may be particularly beneficial for the EOR system 18, due to its low oxygen content, high pressure, and heat derived from the SEGR gas turbine system 52. Accordingly, the HRSG 56, the EGR system 58, and/or another portion of

the EG processing system 54 may output or recirculate an exhaust gas 66 into the SEGR gas turbine system 52, while also routing the exhaust gas 42 to the EOR system 18 for use with the hydrocarbon production system 12. Likewise, the exhaust gas 42 may be extracted directly from the SEGR gas turbine system 52 (i.e., without passing through the EG processing system 54) for use in the EOR system 18 of the hydrocarbon production system 12.

The exhaust gas recirculation is handled by the EGR system 58 of the EG processing system 54. For example, the EGR system 58 includes one or more conduits, valves, blowers, exhaust gas treatment systems (e.g., filters, particulate removal units, gas separation units, gas purification units, heat exchangers, heat recovery units, moisture removal units, catalyst units, chemical injection units, or any combination thereof), and controls to recirculate the exhaust gas along an exhaust gas circulation path from an output (e.g., discharged exhaust gas 60) to an input (e.g., intake exhaust gas 66) of the SEGR gas turbine system 52. In the illustrated embodiment, the SEGR gas turbine system 52 intakes the exhaust gas 66 into a compressor section having one or more compressors, thereby compressing the exhaust gas 66 for use in a combustor section along with an intake of an oxidant 68 and one or more fuels 70. The oxidant 68 may include ambient air, pure oxygen, oxygen-enriched air, oxygen-reduced air, oxygen-nitrogen mixtures, or any suitable oxidant that facilitates combustion of the fuel 70. The fuel 70 may include one or more gas fuels, liquid fuels, or any combination thereof. For example, the fuel 70 may include natural gas, liquefied natural gas (LNG), syngas, methane, ethane, propane, butane, naphtha, kerosene, diesel fuel, ethanol, methanol, biofuel, or any combination thereof.

The SEGR gas turbine system 52 mixes and combusts the exhaust gas 66, the oxidant 68, and the fuel 70 in the combustor section, thereby generating hot combustion gases or exhaust gas 60 to drive one or more turbine stages in a turbine section. In certain embodiments, each combustor in the combustor section includes one or more premix fuel nozzles, one or more diffusion fuel nozzles, or any combination thereof. For example, each premix fuel nozzle may be configured to mix the oxidant 68 and the fuel 70 internally within the fuel nozzle and/or partially upstream of the fuel nozzle, thereby injecting an oxidant-fuel mixture from the fuel nozzle into the combustion zone for a premixed combustion (e.g., a premixed flame). By further

example, each diffusion fuel nozzle may be configured to isolate the flows of oxidant 68 and fuel 70 within the fuel nozzle, thereby separately injecting the oxidant 68 and the fuel 70 from the fuel nozzle into the combustion zone for diffusion combustion (e.g., a diffusion flame). In particular, the diffusion combustion provided by the diffusion fuel nozzles delays mixing of the oxidant 68 and the fuel 70 until the point of initial combustion, i.e., the flame region. In embodiments employing the diffusion fuel nozzles, the diffusion flame may provide increased flame stability, because the diffusion flame generally forms at the point of stoichiometry between the separate streams of oxidant 68 and fuel 70 (i.e., as the oxidant 68 and fuel 70 are mixing). In certain embodiments, one or more diluents (e.g., the exhaust gas 60, steam, nitrogen, or another inert gas) may be pre-mixed with the oxidant 68, the fuel 70, or both, in either the diffusion fuel nozzle or the premix fuel nozzle. In addition, one or more diluents (e.g., the exhaust gas 60, steam, nitrogen, or another inert gas) may be injected into the combustor at or downstream from the point of combustion within each combustor. The use of these diluents may help temper the flame (e.g., premix flame or diffusion flame), thereby helping to reduce NO_x emissions, such as nitrogen monoxide (NO) and nitrogen dioxide (NO₂). Regardless of the type of flame, the combustion produces hot combustion gases or exhaust gas 60 to drive one or more turbine stages. As each turbine stage is driven by the exhaust gas 60, the SEGR gas turbine system 52 generates a mechanical power 72 and/or an electrical power 74 (e.g., via an electrical generator). The system 52 also outputs the exhaust gas 60, and may further output water 64. Again, the water 64 may be a treated water, such as a desalinated water, which may be useful in a variety of applications on-site or off-site.

Exhaust extraction is also provided by the SEGR gas turbine system 52 using one or more extraction points 76. For example, the illustrated embodiment includes an exhaust gas (EG) supply system 78 having an exhaust gas (EG) extraction system 80 and an exhaust gas (EG) treatment system 82, which receive exhaust gas 42 from the extraction points 76, treat the exhaust gas 42, and then supply or distribute the exhaust gas 42 to various target systems. The target systems may include the EOR system 18 and/or other systems, such as a pipeline 86, a storage tank 88, or a carbon sequestration system 90. The EG extraction system 80 may include one or more conduits, valves, controls, and flow separations, which facilitate isolation of the exhaust gas 42 from the

oxidant 68, the fuel 70, and other contaminants, while also controlling the temperature, pressure, and flow rate of the extracted exhaust gas 42. The EG treatment system 82 may include one or more heat exchangers (e.g., heat recovery units such as heat recovery steam generators, condensers, coolers, or heaters), catalyst systems (e.g., oxidation catalyst systems), particulate and/or water removal systems (e.g., gas dehydration units, inertial separators, coalescing filters, water impermeable filters, and other filters), chemical injection systems, solvent based treatment systems (e.g., absorbers, flash tanks, etc.), carbon capture systems, gas separation systems, gas purification systems, and/or a solvent based treatment system, exhaust gas compressors, any combination thereof. These subsystems of the EG treatment system 82 enable control of the temperature, pressure, flow rate, moisture content (e.g., amount of water removal), particulate content (e.g., amount of particulate removal), and gas composition (e.g., percentage of CO₂, N₂, etc.).

The extracted exhaust gas 42 is treated by one or more subsystems of the EG treatment system 82, depending on the target system. For example, the EG treatment system 82 may direct all or part of the exhaust gas 42 through a carbon capture system, a gas separation system, a gas purification system, and/or a solvent based treatment system, which is controlled to separate and purify a carbonaceous gas (e.g., carbon dioxide) 92 and/or nitrogen (N₂) 94 for use in the various target systems. For example, embodiments of the EG treatment system 82 may perform gas separation and purification to produce a plurality of different streams 95 of exhaust gas 42, such as a first stream 96, a second stream 97, and a third stream 98. The first stream 96 may have a first composition that is rich in carbon dioxide and/or lean in nitrogen (e.g., a CO₂ rich, N₂ lean stream). The second stream 97 may have a second composition that has intermediate concentration levels of carbon dioxide and/or nitrogen (e.g., intermediate concentration CO₂, N₂ stream). The third stream 98 may have a third composition that is lean in carbon dioxide and/or rich in nitrogen (e.g., a CO₂ lean, N₂ rich stream). Each stream 95 (e.g., 96, 97, and 98) may include a gas dehydration unit, a filter, a gas compressor, or any combination thereof, to facilitate delivery of the stream 95 to a target system. In certain embodiments, the CO₂ rich, N₂ lean stream 96 may have a CO₂ purity or concentration level of greater than approximately 70, 75, 80, 85, 90, 95, 96, 97, 98, or 99 percent by volume, and a N₂ purity or concentration level

of less than approximately 1, 2, 3, 4, 5, 10, 15, 20, 25, or 30 percent by volume. In contrast, the CO₂ lean, N₂ rich stream 98 may have a CO₂ purity or concentration level of less than approximately 1, 2, 3, 4, 5, 10, 15, 20, 25, or 30 percent by volume, and a N₂ purity or concentration level of greater than approximately 70, 75, 80, 85, 90, 95, 5 96, 97, 98, or 99 percent by volume. The intermediate concentration CO₂, N₂ stream 97 may have a CO₂ purity or concentration level and/or a N₂ purity or concentration level of between approximately 30 to 70, 35 to 65, 40 to 60, or 45 to 55 percent by volume. Although the foregoing ranges are merely non-limiting examples, the CO₂ rich, N₂ lean stream 96 and the CO₂ lean, N₂ rich stream 98 may be particularly well suited for use with the EOR system 18 and the other systems 84. However, any of these rich, lean, or intermediate concentration CO₂ streams 95 may be used, alone or in various combinations, with the EOR system 18 and the other systems 84. For example, the EOR system 18 and the other systems 84 (e.g., the pipeline 86, storage tank 88, and the carbon sequestration system 90) each may receive one or more CO₂ rich, N₂ lean 10 streams 96, one or more CO₂ lean, N₂ rich streams 98, one or more intermediate concentration CO₂, N₂ streams 97, and one or more untreated exhaust gas 42 streams (i.e., bypassing the EG treatment system 82).

The EG extraction system 80 extracts the exhaust gas 42 at one or more extraction points 76 along the compressor section, the combustor section, and/or the turbine section, such that the exhaust gas 42 may be used in the EOR system 18 and other systems 84 at suitable temperatures and pressures. The EG extraction system 80 and/or the EG treatment system 82 also may circulate fluid flows (e.g., exhaust gas 42) to and from the EG processing system 54. For example, a portion of the exhaust gas 42 passing through the EG processing system 54 may be extracted by the EG extraction 20 system 80 for use in the EOR system 18 and the other systems 84. In certain embodiments, the EG supply system 78 and the EG processing system 54 may be independent or integral with one another, and thus may use independent or common subsystems. For example, the EG treatment system 82 may be used by both the EG supply system 78 and the EG processing system 54. Exhaust gas 42 extracted from the 25 EG processing system 54 may undergo multiple stages of gas treatment, such as one or more stages of gas treatment in the EG processing system 54 followed by one or more additional stages of gas treatment in the EG treatment system 82. 30

At each extraction point 76, the extracted exhaust gas 42 may be substantially free of oxidant 68 and fuel 70 (e.g., unburnt fuel or hydrocarbons) due to substantially stoichiometric combustion and/or gas treatment in the EG processing system 54. Furthermore, depending on the target system, the extracted exhaust gas 42 may undergo further treatment in the EG treatment system 82 of the EG supply system 78, 5 thereby further reducing any residual oxidant 68, fuel 70, or other undesirable products of combustion. For example, either before or after treatment in the EG treatment system 82, the extracted exhaust gas 42 may have less than 1, 2, 3, 4, or 5 percent by volume of oxidant (e.g., oxygen), unburnt fuel or hydrocarbons (e.g., HCs), nitrogen 10 oxides (e.g., NO_x), carbon monoxide (CO), sulfur oxides (e.g., SO_x), hydrogen, and other products of incomplete combustion. By further example, either before or after treatment in the EG treatment system 82, the extracted exhaust gas 42 may have less than approximately 10, 20, 30, 40, 50, 60, 70, 80, 90, 100, 200, 300, 400, 500, 1000, 2000, 3000, 4000, or 5000 parts per million by volume (ppmv) of oxidant (e.g., 15 oxygen), unburnt fuel or hydrocarbons (e.g., HCs), nitrogen oxides (e.g., NO_x), carbon monoxide (CO), sulfur oxides (e.g., SO_x), hydrogen, and other products of incomplete combustion. Thus, the exhaust gas 42 is particularly well suited for use with the EOR system 18.

The EGR operation of the turbine system 52 specifically enables the exhaust 20 extraction at a multitude of locations 76. For example, the compressor section of the system 52 may be used to compress the exhaust gas 66 without any oxidant 68 (i.e., only compression of the exhaust gas 66), such that a substantially oxygen-free exhaust gas 42 may be extracted from the compressor section and/or the combustor section prior to entry of the oxidant 68 and the fuel 70. The extraction points 76 may be 25 located at interstage ports between adjacent compressor stages, at ports along the compressor discharge casing, at ports along each combustor in the combustor section, or any combination thereof. In certain embodiments, the exhaust gas 66 may not mix with the oxidant 68 and fuel 70 until it reaches the head end portion and/or fuel nozzles of each combustor in the combustor section. Furthermore, one or more flow separators 30 (e.g., walls, dividers, baffles, or the like) may be used to isolate the oxidant 68 and the fuel 70 from the extraction points 76. With these flow separators, the extraction points 76 may be disposed directly along a wall of each combustor in the combustor section.

Once the exhaust gas 66, oxidant 68, and fuel 70 flow through the head end portion (e.g., through fuel nozzles) into the combustion portion (e.g., combustion chamber) of each combustor, the SEGR gas turbine system 52 is controlled to provide a substantially stoichiometric combustion of the exhaust gas 66, oxidant 68, and fuel 70. For example, the system 52 may maintain an equivalence ratio of approximately 0.95 to approximately 1.05. As a result, the products of combustion of the mixture of exhaust gas 66, oxidant 68, and fuel 70 in each combustor is substantially free of oxygen and unburnt fuel. Thus, the products of combustion (or exhaust gas) may be extracted from the turbine section of the SEGR gas turbine system 52 for use as the exhaust gas 42 routed to the EOR system 18. Along the turbine section, the extraction points 76 may be located at any turbine stage, such as interstage ports between adjacent turbine stages. Thus, using any of the foregoing extraction points 76, the turbine-based service system 14 may generate, extract, and deliver the exhaust gas 42 to the hydrocarbon production system 12 (e.g., the EOR system 18) for use in the production of oil/gas 48 from the subterranean reservoir 20.

FIG. 2 is a diagram of an embodiment of the system 10 of FIG. 1, illustrating a control system 100 coupled to the turbine-based service system 14 and the hydrocarbon production system 12. In the illustrated embodiment, the turbine-based service system 14 includes a combined cycle system 102, which includes the SEGR gas turbine system 52 as a topping cycle, a steam turbine 104 as a bottoming cycle, and the HRSG 56 to recover heat from the exhaust gas 60 to generate the steam 62 for driving the steam turbine 104. Again, the SEGR gas turbine system 52 receives, mixes, and stoichiometrically combusts the exhaust gas 66, the oxidant 68, and the fuel 70 (e.g., premix and/or diffusion flames), thereby producing the exhaust gas 60, the mechanical power 72, the electrical power 74, and/or the water 64. For example, the SEGR gas turbine system 52 may drive one or more loads or machinery 106, such as an electrical generator, an oxidant compressor (e.g., a main air compressor), a gear box, a pump, equipment of the hydrocarbon production system 12, or any combination thereof. In some embodiments, the machinery 106 may include other drives, such as electrical motors or steam turbines (e.g., the steam turbine 104), in tandem with the SEGR gas turbine system 52. Accordingly, an output of the machinery 106 driven by the SEGR gas turbines system 52 (and any additional drives) may include the

mechanical power 72 and the electrical power 74. The mechanical power 72 and/or the electrical power 74 may be used on-site for powering the hydrocarbon production system 12, the electrical power 74 may be distributed to the power grid, or any combination thereof. The output of the machinery 106 also may include a compressed
5 fluid, such as a compressed oxidant 68 (e.g., air or oxygen), for intake into the combustion section of the SEGR gas turbine system 52. Each of these outputs (e.g., the exhaust gas 60, the mechanical power 72, the electrical power 74, and/or the water 64) may be considered a service of the turbine-based service system 14.

The SEGR gas turbine system 52 produces the exhaust gas 42, 60, which may
10 be substantially free of oxygen, and routes this exhaust gas 42, 60 to the EG processing system 54 and/or the EG supply system 78. The EG supply system 78 may treat and delivery the exhaust gas 42 (e.g., streams 95) to the hydrocarbon production system 12 and/or the other systems 84. As discussed above, the EG processing system 54 may include the HRSG 56 and the EGR system 58. The HRSG 56 may include one or more
15 heat exchangers, condensers, and various heat recovery equipment, which may be used to recover or transfer heat from the exhaust gas 60 to water 108 to generate the steam 62 for driving the steam turbine 104. Similar to the SEGR gas turbine system 52, the steam turbine 104 may drive one or more loads or machinery 106, thereby generating the mechanical power 72 and the electrical power 74. In the illustrated embodiment,
20 the SEGR gas turbine system 52 and the steam turbine 104 are arranged in tandem to drive the same machinery 106. However, in other embodiments, the SEGR gas turbine system 52 and the steam turbine 104 may separately drive different machinery 106 to independently generate mechanical power 72 and/or electrical power 74. As the steam turbine 104 is driven by the steam 62 from the HRSG 56, the steam 62 gradually
25 decreases in temperature and pressure. Accordingly, the steam turbine 104 recirculates the used steam 62 and/or water 108 back into the HRSG 56 for additional steam generation via heat recovery from the exhaust gas 60. In addition to steam generation, the HRSG 56, the EGR system 58, and/or another portion of the EG processing system 54 may produce the water 64, the exhaust gas 42 for use with the hydrocarbon
30 production system 12, and the exhaust gas 66 for use as an input into the SEGR gas turbine system 52. For example, the water 64 may be a treated water 64, such as a desalinated water for use in other applications. The desalinated water may be

particularly useful in regions of low water availability. Regarding the exhaust gas 60, embodiments of the EG processing system 54 may be configured to recirculate the exhaust gas 60 through the EGR system 58 with or without passing the exhaust gas 60 through the HRSG 56.

5 In the illustrated embodiment, the SEGR gas turbine system 52 has an exhaust recirculation path 110, which extends from an exhaust outlet to an exhaust inlet of the system 52. Along the path 110, the exhaust gas 60 passes through the EG processing system 54, which includes the HRSG 56 and the EGR system 58 in the illustrated embodiment. The EGR system 58 may include one or more conduits, valves, blowers,
10 gas treatment systems (e.g., filters, particulate removal units, gas separation units, gas purification units, heat exchangers, heat recovery units such as heat recovery steam generators, moisture removal units, catalyst units, chemical injection units, or any combination thereof) in series and/or parallel arrangements along the path 110. In other words, the EGR system 58 may include any flow control components, pressure control
15 components, temperature control components, moisture control components, and gas composition control components along the exhaust recirculation path 110 between the exhaust outlet and the exhaust inlet of the system 52. Accordingly, in embodiments with the HRSG 56 along the path 110, the HRSG 56 may be considered a component of the EGR system 58. However, in certain embodiments, the HRSG 56 may be
20 disposed along an exhaust path independent from the exhaust recirculation path 110. Regardless of whether the HRSG 56 is along a separate path or a common path with the EGR system 58, the HRSG 56 and the EGR system 58 intake the exhaust gas 60 and output either the recirculated exhaust gas 66, the exhaust gas 42 for use with the EG supply system 78 (e.g., for the hydrocarbon production system 12 and/or other
25 systems 84), or another output of exhaust gas. Again, the SEGR gas turbine system 52 intakes, mixes, and stoichiometrically combusts the exhaust gas 66, the oxidant 68, and the fuel 70 (e.g., premixed and/or diffusion flames) to produce a substantially oxygen-free and fuel-free exhaust gas 60 for distribution to the EG processing system 54, the hydrocarbon production system 12, or other systems 84.

30 As noted above with reference to FIG. 1, the hydrocarbon production system 12 may include a variety of equipment to facilitate the recovery or production of oil/gas 48 from a subterranean reservoir 20 through an oil/gas well 26. For example, the

hydrocarbon production system 12 may include the EOR system 18 having the fluid injection system 34. In the illustrated embodiment, the fluid injection system 34 includes an exhaust gas injection EOR system 112 and a steam injection EOR system 114. Although the fluid injection system 34 may receive fluids from a variety of sources, the illustrated embodiment may receive the exhaust gas 42 and the steam 62 from the turbine-based service system 14. The exhaust gas 42 and/or the steam 62 produced by the turbine-based service system 14 also may be routed to the hydrocarbon production system 12 for use in other oil/gas systems 116.

The quantity, quality, and flow of the exhaust gas 42 and/or the steam 62 may be controlled by the control system 100. The control system 100 may be dedicated entirely to the turbine-based service system 14, or the control system 100 may optionally also provide control (or at least some data to facilitate control) for the hydrocarbon production system 12 and/or other systems 84. In the illustrated embodiment, the control system 100 includes a controller 118 having a processor 120, a memory 122, a steam turbine control 124, a SEGR gas turbine system control 126, and a machinery control 128. The processor 120 may include a single processor or two or more redundant processors, such as triple redundant processors for control of the turbine-based service system 14. The memory 122 may include volatile and/or non-volatile memory. For example, the memory 122 may include one or more hard drives, flash memory, read-only memory, random access memory, or any combination thereof. The controls 124, 126, and 128 may include software and/or hardware controls. For example, the controls 124, 126, and 128 may include various instructions or code stored on the memory 122 and executable by the processor 120. The control 124 is configured to control operation of the steam turbine 104, the SEGR gas turbine system control 126 is configured to control the system 52, and the machinery control 128 is configured to control the machinery 106. Thus, the controller 118 (e.g., controls 124, 126, and 128) may be configured to coordinate various sub-systems of the turbine-based service system 14 to provide a suitable stream of the exhaust gas 42 to the hydrocarbon production system 12.

In certain embodiments of the control system 100, each element (e.g., system, subsystem, and component) illustrated in the drawings or described herein includes (e.g., directly within, upstream, or downstream of such element) one or more industrial

control features, such as sensors and control devices, which are communicatively coupled with one another over an industrial control network along with the controller 118. For example, the control devices associated with each element may include a dedicated device controller (e.g., including a processor, memory, and control instructions), one or more actuators, valves, switches, and industrial control equipment, which enable control based on sensor feedback 130, control signals from the controller 118, control signals from a user, or any combination thereof. Thus, any of the control functionality described herein may be implemented with control instructions stored and/or executable by the controller 118, dedicated device controllers associated with each element, or a combination thereof.

In order to facilitate such control functionality, the control system 100 includes one or more sensors distributed throughout the system 10 to obtain the sensor feedback 130 for use in execution of the various controls, e.g., the controls 124, 126, and 128. For example, the sensor feedback 130 may be obtained from sensors distributed throughout the SEGR gas turbine system 52, the machinery 106, the EG processing system 54, the steam turbine 104, the hydrocarbon production system 12, or any other components throughout the turbine-based service system 14 or the hydrocarbon production system 12. For example, the sensor feedback 130 may include temperature feedback, pressure feedback, flow rate feedback, flame temperature feedback, combustion dynamics feedback, intake oxidant composition feedback, intake fuel composition feedback, exhaust composition feedback, the output level of mechanical power 72, the output level of electrical power 74, the output quantity of the exhaust gas 42, 60, the output quantity or quality of the water 64, or any combination thereof. For example, the sensor feedback 130 may include a composition of the exhaust gas 42, 60 to facilitate stoichiometric combustion in the SEGR gas turbine system 52. For example, the sensor feedback 130 may include feedback from one or more intake oxidant sensors along an oxidant supply path of the oxidant 68, one or more intake fuel sensors along a fuel supply path of the fuel 70, and one or more exhaust emissions sensors disposed along the exhaust recirculation path 110 and/or within the SEGR gas turbine system 52. The intake oxidant sensors, intake fuel sensors, and exhaust emissions sensors may include temperature sensors, pressure sensors, flow rate sensors, and composition sensors. The emissions sensors may includes sensors for

nitrogen oxides (e.g., NO_x sensors), carbon oxides (e.g., CO sensors and CO₂ sensors), sulfur oxides (e.g., SO_x sensors), hydrogen (e.g., H₂ sensors), oxygen (e.g., O₂ sensors), unburnt hydrocarbons (e.g., HC sensors), or other products of incomplete combustion, or any combination thereof.

5 Using this feedback 130, the control system 100 may adjust (e.g., increase, decrease, or maintain) the intake flow of exhaust gas 66, oxidant 68, and/or fuel 70 into the SEGR gas turbine system 52 (among other operational parameters) to maintain the equivalence ratio within a suitable range, e.g., between approximately 0.95 to approximately 1.05, between approximately 0.95 to approximately 1.0, between
10 approximately 1.0 to approximately 1.05, or substantially at 1.0. For example, the control system 100 may analyze the feedback 130 to monitor the exhaust emissions (e.g., concentration levels of nitrogen oxides, carbon oxides such as CO and CO₂, sulfur oxides, hydrogen, oxygen, unburnt hydrocarbons, and other products of incomplete combustion) and/or determine the equivalence ratio, and then control one
15 or more components to adjust the exhaust emissions (e.g., concentration levels in the exhaust gas 42) and/or the equivalence ratio. The controlled components may include any of the components illustrated and described with reference to the drawings, including but not limited to, valves along the supply paths for the oxidant 68, the fuel 70, and the exhaust gas 66; an oxidant compressor, a fuel pump, or any components in
20 the EG processing system 54; any components of the SEGR gas turbine system 52, or any combination thereof. The controlled components may adjust (e.g., increase, decrease, or maintain) the flow rates, temperatures, pressures, or percentages (e.g., equivalence ratio) of the oxidant 68, the fuel 70, and the exhaust gas 66 that combust within the SEGR gas turbine system 52. The controlled components also may include
25 one or more gas treatment systems, such as catalyst units (e.g., oxidation catalyst units), supplies for the catalyst units (e.g., oxidation fuel, heat, electricity, etc.), gas purification and/or separation units (e.g., solvent based separators, absorbers, flash tanks, etc.), and filtration units. The gas treatment systems may help reduce various exhaust emissions along the exhaust recirculation path 110, a vent path (e.g., exhausted
30 into the atmosphere), or an extraction path to the EG supply system 78.

In certain embodiments, the control system 100 may analyze the feedback 130 and control one or more components to maintain or reduce emissions levels (e.g.,

concentration levels in the exhaust gas 42, 60, 95) to a target range, such as less than approximately 10, 20, 30, 40, 50, 100, 200, 300, 400, 500, 1000, 2000, 3000, 4000, 5000, or 10000 parts per million by volume (ppmv). These target ranges may be the same or different for each of the exhaust emissions, e.g., concentration levels of

5 nitrogen oxides, carbon monoxide, sulfur oxides, hydrogen, oxygen, unburnt hydrocarbons, and other products of incomplete combustion. For example, depending on the equivalence ratio, the control system 100 may selectively control exhaust emissions (e.g., concentration levels) of oxidant (e.g., oxygen) within a target range of less than approximately 10, 20, 30, 40, 50, 60, 70, 80, 90, 100, 250, 500, 750, or 1000

10 ppmv; carbon monoxide (CO) within a target range of less than approximately 20, 50, 100, 200, 500, 1000, 2500, or 5000 ppmv; and nitrogen oxides (NO_x) within a target range of less than approximately 50, 100, 200, 300, 400, or 500 ppmv. In certain embodiments operating with a substantially stoichiometric equivalence ratio, the control system 100 may selectively control exhaust emissions (e.g., concentration

15 levels) of oxidant (e.g., oxygen) within a target range of less than approximately 10, 20, 30, 40, 50, 60, 70, 80, 90, or 100 ppmv; and carbon monoxide (CO) within a target range of less than approximately 500, 1000, 2000, 3000, 4000, or 5000 ppmv. In certain embodiments operating with a fuel-lean equivalence ratio (e.g., between approximately 0.95 to 1.0), the control system 100 may selectively control exhaust

20 emissions (e.g., concentration levels) of oxidant (e.g., oxygen) within a target range of less than approximately 500, 600, 700, 800, 900, 1000, 1100, 1200, 1300, 1400, or 1500 ppmv; carbon monoxide (CO) within a target range of less than approximately 10, 20, 30, 40, 50, 60, 70, 80, 90, 100, 150, or 200 ppmv; and nitrogen oxides (e.g., NO_x) within a target range of less than approximately 50, 100, 150, 200, 250, 300,

25 350, or 400 ppmv. The foregoing target ranges are merely examples, and are not intended to limit the scope of the disclosed embodiments.

The control system 100 also may be coupled to a local interface 132 and a remote interface 134. For example, the local interface 132 may include a computer workstation disposed on-site at the turbine-based service system 14 and/or the

30 hydrocarbon production system 12. In contrast, the remote interface 134 may include a computer workstation disposed off-site from the turbine-based service system 14 and the hydrocarbon production system 12, such as through an internet connection. These

interfaces 132 and 134 facilitate monitoring and control of the turbine-based service system 14, such as through one or more graphical displays of sensor feedback 130, operational parameters, and so forth.

Again, as noted above, the controller 118 includes a variety of controls 124, 5 126, and 128 to facilitate control of the turbine-based service system 14. The steam turbine control 124 may receive the sensor feedback 130 and output control commands to facilitate operation of the steam turbine 104. For example, the steam turbine control 124 may receive the sensor feedback 130 from the HRSG 56, the machinery 106, temperature and pressure sensors along a path of the steam 62, temperature and 10 pressure sensors along a path of the water 108, and various sensors indicative of the mechanical power 72 and the electrical power 74. Likewise, the SEGR gas turbine system control 126 may receive sensor feedback 130 from one or more sensors disposed along the SEGR gas turbine system 52, the machinery 106, the EG processing system 54, or any combination thereof. For example, the sensor feedback 15 130 may be obtained from temperature sensors, pressure sensors, clearance sensors, vibration sensors, flame sensors, fuel composition sensors, exhaust gas composition sensors, or any combination thereof, disposed within or external to the SEGR gas turbine system 52. Finally, the machinery control 128 may receive sensor feedback 130 from various sensors associated with the mechanical power 72 and the electrical power 20 74, as well as sensors disposed within the machinery 106. Each of these controls 124, 126, and 128 uses the sensor feedback 130 to improve operation of the turbine-based service system 14.

In the illustrated embodiment, the SEGR gas turbine system control 126 may execute instructions to control the quantity and quality of the exhaust gas 42, 60, 95 in 25 the EG processing system 54, the EG supply system 78, the hydrocarbon production system 12, and/or the other systems 84. For example, the SEGR gas turbine system control 126 may maintain a level of oxidant (e.g., oxygen) and/or unburnt fuel in the exhaust gas 60 below a threshold suitable for use with the exhaust gas injection EOR system 112. In certain embodiments, the threshold levels may be less than 1, 2, 3, 4, or 30 5 percent of oxidant (e.g., oxygen) and/or unburnt fuel by volume of the exhaust gas 42, 60; or the threshold levels of oxidant (e.g., oxygen) and/or unburnt fuel (and other exhaust emissions) may be less than approximately 10, 20, 30, 40, 50, 60, 70, 80, 90,

100, 200, 300, 400, 500, 1000, 2000, 3000, 4000, or 5000 parts per million by volume (ppmv) in the exhaust gas 42, 60. By further example, in order to achieve these low levels of oxidant (e.g., oxygen) and/or unburnt fuel, the SEGR gas turbine system control 126 may maintain an equivalence ratio for combustion in the SEGR gas turbine system 52 between approximately 0.95 and approximately 1.05. The SEGR gas turbine system control 126 also may control the EG extraction system 80 and the EG treatment system 82 to maintain the temperature, pressure, flow rate, and gas composition of the exhaust gas 42, 60, 95 within suitable ranges for the exhaust gas injection EOR system 112, the pipeline 86, the storage tank 88, and the carbon sequestration system 90. As discussed above, the EG treatment system 82 may be controlled to purify and/or separate the exhaust gas 42 into one or more gas streams 95, such as the CO₂ rich, N₂ lean stream 96, the intermediate concentration CO₂, N₂ stream 97, and the CO₂ lean, N₂ rich stream 98. In addition to controls for the exhaust gas 42, 60, and 95, the controls 124, 126, and 128 may execute one or more instructions to maintain the mechanical power 72 within a suitable power range, or maintain the electrical power 74 within a suitable frequency and power range.

FIG. 3 is a diagram of embodiment of the system 10, further illustrating details of the SEGR gas turbine system 52 for use with the hydrocarbon production system 12 and/or other systems 84. In the illustrated embodiment, the SEGR gas turbine system 52 includes a gas turbine engine 150 coupled to the EG processing system 54. The illustrated gas turbine engine 150 includes a compressor section 152, a combustor section 154, and an expander section or turbine section 156. The compressor section 152 includes one or more exhaust gas compressors or compressor stages 158, such as 1 to 20 stages of rotary compressor blades disposed in a series arrangement. Likewise, the combustor section 154 includes one or more combustors 160, such as 1 to 20 combustors 160 distributed circumferentially about a rotational axis 162 of the SEGR gas turbine system 52. Furthermore, each combustor 160 may include one or more fuel nozzles 164 configured to inject the exhaust gas 66, the oxidant 68, and/or the fuel 70. For example, a head end portion 166 of each combustor 160 may house 1, 2, 3, 4, 5, 6, or more fuel nozzles 164, which may inject streams or mixtures of the exhaust gas 66, the oxidant 68, and/or the fuel 70 into a combustion portion 168 (e.g., combustion chamber) of the combustor 160.

The fuel nozzles 164 may include any combination of premix fuel nozzles 164 (e.g., configured to premix the oxidant 68 and fuel 70 for generation of an oxidant/fuel premix flame) and/or diffusion fuel nozzles 164 (e.g., configured to inject separate flows of the oxidant 68 and fuel 70 for generation of an oxidant/fuel diffusion flame).

5 Embodiments of the premix fuel nozzles 164 may include swirl vanes, mixing chambers, or other features to internally mix the oxidant 68 and fuel 70 within the nozzles 164, prior to injection and combustion in the combustion chamber 168. The premix fuel nozzles 164 also may receive at least some partially mixed oxidant 68 and fuel 70. In certain embodiments, each diffusion fuel nozzle 164 may isolate flows of

10 the oxidant 68 and the fuel 70 until the point of injection, while also isolating flows of one or more diluents (e.g., the exhaust gas 66, steam, nitrogen, or another inert gas) until the point of injection. In other embodiments, each diffusion fuel nozzle 164 may isolate flows of the oxidant 68 and the fuel 70 until the point of injection, while partially mixing one or more diluents (e.g., the exhaust gas 66, steam, nitrogen, or

15 another inert gas) with the oxidant 68 and/or the fuel 70 prior to the point of injection. In addition, one or more diluents (e.g., the exhaust gas 66, steam, nitrogen, or another inert gas) may be injected into the combustor (e.g., into the hot products of combustion) either at or downstream from the combustion zone, thereby helping to reduce the temperature of the hot products of combustion and reduce emissions of

20 NO_x (e.g., NO and NO₂). Regardless of the type of fuel nozzle 164, the SEGR gas turbine system 52 may be controlled to provide substantially stoichiometric combustion of the oxidant 68 and fuel 70.

In diffusion combustion embodiments using the diffusion fuel nozzles 164, the fuel 70 and oxidant 68 generally do not mix upstream from the diffusion flame, but

25 rather the fuel 70 and oxidant 68 mix and react directly at the flame surface and/or the flame surface exists at the location of mixing between the fuel 70 and oxidant 68. In particular, the fuel 70 and oxidant 68 separately approach the flame surface (or diffusion boundary/interface), and then diffuse (e.g., via molecular and viscous diffusion) along the flame surface (or diffusion boundary/interface) to generate the

30 diffusion flame. It is noteworthy that the fuel 70 and oxidant 68 may be at a substantially stoichiometric ratio along this flame surface (or diffusion boundary/interface), which may result in a greater flame temperature (e.g., a peak

flame temperature) along this flame surface. The stoichiometric fuel/oxidant ratio generally results in a greater flame temperature (e.g., a peak flame temperature), as compared with a fuel-lean or fuel-rich fuel/oxidant ratio. As a result, the diffusion flame may be substantially more stable than a premix flame, because the diffusion of fuel 70 and oxidant 68 helps to maintain a stoichiometric ratio (and greater temperature) along the flame surface. Although greater flame temperatures can also lead to greater exhaust emissions, such as NO_x emissions, the disclosed embodiments use one or more diluents to help control the temperature and emissions while still avoiding any premixing of the fuel 70 and oxidant 68. For example, the disclosed 5 10 15 20 25 30

embodiments may introduce one or more diluents separate from the fuel 70 and oxidant 68 (e.g., after the point of combustion and/or downstream from the diffusion flame), thereby helping to reduce the temperature and reduce the emissions (e.g., NO_x emissions) produced by the diffusion flame.

In operation, as illustrated, the compressor section 152 receives and compresses the exhaust gas 66 from the EG processing system 54, and outputs a compressed exhaust gas 170 to each of the combustors 160 in the combustor section 154. Upon combustion of the fuel 60, oxidant 68, and exhaust gas 170 within each combustor 160, additional exhaust gas or products of combustion 172 (i.e., combustion gas) is routed into the turbine section 156. Similar to the compressor section 152, the turbine section 156 includes one or more turbines or turbine stages 174, which may include a series of rotary turbine blades. These turbine blades are then driven by the products of combustion 172 generated in the combustor section 154, thereby driving rotation of a shaft 176 coupled to the machinery 106. Again, the machinery 106 may include a variety of equipment coupled to either end of the SEGR gas turbine system 52, such as machinery 106, 178 coupled to the turbine section 156 and/or machinery 106, 180 coupled to the compressor section 152. In certain embodiments, the machinery 106, 178, 180 may include one or more electrical generators, oxidant compressors for the oxidant 68, fuel pumps for the fuel 70, gear boxes, or additional drives (e.g. steam turbine 104, electrical motor, etc.) coupled to the SEGR gas turbine system 52. Non-limiting examples are discussed in further detail below with reference to TABLE 1. As illustrated, the turbine section 156 outputs the exhaust gas 60 to recirculate along the exhaust recirculation path 110 from an exhaust outlet 182 of the turbine section 156 to

an exhaust inlet 184 into the compressor section 152. Along the exhaust recirculation path 110, the exhaust gas 60 passes through the EG processing system 54 (e.g., the HRSG 56 and/or the EGR system 58) as discussed in detail above.

Again, each combustor 160 in the combustor section 154 receives, mixes, and stoichiometrically combusts the compressed exhaust gas 170, the oxidant 68, and the fuel 70 to produce the additional exhaust gas or products of combustion 172 to drive the turbine section 156. In certain embodiments, the oxidant 68 is compressed by an oxidant compression system 186, such as a main oxidant compression (MOC) system (e.g., a main air compression (MAC) system) having one or more oxidant compressors (MOCs). The oxidant compression system 186 includes an oxidant compressor 188 coupled to a drive 190. For example, the drive 190 may include an electric motor, a combustion engine, or any combination thereof. In certain embodiments, the drive 190 may be a turbine engine, such as the gas turbine engine 150. Accordingly, the oxidant compression system 186 may be an integral part of the machinery 106. In other words, the compressor 188 may be directly or indirectly driven by the mechanical power 72 supplied by the shaft 176 of the gas turbine engine 150. In such an embodiment, the drive 190 may be excluded, because the compressor 188 relies on the power output from the turbine engine 150. However, in certain embodiments employing more than one oxidant compressor is employed, a first oxidant compressor (e.g., a low pressure (LP) oxidant compressor) may be driven by the drive 190 while the shaft 176 drives a second oxidant compressor (e.g., a high pressure (HP) oxidant compressor), or vice versa. For example, in another embodiment, the HP MOC is driven by the drive 190 and the LP oxidant compressor is driven by the shaft 176. In the illustrated embodiment, the oxidant compression system 186 is separate from the machinery 106. In each of these embodiments, the compression system 186 compresses and supplies the oxidant 68 to the fuel nozzles 164 and the combustors 160. Accordingly, some or all of the machinery 106, 178, 180 may be configured to increase the operational efficiency of the compression system 186 (e.g., the compressor 188 and/or additional compressors).

The variety of components of the machinery 106, indicated by element numbers 106A, 106B, 106C, 106D, 106E, and 106F, may be disposed along the line of the shaft 176 and/or parallel to the line of the shaft 176 in one or more series

arrangements, parallel arrangements, or any combination of series and parallel arrangements. For example, the machinery 106, 178, 180 (e.g., 106A through 106F) may include any series and/or parallel arrangement, in any order, of: one or more gearboxes (e.g., parallel shaft, epicyclic gearboxes), one or more compressors (e.g., oxidant compressors, booster compressors such as EG booster compressors), one or more power generation units (e.g., electrical generators), one or more drives (e.g., steam turbine engines, electrical motors), heat exchange units (e.g., direct or indirect heat exchangers), clutches, or any combination thereof. The compressors may include axial compressors, radial or centrifugal compressors, or any combination thereof, each having one or more compression stages. Regarding the heat exchangers, direct heat exchangers may include spray coolers (e.g., spray intercoolers), which inject a liquid spray into a gas flow (e.g., oxidant flow) for direct cooling of the gas flow. Indirect heat exchangers may include at least one wall (e.g., a shell and tube heat exchanger) separating first and second flows, such as a fluid flow (e.g., oxidant flow) separated from a coolant flow (e.g., water, air, refrigerant, or any other liquid or gas coolant), wherein the coolant flow transfers heat from the fluid flow without any direct contact. Examples of indirect heat exchangers include intercooler heat exchangers and heat recovery units, such as heat recovery steam generators. The heat exchangers also may include heaters. As discussed in further detail below, each of these machinery components may be used in various combinations as indicated by the non-limiting examples set forth in TABLE 1.

Generally, the machinery 106, 178, 180 may be configured to increase the efficiency of the compression system 186 by, for example, adjusting operational speeds of one or more oxidant compressors in the system 186, facilitating compression of the oxidant 68 through cooling, and/or extraction of surplus power. The disclosed embodiments are intended to include any and all permutations of the foregoing components in the machinery 106, 178, 180 in series and parallel arrangements, wherein one, more than one, all, or none of the components derive power from the shaft 176. As illustrated below, TABLE 1 depicts some non-limiting examples of arrangements of the machinery 106, 178, 180 disposed proximate and/or coupled to the compressor and turbine sections 152, 156.

106A	106B	106C	106D	106E	106F
MOC	GEN				
MOC	GBX	GEN			
LP MOC	HP MOC	GEN			
HP MOC	GBX	LP MOC	GEN		
MOC MOC	GBX	GEN			
HP MOC	GBX	GEN	LP MOC		
MOC MOC	GBX GBX	GEN DRV			
DRV	GBX	LP MOC	HP MOC	GBX	GEN
DRV	GBX	HP MOC	LP MOC	GEN	
HP MOC	GBX CLR	LP MOC	GEN		
HP MOC	GBX CLR	LP MOC	GBX	GEN	
HP MOC	GBX HTR STGN	LP MOC	GEN		
MOC	GEN	DRV			
MOC	DRV	GEN			
DRV	MOC	GEN			
DRV	CLU	MOC	GEN		
DRV	CLU	MOC	GBX	GEN	

TABLE 1

As illustrated above in TABLE 1, a cooling unit is represented as CLR, a clutch is represented as CLU, a drive is represented by DRV, a gearbox is represented as GBX, a generator is represented by GEN, a heating unit is represented by HTR, a main oxidant compressor unit is represented by MOC, with low pressure and high pressure variants being represented as LP MOC and HP MOC, respectively, and a steam generator unit is represented as STGN. Although TABLE 1 illustrates the machinery

106, 178, 180 in sequence toward the compressor section 152 or the turbine section 156, TABLE 1 is also intended to cover the reverse sequence of the machinery 106, 178, 180. In TABLE 1, any cell including two or more components is intended to cover a parallel arrangement of the components. TABLE 1 is not intended to exclude any non-illustrated permutations of the machinery 106, 178, 180. These components of the machinery 106, 178, 180 may enable feedback control of temperature, pressure, and flow rate of the oxidant 68 sent to the gas turbine engine 150. As discussed in further detail below, the oxidant 68 and the fuel 70 may be supplied to the gas turbine engine 150 at locations specifically selected to facilitate isolation and extraction of the compressed exhaust gas 170 without any oxidant 68 or fuel 70 degrading the quality of the exhaust gas 170.

The EG supply system 78, as illustrated in FIG. 3, is disposed between the gas turbine engine 150 and the target systems (e.g., the hydrocarbon production system 12 and the other systems 84). In particular, the EG supply system 78, e.g., the EG extraction system (EGES) 80, may be coupled to the gas turbine engine 150 at one or more extraction points 76 along the compressor section 152, the combustor section 154, and/or the turbine section 156. For example, the extraction points 76 may be located between adjacent compressor stages, such as 2, 3, 4, 5, 6, 7, 8, 9, or 10 interstage extraction points 76 between compressor stages. Each of these interstage extraction points 76 provides a different temperature and pressure of the extracted exhaust gas 42. Similarly, the extraction points 76 may be located between adjacent turbine stages, such as 2, 3, 4, 5, 6, 7, 8, 9, or 10 interstage extraction points 76 between turbine stages. Each of these interstage extraction points 76 provides a different temperature and pressure of the extracted exhaust gas 42. By further example, the extraction points 76 may be located at a multitude of locations throughout the combustor section 154, which may provide different temperatures, pressures, flow rates, and gas compositions. Each of these extraction points 76 may include an EG extraction conduit, one or more valves, sensors, and controls, which may be used to selectively control the flow of the extracted exhaust gas 42 to the EG supply system 78.

The extracted exhaust gas 42, which is distributed by the EG supply system 78, has a controlled composition suitable for the target systems (e.g., the hydrocarbon

production system 12 and the other systems 84). For example, at each of these extraction points 76, the exhaust gas 170 may be substantially isolated from injection points (or flows) of the oxidant 68 and the fuel 70. In other words, the EG supply system 78 may be specifically designed to extract the exhaust gas 170 from the gas turbine engine 150 without any added oxidant 68 or fuel 70. Furthermore, in view of the stoichiometric combustion in each of the combustors 160, the extracted exhaust gas 42 may be substantially free of oxygen and fuel. The EG supply system 78 may route the extracted exhaust gas 42 directly or indirectly to the hydrocarbon production system 12 and/or other systems 84 for use in various processes, such as enhanced oil recovery, carbon sequestration, storage, or transport to an offsite location. However, in certain embodiments, the EG supply system 78 includes the EG treatment system (EGTS) 82 for further treatment of the exhaust gas 42, prior to use with the target systems. For example, the EG treatment system 82 may purify and/or separate the exhaust gas 42 into one or more streams 95, such as the CO₂ rich, N₂ lean stream 96, the intermediate concentration CO₂, N₂ stream 97, and the CO₂ lean, N₂ rich stream 98. These treated exhaust gas streams 95 may be used individually, or in any combination, with the hydrocarbon production system 12 and the other systems 84 (e.g., the pipeline 86, the storage tank 88, and the carbon sequestration system 90).

Similar to the exhaust gas treatments performed in the EG supply system 78, the EG processing system 54 may include a plurality of exhaust gas (EG) treatment components 192, such as indicated by element numbers 194, 196, 198, 200, 202, 204, 206, 208, and 210. These EG treatment components 192 (e.g., 194 through 210) may be disposed along the exhaust recirculation path 110 in one or more series arrangements, parallel arrangements, or any combination of series and parallel arrangements. For example, the EG treatment components 192 (e.g., 194 through 210) may include any series and/or parallel arrangement, in any order, of: one or more heat exchangers (e.g., heat recovery units such as heat recovery steam generators, condensers, coolers, or heaters), catalyst systems (e.g., oxidation catalyst systems), particulate and/or water removal systems (e.g., inertial separators, coalescing filters, water impermeable filters, and other filters), chemical injection systems, solvent based treatment systems (e.g., absorbers, flash tanks, etc.), carbon capture systems, gas separation systems, gas purification systems, and/or a solvent based treatment system,

or any combination thereof. In certain embodiments, the catalyst systems may include an oxidation catalyst, a carbon monoxide reduction catalyst, a nitrogen oxides reduction catalyst, an aluminum oxide, a zirconium oxide, a silicone oxide, a titanium oxide, a platinum oxide, a palladium oxide, a cobalt oxide, or a mixed metal oxide, or a combination thereof. The disclosed embodiments are intended to include any and all permutations of the foregoing components 192 in series and parallel arrangements. As illustrated below, TABLE 2 depicts some non-limiting examples of arrangements of the components 192 along the exhaust recirculation path 110.

194	196	198	200	202	204	206	208	210
CU	HRU	BB	MRU	PRU				
CU	HRU	HRU	BB	MRU	PRU	DIL		
CU	HRSG	HRSG	BB	MRU	PRU			
OCU	HRU	OCU	HRU	OCU	BB	MRU	PRU	
HRU CU	HRU CU	BB	MRU	PRU				
HRSG OCU	HRSG OCU	BB	MRU	PRU	DIL			
OCU	HRSG OCU	OCU	HRSG OCU	OCU	BB	MRU	PRU	DIL
OCU	HRSG ST	HRSG ST	BB	COND	INER	WFIL	CFIL	DIL
OCU HRSG ST	OCU HRSG ST	BB	COND	INER	FIL	DIL		
OCU	HRSG ST	HRSG ST	OCU	BB	MRU HE COND	MRU WFIL	PRU INER	PRU FIL CFIL
CU	HRU COND	HRU COND	HRU COND	BB	MRU HE COND WFIL	PRU INER	PRU FIL CFIL	DIL

TABLE 2

As illustrated above in TABLE 2, a catalyst unit is represented by CU, an oxidation catalyst unit is represented by OCU, a booster blower is represented by BB, a heat exchanger is represented by HX, a heat recovery unit is represented by HRU, a heat recovery steam generator is represented by HRSG, a condenser is represented by COND, a steam turbine is represented by ST, a particulate removal unit is represented by PRU, a moisture removal unit is represented by MRU, a filter is represented by FIL, a coalescing filter is represented by CFIL, a water impermeable filter is represented by WFIL, an inertial separator is represented by INER, and a diluent supply system (e.g., steam, nitrogen, or other inert gas) is represented by DIL. Although TABLE 2 illustrates the components 192 in sequence from the exhaust outlet 182 of the turbine section 156 toward the exhaust inlet 184 of the compressor section 152, TABLE 2 is also intended to cover the reverse sequence of the illustrated components 192. In TABLE 2, any cell including two or more components is intended to cover an integrated unit with the components, a parallel arrangement of the components, or any combination thereof. Furthermore, in context of TABLE 2, the HRU, the HRSG, and the COND are examples of the HE; the HRSG is an example of the HRU; the COND, WFIL, and CFIL are examples of the WRU; the INER, FIL, WFIL, and CFIL are examples of the PRU; and the WFIL and CFIL are examples of the FIL. Again, TABLE 2 is not intended to exclude any non-illustrated permutations of the components 192. In certain embodiments, the illustrated components 192 (e.g., 194 through 210) may be partially or completely integrated within the HRSG 56, the EGR system 58, or any combination thereof. These EG treatment components 192 may enable feedback control of temperature, pressure, flow rate, and gas composition, while also removing moisture and particulates from the exhaust gas 60. Furthermore, the treated exhaust gas 60 may be extracted at one or more extraction points 76 for use in the EG supply system 78 and/or recirculated to the exhaust inlet 184 of the compressor section 152.

As the treated, recirculated exhaust gas 66 passes through the compressor section 152, the SEGR gas turbine system 52 may bleed off a portion of the compressed exhaust gas along one or more lines 212 (e.g., bleed conduits or bypass conduits). Each line 212 may route the exhaust gas into one or more heat exchangers 214 (e.g., cooling units), thereby cooling the exhaust gas for recirculation back into the

SEGR gas turbine system 52. For example, after passing through the heat exchanger 214, a portion of the cooled exhaust gas may be routed to the turbine section 156 along line 212 for cooling and/or sealing of the turbine casing, turbine shrouds, bearings, and other components. In such an embodiment, the SEGR gas turbine system 52 does not route any oxidant 68 (or other potential contaminants) through the turbine section 156 for cooling and/or sealing purposes, and thus any leakage of the cooled exhaust gas will not contaminate the hot products of combustion (e.g., working exhaust gas) flowing through and driving the turbine stages of the turbine section 156. By further example, after passing through the heat exchanger 214, a portion of the cooled exhaust gas may be routed along line 216 (e.g., return conduit) to an upstream compressor stage of the compressor section 152, thereby improving the efficiency of compression by the compressor section 152. In such an embodiment, the heat exchanger 214 may be configured as an interstage cooling unit for the compressor section 152. In this manner, the cooled exhaust gas helps to increase the operational efficiency of the SEGR gas turbine system 52, while simultaneously helping to maintain the purity of the exhaust gas (e.g., substantially free of oxidant and fuel).

FIG. 4 is a flow chart of an embodiment of an operational process 220 of the system 10 illustrated in FIGS 1-3. In certain embodiments, the process 220 may be a computer implemented process, which accesses one or more instructions stored on the memory 122 and executes the instructions on the processor 120 of the controller 118 shown in FIG. 2. For example, each step in the process 220 may include instructions executable by the controller 118 of the control system 100 described with reference to FIG. 2.

The process 220 may begin by initiating a startup mode of the SEGR gas turbine system 52 of FIGS. 1-3, as indicated by block 222. For example, the startup mode may involve a gradual ramp up of the SEGR gas turbine system 52 to maintain thermal gradients, vibration, and clearance (e.g., between rotating and stationary parts) within acceptable thresholds. For example, during the startup mode 222, the process 220 may begin to supply a compressed oxidant 68 to the combustors 160 and the fuel nozzles 164 of the combustor section 154, as indicated by block 224. In certain embodiments, the compressed oxidant may include a compressed air, oxygen, oxygen-enriched air, oxygen-reduced air, oxygen-nitrogen mixtures, or any combination

thereof. For example, the oxidant 68 may be compressed by the oxidant compression system 186 illustrated in FIG. 3. The process 220 also may begin to supply fuel to the combustors 160 and the fuel nozzles 164 during the startup mode 222, as indicated by block 226. During the startup mode 222, the process 220 also may begin to supply
5 exhaust gas (as available) to the combustors 160 and the fuel nozzles 164, as indicated by block 228. For example, the fuel nozzles 164 may produce one or more diffusion flames, premix flames, or a combination of diffusion and premix flames. During the startup mode 222, the exhaust gas 60 being generated by the gas turbine engine 156 may be insufficient or unstable in quantity and/or quality. Accordingly, during the
10 startup mode, the process 220 may supply the exhaust gas 66 from one or more storage units (e.g., storage tank 88), the pipeline 86, other SEGR gas turbine systems 52, or other exhaust gas sources.

The process 220 may then combust a mixture of the compressed oxidant, fuel, and exhaust gas in the combustors 160 to produce hot combustion gas 172, as
15 indicated by block 230. In particular, the process 220 may be controlled by the control system 100 of FIG. 2 to facilitate stoichiometric combustion (e.g., stoichiometric diffusion combustion, premix combustion, or both) of the mixture in the combustors 160 of the combustor section 154. However, during the startup mode 222, it may be particularly difficult to maintain stoichiometric combustion of the mixture (and thus
20 low levels of oxidant and unburnt fuel may be present in the hot combustion gas 172). As a result, in the startup mode 222, the hot combustion gas 172 may have greater amounts of residual oxidant 68 and/or fuel 70 than during a steady state mode as discussed in further detail below. For this reason, the process 220 may execute one or more control instructions to reduce or eliminate the residual oxidant 68 and/or fuel 70
25 in the hot combustion gas 172 during the startup mode.

The process 220 then drives the turbine section 156 with the hot combustion gas 172, as indicated by block 232. For example, the hot combustion gas 172 may drive one or more turbine stages 174 disposed within the turbine section 156. Downstream of the turbine section 156, the process 220 may treat the exhaust gas 60
30 from the final turbine stage 174, as indicated by block 234. For example, the exhaust gas treatment 234 may include filtration, catalytic reaction of any residual oxidant 68 and/or fuel 70, chemical treatment, heat recovery with the HRSG 56, and so forth. The

process 220 may also recirculate at least some of the exhaust gas 60 back to the compressor section 152 of the SEGR gas turbine system 52, as indicated by block 236. For example, the exhaust gas recirculation 236 may involve passage through the exhaust recirculation path 110 having the EG processing system 54 as illustrated in
5 FIGS. 1-3.

In turn, the recirculated exhaust gas 66 may be compressed in the compressor section 152, as indicated by block 238. For example, the SEGR gas turbine system 52 may sequentially compress the recirculated exhaust gas 66 in one or more compressor stages 158 of the compressor section 152. Subsequently, the compressed exhaust gas
10 170 may be supplied to the combustors 160 and fuel nozzles 164, as indicated by block 228. Steps 230, 232, 234, 236, and 238 may then repeat, until the process 220 eventually transitions to a steady state mode, as indicated by block 240. Upon the transition 240, the process 220 may continue to perform the steps 224 through 238, but may also begin to extract the exhaust gas 42 via the EG supply system 78, as indicated
15 by block 242. For example, the exhaust gas 42 may be extracted from one or more extraction points 76 along the compressor section 152, the combustor section 154, and the turbine section 156 as indicated in FIG. 3. In turn, the process 220 may supply the extracted exhaust gas 42 from the EG supply system 78 to the hydrocarbon production system 12, as indicated by block 244. The hydrocarbon production system 12 may then
20 inject the exhaust gas 42 into the earth 32 for enhanced oil recovery, as indicated by block 246. For example, the extracted exhaust gas 42 may be used by the exhaust gas injection EOR system 112 of the EOR system 18 illustrated in FIGS. 1-3.

FIG. 5 is a flow chart of a process 260 for operating the gas turbine engine 150. In the following discussion, reference is made to axial, radial, and circumferential
25 directions, which are shown in FIGS. 6-20. In a step 262, the oxidant 68 is compressed in the oxidant compressor 188. In a step 264, the exhaust gas 66 is compressed in the compressor section 152. In a step 266, the fuel 70 is routed radially into a fuel manifold within the head end portion 166 of the combustor 160. Routing the fuel 70 radially may provide more space at the head end portion 166 for other ports, as
30 described in detail below. In a step 268, the fuel 70 is routed along radial and circumferential fuel paths through the fuel manifold to at least one fuel nozzle 164. In a step 270, the oxidant 68 is routed axially through an end plate of the head end portion

166. In a step 272, the oxidant 68 is routed along an oxidant path through an oxidant chamber, fuel manifold, and into the fuel nozzle 164. In a step 274, the compressed exhaust gas 170 is taken into the head end portion 166 of the combustor 160. In a step 276, a first portion of the compressed exhaust gas 170 is routed along an exhaust gas path through a sidewall, fuel manifold, and/or end plate of the head end portion 166. In a step 278, the first portion of the compressed exhaust gas is extracted, for example in an axial direction and/or a radial direction. The extracted exhaust gas may then be transferred to the oil/gas extraction system 16, enhanced oil recovery (EOR) system 18, or another system 84. In a step 280, a second portion of the compressed exhaust gas 170 is routed through the head end portion 166 into the fuel nozzle 164. In a step 282, a mixture of the fuel 70, the oxidant 68, and the second portion of the compressed exhaust gas 170 from the fuel nozzle 164 may be combusted in the combustion portion 168. In a step 284, the turbine stages 174 may be driven with the combustion gas 172 from the combustor 160. The exhaust gas 60 from the turbine stages 174 may then be recycled to the compressor section 152 to be compressed in the second step 264. By using the process 260 to operate the gas turbine engine 150, the pressure losses in the gas turbine engine 150 may be reduced, temperature fields may be more uniform, and the durability and longevity of the gas turbine engine 150 may be increased.

FIG. 6 is a schematic diagram of an embodiment of the combustor section 154 that includes various features that are shown in detail in FIGS. 7-20. Elements in FIG. 6 in common with those shown in previous figures are labeled with the same reference numerals. The axial direction of the combustor 160 is indicated by arrow 294, the radial direction is indicated by arrow 296, and the circumferential direction is indicated by arrow 298. As shown in FIG. 6, a fuel supply system 300 supplies the fuel 70 to the combustor 160. The fuel supply system 300 may include pumps, valves, vessels, pipes, tubes, conduits, instrumentation, sensors, and other equipment or devices for transferring the fuel 70 to the combustor section 154. The fuel 70 may be injected through a radial fuel manifold, as described in detail below. In addition, the oxidant compression system 186 supplies the oxidant 68 to one or more locations of the combustor 160. Further, a flow separator 304 disposed in the head end portion 166 of the combustor 160 may separate the compressed exhaust gas 170 into two or more portions. For example, the flow separator 304 may provide a portion of the compressed

exhaust gas 170 to the exhaust extraction system 80 to provide the exhaust gas 42. In addition, the flow separator 304 may provide another portion of the compressed exhaust gas 170 to the fuel nozzles 164 to be combusted in the combustion portion 168. In other embodiments, the flow separator 304 may be used to separate one or more flows flowing through the combustor 160, such as, the exhaust gas 170, the oxidant 68, the fuel 70, and so forth. The compressed exhaust gas 170 may be substantially free of oxygen and unburnt fuel, and may result from stoichiometric combustion and exhaust gas recirculation, as discussed above. As described in detail below, the combustor 160 may include multiple points of injection and/or extraction.

5 For example, the combustor 160 may include four points of radial exhaust gas extraction, three points of axial oxidant injection (peripheral and central), the radial fuel supply to manifold, two points of axial exhaust extraction (e.g., at end plate), and so forth. In addition, the controller 118 may be used to control the exhaust extraction system 80, the oxidant compression system 186, the fuel supply system 30, or any combination thereof. The controller 118 may be used to control any of these systems in the following figures as well, but is not shown for clarity. Further details of the combustor 160 and the flow separator 304 are described below with respect to FIG. 7-20.

FIG. 7 is a partial schematic diagram of the combustor section 154, illustrating the head end portion 166 of the combustor 160. As shown in FIG. 7, the combustion section 154 has a combustion casing 320 disposed about the combustor 160. The head end portion 166 is disposed adjacent the combustion portion 168, which has a flow sleeve 322 disposed about a combustion liner 324. More generically, any one of the combustion casing 320, flow sleeve 322, or combustion liner 324 may be referred to as a sidewall 321. In certain embodiments, the flow sleeve 322 and the combustion liner 324 are coaxial with one another to define a first flow path 326 (e.g., annular passage), which may enable passage of the compressed exhaust gas 170 for cooling and for entry into the head end portion 166. In addition, the combustion casing 320 and the flow sleeve 322 may define a second flow path 328, which may also enable passage of the compressed exhaust gas 170 for cooling and for entry into the head end portion 166. A first exhaust extraction port 330 may be coupled to the combustion casing 320 (e.g., sidewall 321). As illustrated, the first exhaust extraction port 330 may be a radial port,

20
25
30

thereby conveying the compressed exhaust gas 170 from the second flow path 328 to the exhaust gas extraction system 80 radially 296. In certain embodiments, a cap 332 may be disposed between the head end portion 166 and the combustion portion 168, thereby dividing the combustor 160 into a head end chamber 331 and a combustion chamber 333.

As shown in FIG. 7, several walls are disposed about the head end chamber 331 of the head end portion 166. Specifically, a first wall 334 circumferentially 298 surrounds the fuel nozzles 164 in the head end chamber 331, a second wall 336 circumferentially 298 surrounds the first wall 334, and a third wall 338 circumferentially 298 surrounds the second wall 336. In certain embodiments, the first, second, and third walls 334, 336, and 338 may be coaxial or concentric with one another. In the illustrated embodiment, the first wall 334 generally coincides with the combustion liner 324, the second wall 336 generally coincides with the flow sleeve 322, and the third wall 338 generally coincides with the combustion casing 320. However, in other embodiments, the first, second, and third walls 334, 336, and 338 may be disposed at different locations. In the illustrated embodiment, the compressed exhaust gas 170 in the first flow path 326 continues past the cap 332 and enters a first space 340 (e.g., annular passage), between the first and second walls 334 and 336, wherein the exhaust gas 170 may then mix with the oxidant 68, as described in detail below.

In the illustrated embodiment, an oxidant port 342 (e.g., oxidant inlet) is disposed on an end plate 344 of the head end portion 166. As illustrated, the oxidant port 342 may be an axial port (e.g., an axial oxidant port), thereby conveying the oxidant 68 from the oxidant compression system 186 to the combustor 160 axially 294. As shown in FIG. 7, the oxidant port 342 is disposed along an axial face 346 of the end plate 344. The axial face 346 may be described as facing away from the head end portion 166. In addition, the oxidant port 342 is coupled to a central region 348 of the end plate 344. As shown in FIG. 7, the end plate 344 may enclose an oxidant chamber 350 that contains the oxidant 68.

A fuel manifold 352, which includes a fuel distribution plate, may be disposed between the end plate 344 and the fuel nozzles 164 in the head end portion 166. In other words, the fuel manifold 352 is disposed between the oxidant chamber 350 and

the head end chamber 331. In certain embodiments, the combustor 160 may be configured to receive several different types of fuels 70. For example, the combustor 160 may receive a liquid fuel and a gaseous fuel. In other embodiments, the combustor 160 may receive two or more liquid fuels and/or two or more gaseous fuels. In the

5 illustrated embodiment, a first fuel supply system 354 supplies a first fuel (e.g., a liquid fuel or gaseous fuel) via a first fuel port 356, a second fuel supply system 357 supplies a second fuel (e.g., a liquid fuel or gaseous fuel) via a second fuel port 358, and a third fuel supply system 360 supplies a third fuel (e.g., a liquid fuel or gaseous fuel) via a third fuel port 362. The first, second, and third fuel supply systems 354,

10 357, and 360 may be part of the fuel supply system 300. The one or more fuels 70 provided by the first, second, and third fuel supply systems 354, 357, and 360 may be routed through the fuel manifold 352 via a plurality of fuel paths 364. The fuel paths 364 may include separate and independent paths for each of the first, second, and third fuel supply systems 354, 357, and 360, thereby enabling independent control of fuel

15 flow from the fuel supply systems 354, 357, and 360. The fuel 70 may then be routed from the fuel paths 364 to the one or more fuel nozzles 164 associated with each fuel supply system 354, 357, and 360. Thus, the fuel 70 may be routed radially 296 into the fuel manifold 352 and then turn axially 294 into the fuel nozzles 164. In addition, the fuel 70 may follow circumferential 298 and/or radial 296 paths within the fuel

20 manifold 352, as described in detail below.

In addition to the fuel paths 364, the fuel manifold 352 may include one or more oxidant paths 366. Specifically, the oxidant paths 366 may convey the oxidant 68 from the oxidant chamber 350 into a second space 368 (e.g., annular passage), disposed between the second and third walls 336 and 338. The oxidant 68 may flow

25 through the second space 368 toward the cap 332 before passing through one or more openings 370 in the second wall 336. The oxidant 68 may then enter the first space 340 to mix with the compressed exhaust gas 170 to generate an oxidant-exhaust gas mixture 372. The oxidant-exhaust mixture 372 may flow toward the fuel manifold 352 before turning into the head end chamber 331 and entering the one or more fuel

30 nozzles 164. Other oxidant paths 366 may enable the oxidant 68 to combine with the oxidant-exhaust mixture 372 from the first space 340 before entering the fuel nozzles 164. In other words, the oxidant paths 366 enable the oxidant 68 to flow directly from

the oxidant chamber 350 into the head end chamber 331. As shown in FIG. 7, the fuel manifold 352 may include a centerline 374. Thus, the oxidant paths 366 may be arranged circumferentially about the centerline 374, as described in more detail below. As shown in FIG. 7, the oxidant-exhaust mixture 372 then enters the fuel nozzles 164 to be combined with the fuel 70 from the fuel manifold 352 before being combusted in the combustion chamber 333 (e.g., premix fuel nozzles). In other embodiments, the oxidant-exhaust mixture 372 is not combined with the fuel 70 until exiting the fuel nozzles 164 (e.g., diffusion fuel nozzles).

FIG. 8 is a partial cross-sectional view of a portion of the combustor 160 taken within line 8-8 of FIG. 7. As shown in FIG. 8, the fuel 70 may be routed from the fuel manifold 352 to the fuel nozzle 164 through the fuel paths 364. For example, each of the fuel paths 364 may be used to route fuel 70 from the first, second, and third fuel supply systems 354, 357, and 360. Thus, two or more fuels 70 may be routed to each fuel nozzle 164. In addition, the oxidant-exhaust mixture 372 may be routed separately from the fuel 70 and the oxidant 68 to the fuel nozzle 164. Although the central passage of the fuel nozzle 164 is shown as only flowing the fuel 70 in FIG. 8, in other embodiments, the central passage may also be used to route the oxidant 68 and/or the oxidant-exhaust mixture 372 depending on the particular operation regime of the gas turbine engine 150. The fuel nozzle 164 may deliver the oxidant 68, fuel 70, and oxidant-exhaust mixture 372 to be combusted in the combustion portion 168.

FIG. 9 is an end view of the fuel manifold 352. As shown in FIG. 9, the fuel manifold 352 may include a fuel distribution plate 353. For example, the fuel manifold 352 is coupled to the first, second, and third fuel ports 356, 358, and 362, which route first, second, and third flows of fuel 70 to the fuel nozzles 164. Specifically, a first fuel path 390 routes the fuel 70 from the first fuel port 356 to one or more fuel nozzles 164, a second fuel path 392 routes the fuel 70 from the second fuel port 358 to one or more fuel nozzles 164, and a third fuel path 394 routes the fuel 70 from the third fuel port 362 to one or more fuel nozzles 164. In certain embodiments, the first fuel path 390 may include a first circumferential path 396 and a first radial path 398, the second fuel path 392 may include a second radial path 400 and a second circumferential path 402, and the third fuel path 394 may include a third radial path 404 and a third circumferential path 406. The radial paths 398, 400, and 404 may route the fuel 70 in

the radial direction 297 and the circumferential paths 396, 402, and 406 may route the fuel in the circumferential direction 298. As illustrated, the paths 396, 398, 400, 402, 404, and 406 may be disposed about the centerline 374 of the fuel manifold 352. In certain embodiments, the arrangement of the first, second, and third fuel paths 390, 392, and 394 may be used to provide the different fuels 70 to particular fuel nozzles 164. For example, in one embodiment, one fuel path may supply the fuel 70 to all of the fuel nozzles 164. In another embodiment, a first fuel path may supply the fuel 70 to a center fuel nozzle and a second fuel path may supply the fuel 70 to outer fuel nozzles. In yet another embodiment, a first fuel path may supply the fuel 70 to the center fuel nozzle 164, a second fuel path may supply the fuel 70 to a first set of the outer fuel nozzles, and a third fuel path may supply the fuel 70 to a second set of the outer fuel nozzles 164. In addition, the fuel manifold 352 includes a plurality of oxidant paths 366 formed in the fuel manifold 352 to enable the oxidant 68 to pass through fuel manifold 352 from the oxidant chamber 350 to the head end chamber 331. As shown in FIG. 9, the oxidant paths 366 may have an oblong shape. However, in other embodiments, the shape and/or size of the oxidant paths 366 may be adjusted to achieve a desired flow rate of the oxidant 68 through the fuel manifold 352. In addition, the two or more fuels 70 routed to each fuel nozzle 164 may be the same or different from one another. For example, the two or more fuels 70 may be two different gas fuels, two different liquid fuels, a gas fuel and a liquid fuel, and so forth.

FIG. 10 is a perspective view of the end plate 344 coupled to the fuel manifold 352. As shown in FIG. 10, the oxidant 68 enters through the oxidant port 342 into the oxidant chamber 350 before continuing through the one or more oxidant paths 366 formed in the fuel manifold 352. In addition, portions of the fuel paths 364 are shown in the fuel manifold 352. The end plate 344 may be coupled to the fuel manifold via one or more boltholes 408. As shown in FIG. 10, the fuel manifold 352 maintains separation of the fuel 70 from the oxidant 68.

FIG. 11 is a schematic diagram of an embodiment of the combustor section 154. As shown in FIG. 11, the compressed exhaust gas 170 flows from the first path 326 toward the head end portion 166. Next, the second wall 336 diverts the compressed exhaust gas 170 into the second space 368 between the second and third walls 336 and 338. The first wall 334 circumferentially 298 surrounds the fuel nozzles

164 in the head end chamber 331, the second wall 336 circumferentially 298 surrounds the first wall 334, and the third wall 338 circumferentially 298 surrounds the second wall 336. In certain embodiments, the first, second, and third walls 334, 336, and 338 may be coaxial or concentric with one another. The compressed exhaust gas 170 continues to flow through the second space 368 toward the fuel manifold 352. The compressed exhaust gas 170 then flows through an exhaust gas path 420 in the fuel manifold 352 before exiting out the end plate 344. Specifically, a second exhaust extraction port 422 may be coupled to a peripheral region 424 of the end plate 344, which surrounds the central region 348 of the end plate 344. As illustrated, the second exhaust extraction port 422 may be an axial port, thereby routing the compressed exhaust gas 170 from the second exhaust extraction port 422 to the exhaust gas extraction system 80 axially 294 to be combined with the compressed exhaust gas 170 routed radially 296 from the first exhaust extraction port 330. Thus, the compressed exhaust gas 170 flowing through the second space 368 may provide additional cooling to the components of the head end portion 166.

The oxidant port 342 may also be coupled to the peripheral region 424 of the end plate 344. The oxidant 68 may be routed from the oxidant port 342 into the oxidant chamber 350 disposed between the end plate 344 and the fuel manifold 352. From the oxidant chamber 350, the oxidant 68 may flow through the plurality of oxidant paths 366 disposed in the fuel manifold 352. For example, the oxidant 68 may flow from the oxidant path 366 into a third space 426 disposed between a fourth wall 428 and the second wall 336. Specifically, the fourth wall 428 may be disposed between the first and second walls 344 and 336. In other words, the fourth wall 428 circumferentially 298 surrounds the first wall 334. In certain embodiments, the first, second, third, and fourth walls 334, 336, 338, 428 may be coaxial or concentric with one another. The oxidant 68 may continue to flow through the third space 426 toward the combustion portion 168 until the oxidant 68 reaches the one or more openings 370 formed in the fourth wall 428. The oxidant 68 may then turn to enter the first space 340 disposed between the first and fourth walls 334 and 428. As the oxidant 68 enters the first space 340, the oxidant 68 mixes with the compressed exhaust gas 170 flowing from the first passage 326 to generate the oxidant-exhaust mixture 372, which flows through the first space 340 toward the fuel manifold 352. At the fuel manifold 352, the oxidant-exhaust

mixture 372 turns radially 296 into the head end chamber 331 and then enters the fuel nozzles 164. The oxidant 68 may also flow through other oxidant paths 366 to mix with the oxidant-exhaust mixture 372. Specifically, the oxidant 68 flows directly from the oxidant chamber 350 into the head end chamber 331 through the oxidant paths 366.

5 In addition, as shown in FIG. 11, the first and second fuel supply systems 354 and 357 are coupled to the fuel manifold 352 via the first and second fuel ports 356 and 358. Although only two fuel supply systems are shown in FIG. 11, other embodiments may include 1, 2, 3, 4, 5, or more fuel supply systems. In addition, the oxidant paths 366 and the exhaust gas paths 420 are independent from the fuel path 364

10 FIG. 12 is an end view of the end cover 344 taken along line 12-12 of FIG. 11. As shown in FIG. 12, both the oxidant port 342 and the second exhaust extraction port 422 are located in the peripheral regions 424 of the end cover 344. In other words, the oxidant port 342 and the second exhaust extraction port 422 are diametrically opposite from one another. In addition, the oxidant port 342 and the second exhaust extraction port 422 may include flanges with built-in receptacles to couple to the conduits. In
15 other embodiments, the oxidant port 342 and the second exhaust extraction port 422 may be located elsewhere on the end cover 344.

FIG. 13 is a end view of the end cover 344 taken along line 13-13 of FIG. 11. As shown in FIG. 13, two oxidant ports 342 are coupled to the peripheral regions 424
20 of the end plate 344 opposite from one another. In addition, two exhaust extraction ports 422 are also coupled to the peripheral regions 424 opposite from one another. Thus, the oxidant ports 342 and the exhaust extraction ports 422 are disposed in an alternating arrangement every approximately 90 degrees. In other embodiments, the oxidant ports 342 and the second exhaust extraction ports 422 may be located
25 elsewhere on the end cover 344. For example, the two oxidant ports 342 and/or the two second exhaust extraction ports 422 may be disposed adjacent one another instead of opposite from one another. In further embodiments, additional ports may be coupled to the end cover 344.

FIG. 14 is a schematic diagram of an embodiment of the combustor section
30 154. As shown in FIG. 14, the end plate 344 includes the second exhaust extraction port 422 disposed at the peripheral region 424 and the oxidant port 342 disposed at the central region 348 (e.g., a central oxidant port). In addition, the end plate 344 includes

a third exhaust extraction port 440 disposed at the peripheral region 424. As illustrated, the third exhaust extraction port 440 may be an axial port, thereby extracting the compressed exhaust gas 170 from the combustor 160 axially 294. As shown in FIG. 14, the second and third exhaust extraction ports 422 and 440 are located at peripheral regions 424 opposite from one another. Such an arrangement of the second and third exhaust extraction ports 422 and 440 may provide a uniform distribution of the compressed exhaust gas 170 flowing through the head end portion 166 and/or capability for increased extraction of the compressed exhaust gas 170 from the combustor 160. In other respects, the embodiment of the combustor 160 shown in FIG. 14 is similar to the embodiment of the combustor 160 shown in FIG. 11.

FIG. 15 is an end view of an embodiment of the end plate 344 taken along line 15-15 of FIG. 14. As shown in FIG. 15, the second and third exhaust extraction ports 422 and 440 are disposed at the peripheral regions 424 opposite from one another. In addition, the oxidant port 342 is disposed in the central region 348 between the exhaust extraction ports 422 and 440. In other embodiments, the second and third exhaust extraction ports 422 and 440, and the oxidant port 342 may be located elsewhere on the end cover 344.

FIG. 16 is an end view of the end cover 344 taken along line 16-16 of FIG. 14. As shown in FIG. 16 the oxidant port 342 is located in the central region 348. Two second exhaust extraction ports 422 are located in the peripheral region 424 opposite from one another. In addition, two third exhaust extraction ports 440 are located in the peripheral region 424 opposite from one another. Thus, the extraction ports 42 and the extraction ports 440 are disposed in an alternating arrangement every approximately 90 degrees. In further embodiments, additional oxidant and/or exhaust extraction ports may be provided in the end plate 344 or the arrangement of the ports may be different. For example, the two second exhaust extraction ports 422 and/or the third exhaust extraction ports 440 may be disposed adjacent one another instead of opposite from one another.

FIG. 17 is a partial cross-sectional view of the end plate 344 coupled to the fuel manifold 352 taken within line 17-17 of FIG. 14. As shown in FIG. 17, the compressed exhaust gas 170 enters the second space 368, flows through the exhaust gas path 420 of the fuel manifold 352, before exiting the end plate 344 (e.g., in the axial direction

294). In addition, the oxidant 68 flows from the oxidant chamber 350 through the oxidant path 366 into the third space 426, before entering the openings 370 and mixing with the compressed exhaust gas 170 to generate the oxidant-exhaust mixture 372. In other embodiments, the second wall 336 may extend into the first space 340 and openings in the second wall 336 may be used to adjust the amount of the compressed exhaust gas 170 mixing with the oxidant 68. Specifically, the second wall 336 may couple with the combustion liner 324.

FIG. 18 is an end view of an embodiment of the fuel manifold 352 of FIG. 14. As shown in FIG. 18, the first, second and third fuel ports 356, 358, and 362 are coupled to the fuel manifold 352. In addition, the fuel manifold 352 includes a plurality of exhaust gas paths 420 and plurality of oxidant paths 366. For example, each of the plurality of exhaust gas paths 420 may be spaced apart from one another circumferentially 298 to define a ring pattern. In addition, each of the plurality of oxidant paths 366 may also be spaced apart from one another circumferentially 298 to define a ring pattern. As shown in FIG. 18, the oxidant paths 366 and/or exhaust gas paths 420 may have an oblong shape. However, in other embodiments, the shape and/or size of the oxidant paths 366 and/or exhaust gas paths 420 may be adjusted to achieve a desired flow rate of the oxidant 68 and compressed exhaust gas 170, respectively, through the fuel manifold 352. Further, the fuel manifold 352 includes a plurality of boltholes 408 for coupling the fuel manifold 352 to the end plate 344 and/or the combustor 160. Further each of the first, second, and third fuel ports 356, 358, and 362 may be coupled to radial paths 398, 400, and 404 and circumferential paths 396, 402, and 406, as described above.

FIG. 19 is a schematic diagram of an embodiment of the combustor section 154. As shown in FIG. 19, the compressed exhaust gas 170 in the second flow path 328 enters the first exhaust extraction port 330 in the radial direction 296. The compressed exhaust gas 170 in the first flow path 326 flows through the openings 370 in the second wall 336 to enter the second space 368. The compressed exhaust gas 170 in the second space 368 then exits the combustor 160 through the second exhaust extraction port 422 (e.g., in the radial direction 296) to flow to the exhaust gas extraction system 80. Thus, both the first and second exhaust extraction ports 330 and 422 are coupled to the sidewall 321. The remaining compressed exhaust gas 170 in the first space 340

flows toward the fuel manifold 352 and enters an axial swirler 450, which causes a swirling motion of the compressed exhaust gas 170 circumferentially 298 about the axis 374 of the combustor 160. The swirling compressed exhaust gas 170 then turns at the fuel manifold 352 to mix with the oxidant 68 flowing through the oxidant path 366 to generate the oxidant-exhaust mixture 372. In other words, the compressed exhaust gas 170 turns radially 296 to enter the head end chamber 331. As the mixing length available for generating the oxidant-exhaust mixture 372 in the illustrated embodiment is limited, the axial swirler 450 may help to improve the mixing of the compressed exhaust gas 170 with the oxidant 68. In certain embodiments, the axial swirler 450 may include a plurality of swirling vanes disposed circumferentially in the first space 340 about the centerline 374.

FIG. 20 is a partial cross-sectional view of the end plate 344 and the fuel manifold 352 taken within line 20-20 of FIG. 19. As shown in FIG. 20, the oxidant 68 flows through the oxidant path 366 from the oxidant chamber 350 into the head end chamber 331. The compressed exhaust gas 170 flows through the openings 370 to be removed from the combustor 160 through the second exhaust extraction port 422 (e.g., in the radial direction 296). In addition, the compressed exhaust gas 170 flows through the axial swirler 450 to be mixed with the oxidant 68 to generate the oxidant exhaust mixture 372 that then flows to the fuel nozzles 164. Specifically, the compressed exhaust gas 170 moves in the circumferential direction 298 as indicated by arrows 452.

As described above, certain embodiments of the combustor 160 may include the head end portion 166 and the combustion portion 168. In addition, the cap 332 may be disposed between the head end portion 166 and the combustion portion 168. The head end portion 166 may be disposed axially between the cap 332 and the end plate 344. In certain embodiments, the end plate 344 may include any one of the following arrangements of ports: the oxidant port 342; the oxidant port 342 and the second exhaust extraction port 422; or the oxidant port 342, the second extraction port 422, and the third extraction port 440. The oxidant port 342 may be disposed at the central region 348 or the peripheral region 424. The second and third exhaust extraction ports 422 and 440 may be disposed at the peripheral region 424. In certain embodiments, the second exhaust extraction port 422 may be coupled to the third wall 338 or sidewall 321. In certain embodiments, the exhaust gas 42 may be extracted axially 294 or

radially 296, the fuel 70 may be supplied axially 294 or radially 296, and the oxidant 68 may be supplied axially 294 or radially 296. By using configurations of the combustor 160 described above, the combustor 160 may provide more uniform distribution of the oxidant 68 and the compressed exhaust gas 170 in the combustor 160. In addition, the compressed exhaust gas 170 may be used to cool various internal components of the combustor 160, thereby increasing the longevity of the components. Further, the disclosed embodiments may provide better mixing of the oxidant 68 with the compressed exhaust gas 170.

ADDITIONAL DESCRIPTION

10 The present embodiments provide systems and methods for turbine combustors of gas turbine engines. It should be noted that any one or a combination of the features described above may be utilized in any suitable combination. Indeed, all permutations of such combinations are presently contemplated. By way of example, the following clauses are offered as further description of the present disclosure:

15 Embodiment 1. A system, comprising: a turbine combustor, comprising: a head end portion having a head end chamber, wherein the head end portion comprises an exhaust gas path, a fuel path, and an oxidant path; a combustion portion having a combustion chamber disposed downstream from the head end chamber; a cap disposed between the head end chamber and the combustion chamber; and an end plate having
20 at least one port coupled to the exhaust gas path or the oxidant path, wherein the head end chamber is disposed axially between the cap and the end plate.

Embodiment 2. The system of embodiment 1, wherein the at least one port is disposed along an axial face of the end plate.

25 Embodiment 3. The system defined in any preceding embodiment, wherein the at least one port comprises a first oxidant inlet of the oxidant path.

Embodiment 4. The system defined in any preceding embodiment, wherein the first oxidant inlet comprises an axial oxidant port.

30 Embodiment 5. The system defined in any preceding embodiment, wherein the axial oxidant port comprises a central oxidant port coupled to a central region of the end plate.

Embodiment 6. The system defined in any preceding embodiment, wherein the axial oxidant port comprises a peripheral oxidant port coupled to a peripheral

region surrounding a central region of the end plate.

Embodiment 7. The system defined in any preceding embodiment, wherein the at least one port comprises a second oxidant inlet coupled to the end plate, wherein the first oxidant inlet comprises a central oxidant port coupled to a central region of the end plate, and the second oxidant inlet comprises a peripheral oxidant port coupled to a peripheral region surrounding the central region of the end plate.

Embodiment 8. The system defined in any preceding embodiment, wherein the at least one port comprises a second oxidant inlet in the end plate, wherein the first oxidant inlet comprises a first peripheral oxidant port, the second oxidant inlet comprises a second peripheral oxidant port, and the first and second peripheral oxidant ports are coupled to a peripheral region surrounding a central region of the end plate.

Embodiment 9. The system defined in any preceding embodiment, comprising a first exhaust outlet of the exhaust gas path coupled to the head end portion.

Embodiment 10. The system defined in any preceding embodiment, wherein the at least one port comprises the first exhaust outlet, and the first exhaust outlet comprises an axial exhaust extraction port coupled to the end plate.

Embodiment 11. The system defined in any preceding embodiment, wherein the axial exhaust extraction port comprises a central exhaust extraction port coupled to a central region of the end plate.

Embodiment 12. The system defined in any preceding embodiment, wherein the axial exhaust extraction port comprises a peripheral exhaust extraction port coupled to a peripheral region surrounding a central region of the end plate.

Embodiment 13. The system defined in any preceding embodiment, wherein the at least one port comprises the first exhaust outlet and a second exhaust outlet each coupled to the end plate, wherein the first exhaust outlet comprises a first peripheral exhaust extraction port, the second exhaust outlet comprises a second peripheral exhaust extraction port, and the first and second peripheral exhaust extraction ports are coupled to a peripheral region surrounding a central region of the end plate.

Embodiment 14. The system defined in any preceding embodiment, wherein the first exhaust outlet comprises a radial exhaust extraction port coupled to a sidewall of the head end portion.

Embodiment 15. The system defined in any preceding embodiment, wherein the at least one port comprises a first oxidant inlet of the oxidant path, and the first oxidant inlet comprises an axial oxidant port.

Embodiment 16. The system defined in any preceding embodiment, wherein
5 the at least one port comprises a first oxidant inlet of the oxidant path and a first exhaust outlet of the exhaust gas path, the first oxidant inlet comprises an axial oxidant port coupled to the end plate, and the first exhaust outlet comprises an axial exhaust extraction port coupled to the end plate.

Embodiment 17. The system defined in any preceding embodiment, wherein
10 the head end portion comprises a fuel manifold having a first radial fuel inlet coupled to a first fuel path of the fuel path.

Embodiment 18. The system defined in any preceding embodiment, wherein the fuel manifold is disposed between the at least one port and the cap.

Embodiment 19. The system defined in any preceding embodiment, wherein
15 the fuel manifold comprises a fuel distribution plate disposed between the end plate and at least one fuel nozzle in the head end chamber.

Embodiment 20. The system defined in any preceding embodiment, wherein the first fuel path comprises a first radial path and a first circumferential path disposed about a centerline of the fuel manifold.

Embodiment 21. The system defined in any preceding embodiment, wherein
20 the fuel manifold comprises a second radial fuel inlet coupled to a second fuel path independent from the first fuel path.

Embodiment 22. The system defined in any preceding embodiment, wherein
25 the first fuel path comprises a first radial path and a first circumferential path disposed about a centerline of the fuel manifold, and the second fuel path comprises a second radial path and a second circumferential path disposed about the centerline of the fuel manifold.

Embodiment 23. The system defined in any preceding embodiment, wherein
30 the fuel manifold comprises a third radial fuel inlet coupled to a third fuel path, wherein the first, second, and third fuel paths are independent from one another.

Embodiment 24. The system defined in any preceding embodiment, wherein the first fuel path comprises a first radial path and a first circumferential path disposed

about a centerline of the fuel manifold, the second fuel path comprises a second radial path and a second circumferential path disposed about the centerline of the fuel manifold, and the third fuel path comprises a third radial path and a third circumferential path disposed about the centerline of the fuel manifold.

5 Embodiment 25. The system defined in any preceding embodiment, comprising a gas turbine engine having the turbine combustor, a turbine driven by combustion products from the turbine combustor, and an exhaust gas compressor driven by the turbine, wherein the exhaust gas compressor is configured to supply an exhaust gas to the turbine combustor, wherein the exhaust gas path is configured to
10 route the exhaust gas into the head end portion.

Embodiment 26. The system defined in any preceding embodiment, comprising an exhaust gas extraction system coupled to the gas turbine engine, and a hydrocarbon production system coupled to the exhaust gas extraction system.

Embodiment 27. The system defined in any preceding embodiment, wherein
15 the gas turbine engine is a stoichiometric exhaust gas recirculation (SEGR) gas turbine engine.

Embodiment 28. A system, comprising: a turbine combustor, comprising: a head end portion having a head end chamber, wherein the head end portion comprises an exhaust gas path, a fuel path, and an oxidant path; a combustion portion having a
20 combustion chamber disposed downstream from the head end chamber; a cap disposed between the head end chamber and the combustion chamber; and an end plate having a first oxidant inlet of the oxidant path, wherein the head end chamber is disposed axially between the cap and the end plate.

Embodiment 29. The system defined in any preceding embodiment, wherein
25 the first oxidant inlet is disposed along a face of the end plate facing away from the head end chamber, wherein the end plate has a first exhaust outlet of the exhaust gas path disposed along the face.

Embodiment 30. The system defined in any preceding embodiment, wherein
30 the first oxidant inlet is disposed along a face of the end plate facing away from the head end chamber, and a sidewall of the head end portion comprises a first exhaust outlet of the exhaust gas path.

Embodiment 31. The system defined in any preceding embodiment, wherein

the head end portion comprises a fuel manifold having a first radial fuel inlet coupled to a first fuel path of the fuel path, and the first fuel path comprises a first radial path and a first circumferential path disposed about a centerline of the fuel manifold.

Embodiment 32. A system, comprising: a turbine combustor, comprising: a
5 head end portion having a head end chamber, wherein the head end portion comprises an exhaust gas path, a fuel path, and an oxidant path; a combustion portion having a combustion chamber disposed downstream from the head end chamber; a cap disposed between the head end chamber and the combustion chamber; and an end plate having a first exhaust outlet of the exhaust gas path, wherein the head end chamber is disposed
10 axially between the cap and the end plate.

Embodiment 33. The system defined in any preceding embodiment, wherein the first exhaust outlet is disposed along a face of the end plate facing away from the head end chamber.

Embodiment 34. The system defined in any preceding embodiment, wherein
15 the head end portion comprises a first oxidant inlet of the oxidant path.

Embodiment 35. The system defined in any preceding embodiment, wherein the head end portion comprises a fuel manifold having a first radial fuel inlet coupled to a first fuel path of the fuel path, and the first fuel path comprises a first radial path and a first circumferential path disposed about a centerline of the fuel manifold.

Embodiment 36. A system, comprising: a turbine combustor, comprising: a
20 head end portion having a head end chamber, wherein the head end portion comprises an exhaust gas path, a fuel path, and an oxidant path; a combustion portion having a combustion chamber disposed downstream from the head end chamber; a cap disposed between the head end chamber and the combustion chamber; an end plate, wherein the
25 head end chamber is disposed axially between the cap and the end plate; and a fuel manifold disposed between the cap and the end plate, wherein the fuel manifold comprises a first radial fuel inlet coupled to a first fuel path of the fuel path, and the first fuel path comprises a first radial path and a first circumferential path disposed about a centerline of the fuel manifold.

Embodiment 37. The system defined in any preceding embodiment, wherein
30 the oxidant path extends through the fuel manifold independent from the fuel path.

Embodiment 38. The system defined in any preceding embodiment, wherein

the exhaust gas path extends through the fuel manifold independent from the fuel path.

Embodiment 39. The system defined in any preceding embodiment, wherein the end plate has at least one port coupled to the exhaust gas path or the oxidant path.

Embodiment 40. A system, comprising: a turbine combustor fuel manifold
5 configured to mount within a head end chamber of a turbine combustor, wherein the turbine combustor fuel manifold comprises a first radial fuel inlet coupled to a first fuel path, and the first fuel path comprises a first radial path and a first circumferential path disposed about a centerline of the turbine combustor fuel manifold.

Embodiment 41. The system defined in any preceding embodiment,
10 comprising an oxidant path extending through the turbine combustor fuel manifold.

Embodiment 42. The system defined in any preceding embodiment, comprising an exhaust gas path extending through the turbine combustor fuel manifold.

Embodiment 43. The system defined in any preceding embodiment, wherein
15 the turbine combustor fuel manifold comprises a second radial fuel inlet coupled to a second fuel path independent from the first fuel path, wherein the second fuel path comprises a second radial path and a second circumferential path disposed about the centerline of the turbine combustor fuel manifold.

Embodiment 44. The system defined in any preceding embodiment, wherein
20 the turbine combustor fuel manifold comprises a third radial fuel inlet coupled to a third fuel path, wherein the first, second, and third fuel paths are independent from one another, wherein the third fuel path comprises a third radial path and a third circumferential path disposed about the centerline of the turbine combustor fuel manifold.

Embodiment 45. A system, comprising: an end plate of a combustor of a
25 stoichiometric exhaust gas recirculation (SEGR) gas turbine engine, wherein the end plate comprises at least one of an axial oxidant inlet or an axial exhaust outlet.

Embodiment 46. The system defined in any preceding embodiment, comprising the axial oxidant inlet configured to receive an oxidant into the combustor.

Embodiment 47. The system defined in any preceding embodiment,
30 comprising the axial exhaust outlet configured to output an exhaust gas.

Embodiment 48. A method, comprising: routing a fuel through a head end

portion of a turbine combustor; routing an oxidant through the head end portion of the turbine combustor; routing an exhaust gas through the head end portion of the turbine combustor; and combusting a mixture of the fuel, the oxidant, and the exhaust gas in a combustion portion of the turbine combustor; wherein at least one of the oxidant or the exhaust gas passes through an end plate of the head end portion of the turbine combustor.

Embodiment 49. The method or system defined in any preceding embodiment, wherein routing the fuel comprises intaking the fuel through a first radial fuel inlet into a first fuel path within a fuel manifold disposed inside the head end portion, and the first fuel path comprises a first radial path and a first circumferential path disposed about a centerline of the fuel manifold.

Embodiment 50. The method or system defined in any preceding embodiment, wherein routing the oxidant comprises intaking the oxidant through the end plate into the head end portion.

Embodiment 51. The method or system defined in any preceding embodiment, wherein routing the exhaust gas comprises extracting the exhaust gas through the end plate away from the head end portion.

Embodiment 52. The method or system defined in any preceding embodiment, comprising: a first wall disposed about the head end chamber; a second wall disposed about the first wall to define a first space; and a third wall disposed about the second wall to define a second space, wherein the second space is configured to route an oxidant to the first space.

Embodiment 52. The method or system defined in any preceding embodiment, a first wall disposed about the head end chamber; a second wall disposed about the first wall to define a first space; a third wall disposed about the second wall to define a second space, wherein the second wall is configured to route an exhaust gas; and an axial swirler disposed in the second space, wherein the axial swirler is configured to impart a swirling motion to the exhaust gas.

Embodiment 53. The method or system defined in any preceding embodiment, wherein the turbine combustor is configured to combust a mixture of a fuel and an oxidant with an equivalence ratio of approximately 0.95 to approximately 1.05.

This written description uses examples to disclose the invention, including the

best mode, and also to enable any person skilled in the art to practice the invention, including making and using any devices or systems and performing any incorporated methods. The patentable scope of the invention is defined by the claims, and may include other examples that occur to those skilled in the art. Such other examples are
5 intended to be within the scope of the claims if they have structural elements that do not differ from the literal language of the claims, or if they include equivalent structural elements with insubstantial differences from the literal language of the claims.

CLAIMS:

1. A system, comprising:
 - a turbine combustor, comprising:
 - a head end portion having a head end chamber, wherein the
5 head end portion comprises an exhaust gas path, a fuel path, and an oxidant path;
 - a combustion portion having a combustion chamber disposed
downstream from the head end chamber;
 - a cap disposed between the head end chamber and the
combustion chamber; and
10 an end plate having at least one port coupled to the exhaust
gas path or the oxidant path, wherein the head end chamber is disposed axially
between the cap and the end plate.
2. The system of claim 1, wherein the at least one port is disposed along an
axial face of the end plate.
- 15 3. The system of claim 1, wherein the at least one port comprises a first
oxidant inlet of the oxidant path.
4. The system of claim 3, wherein the first oxidant inlet comprises an axial
oxidant port.
5. The system of claim 4, wherein the axial oxidant port comprises a central
20 oxidant port coupled to a central region of the end plate.
6. The system of claim 4, wherein the axial oxidant port comprises a
peripheral oxidant port coupled to a peripheral region surrounding a central region of
the end plate.
7. The system of claim 3, wherein the at least one port comprises a second
25 oxidant inlet coupled to the end plate, wherein the first oxidant inlet comprises a
central oxidant port coupled to a central region of the end plate, and the second oxidant
inlet comprises a peripheral oxidant port coupled to a peripheral region surrounding
the central region of the end plate.
8. The system of claim 3, wherein the at least one port comprises a second
30 oxidant inlet in the end plate, wherein the first oxidant inlet comprises a first peripheral
oxidant port, the second oxidant inlet comprises a second peripheral oxidant port, and
the first and second peripheral oxidant ports are coupled to a peripheral region

surrounding a central region of the end plate.

9. The system of claim 1, comprising a first exhaust outlet of the exhaust gas path coupled to the head end portion.

10. The system of claim 9, wherein the at least one port comprises the first exhaust outlet, and the first exhaust outlet comprises an axial exhaust extraction port coupled to the end plate.

11. The system of claim 10, wherein the axial exhaust extraction port comprises a central exhaust extraction port coupled to a central region of the end plate.

12. The system of claim 10, wherein the axial exhaust extraction port comprises a peripheral exhaust extraction port coupled to a peripheral region surrounding a central region of the end plate.

13. The system of claim 9, wherein the at least one port comprises the first exhaust outlet and a second exhaust outlet each coupled to the end plate, wherein the first exhaust outlet comprises a first peripheral exhaust extraction port, the second exhaust outlet comprises a second peripheral exhaust extraction port, and the first and second peripheral exhaust extraction ports are coupled to a peripheral region surrounding a central region of the end plate.

14. The system of claim 9, wherein the first exhaust outlet comprises a radial exhaust extraction port coupled to a sidewall of the head end portion.

15. The system of claim 14, wherein the at least one port comprises a first oxidant inlet of the oxidant path, and the first oxidant inlet comprises an axial oxidant port.

16. The system of claim 1, wherein the at least one port comprises a first oxidant inlet of the oxidant path and a first exhaust outlet of the exhaust gas path, the first oxidant inlet comprises an axial oxidant port coupled to the end plate, and the first exhaust outlet comprises an axial exhaust extraction port coupled to the end plate.

17. The system of claim 1, wherein the head end portion comprises a fuel manifold having a first radial fuel inlet coupled to a first fuel path of the fuel path.

18. The system of claim 17, wherein the fuel manifold is disposed between the at least one port and the cap.

19. The system of claim 18, wherein the fuel manifold comprises a fuel distribution plate disposed between the end plate and at least one fuel nozzle in the

head end chamber.

20. The system of claim 17, wherein the first fuel path comprises a first radial path and a first circumferential path disposed about a centerline of the fuel manifold.

21. The system of claim 17, wherein the fuel manifold comprises a second radial fuel inlet coupled to a second fuel path independent from the first fuel path.

22. The system of claim 21, wherein the first fuel path comprises a first radial path and a first circumferential path disposed about a centerline of the fuel manifold, and the second fuel path comprises a second radial path and a second circumferential path disposed about the centerline of the fuel manifold.

23. The system of claim 21, wherein the fuel manifold comprises a third radial fuel inlet coupled to a third fuel path, wherein the first, second, and third fuel paths are independent from one another.

24. The system of claim 23, wherein the first fuel path comprises a first radial path and a first circumferential path disposed about a centerline of the fuel manifold, the second fuel path comprises a second radial path and a second circumferential path disposed about the centerline of the fuel manifold, and the third fuel path comprises a third radial path and a third circumferential path disposed about the centerline of the fuel manifold.

25. The system of claim 1, comprising a gas turbine engine having the turbine combustor, a turbine driven by combustion products from the turbine combustor, and an exhaust gas compressor driven by the turbine, wherein the exhaust gas compressor is configured to supply an exhaust gas to the turbine combustor, wherein the exhaust gas path is configured to route the exhaust gas into the head end portion.

26. The system of claim 25, comprising an exhaust gas extraction system coupled to the gas turbine engine, and a hydrocarbon production system coupled to the exhaust gas extraction system.

27. The system of claim 25, wherein the gas turbine engine is a stoichiometric exhaust gas recirculation (SEGR) gas turbine engine.

28. A system, comprising:
a turbine combustor, comprising:
a head end portion having a head end chamber, wherein the head end portion comprises an exhaust gas path, a fuel path, and an oxidant path;

a combustion portion having a combustion chamber disposed downstream from the head end chamber;

a cap disposed between the head end chamber and the combustion chamber; and

5 an end plate having a first oxidant inlet of the oxidant path, wherein the head end chamber is disposed axially between the cap and the end plate.

29. The system of claim 28, wherein the first oxidant inlet is disposed along a face of the end plate facing away from the head end chamber, wherein the end plate has a first exhaust outlet of the exhaust gas path disposed along the face.

10 30. The system of claim 28, wherein the first oxidant inlet is disposed along a face of the end plate facing away from the head end chamber, and a sidewall of the head end portion comprises a first exhaust outlet of the exhaust gas path.

31. The system of claim 28, wherein the head end portion comprises a fuel manifold having a first radial fuel inlet coupled to a first fuel path of the fuel path, and
15 the first fuel path comprises a first radial path and a first circumferential path disposed about a centerline of the fuel manifold.

32. A system, comprising:

a turbine combustor, comprising:

20 a head end portion having a head end chamber, wherein the head end portion comprises an exhaust gas path, a fuel path, and an oxidant path;

a combustion portion having a combustion chamber disposed downstream from the head end chamber;

a cap disposed between the head end chamber and the combustion chamber; and

25 an end plate having a first exhaust outlet of the exhaust gas path, wherein the head end chamber is disposed axially between the cap and the end plate.

33. The system of claim 32, wherein the first exhaust outlet is disposed along a face of the end plate facing away from the head end chamber.

30 34. The system of claim 33, wherein the head end portion comprises a first oxidant inlet of the oxidant path.

35. The system of claim 32, wherein the head end portion comprises a fuel

manifold having a first radial fuel inlet coupled to a first fuel path of the fuel path, and the first fuel path comprises a first radial path and a first circumferential path disposed about a centerline of the fuel manifold.

36. A system, comprising:

5 a turbine combustor, comprising:

a head end portion having a head end chamber, wherein the head end portion comprises an exhaust gas path, a fuel path, and an oxidant path;

a combustion portion having a combustion chamber disposed downstream from the head end chamber;

10 a cap disposed between the head end chamber and the combustion chamber;

an end plate, wherein the head end chamber is disposed axially between the cap and the end plate; and

15 a fuel manifold disposed between the cap and the end plate, wherein the fuel manifold comprises a first radial fuel inlet coupled to a first fuel path of the fuel path, and the first fuel path comprises a first radial path and a first circumferential path disposed about a centerline of the fuel manifold.

37. The system of claim 36, wherein the oxidant path extends through the fuel manifold independent from the fuel path.

20 38. The system of claim 36, wherein the exhaust gas path extends through the fuel manifold independent from the fuel path.

39. The system of claim 36, wherein the end plate has at least one port coupled to the exhaust gas path or the oxidant path.

40. A system, comprising:

25 a turbine combustor fuel manifold configured to mount within a head end chamber of a turbine combustor, wherein the turbine combustor fuel manifold comprises a first radial fuel inlet coupled to a first fuel path, and the first fuel path comprises a first radial path and a first circumferential path disposed about a centerline of the turbine combustor fuel manifold.

30 41. The system of claim 40, comprising an oxidant path extending through the turbine combustor fuel manifold.

42. The system of claim 40, comprising an exhaust gas path extending

through the turbine combustor fuel manifold.

43. The system of claim 40, wherein the turbine combustor fuel manifold comprises a second radial fuel inlet coupled to a second fuel path independent from the first fuel path, wherein the second fuel path comprises a second radial path and a
5 second circumferential path disposed about the centerline of the turbine combustor fuel manifold.

44. The system of claim 43, wherein the turbine combustor fuel manifold comprises a third radial fuel inlet coupled to a third fuel path, wherein the first, second, and third fuel paths are independent from one another, wherein the third fuel path
10 comprises a third radial path and a third circumferential path disposed about the centerline of the turbine combustor fuel manifold.

45. A system, comprising:
an end plate of a combustor of a stoichiometric exhaust gas recirculation (SEGR) gas turbine engine, wherein the end plate comprises at least one of an axial
15 oxidant inlet or an axial exhaust outlet.

46. The system of claim 45, comprising the axial oxidant inlet configured to receive an oxidant into the combustor.

47. The system of claim 45, comprising the axial exhaust outlet configured to output an exhaust gas.

20 48. A method, comprising:
routing a fuel through a head end portion of a turbine combustor;
routing an oxidant through the head end portion of the turbine combustor;
routing an exhaust gas through the head end portion of the turbine combustor; and

25 combusting a mixture of the fuel, the oxidant, and the exhaust gas in a combustion portion of the turbine combustor;

wherein at least one of the oxidant or the exhaust gas passes through an end plate of the head end portion of the turbine combustor.

49. The method of claim 48, wherein routing the fuel comprises intaking the
30 fuel through a first radial fuel inlet into a first fuel path within a fuel manifold disposed inside the head end portion, and the first fuel path comprises a first radial path and a first circumferential path disposed about a centerline of the fuel manifold.

50. The method of claim 48, wherein routing the oxidant comprises intaking the oxidant through the end plate into the head end portion.

51. The method of claim 48, wherein routing the exhaust gas comprises extracting the exhaust gas through the end plate away from the head end portion.

5 52. The system of claim 1, comprising:
a first wall disposed about the head end chamber;
a second wall disposed about the first wall to define a first space; and
a third wall disposed about the second wall to define a second space,
wherein the second space is configured to route an oxidant to the first space.

10 53. The system of claim 1, comprising:
a first wall disposed about the head end chamber;
a second wall disposed about the first wall to define a first space;
a third wall disposed about the second wall to define a second space,
wherein the second wall is configured to route an exhaust gas; and
15 an axial swirler disposed in the second space, wherein the axial swirler is
configured to impart a swirling motion to the exhaust gas.

20

25

30

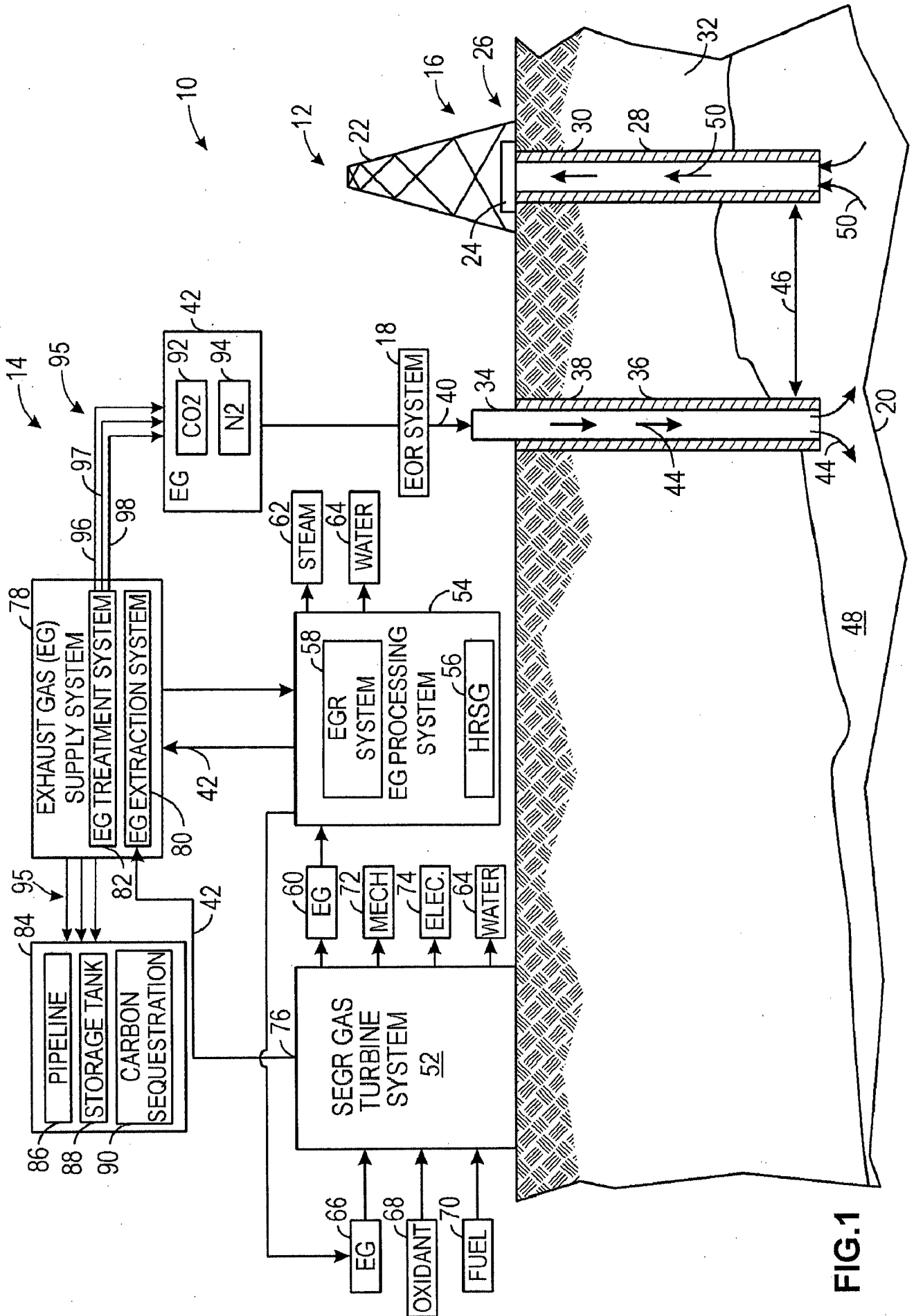

FIG.1

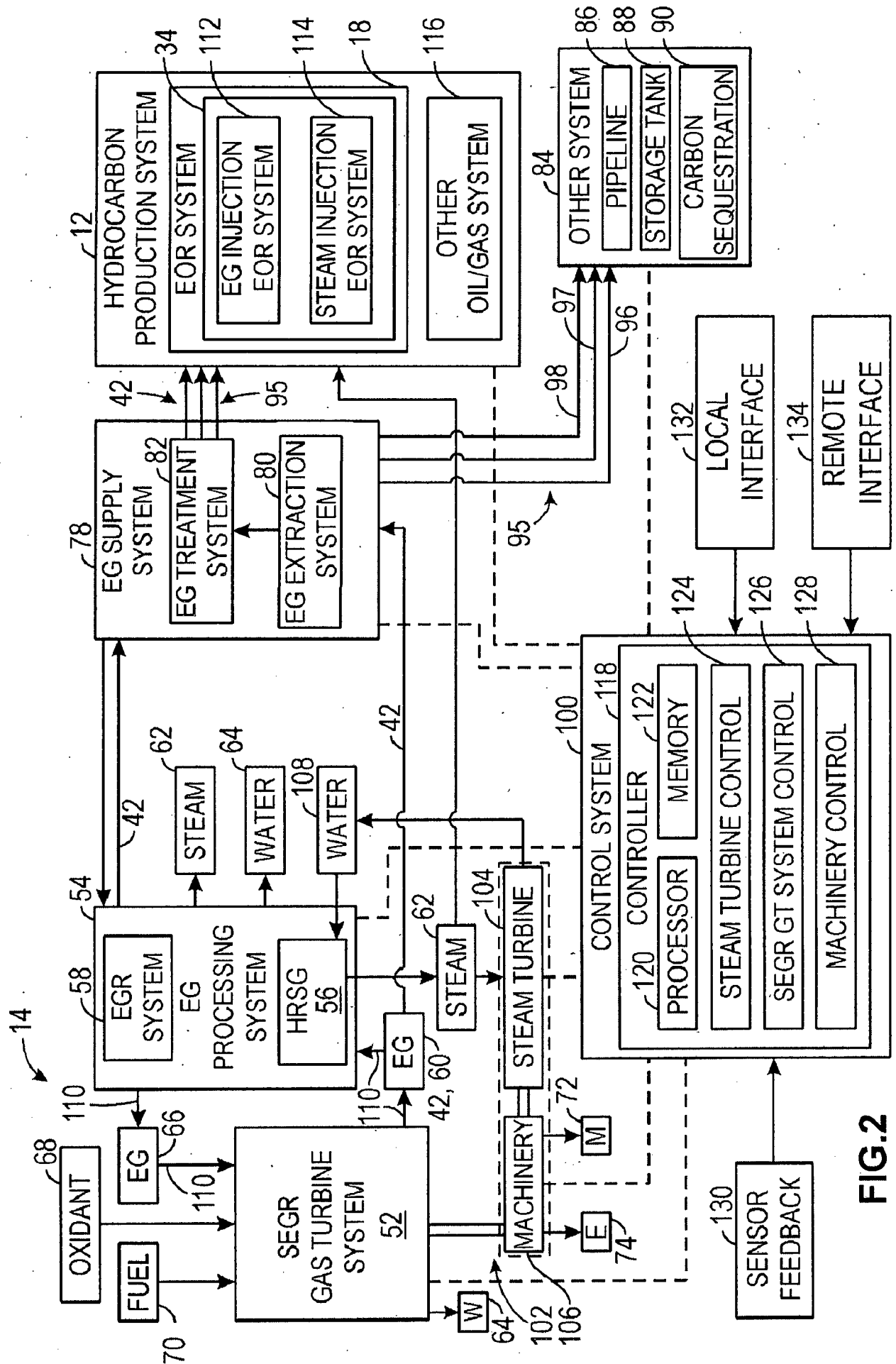

FIG.2

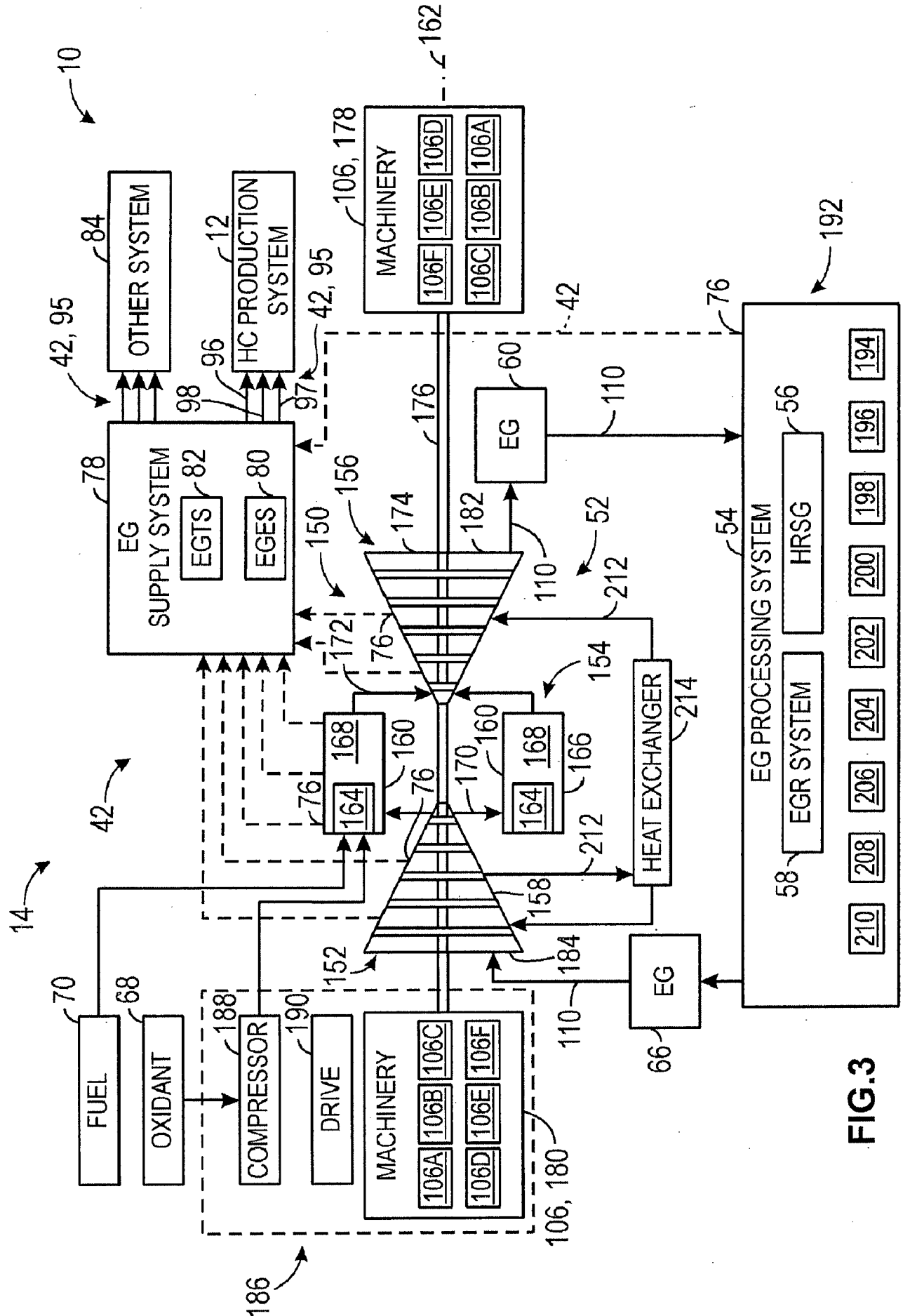

FIG.3

4/12

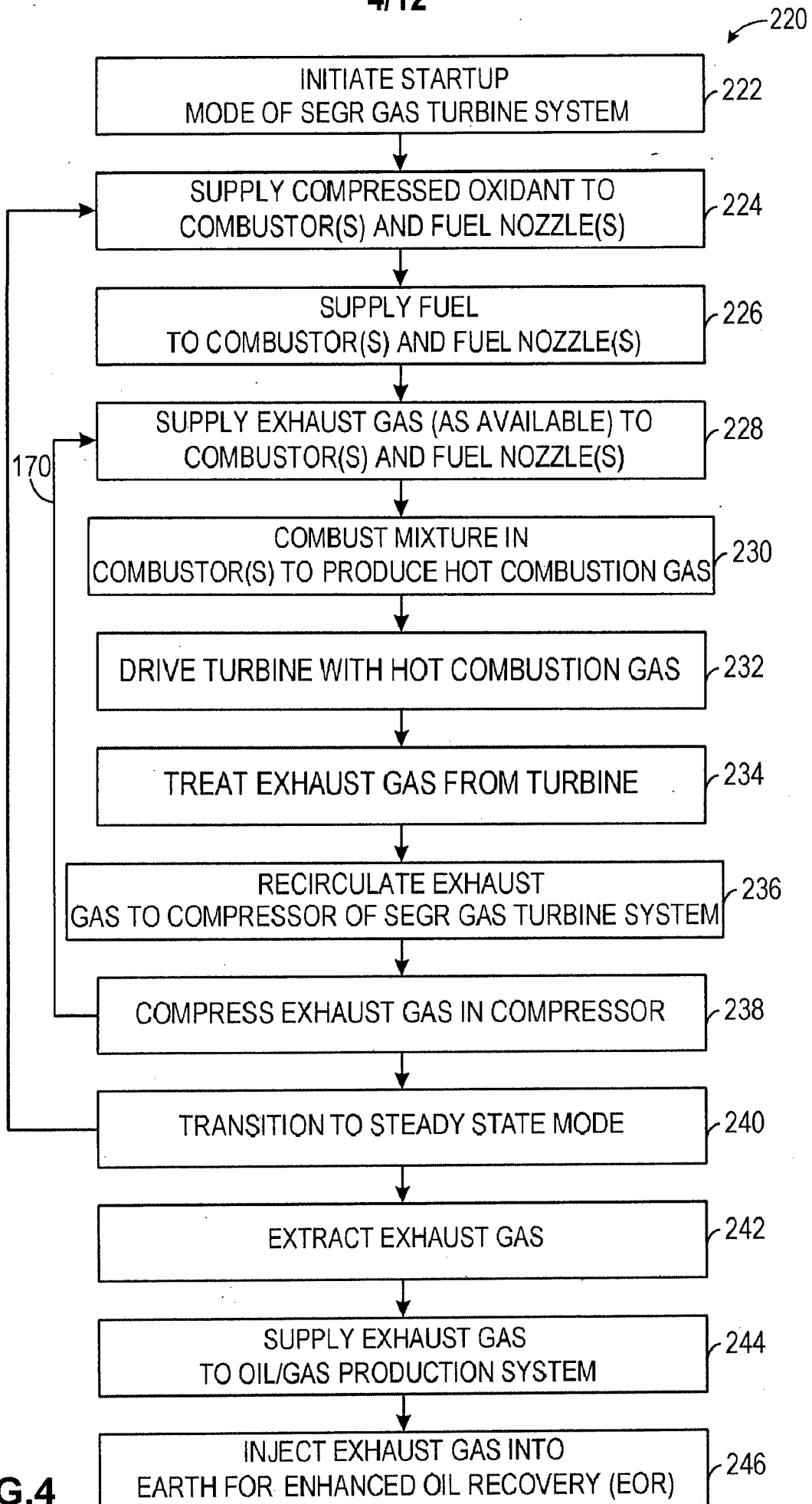

FIG.4

5/12

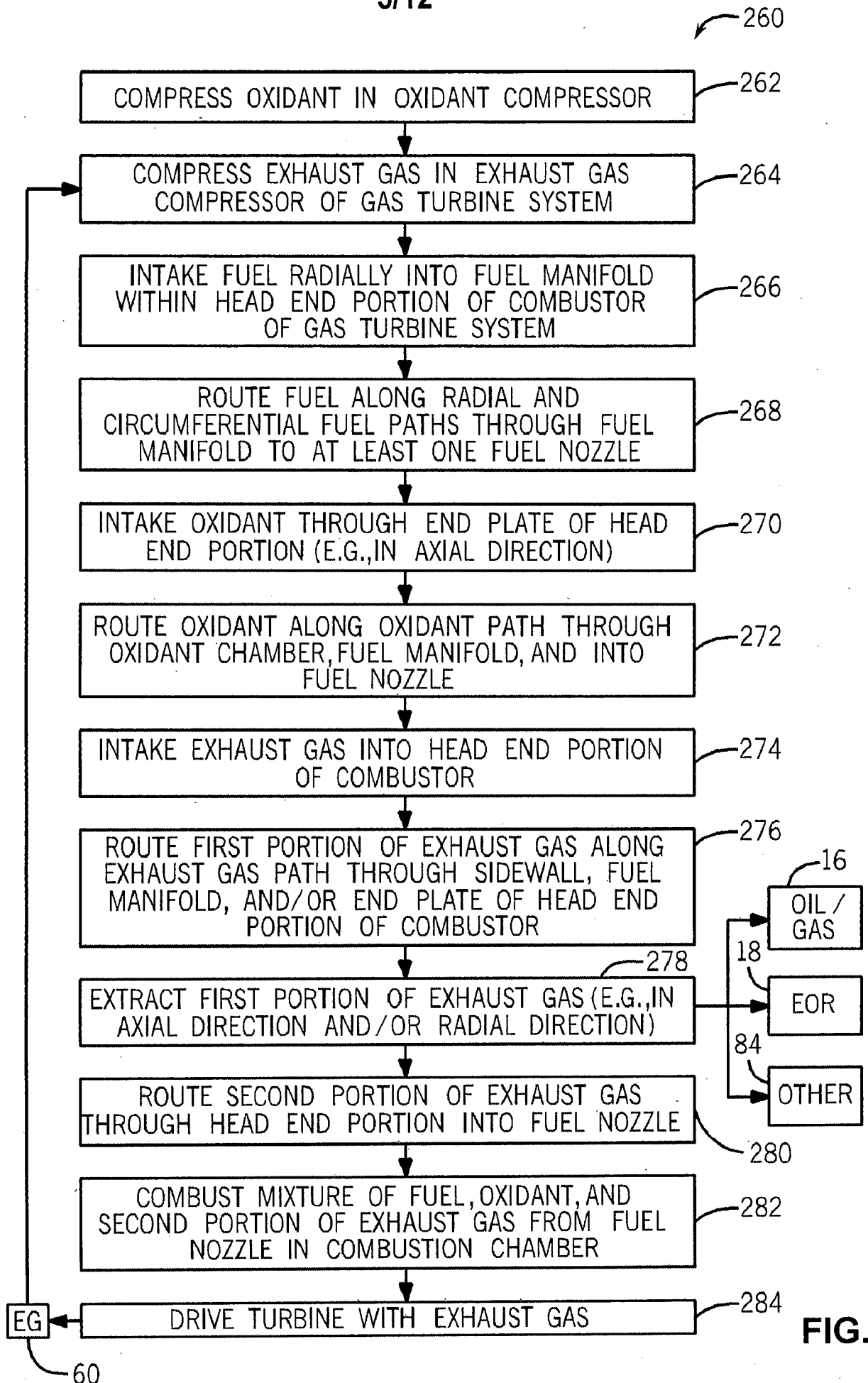

FIG.5

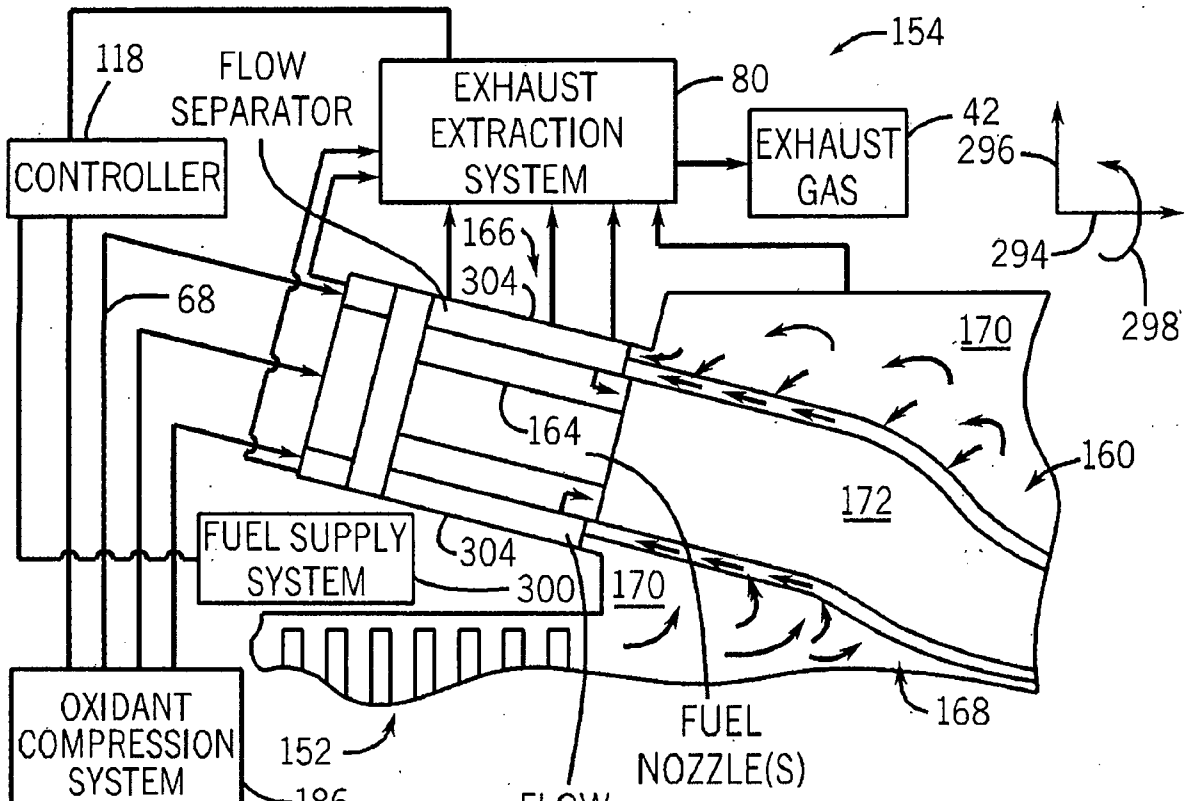

FIG. 6

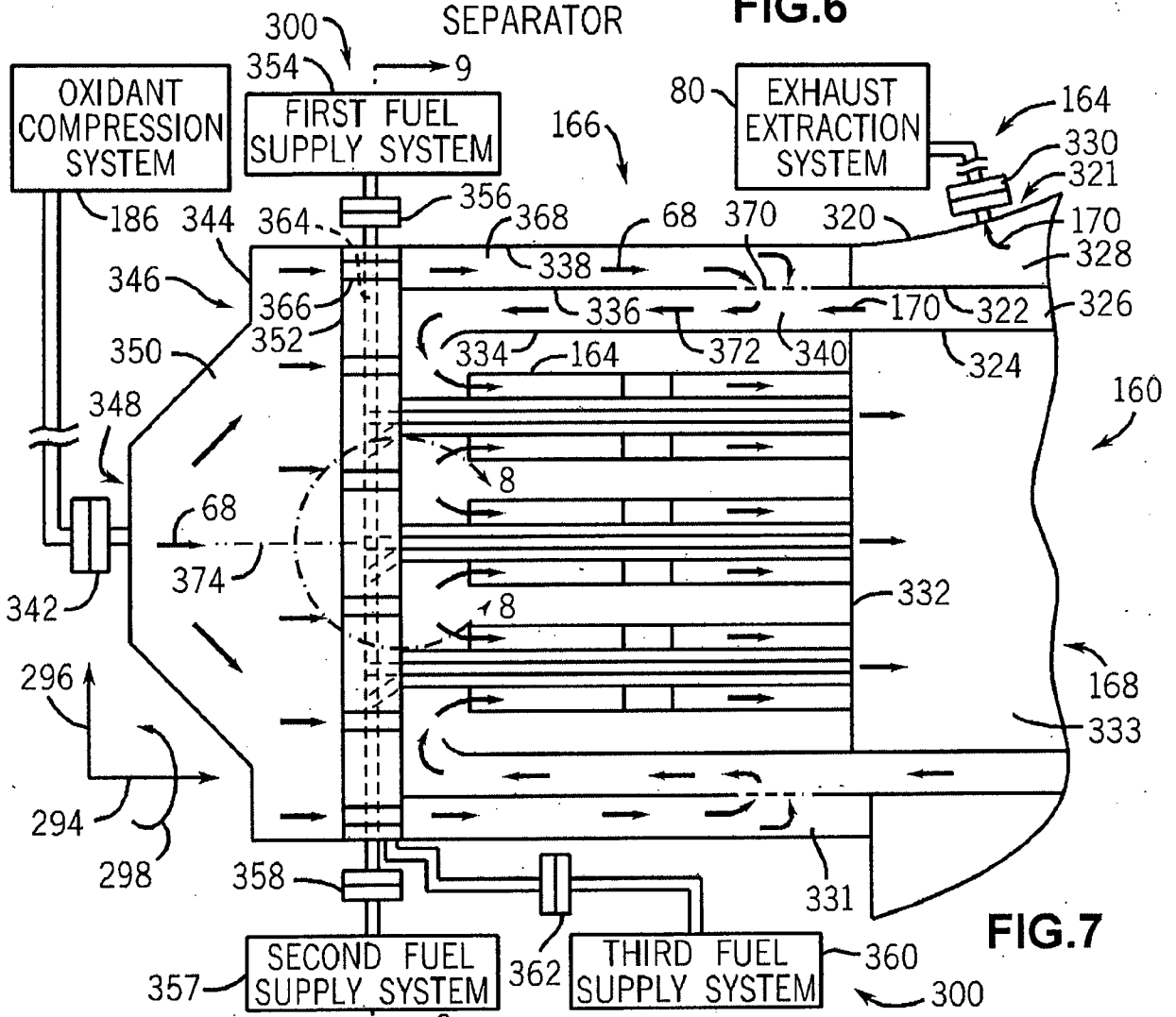

FIG. 7

FIG.8

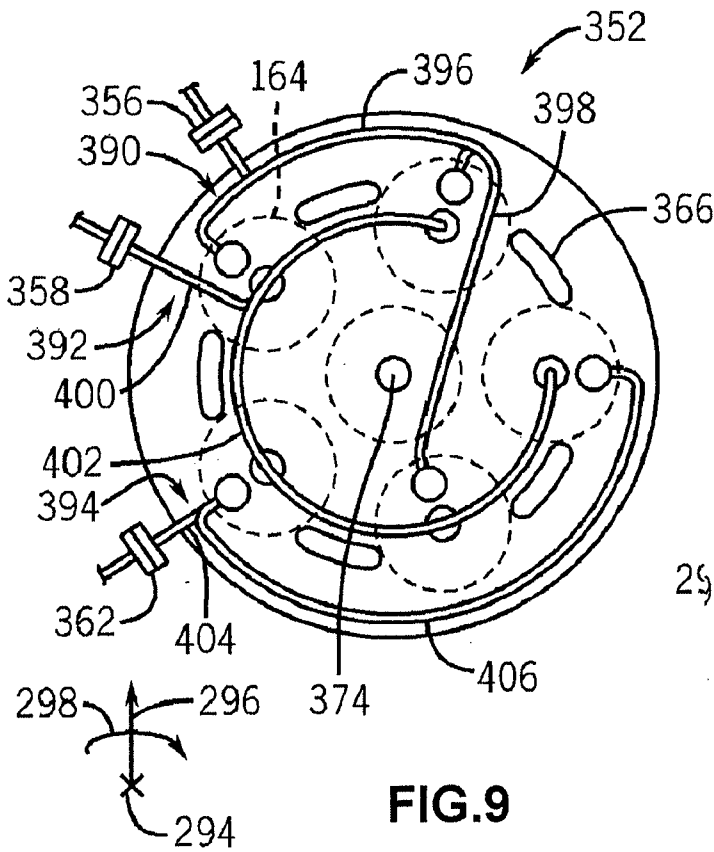
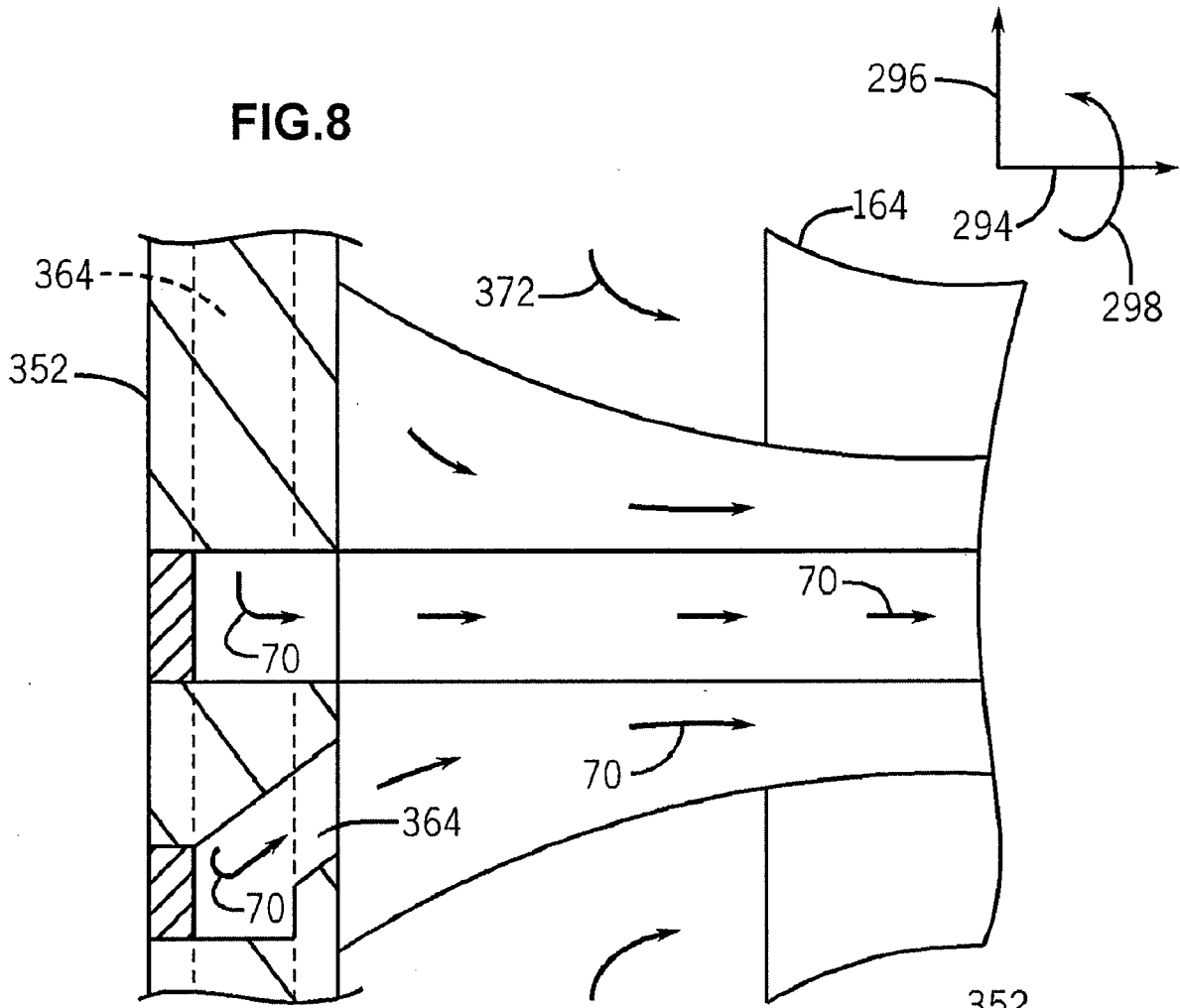

FIG.9

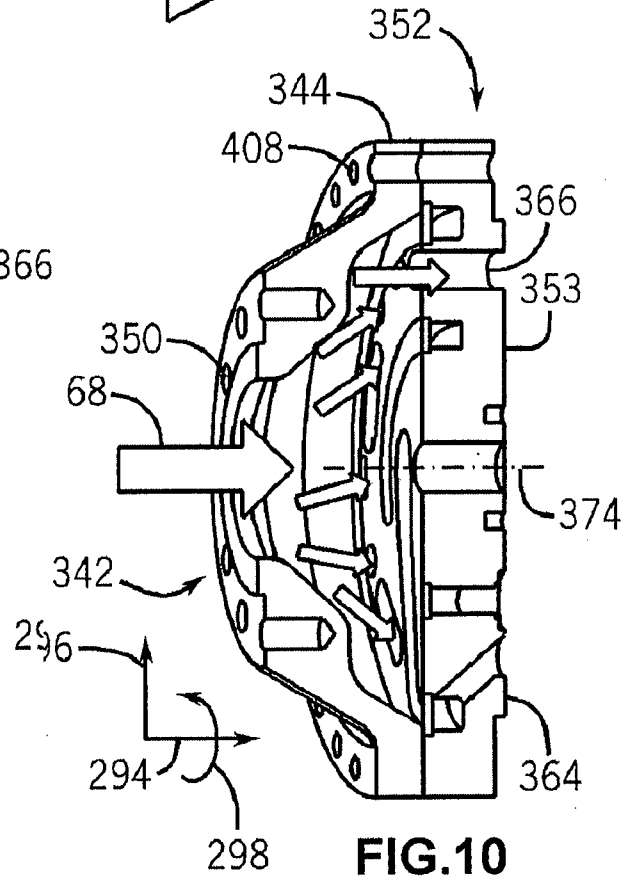

FIG.10

8/12

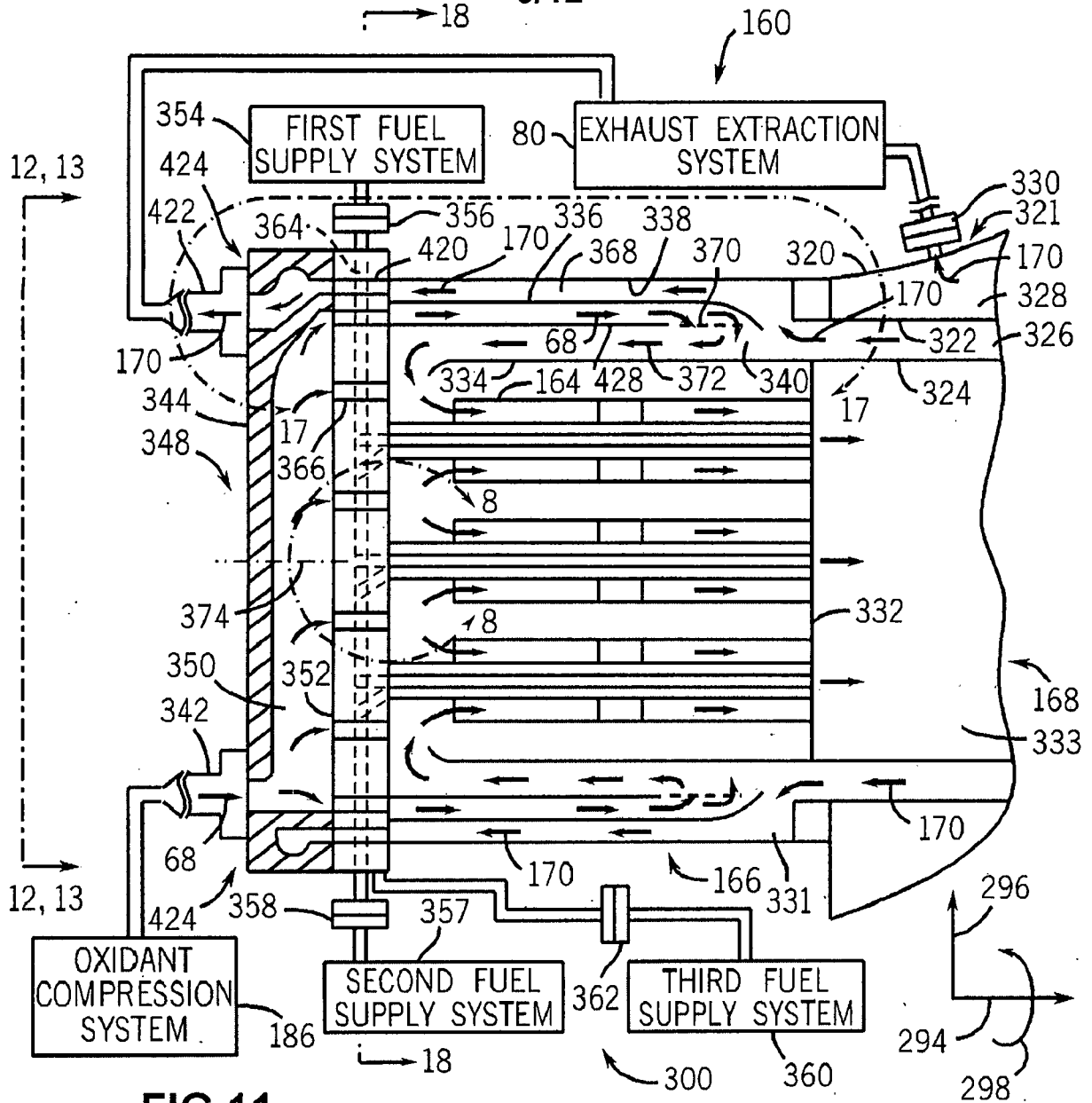

FIG. 11

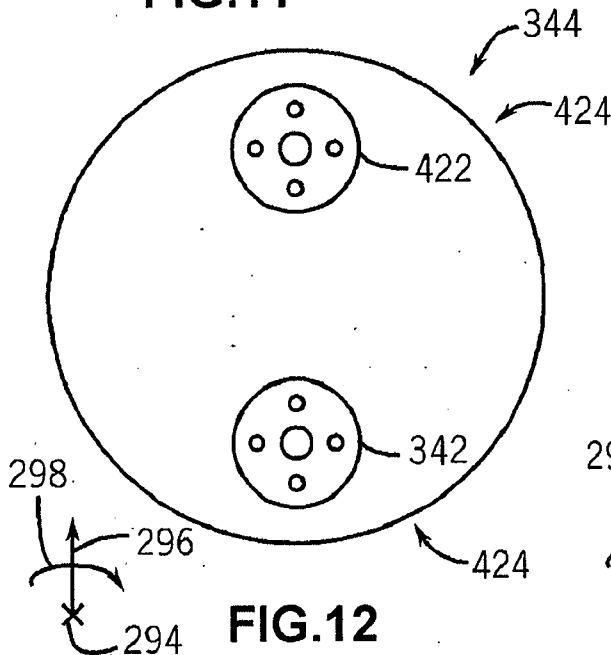

FIG. 12

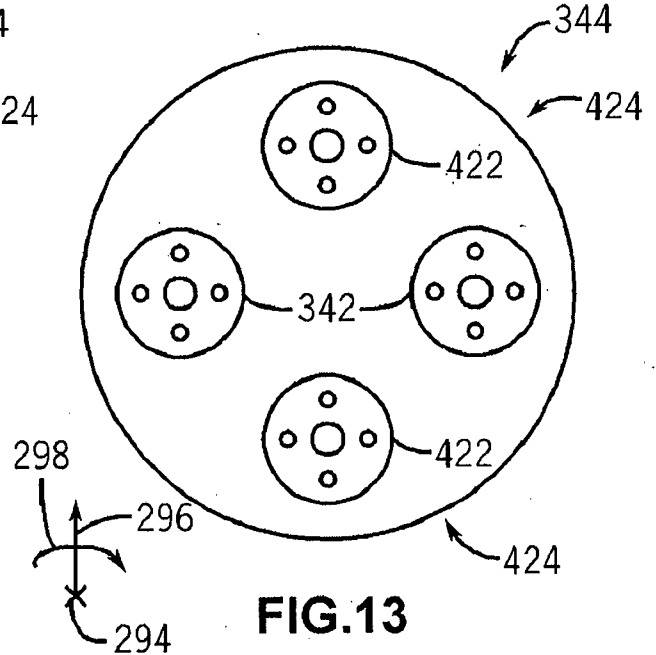
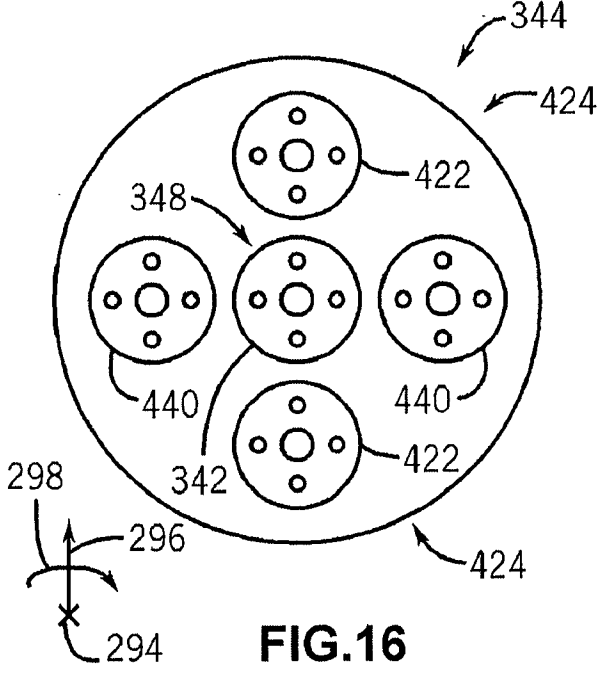
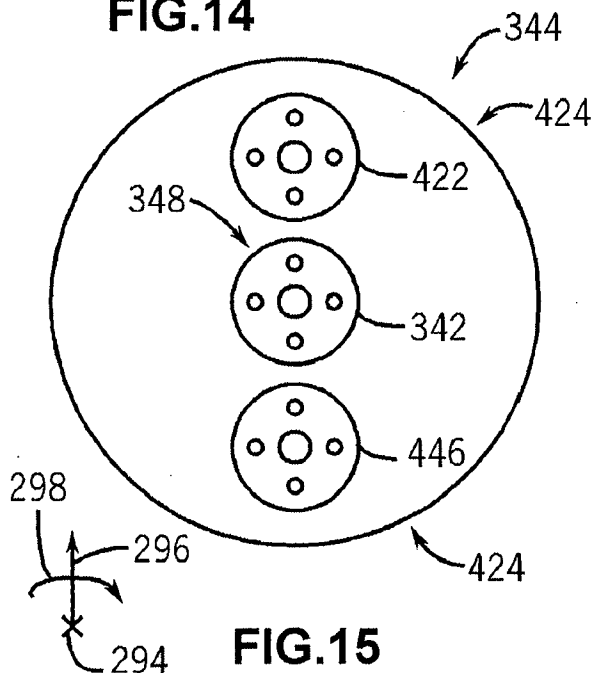
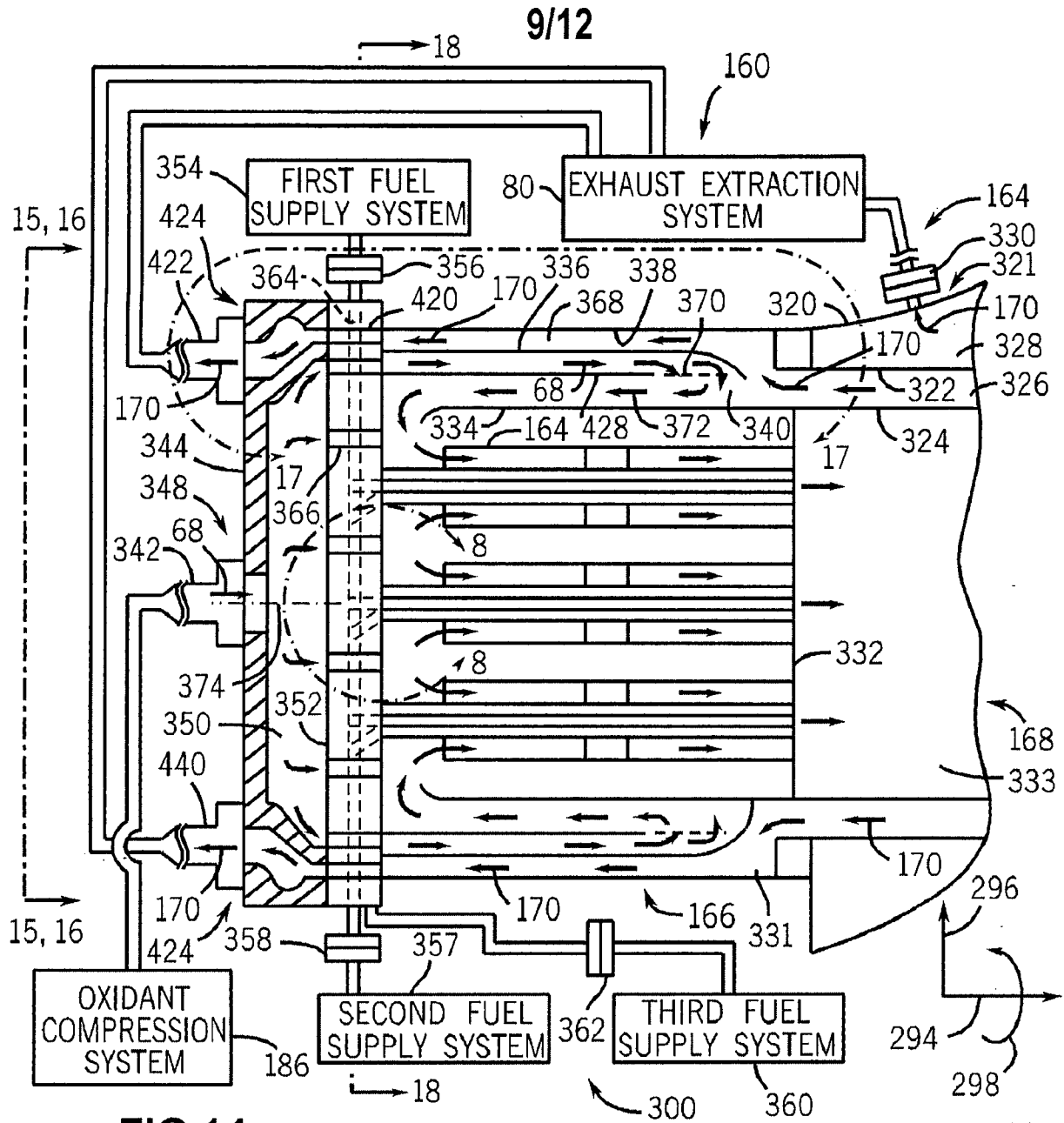

FIG. 13



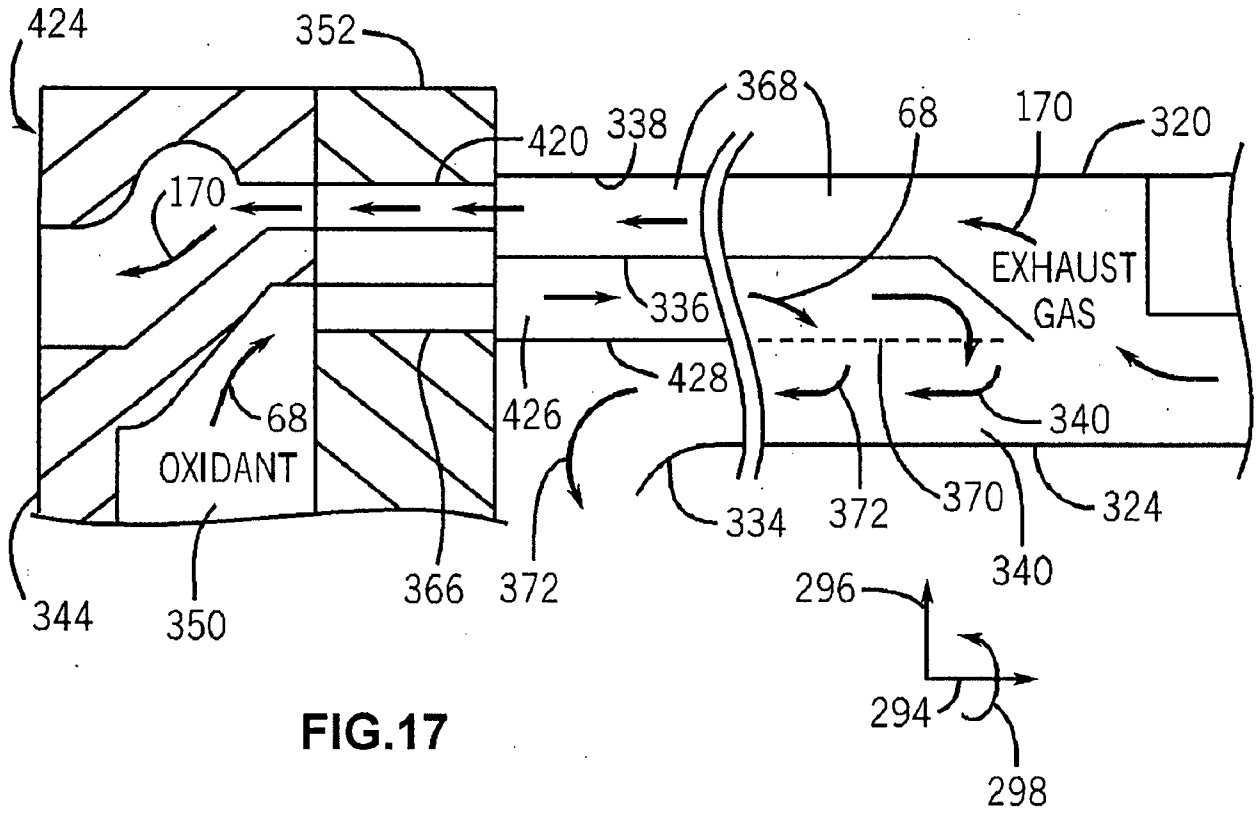

FIG. 17

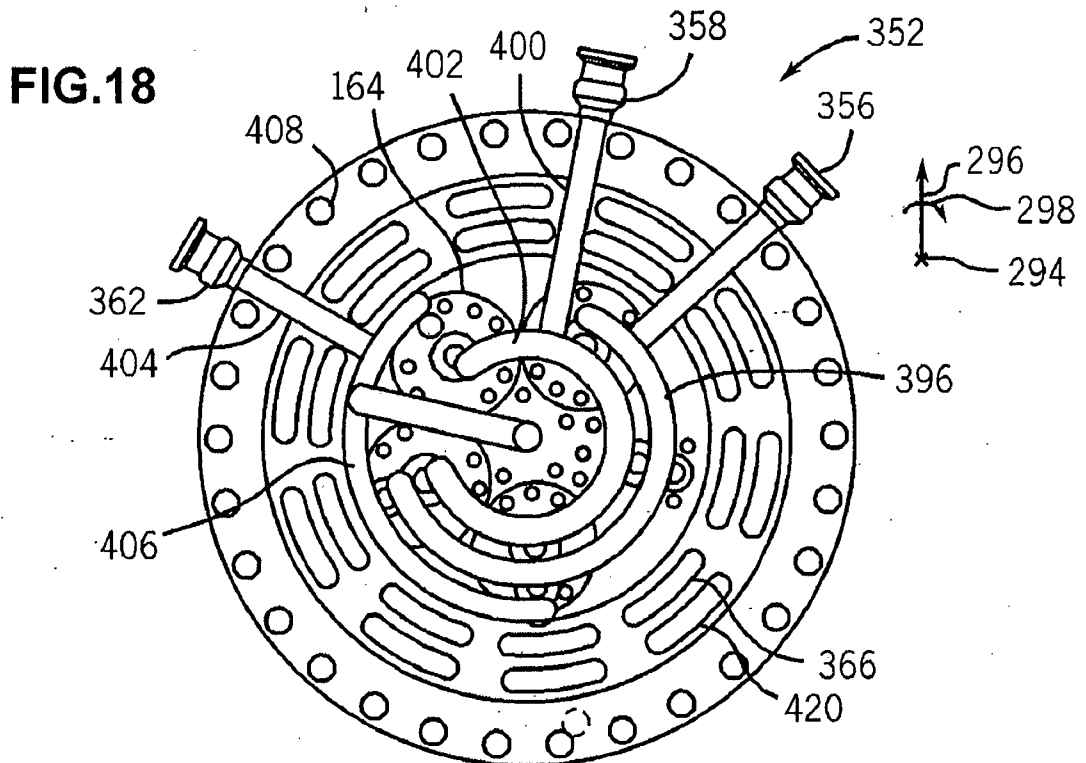

FIG. 18

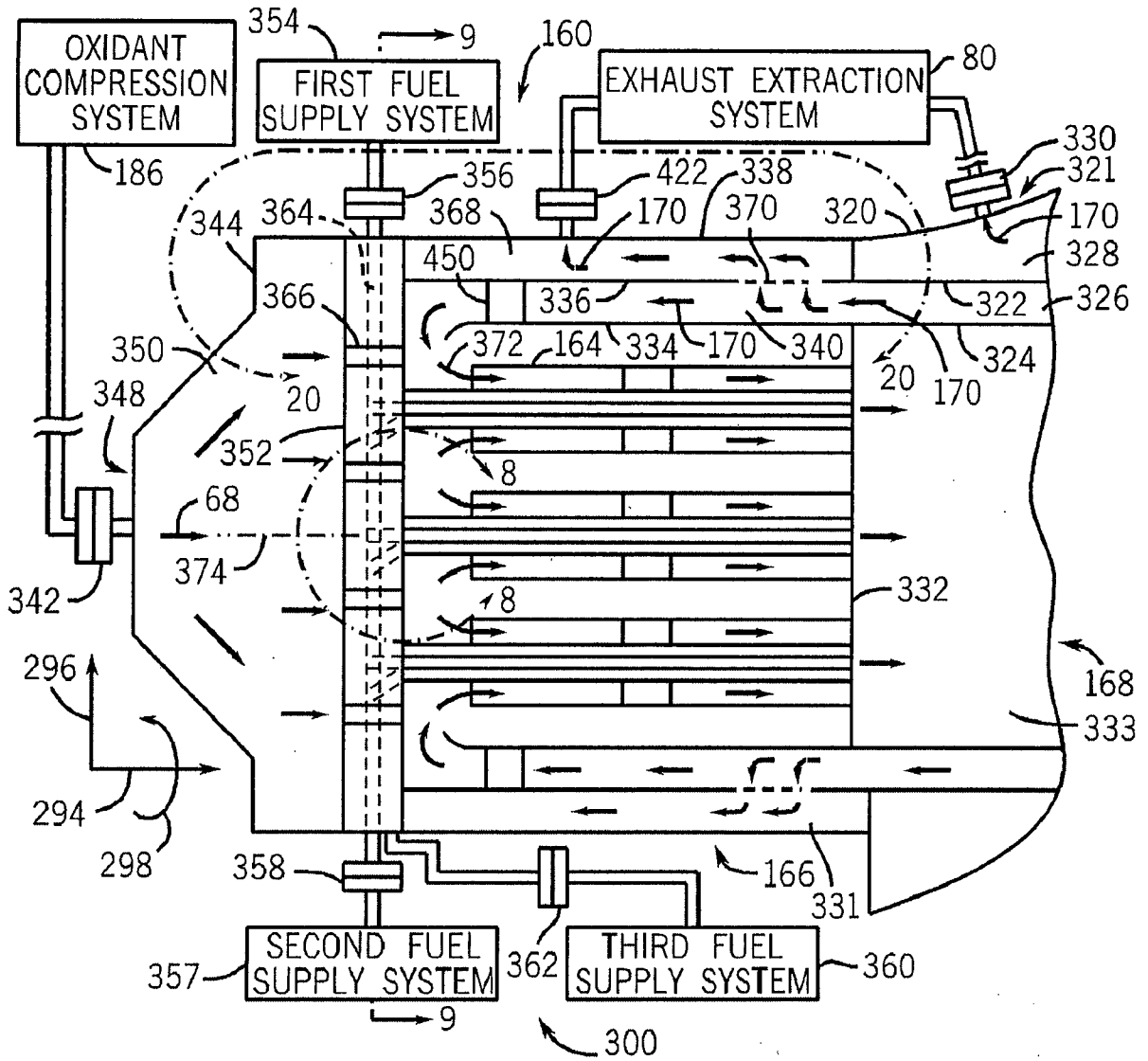

FIG.19

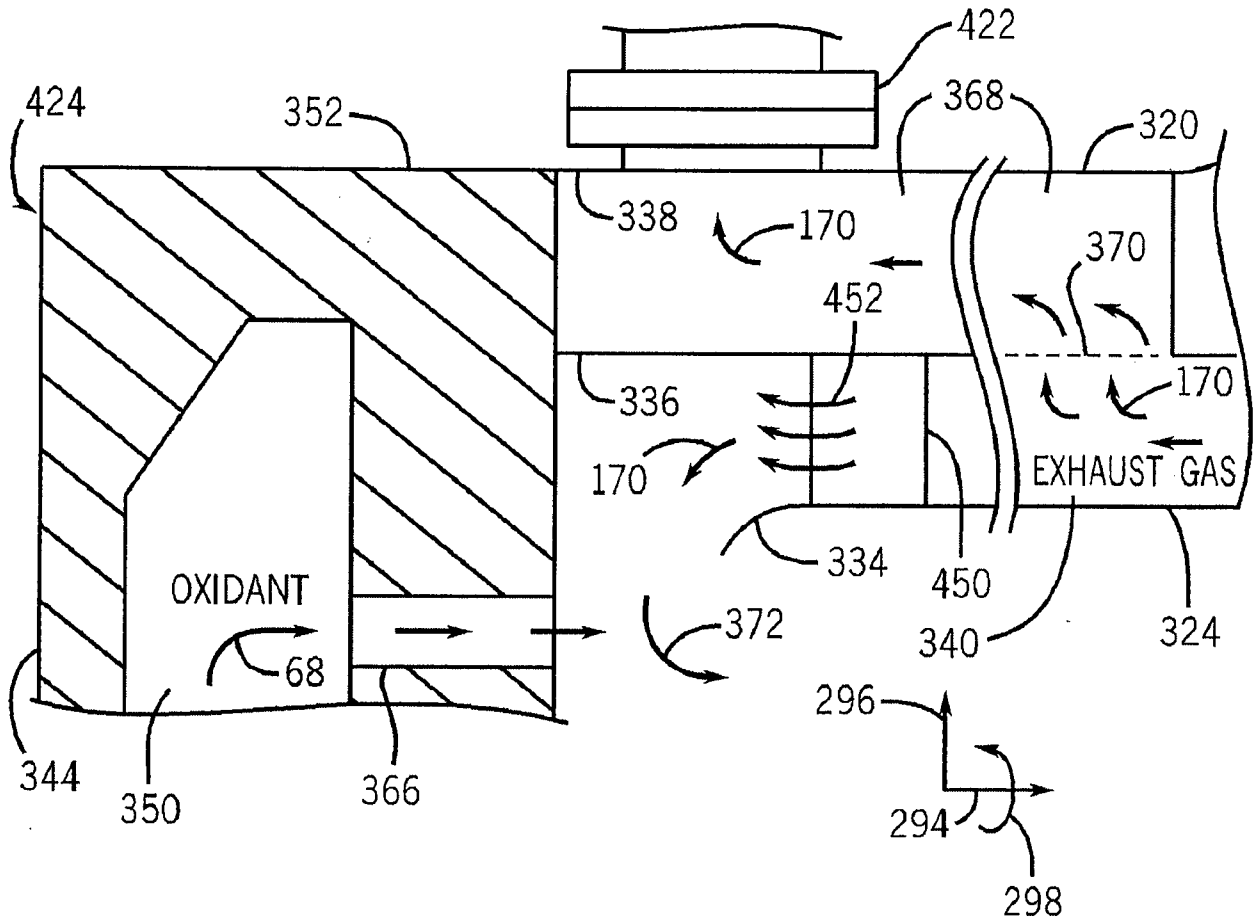

FIG.20

INTERNATIONAL SEARCH REPORT

International application No
PCT/RU2013/000162

A. CLASSIFICATION OF SUBJECT MATTER
 INV. F23C9/00 F23R3/28 F23R3/36
 ADD.
 According to International Patent Classification (IPC) or to both national classification and IPC

B. FIELDS SEARCHED
 Minimum documentation searched (classification system followed by classification symbols)
 F23C F23R

Documentation searched other than minimum documentation to the extent that such documents are included in the fields searched

Electronic data base consulted during the international search (name of data base and, where practicable, search terms used)
 EPO-Internal, WPI Data

C. DOCUMENTS CONSIDERED TO BE RELEVANT

Category*	Citation of document, with indication, where appropriate, of the relevant passages	Relevant to claim No.
X	EP 1 614 963 A1 (SIEMENS AG [DE]) 11 January 2006 (2006-01-11)	1-8,28, 45, 48-50, 52,53
Y	paragraphs [0047] - [0057]; figures	9,14,15, 25-27, 30,36, 37,39,46
X	----- US 2011/167828 A1 (SINGH ARJUN [IN] ET AL) 14 July 2011 (2011-07-14)	1,17,48
Y	paragraphs [0014] - [0023]; figures	18-24,31
X	----- GB 2 288 011 A (ABB MANAGEMENT AG [CH] ABB MANAGEMENT AG [CH]; ASEA BROWN BOVERI [CH]) 4 October 1995 (1995-10-04) figure 1 ----- -/--	1,48

Further documents are listed in the continuation of Box C.

See patent family annex.

* Special categories of cited documents :

"A" document defining the general state of the art which is not considered to be of particular relevance	"T" later document published after the international filing date or priority date and not in conflict with the application but cited to understand the principle or theory underlying the invention
"E" earlier application or patent but published on or after the international filing date	"X" document of particular relevance; the claimed invention cannot be considered novel or cannot be considered to involve an inventive step when the document is taken alone
"L" document which may throw doubts on priority claim(s) or which is cited to establish the publication date of another citation or other special reason (as specified)	"Y" document of particular relevance; the claimed invention cannot be considered to involve an inventive step when the document is combined with one or more other such documents, such combination being obvious to a person skilled in the art
"O" document referring to an oral disclosure, use, exhibition or other means	"&" document member of the same patent family
"P" document published prior to the international filing date but later than the priority date claimed	

Date of the actual completion of the international search 27 March 2014	Date of mailing of the international search report 03/04/2014
--	--

Name and mailing address of the ISA/ European Patent Office, P.B. 5818 Patentlaan 2 NL - 2280 HV Rijswijk Tel. (+31-70) 340-2040, Fax: (+31-70) 340-3016	Authorized officer Coli, Enrico
--	--

INTERNATIONAL SEARCH REPORT

International application No
PCT/RU2013/000162

C(Continuation). DOCUMENTS CONSIDERED TO BE RELEVANT		
Category*	Citation of document, with indication, where appropriate, of the relevant passages	Relevant to claim No.
Y A	WO 2012/018458 A1 (EXXONMOBIL UPSTREAM RES CO [US]; MITTRICKER FRANKLIN F [US]; HUNTINGTO) 9 February 2012 (2012-02-09) paragraph [0063]; figure 2	9,14,15, 30 10-13, 16,29, 32-35, 38,42, 47,51
Y	----- EP 2 511 496 A2 (GEN ELECTRIC [US]) 17 October 2012 (2012-10-17) the whole document	25,27,46
Y	----- WO 2010/044958 A1 (EXXONMOBIL UPSTREAM RES CO [US]; MITTRICKER FRANKLIN F [US]; STARCHER) 22 April 2010 (2010-04-22) the whole document	26
X Y	----- US 5 771 696 A (HANSEL HAROLD R [US] ET AL) 30 June 1998 (1998-06-30) the whole document	40,41, 43,44 18-24, 31,36, 37,39
X	----- US 2 537 054 A (HILDESTAD HAROLD L) 9 January 1951 (1951-01-09) figures -----	40

INTERNATIONAL SEARCH REPORT

Information on patent family members

International application No

PCT/RU2013/000162

Patent document cited in search report	Publication date	Patent family member(s)	Publication date
EP 1614963	A1	11-01-2006	NONE
US 2011167828	A1	14-07-2011	CH 702549 A2 15-07-2011 CN 102183040 A 14-09-2011 DE 102010061600 A1 14-07-2011 JP 2011141109 A 21-07-2011 US 2011167828 A1 14-07-2011
GB 2288011	A	04-10-1995	DE 4411624 A1 05-10-1995 GB 2288011 A 04-10-1995 JP H07280268 A 27-10-1995 US 5584182 A 17-12-1996
WO 2012018458	A1	09-02-2012	AR 082576 A1 19-12-2012 TW 201233891 A 16-08-2012 US 2013125554 A1 23-05-2013 WO 2012018458 A1 09-02-2012
EP 2511496	A2	17-10-2012	CN 102733955 A 17-10-2012 EP 2511496 A2 17-10-2012 US 2012260660 A1 18-10-2012
WO 2010044958	A1	22-04-2010	AU 2009303735 A1 22-04-2010 CA 2737133 A1 22-04-2010 CN 102177326 A 07-09-2011 EA 201170573 A1 31-10-2011 EP 2344738 A1 20-07-2011 JP 2012505987 A 08-03-2012 SG 195533 A1 30-12-2013 US 2011300493 A1 08-12-2011 WO 2010044958 A1 22-04-2010
US 5771696	A	30-06-1998	NONE
US 2537054	A	09-01-1951	GB 649658 A 31-01-1951 US 2537054 A 09-01-1951