

(Model.)

3 Sheets—Sheet 1.

E. JORDAN.

MACHINE FOR SQUARING SHEET METAL.

No. 250,254.

Patented Nov. 29, 1881.

Fig. 1. B

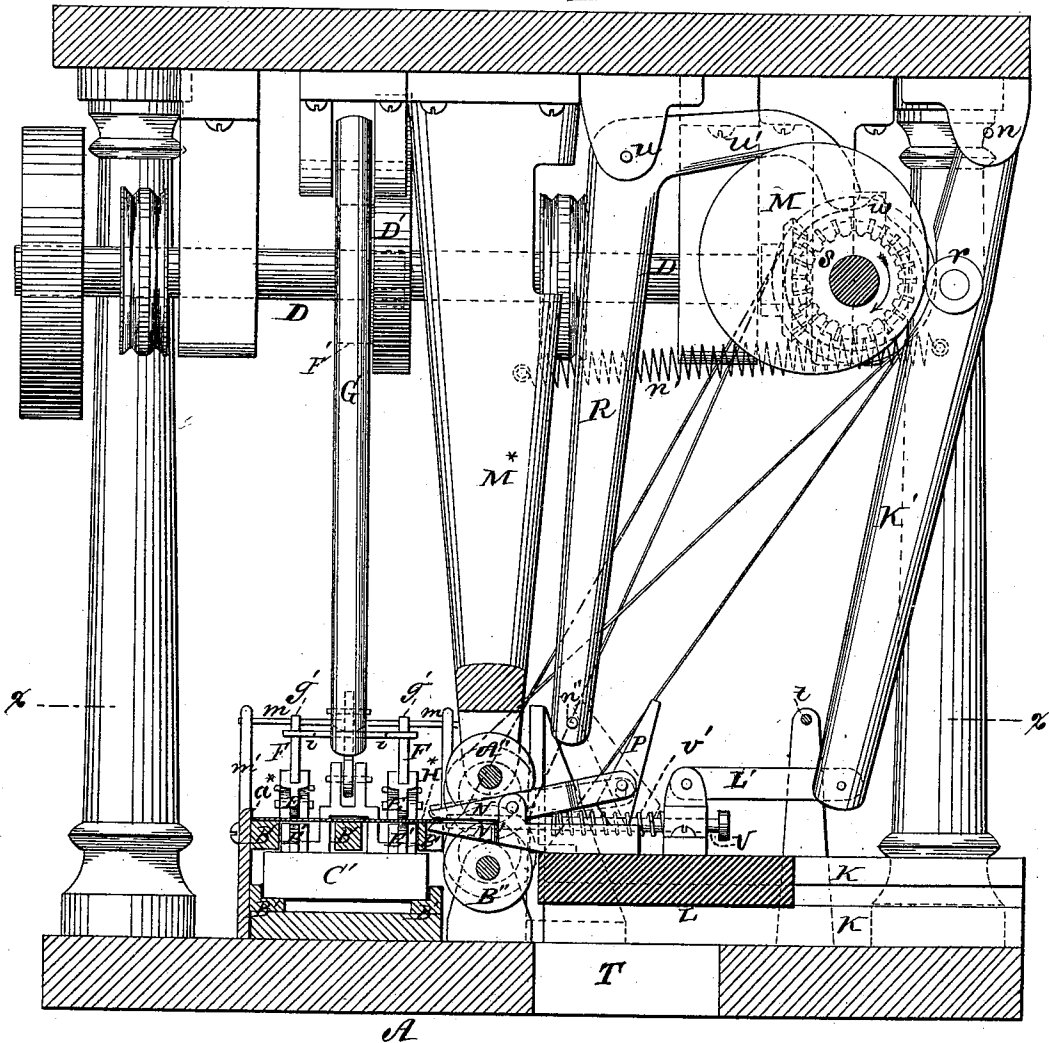

Witnesses.
Henry F. Parker
Robert W. Matthews

Inventor.
Edmund Jordan
per
James A. Whitney
Atty

(Model.)

3 Sheets—Sheet 2.

E. JORDAN.

MACHINE FOR SQUARING SHEET METAL.

No. 250,254.

Patented Nov. 29, 1881.

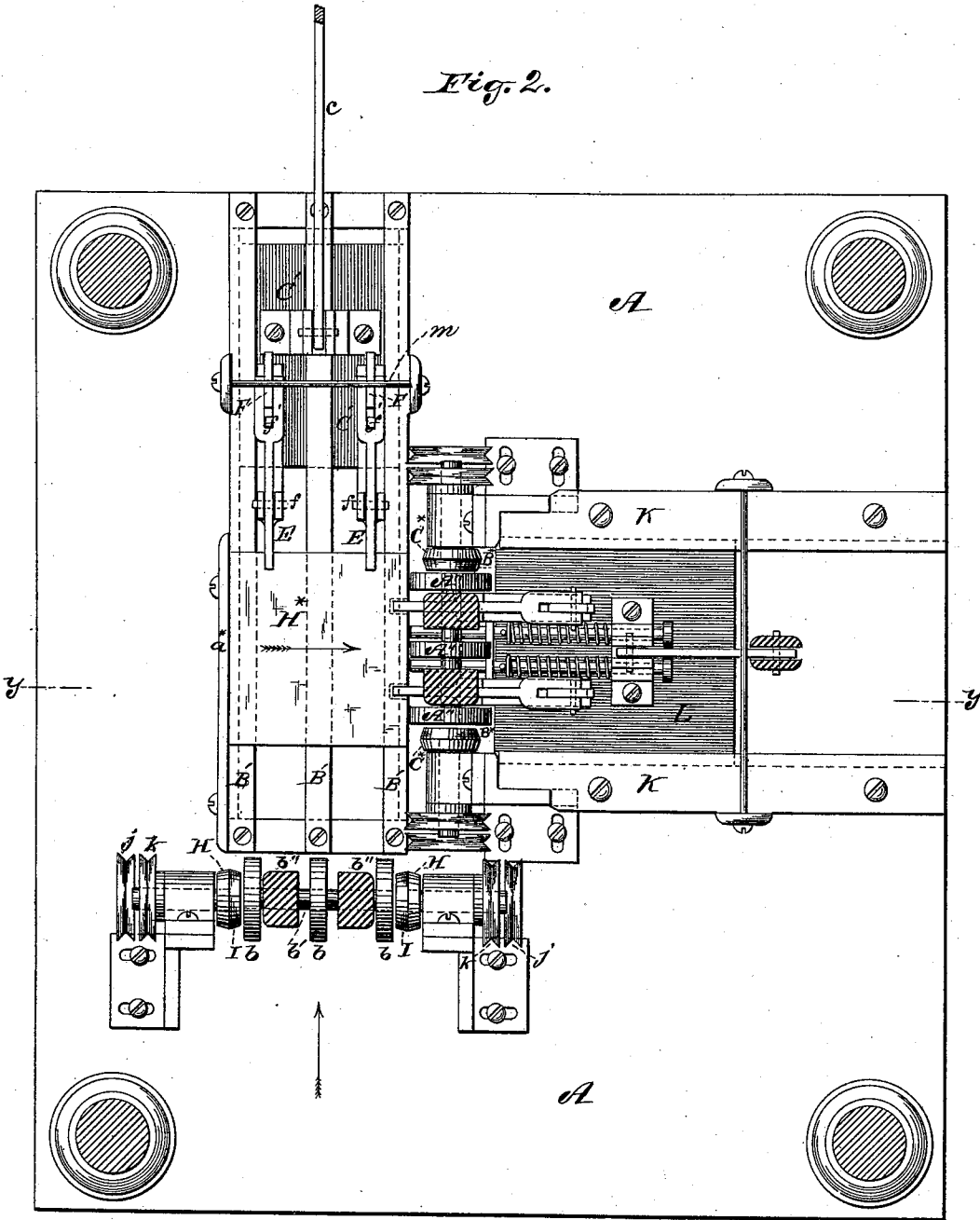

Witnesses.
 Henry R. Parker.
 Robert W. Matthews

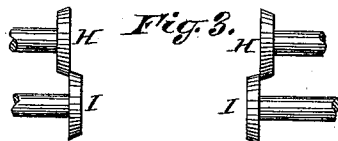

Inventor.
 Edmund Jordan
 per James A. Whitney
 Atty.

(Model.)

3 Sheets—Sheet 3.

E. JORDAN.

MACHINE FOR SQUARING SHEET METAL.

No. 250,254.

Patented Nov. 29, 1881.

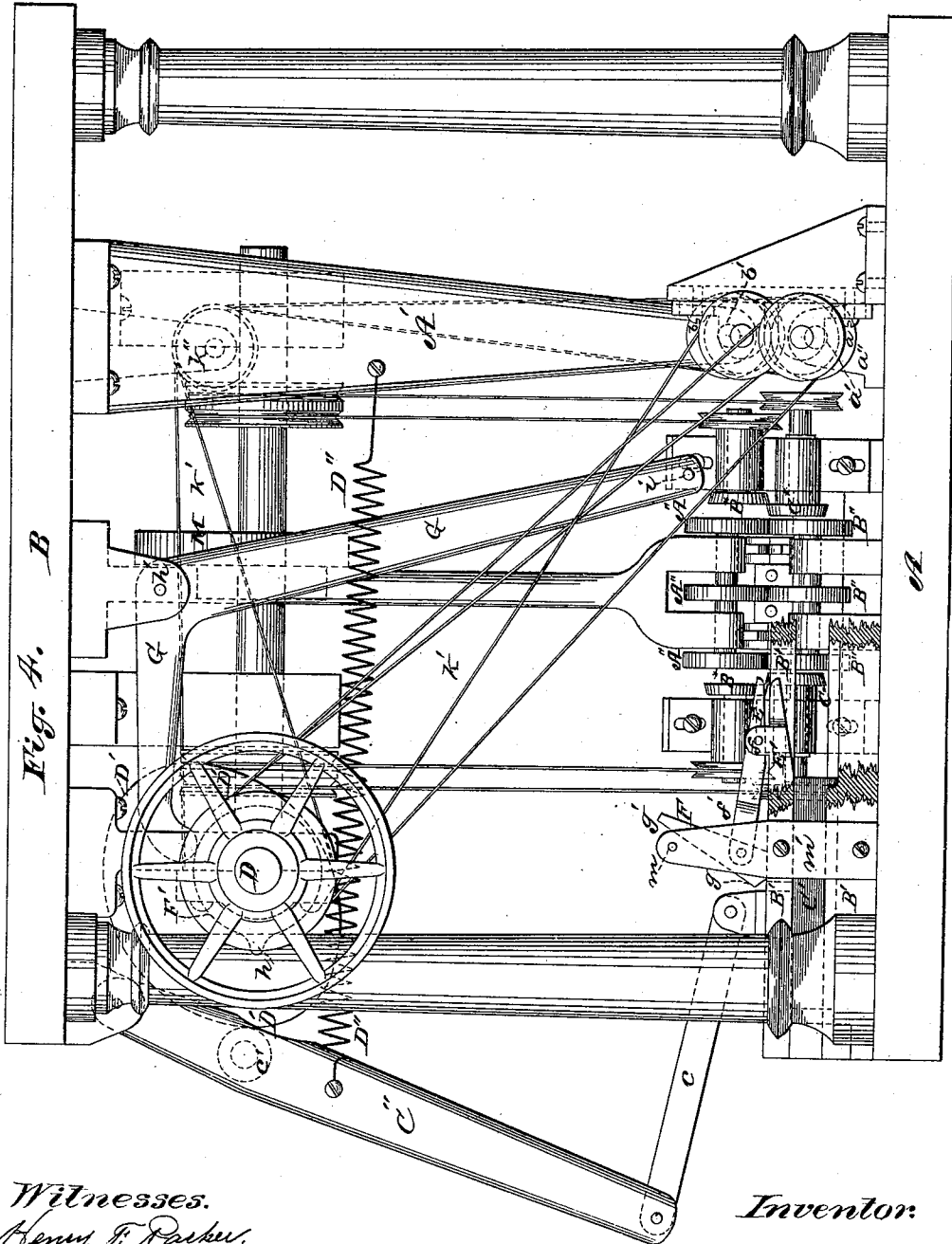

Witnesses.
Henry F. Parker.
Robert W. Matthews

Inventor:
Edmund Jordan
per James A. Whitney
Atty

UNITED STATES PATENT OFFICE.

EDMUND JORDAN, OF BROOKLYN, NEW YORK, ASSIGNOR TO ELIPHALET W. BLISS, OF SAME PLACE.

MACHINE FOR SQUARING SHEET METAL.

SPECIFICATION forming part of Letters Patent No. 250,254, dated November 29, 1881.

Application filed March 7, 1881. (Model.)

To all whom it may concern:

Be it known that I, EDMUND JORDAN, of Brooklyn, in the county of Kings and State of New York, have invented certain Improvements in Machinery for Squaring Sheet Material, of which the following is a specification.

The object of this invention is to provide an efficient automatic apparatus for giving a practically true rectangular form to sheets of metal or other material; and to this end the invention comprises certain novel combinations of parts, whereby the sheets of material being fed into the machine are automatically conducted through the latter and emerge therefrom with their edges trimmed or removed to bring the sheets to the required rectangular contour.

Figure 1 is a vertical transverse sectional view of an apparatus embracing the several features of my said invention, taken in the line *yy* of Fig. 2. Fig. 2 is a horizontal sectional view of said apparatus, taken in the lines *xx* of Fig. 1. Fig. 3 is a detail view, showing a portion of the cutting devices; and Fig. 4 is a side elevation and partial section in a plane at right angles to Fig. 1.

A suitable frame-work is provided to support the working parts, said frame-work comprising a base, A, for supporting the lower parts of the apparatus; a top, B, to enable the downwardly-extending levers, &c., to be suitably pivoted and supported, and intermediate standards for holding the top B in due relation with the base. The construction of this frame may, however, be modified in any suitable manner, it being only necessary that it should have a form or construction appropriate to sustaining and retaining in place the operative parts of the mechanism.

Shown at *aaa* are a lower series of rollers attached to a suitable shaft, *a'*, which works in appropriate bearings *a''* fixed on the base A. Immediately above and coincident with these rollers *aaa* are three other similar rollers, *bbb*, which are carried on a shaft, *b'*, working in suitable bearings *b''* in the lower end of a hanger, A', which depends from the top B of the frame. Immediately behind these rollers *aaa bbb* are horizontal ways or guides B', between which, arranged to move to and fro,

is a carriage, C', which said carriage receives its longitudinal movement by means of a lever, C'', pivoted to the top B of the frame of the machine, and having its lower end connected with the carriage C' by a pitman or connecting-rod, *c*. A shaft, D, working in bearings provided in suitable hangers from the top B, carries a cam, D', which works against an anti-friction roller. (Shown in dotted outline in *c'* at Fig. 4.) A spiral spring, D'', extending from the lever C'' to the hanger A', draws the anti-friction roller *c'* against the cam D' in such manner that the lever C'' shall receive the requisite movement because of the rotation of the cam D'', thereby giving a longitudinal movement in unison with the parts, hereinafter described, of the carriage C'. The carriage C' carries two pairs of nipping-jaws, E E'. The lowermost jaw, E', of each of these pairs is fixed upon the carriage C'. The uppermost jaw of each pair is pivoted to the adjacent lower jaw, E', by a pivot, *f*.

Pivoted to the rear extremity of the backwardly-extending arms *f'* of each of the upper jaws, E, is a lever, F, the lower end, *g*, of which bears upon the adjacent flat surface of the carriage C' in such manner that when the upper end, *g'*, of said lever is turned backward the lower end of said lever will act after the manner of a toggle-joint or skid to raise the arm *f'*, and thereby depress the jaw E toward the fixed lower jaw, E', so that the two jaws of each pair will firmly gripe any material placed between them, and also so that when the upper extremities, *g'*, of the said levers F are pushed forward they will permit the arms *f'* to descend by their own weight, thereby separating the two jaws of each pair aforesaid.

Upon the shaft D is a circular disk, (shown in dotted outline at F' in Fig. 4,) which has at a certain point of its circumference a rounded stud, *h*. An elbow-lever, G, is pivoted at *h'* to a suitable hanger depending from the top B of the frame-work. The upper or horizontal arm of this elbow-lever G rests upon the circumference of the disk F', while its vertical arm is provided at its lower extremity with the cross-piece *i*, which lies directly across the

pathway of the upper ends, g' , of the levers F, hereinbefore described, but at the end of the forward stroke of the carriage C', which carries the said levers.

5 Placed at each end of the two series of coincident rollers $a a a b b b$ is a pair of circular shears, H I, the shafts of which work in suitable bearings provided on the base A, and receive the requisite rotary motion, and which
10 are provided with pulleys $j k$, by which the requisite rotary motion may be given to the aforesaid rotary shears, the pulleys $j k$ receiving movement from belts $k' k'$, which pass over idler-pulleys h'' , as indicated in dotted
15 outline in Fig. 4, to a driving-pulley on the shaft D.

It will be observed that from the construction just hereinbefore described the sheet of sheet-iron or other material being thrust horizontally between the rollers $a a a$ and the rollers $b b b$ will have its rearmost edge brought between the jaws E E', assuming the carriage C' to have been moved to the end of its forward stroke. This done, the stud h of the disk F' is brought by the continuous rotation of the shaft D under the rearmost end of the horizontal arm of the lever G, and raising said horizontal arm swings backward the vertical arm of the said lever, and consequently causes
30 the cross-bar i to move backward the upper ends, g' , of the levers F, thereby causing the jaws E E' to gripe the rearmost edge of the sheet of material thrust between them, as hereinbefore explained; and inasmuch as the
35 levers F, when brought to a substantially vertical position, will not of themselves slip away from such position, it follows that the jaws E E' have a firm and solid gripe upon the aforesaid edge of the material passed between the rollers $a a a$ and $b b b$. As soon as the jaws
40 have thus griped the sheet of material the continued rotation of the cam D' swings backward the lever C'' and draws backward the carriage C', and of course therewith the jaws E E' and the sheet of material griped by the latter. During this operation the lateral edge portions of the sheet of the material pass between the rotary shears H I and are severed
45 from the sheet; and inasmuch as the sheet when drawn back, as just described, has a substantially true rectilinear movement, it follows that the lateral edges of the sheet are trimmed substantially parallel. When the carriage C' has been moved backward sufficiently
55 far to bring the sheet entirely through the rotary shears—in other words, to complete the trimming of the lateral edges—the upper ends, g' , of the levers F strike a fixed cross-bar, m , which is supported upon suitable standards
60 m' in such manner as to extend across the guides B' at a point slightly in advance of the limit of the rearward stroke of the carriage. When the ends g' of the levers F thus strike against the cross-bar m they are, so
65 far as concerns their relation with the carriage, moved forward, thereby depressing the rear-

wardly-extending arms f' of the jaws E, and enabling the latter to let go their gripe of the sheet of material drawn backward by them, as just hereinbefore explained. The sheet of material, which is represented at H* in the plan view, Fig. 2, when thus loosed from the gripe of the jaws E E', is brought immediately opposite another system of mechanism, which operates in substantially the same manner as that
70 just hereinbefore explained, but is placed at right angles to the latter, in such manner that by moving the sheet laterally in a direction at right angles to its former course its end edges may be trimmed parallel with each other and
80 at right angles to its lateral edges, already trimmed by the operation hereinbefore explained.

As concerns the mechanism for squaring the ends, it may be briefly described as follows:
85 Arranged at right angles to the guides or ways B', and, like the latter, supported on the base A, are other guides, K, between which moves a carriage, L, to which a rectilinear movement within the guides K is given by means of a lever, K', connected with the said carriage by a connecting-rod, L'. The lever K' has its pivot or fulcrum at its upper end, as shown at n in Fig. 1, and has attached to one of its sides an anti-friction roller, r , against which bears an
90 eccentric, M, the anti-friction roller being pressed against the periphery of the eccentric M by means of a spring, n' , extending from the lever K' to a hanger, M*.

The shaft s of the eccentric M is connected
100 by beveled gearing (indicated by dotted outline in Fig. 1) with the adjacent end of the shaft D, hereinbefore referred to, so that the shaft s is operated in unison with the parts hereinbefore described, with reference to the
105 cutting of the lateral edge portions of the sheet of material to be trimmed. Inasmuch as the lever K' receives a vibratory motion from the operation of the eccentric M, it follows that the rectilinear movement in the guides K is
110 given to the carriage L. This carriage L carries two or more arms, two griping-jaws, N N', which correspond in their construction to the griping-jaws E E', hereinbefore described with reference to the carriage C', the uppermost
115 jaw of each pair having connected therewith levers P, which correspond to the levers F of the jaws E.

Placed in a position a little within the limit of the outward stroke of the carriage L is a
120 transverse rod, t , which bears the same relation to the levers P and the jaws N that the horizontal rod m bears to the levers F of the jaws E E'.

R is an elbow-lever pivoted to the upper
125 part of the frame, as shown at U, and the upper and horizontal arm, U', of which rests upon the periphery of a disk, (shown in dotted outline in Fig. 1,) and which is provided with a radial rounded stud, (shown also in dotted
130 outline in Fig. 1 at w .) The said disk, with the stud w , bears the same relation to the lever

R that the disk F', with the stud *h*, bears to the lever G, hereinbefore described. The lever R is provided at its lower end with a transverse rod—in other words, with laterally-projecting arms *n''*—which bear the same relation to the levers P that the transverse rod of the levers G bears to the levers F.

Supported from the hanger M* are rollers A'' and B'', which bear the same relation to the jaws N' N' that the rollers *a* bear to the jaws E E', hereinbefore described.

Provided in suitable bearings supported on the base A are pairs of cutters, B* C*, which bear the same relation to the rollers A'' and to the jaws N' N' that the cutters H I bear to the rollers *a*. The shears B* C* are placed in such position that when the blank H* is brought to the end of the backward stroke of the carriage C', as hereinbefore explained, it is brought immediately in front of the rollers A'' B'', with its end portions extending laterally beyond the rotary shears B* C*. When the blank H* is brought to this position by the operation hereinbefore fully explained the jaws N' N' are approaching the limit of their inward stroke, and this stroke being continued until the jaws N are brought above and the jaws N' below the adjacent lateral edge portion of the sheet H*. The levers P are brought to their vertical position by the movement of the lever R, thereby causing the jaws to gripe the edge of the sheet between them and to retain a gripe or hold thereon in the same manner that the jaws E E' are caused to gripe the sheet at the beginning of the operation of the machine, as hereinbefore set forth. This done, the succeeding reverse or outward movement of the carriage L draws the jaws N N', and consequently the sheet H*, between the rollers A'' B'' and between the rotary shears B* C*, in the manner substantially the same as that in which the sheet was first drawn between the rollers *a b* and the cutters H I. This outward movement of the carriage L therefore causes the shears B* C* to cut off the end edges from the sheet H* just as the lateral edges of the said sheet have been previously cut; and, inasmuch as the mechanism for cutting the end edges is at right angles, or substantially so, to the mechanism for cutting the lateral edges, it follows that the end edges will be cut at right angles, or substantially so, to the lateral edges and the sheet be given a substantially true rectangular configuration. The sheet, being thus trimmed to the required contour, is discharged from the jaws N N' downward through an opening, T.

In order to secure the speedy and effectual discharge of the finished sheet, as just indicated, there is provided upon the carriage L two horizontal rods, V, which work in suitable guides or bearings provided for them on the said carriage L, and which are pressed in an inward direction by spiral springs V', indicated at Fig. 1. There is, furthermore, pro-

vided at the outer lateral edge of the guides B' an upwardly-extending flange or ledge, *a**, so that when the jaws N N' move inward to gripe the adjacent end edge of the sheet H* the inner ends of the rods V will strike against the said edge of the said sheet, the latter being held against the elastic thrust of the rods V by the flange or ledge *a** until the jaws N N' have consequently griped the said edge of the sheet, as hereinbefore explained. When the carriage L approaches the limit of its outer stroke the upper ends of the levers P strike the cross-rods *t*, and are thrown forward or inward, thereby causing the jaws to separate and release their gripe upon the sheet H*, whereupon the rods V, being moved inward by the spring *v'*, throw the finished sheet away from said jaws, so that the said sheet falls easily through or into the opening T, thereby permitting the jaws N N' to again move inward for repetition of their operation upon a succeeding sheet.

What I claim as my invention is—

1. In a machine for trimming and squaring sheet material, the combination of two edge-trimming devices placed in position substantially at right angles to each other, arranged to act one after the other, and connected by mechanism, substantially as specified, to operate the two in unison, all substantially as and for the purpose set forth.
2. In a machine for trimming and squaring sheet material, the series of rollers *a b*, the rotary shears H H', and mechanism, substantially as indicated, for drawing the material in combination with the series of rollers A'' B'' and the rotary shears B* C*, and mechanism, substantially as indicated, for drawing the sheet material from the last-mentioned rollers and shears after the same has passed from the first-mentioned rollers and shears and in a direction at right angles to its first line of travel, all substantially as and for the purpose herein set forth.
3. In a machine for trimming and squaring sheet metal, the combination of a series of feed-rollers, duplicate pairs of rotary shears, and the carriage bearing the gripping-jaws for drawing the sheet material through the aforesaid rollers and shears, and a guide or way for sustaining the carriage during its reciprocating movement, and mechanism, substantially as indicated, for operating the said carriage in unison with the aforesaid rollers and shears, all substantially as and for the purpose herein set forth.
4. In a machine for trimming sheet material, the combination of a carriage, C', carrying the jaws E E', the levers F attached to the upper end of the said jaws, swinging lever G, and fixed cross-bar *m*, the rollers *a b*, and the duplicate pairs of rotary shears, the whole arranged for joint operation substantially as and for the purpose herein set forth.
5. In a machine for trimming and squaring

sheet material, the combination of two mechanisms, each consisting of a carriage carrying gripping-jaws, levers for opening and closing the gripping-jaws, rollers for feeding the material to the gripe of the jaws, and shears for cutting the material as it passes through the rollers, the systems of mechanism being placed

to operate at right angles to each other, substantially as and for the purpose herein set forth.

EDMUND JORDAN.

Witnesses:

ROBERT W. MATTHEWS,
THOMAS E. CROSSMAN.