

(No Model.)

2 Sheets—Sheet 1.

J. P. COLEMAN.
SIGNAL APPARATUS.

No. 566,499.

Patented Aug. 25, 1896.

FIG. 1.

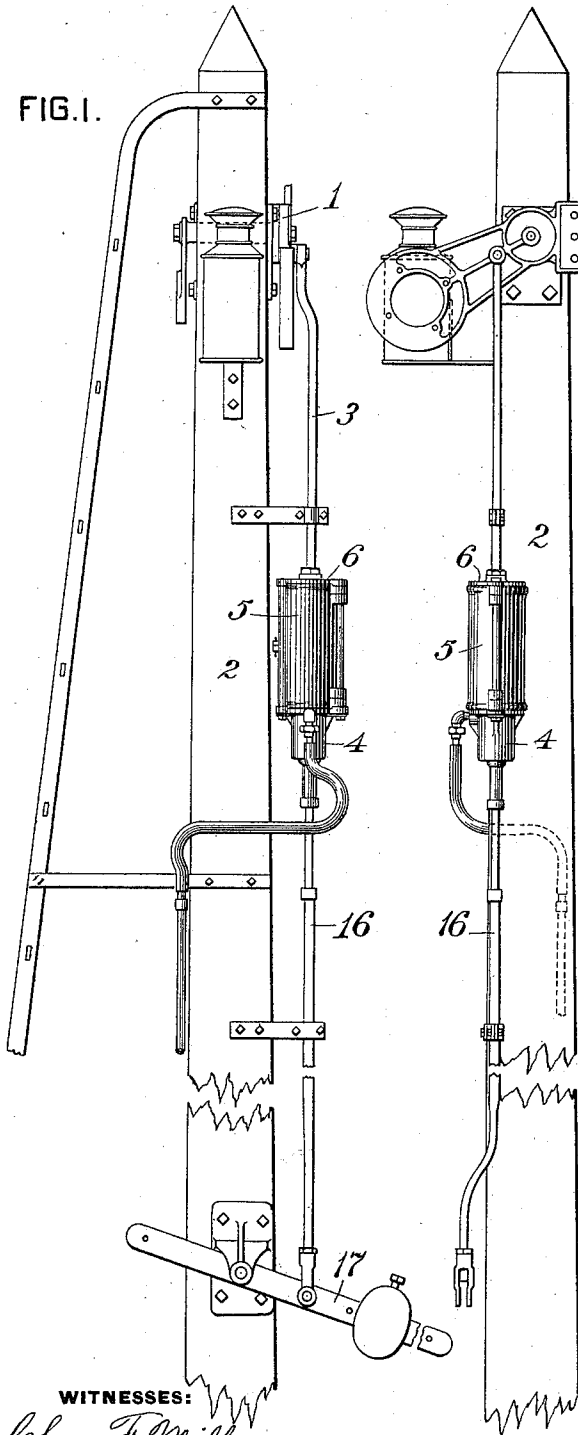

FIG. 2.

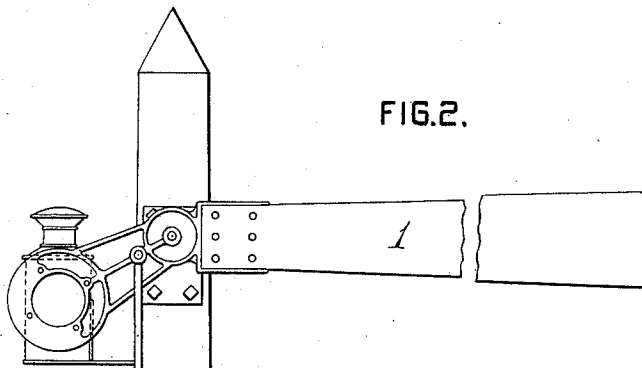

FIG. 6.

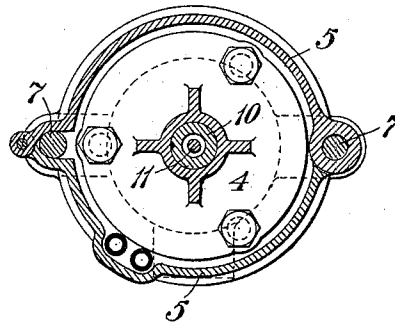
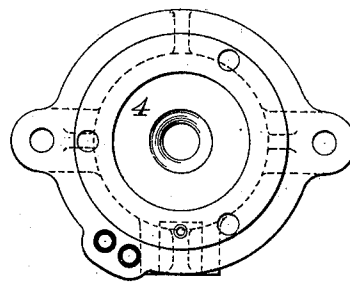

FIG. 5.



WITNESSES:

Chas. F. Miller.
A. E. Gaither

INVENTOR,

John P. Coleman
by *Dennis B. Wolcott*

Att'y.

J. P. COLEMAN.
SIGNAL APPARATUS.

No. 566,499.

Patented Aug. 25, 1896.

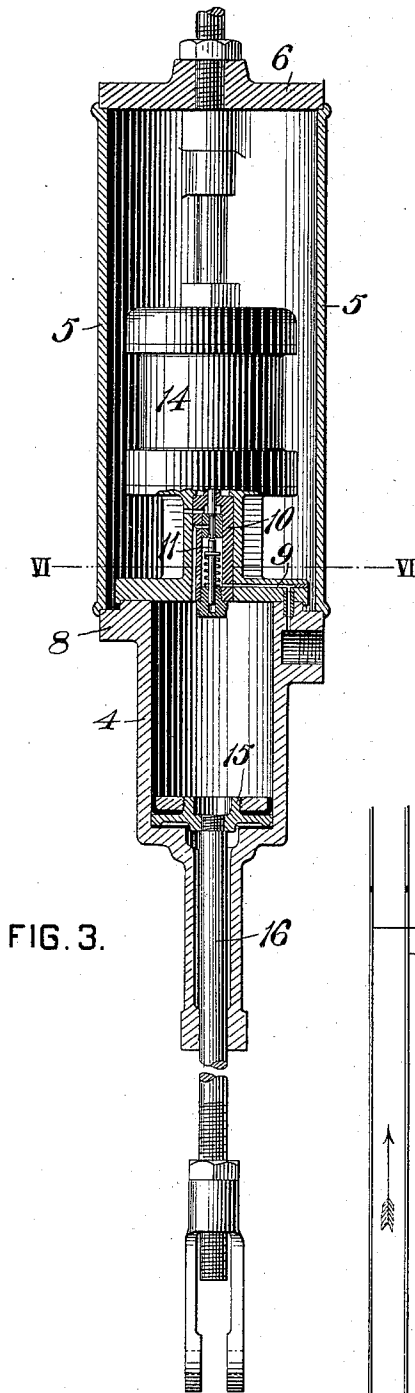

FIG. 3.

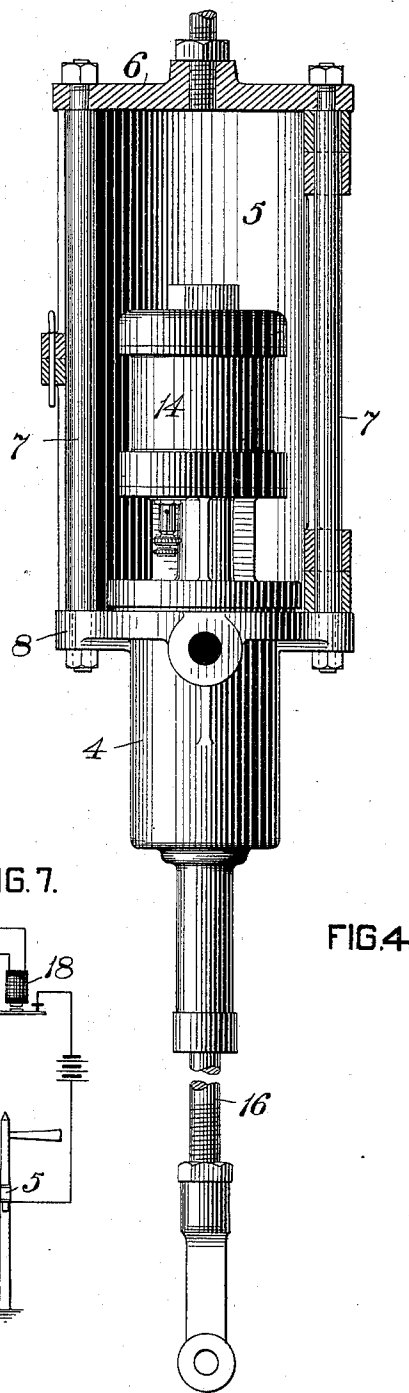

FIG. 4.

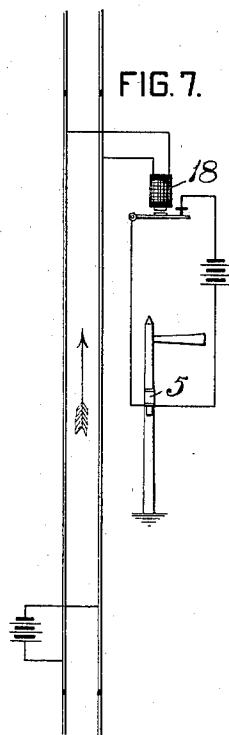

FIG. 7.

WITNESSES:

Chas. F. Miller.
J. E. Yaither

INVENTOR,

John Pheley Coleman
by Saml. S. Wolcott

Att'y.

UNITED STATES PATENT OFFICE.

JOHN PRESSLEY COLEMAN, OF EDGEWOOD PARK, PENNSYLVANIA, AS-SIGNOR TO THE UNION SWITCH AND SIGNAL COMPANY, OF SWISS-VALE, PENNSYLVANIA.

SIGNAL APPARATUS.

SPECIFICATION forming part of Letters Patent No. 566,499, dated August 25, 1896.

Application filed May 21, 1896. Serial No. 592,393. (No model.)

To all whom it may concern:

Be it known that I, JOHN PRESSLEY COLEMAN, a citizen of the United States, residing at Edgewood Park, in the county of Allegheny and State of Pennsylvania, have invented or discovered certain new and useful improvements in Signal Apparatus, of which improvements the following is a specification.

The invention described herein relates to certain improvements in that class of signal mechanism known as "slots," whereby a signal which has been set at "safety" may, by the passage over the track-section guarded by said signal, be returned automatically to "danger" and be retained in such position, even if the operator should attempt to clear it, while the train is in the guarded section.

The invention has for its object the employment of a fluid-pressure cylinder for controlling the movements of a mechanically-actuated signal; and it consists, generally stated, in the construction and combination substantially as hereinafter described.

In the accompanying drawings, forming a part of this specification, Figure 1 is a front elevation of a signal having my improvement applied thereto. Fig. 2 is a side elevation of the same. Figs. 3 and 4 are sectional elevations on vertical planes at right angles to each other through the fluid-pressure slot, on an enlarged scale. Fig. 5 is a top plan view of the fluid-pressure cylinder; and Fig. 6 is a sectional plan, the plane of section being indicated by the line VI VI, Fig. 3.

In the practice of my invention the signal 1, which is preferably of the semaphore type, is mounted on the post 2, in such manner as is customary, to automatically return to normal or danger position when free to move. A rod 3 is connected at one end to the signal-blade and at its lower end to the cylinder 4, preferably through the medium of the case or shell 5, to the head 6 of which the lower end of the rod 3 is connected. This case or shell is formed in two sections hinged to one of the rods 7, connecting the head 6 with a flange 8, formed on the upper end of the cylinder 4. These hinged sections of the shell inclose the electrically-controlled valve mechanism which regulates the flow of fluid-pressure to

and from the cylinder 4. On the cylinder 4 is formed a nipple, to which the fluid-pressure-supply pipe is connected, and this nipple is connected by a port 9, formed in the head of the cylinder, with passages in the valve case or shell 10, within which are formed suitable passages controlled by the pin-valve 11, which is connected to the armature of the electromagnet 14. As this construction of valve mechanism is well known in the art, and is described and shown in several patents, notably No. 358,521, granted the 1st day of March, 1887, to George Westinghouse, a further description of it is not deemed necessary herein. Within the cylinder 4 is arranged the piston 15, whose rod 16 is connected to the balance-lever 17 on the post 2. This balance-lever has its ends connected by wires, in the usual manner, to a signal-operating lever. (Not shown.)

As shown in the diagrammatic figure, the electromagnet 14 is included in a circuit which also includes the front stop and armature of a relay 18, included in the track-circuit, in the customary manner.

When the signal is at "danger" and the balance-lever in its normal position, as shown in Fig. 2, the piston will be at the lower end of a cylinder and subjected to pressure on its upper side, for the reason that the circuit through the magnet 14 is closed, the track-section being unoccupied, and the valve controlling the flow of fluid-pressure to the cylinder 4 is therefore open. If the operator should now reverse his lever, the signal will be cleared, as the pressure in the cylinder 4 will prevent any movement of the piston therein, and the cylinder will move up with the piston. The signal being cleared, a train is free to pass upon the section controlled by said signal, but as soon as a train enters the section, short-circuiting the track-relay, the circuit through the magnet 14 will be broken, thereby permitting the pressure-controlling valve to be shifted, so as to cut off fluid-pressure from the cylinder and open the exhaust-port therefrom, thereby permitting the cylinder to drop and shift the signal to danger position. As long as the train occupies the section, thereby holding the signal-circuit

open and the pin-valve in exhaust position, any movement of the signal-operating lever, and with it the piston, will not have any effect upon the cylinder and signal, but as soon
5 as the signal-circuit is closed by the passage of the train off from the section the controlling-valve will be shifted, thereby closing the exhaust-port and admitting fluid-pressure to the cylinder, so that if the operating-lever is
10 still in reverse position the signal will go automatically to "safety," or, if the lever has been returned to normal position, the fluid-pressure will flow in on top of the piston, so that the signal may be cleared by a reversal of the
15 operating-lever, the pressure in the cylinder locking, as it were, the piston and cylinder together.

I claim herein as my invention—

1. The combination of a signal, a mechanical device for operating the signal, a fluid- 20 pressure cylinder, a piston forming the pneumatic slot between the signal and the mechanical device, substantially as set forth.

2. The combination of a signal, mechanism 25 for operating the signal, a fluid-pressure cylinder and piston connecting the signal and its operating mechanism, and an electrically-controlled valve mechanism for controlling the flow of fluid-pressure to and from the cylinder, substantially as set forth. 30

In testimony whereof I have hereunto set my hand.

JOHN PRESSLEY COLEMAN.

Witnesses:

F. E. GAITHER,
DARWIN S. WOLCOTT.