

C. S. Moseley,
Punching Watches.

No. 104,755.

Patented June 28, 1870.

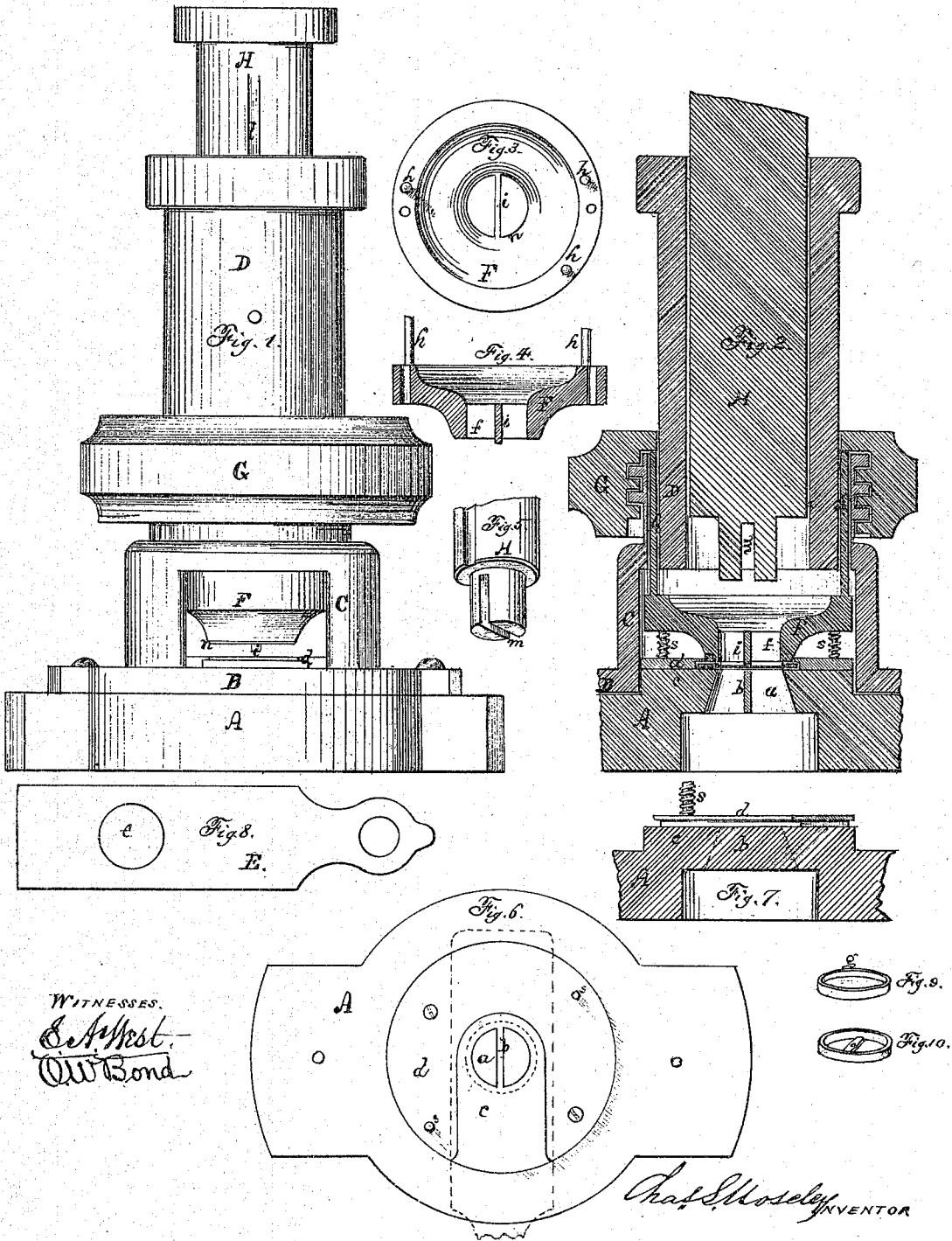

WITNESSES.
C. West.
W. Bond.

Chas. Moseley INVENTOR

United States Patent Office.

CHARLES S. MOSELEY, OF ELGIN, ILLINOIS.

Letters Patent No. 104,755, dated June 28, 1870.

IMPROVEMENT IN PUNCHING-MACHINE.

The Schedule referred to in these Letters Patent and making part of the same.

I, CHARLES S. MOSELEY, of the city of Elgin, in the county of Kane and State of Illinois, have invented a certain new and useful improvement in Punching-Machines, of which the following is a full description, reference being had to the accompanying drawing making a part of this specification, in which—

Figure 1 is an elevation.

Figure 2, a vertical section.

Figure 3, a top view of the holder F.

Figure 4, a vertical section of the same.

Figure 5 a detached view, showing the lower end of the piston H.

Figure 6, a top view of the lower die.

Figure 7, a section of the same, taken at right angles to that shown in fig. 2.

Figure 8 is the slide.

Figure 9, a blank to be cut.

Figure 10, the same after being cut.

In manufacturing compensating balances for watches a steel disk is made, having a rim or flanch of the same material, around which rim is placed a rim of brass, the two being united so as to form a single rim.

The greater portion of the disk within the rim is then cut out by means of hand and lathe-work, leaving only a narrow cross-bar from side to side.

It has been supposed that this work could not be performed by a punch, as great accuracy is required and displacement or unequal stretching of the remaining parts must be avoided.

The object of my invention is to construct a punch by the use of which this work can be performed as well as by the old method, and without injury to the balance; and I accomplish this by so constructing my improved machine that every part of the blank, from which the balance is to be made, excepting those parts which are to be cut out, will be supported, and held firmly in place between opposing surfaces while being punched.

The several parts of my machine are made of metal. In the drawing—

A represents the bottom portion die of my machine, which is a part of or permanently secured to the bed of the machine, the hole *a* in this piece being at the top just as large as the disk within the rim of the blank from which the balance is to be made, and across this hole *a*, from side to side, is a solid bar, *b*, of the same width as the bar in the balance after it has been punched, so that the rim of the blank, and that portion forming the bar after punching, rest upon solid metal while in the machine.

B C D form a single hollow piece.

B is a flange, which fits over the raised portion *c* of the die A, *c* and B being of the same thickness.

As shown, *d* is a separate piece, secured to *c*, having grooves for the purpose of guiding the slide E, fig. 8.

This slide is just as thick as the blank to be punched, which is represented by fig. 9, and in this slide a hole, *e*, the same size as the blank.

The part C is hollow and open on two sides, and within this part I place a movable holder, F, the form of which will be seen in figs. 1, 2, 3, and 4.

In this piece F is a hole, *f*, of the same size as the hole in A, and across it is a solid metal bar, *i*, corresponding with the similar bar *b*.

This bar *i* projects below the other parts of F a distance equal to the distance which the rim of the blank *g* extends above the disk.

This holder is so arranged in the machine that the bar *i* is exactly over the bar *b*, and the edge *n* of the edge of the hole *a*.

Three metal rods, *h*, are fastened to F, which extend up through holes in the enlarged part of F, which enlarged part is provided with a screw-thread.

The nut G is provided with a female screw, and used to force F down upon the blank and hold it while being punched.

As shown, the upper ends of these rods *h* are contact with a shoulder within G, which, when G is screwed down, forces F down also.

This may be accomplished in other ways. Notches might be made in the rods near the top and on the outside, and a plate or ring fitting the notches could be fastened to the under side of G for the purpose of lowering and raising F.

As shown, it is raised by means of two springs, *k*, beneath it.

D is hollow, for the purpose of receiving the piston H.

The lower end of this piston exactly fits the hole in F and A, and has a slit or opening, *m*, in it corresponding with the bars *b* *i*, and large enough to allow the piston to pass down over them.

This part of the piston is represented in fig. 5.

The piston is kept in proper position by means of the groove *l* and a corresponding stop.

In fig. 1, the holder F is represented raised, so as to permit the slide E, containing a blank, to be passed in beneath F to the position it occupies when the blank is ready to be punched.

In fig. 2, this part F is represented forced down upon the blank, which is shown in the slide, while the piston is raised ready for the stroke.

The operation of my device is as follows:

The part F having been first raised a little, the slide E, having a blank, *g*, in *e*, is placed in its proper position, which is determined by a suitable stop, while the rim of the blank *g*, and that part of the disk over the bar *b*, will rest upon solid metal.

The holder F will then be screwed down tight upon the blank, the bar *i* coming in contact with the

isk, and exactly over the bar *b*, while the lower edge of the holder *F* will be in contact with the rim of the blank *g*, so that every part of the blank, except that which is to be cut away by the end of the piston, will be supported and held firmly in place between opposing surfaces.

The piston *D* is then forced down with such force as may be necessary, instantly cutting out all of the disk of the blank except that between the bars *b* *i*, and leaving only the rim and a central bar, as seen in Fig. 10, thus saving much labor and leaving the balance uninjured.

The piston is operated in the usual manner, and its descent arrested by well-known devices.

What I claim as new is as follows:

The combination of the annular holder *F* and bar *i*, and the die *A* and bar *b*, with the bifurcated piston or punch *H*, as and for the purposes set forth.

CHAS. S. MOSELEY.

Witnesses:

E. A. WEST,
O. W. BOND.