

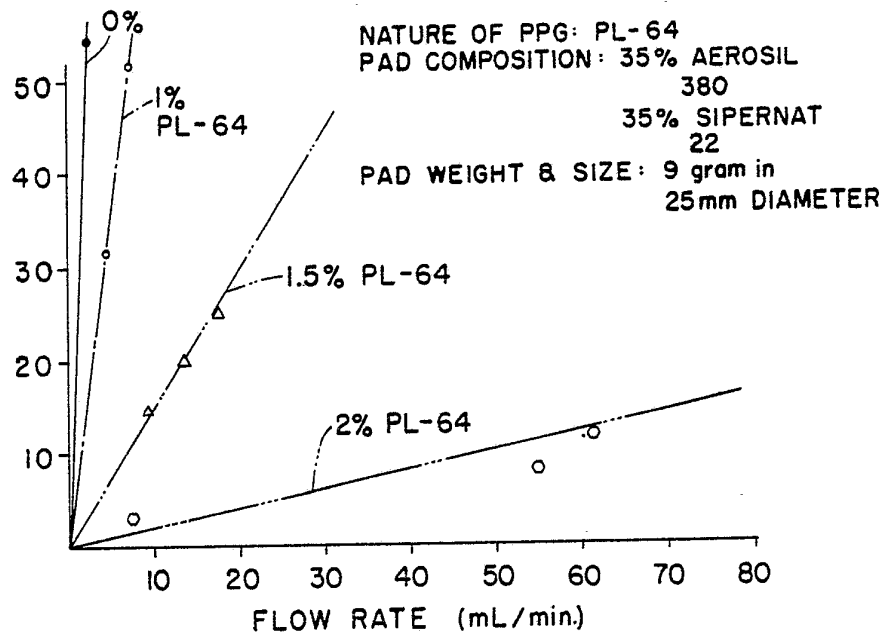

INTERNATIONAL APPLICATION PUBLISHED UNDER THE PATENT COOPERATION TREATY (PCT)

(51) International Patent Classification ³ : D21H 3/36	A1	(11) International Publication Number: WO 84/ 00569 (43) International Publication Date: 16 February 1984 (16.02.84)
<p>(21) International Application Number: PCT/US83/01089</p> <p>(22) International Filing Date: 18 July 1983 (18.07.83)</p> <p>(31) Priority Application Number: 401,361</p> <p>(32) Priority Date: 23 July 1982 (23.07.82)</p> <p>(33) Priority Country: US</p> <p>(71) Applicant: AMF INCORPORATED [US/US]; 777 Westchester Avenue, White Plains, NY 10604 (US).</p> <p>(72) Inventor: HOU, Kenneth, C. ; 14 Hunting Ridge Road, South Glastonbury, CT 06083 (US).</p> <p>(74) Agent: ZALL, Michael, E.; AMF Incorporated, 777 Westchester Avenue, White Plains, NY 10604 (US).</p>		<p>(81) Designated States: AU, BR, DK, JP, NO.</p> <p>Published <i>With international search report.</i></p>

(54) Title: FIBROUS MEDIA CONTAINING MILLIMICRON SIZED PARTICULATES



(57) Abstract

A self supporting fibrous matrix containing immobilized therein at least about 5% by weight of microparticulate, with an average diameter less than 1 micron, preferably fumed silica, or alumina, and flocculating amounts of a neutral organic polymeric resin having oxygen atoms along the backbone thereof, is useful for fluid treatment and filtration processes, especially delipidization and depyrogenation of fluids such as serum. Figure 3 shows the effect of flow rate based on varying amounts of polypropylene glycol (PL-63) as the neutral organic polymer in a fibrous matrix containing microparticulate silica (Aerosil 380, Sipernet 22).

FOR THE PURPOSES OF INFORMATION ONLY

Codes used to identify States party to the PCT on the front pages of pamphlets publishing international applications under the PCT.

AT	Austria	LI	Liechtenstein
AU	Australia	LK	Sri Lanka
BE	Belgium	LU	Luxembourg
BR	Brazil	MC	Monaco
CF	Central African Republic	MG	Madagascar
CG	Congo	MR	Mauritania
CH	Switzerland	MW	Malawi
CM	Cameroon	NL	Netherlands
DE	Germany, Federal Republic of	NO	Norway
DK	Denmark	RO	Romania
FI	Finland	SE	Sweden
FR	France	SN	Senegal
GA	Gabon	SU	Soviet Union
GB	United Kingdom	TD	Chad
HU	Hungary	TG	Togo
JP	Japan	US	United States of America
KP	Democratic People's Republic of Korea		

-1-

DescriptionFibrous Media Containing
Millimicron-Sized ParticulatesTechnical Field

The present invention relates to fibrous media containing millimicron sized particulates, especially media containing fumed silica or fumed alumina.

Background Art:

The technique of flocculating negatively charged filter aid particulates or adsorbents and fibers, by means of positively charged polymers is a common practice in the production of filtration media.

For example, Malcolm, U. S. Patent 3,647,684 describes a felted fibrous matrix containing silicic acid (hydrated silica) interdispersed therein, useful for thin layer chromatography wherein the silicic acid has particle sizes within 1 to 10 microns, and which contains a cationic material in concentrations no higher than 1.5%. Ostreicher, U. S. Patents 4,007,113 and 4,007,114 describes a matrix of self-bonding fibers containing interdispersed therein a particulate filter material, the surface of which is modified with an organic colloid. Additional patents relating to fibrous media containing interdispersed particulate material are: Pall et al, U. S. Patent 3,573,158, Leifield, U. S. Patent 3,455,818 and Pall et al, U. S. Patent 3,238,056.

The application of positive charge flocculation techniques for the formation of specialized and improved media has also been described in commonly assigned



-2-

copending U. S. patent application Serial No. 164,797 filed May 30, 1980, now U.S. Patent _____, and in U.S. Patent 4,305,782, and U.S. Patent 4,309,247, which are herein incorporated by reference.

The porous filter media described in these applications are comprised of fiber-particulate and fiber-fiber mixtures, with cationic charge modifiers serving as charge modifiers, wet strength providers and also as flocculating or dispersion agents in the forming slurry system.

The mixtures are formed dynamically into sheets by vacuum felting from an aqueous slurry, and subsequently drying the finished sheets as the final product. The rate of production of such porous filter media is governed by the porosity of the sheets to be produced. A highly open filter media comprising particle sizes of 50 microns or larger requires only a few seconds to be felted, whereas a tight media utilizing particle sizes of 1-2 microns or smaller would require more than 5 minutes to be felted. Sometimes, media containing the finest grades of particulate additives cannot be felted at all due to improper flocculation. Therefore, it is impossible to form a fibrous media with adsorbent particles less than 1 micron by current techniques. Moreover, the retention of such small size particles in the matrix structure is a serious problem. Most of them are lost to the water drainage during felting.

The limitations and drawbacks involved in current fibrous media manufacturing processes can be understood from the following method of formation. The application of vacuum for the formation of fibrous media is predominantly a hydromechanical process. A slurry containing all the components drains through a 100 mesh wire screen perpendicular to the plane of the screen, and



drags all the components with its movement during felting. Large fibers which have the largest surface area in contact with water of any of the components in the slurry, receive the strongest viscous drag force and settle ahead of others to form a bottom fibrous network. This process provides a self-adjusting mechanism for uniform distribution of particles and fibers in the fibrous structure, based upon the fact that the drainage flow always seeks the path of least resistance. While the large fibers are preferentially retained during the initial deposition, smaller fiber fragments tend to migrate through the fiber mat of long fibers and become lodged in the interfiber holes, to provide a coherent mat structure for adsorbent particles to settle in. Continuous application of vacuum after sheet forming, induces mat compaction. The compacting force exerted by the high vacuum, further squeezes water molecules out of the wet pad, and forces adsorbent particles closer together to form a pad with definite porosity.

The above described method, however, is applicable only to particles larger than about 1 micron. In the case of particle sizes less than 1 micron, especially millimicron sized ones, such particles either fail to be retained by the fiber matrix, or fail to be further felted after forming a thin layer of compact particulate.

In particular, the formation of fibrous mats with a high load of millimicron sized particulate (e.g., higher than about 30% by weight) and with high porosity is near to impossible using the felting techniques of the prior art. Among the millimicron sized particles of great interest for commercial chemical and biochemical applications is fumed silica.

The removal of lipids through adsorption on silica



is a common practice in chemistry and biochemistry. See e.g. Stephan, U.S. Patent 3,686,395 and commonly assigned copending U.S. Patent Applications Serial Nos. 238,686 filed February 27, 1981, and its C.I.P., S.N.349,691, filed February 17, 1982, to Carpenter and Cone entitled TISSUE CULTURE MEDIA. The efficiency of lipid removal by silica differs with the process by which the silica is made. Silicas precipitated from the vapor phase are better lipid removal agents than those precipitated from sodium silicate solutions. Typical commercial products of silicas made from vapor phase are Cab-O-Sil®, Aerosil® (Degussa) or Sipernet 22S®. These products exist in minute particles having average diameters from 7 to 18 millimicrons (or nano-meters). They are produced by the hydrolysis of silicon tetrachloride vapor in a flame of hydrogen and oxygen. At a flame temperature of 1270°K the vapor pressure of SiO₂ is only 10⁻⁸ Torr, so that there is a very high supersaturation, resulting in large numbers of small nuclei forming silica spheres with diameters ranging from 7 to 18 millimicrons on the average. These molten spheres, termed primary particles, collide and fuse with one another to form branched, three dimensional, chainlike aggregates. During the hydration of fumed silica, hydroxyl groups become attached to some of the silicon atoms on the particle surfaces. This makes the fumed silica surface hydrophilic, and capable of hydrogen bonding with other molecules.

Fumed silica is fluffy and low in density (approximately 2 lbs. per cu. ft.). Even a small amount of fumed silica packed in a column will create extremely high pressures upon contact with buffer solutions, due to the formation of a three dimensional network among the particles, with water molecules functioning as bridges. When prior art methods of dispersal of particulates in fibrous media are applied to fumed silica, the previously



mentioned problems of fabrication, retention and porosity are observed.

Fumed silica - albeit not in immobilized form - has been used for the removal of hepatitis B surface antigen from fluids e.g. Stephan U.S. Patent 3,686,395. Other methods of removing viruses from fluids are taught in Porath et al U.S. Patent 3,925,152, Andersson et al U.S. Patent 4,168,300, Wallis et al U.S. Patent 3,770,625, Vnek et al U.S. Patent 3,951,937 and Bick et al U.S. Patent 4,057,628. None of these references uses or suggests immobilized inorganic adsorbants.

At this point it is worth mentioning commonly assigned U. S. Patent No. 4,228,462 to Hou and Ostreicher for METHOD FOR REMOVING CATIONIC CONTAMINANTS FROM BEVERAGES, which describes a method for preparing a filter sheet having anionic electrokinetic capture potential, which comprises cellulose pulp, particulate filter aids, an inorganic cationic surface charge modifier and an inorganic anionic charge modifier, wherein the charge modifiers are cationic and anionic colloidal (inorganic) silicas respectively. Among the particulate aids are mentioned diatomaceous earth, perlite, talc, silica gel, etc., having a high surface area, and being preferably siliceous materials such as the finer grades of diatomaceous earth and perlite. The reason for utilizing the anionic charge modifiers, however, is to provide high electrokinetic capture potential for positively charged fluid contaminants. Further, the reason for using inorganic (rather than organic) charge modifiers is so as to prevent the possibility of extracting organic elements into the filtrate. No solution is offered for the production of microparticulate-containing fibrous media.

In. U.S. patent application S.N. 347,360, filed on



February 9, 1982, by the present inventor, for FIBROUS MEDIA CONTAINING MILLIMICRON-SIZED PARTICULATE there is offered one solution to the problem of dispersing small sized particulate in a fibrous media. The method used therein comprises adding to the fiber slurry flocculating amounts of an organic polycationic and an organic polyanionic resin.

A need exists for other methods of homogeneously immobilizing particulate materials having millimicron sized average diameters, especially fumed silica, into fibrous matrices. A need also exists for the products produced by such method.

Disclosure of the Invention

It is an object of the invention to provide fibrous media containing millimicron-sized particulates immobilized therein.

It is another object of the invention to provide a method for the production of fibrous media containing millimicron sized particulates immobilized therein.

Yet another object of the invention is to provide fibrous materials containing fumed silica and/or alumina immobilized therein.

Still another object of the invention is to provide a method for the production of fibrous media containing fumed silica dispersed therein.

Another object of the invention is to provide for a method of removal of HBsAg from fluids by using immobilized fumed silica, and a method of removal of pyrogens from fluids by using immobilized alumina.

These and other objects of the invention, as will hereinafter become more readily apparent have been attained by providing:



A self supporting fibrous matrix, preferably a sheet, containing immobilized therein, at least about 5% by weight of microparticulate material having an average diameter less than 1 micron, and a neutral organic polymeric resin having oxygen atoms along the polymeric backbone thereof, wherein said resin is present in an amount effective to flocculate said microparticulate in said matrix.

The objects of this invention have also been attained by providing:

In a method of fabricating a self-supporting fibrous matrix containing particulate material, the improvement wherein said material has an average diameter less than 1 micron and wherein said fabrication is carried out in the presence of flocculating amounts of a neutral organic polymeric resin having oxygen atoms along the polymeric backbone thereof.

Brief Description of the Drawings

A more complete appreciation of the invention and many of the attendant advantages thereof will be readily obtained as the same becomes better understood by reference to the following detailed description when considered in connection with the accompanying drawings, wherein:

FIGURE 1 shows the variation of felting time of silica containing filter sheets containing various amounts of polyalkylene glycol pluronic PL-62® S-22 is Sipernet 22®, and 380 is Aerosil 380®;

FIGURE 2 shows the variation of felting time of the silica containing filter sheets of FIGURE 1 containing various amounts of two different polyalkylene glycols pluronics PL-62® and PL-64®;

FIGURE 3 shows the effect of polypropylene glycol



PL-64® on the medium porosity, determined by plotting pressure vs. flow rate. Filter composition = 35% Aerosil 380®, 35% Sipernet 22® and various amounts of PL-64® (0, 1.0, 1.5 and 2%);

FIGURE 4 shows the effect of two different polypropylene glycols (PL-62® and PL-64®) on filter pad porosity, under the same conditions as in FIGURE 3;

FIGURE 5 shows a vacuum felting device used to measure felting times of silica-containing fiber slurries; and

FIGURE 6 shows a typical separation column using, as separation material, the fibrous media of the invention in the form of discs.

Best Mode for Carrying Out the Invention

The present invention is based on the discovery that fabrication of self-supporting fibrous media containing millimicron sized particulate material ("micro-particulates") is greatly facilitated by addition to the forming slurry of a neutral organic polymeric resin having oxygen atoms along the polymeric backbone thereof. Unless this resin is present in the slurry of fibers and micro-particulate material, the microparticulate material on the one hand fails to be flocculated or on the other hand, reaches a stage where a water impermeable gel-like structure is formed, both of which prevent felting; the vacuum felting of the slurry is severely hampered, and the micro-particulates fail to be retained by the fibrous matrix.

As a result of this discovery it is possible to prepare self supporting fibrous matrices, especially fibrous sheets, containing high loads of micro-particulates without fear of loss of micro-particulates during production, or subsequent liquid purification and



filtration operations.

By "self-supporting fibrous media" is meant to include any coherent matrix of fibers which will maintain its shape and form when in the dry state, i.e., will not fall apart. In its most common form the self-supporting fibrous media is a sheet made from at least one component which is a long, self-bonding structural fiber, to give the sheet sufficient structural integrity in both the wet "as formed," and in the final dried condition, and also to allow handling during processing and suitability for the intended end use. The matrix has two external faces and a substantially homogeneous cross-section therebetween. This means that the cross sectional area does not show any abrupt structural discontinuities, as would be seen if the matrix was layered or internally compartmentalized or divided in any way. The matrix comprises both fibers and particulate, but these two different materials are so intimately interdispersed that the cross-section from face to face has the same appearance throughout.

Cellulose fibers such as wood pulp, cotton, cellulose acetate or rayon can be used. These fibers are typically relatively large, with commercially available diameters in the range of six to sixty micrometers. Wood pulp, can also be used, and has fiber diameters ranging from fifteen to twenty-five micrometers, and fiber lengths of about 0.85 to about 6.5 mm.

Other fibers which can be used include polyacrylonitrile fibers, nylon fibers or polyvinylchloride fibers. The preferred fibrous matrix of the invention is a porous self-bonding sheet of cellulose fibers.

The long self-bonding structural fibers are preferably obtained from normally dimensioned cellulose



-10-

pulp such as manila hemp, jute, caroa, sisal, bleached or unbleached kraft, kozo and the like, which typically has a Canadian Standard Freeness of +400 to +800 ml. These long self-bonding fibers will constitute greater than 50% of the porous matrix, by weight, preferably about 66-90% of the porous matrix, and most preferably 75-83%.

When the amount of micro-particulate immobilized in the porous matrix is low, i.e., less than about 50% by weight of the media, it is preferred that the porous matrix be formed of a self-bonding matrix of normal cellulose pulp having a Canadian Standard Freeness of +400 to +800 ml.

In the preferred embodiment of this invention it is desirable to have a high amount of micro-particulate, i.e., greater than about 50% by weight of the medium immobilized in the porous matrix. It is thus desirable to use the method described in commonly assigned U.S. Patent 4,309,247, to Hou et al to maintain such high content of micro-particulate in the matrix. The entire disclosure of this patent is incorporated herein by reference. Broadly, a minor portion of cellulose pulp refined to a Canadian Standard Freeness (CSF) of between about +100 and -600 ml is incorporated with a major portion of the normally dimensioned cellulose pulp (+400 to +800 ml). In particular, from about 1% to about 10% of the refined pulp and about 10% to about 30% of the normal cellulose pulp, by weight of the medium, is contained in the matrix, the remainder being the particulate. Generally, the weight ratio of unrefined to highly refined pulp will range from about 2:1 to about 10:1, preferably 3:1 to about 5:1. Such a mixture of pulps permits the increased retention of the fine particulates of the invention.

By "particulate" material is meant to include any



adsorbent or particulate used in the molecular separation art for some time such as those disclosed in the following U. S. Patents, which are herein incorporated by reference: 2,143,044; 2,746,608; 3,238,056; 3,253,978; 3,591,010; 4,007,113; 4,160,059; 4,238,334; 3,669,841; 3,722,181; 3,795,313; 3,983,299; 4,029,583; 3,664,967; 4,053,565 and 4,105,426. Among the useful particulate is fumed silica, fumed alumina, microcarbon, inorganic salts, and various mixtures thereof. The particulates include those which can serve as support for further chemical modification of the particles. In the present invention at least some of the particulate material has on the average a diameter of less than 1 micron; i.e., a Gaussian distribution of particle diameters will have a maximum at less than 1 micron and is therefore termed "micro-particulate". Those sizes wherein this invention is most useful are less than 100 millimicrons, most preferred less than 50 millimicrons, especially between 1 and 25 millimicrons. In the preferred embodiment of the invention, the microparticulate is fumed silica or fumed alumina. As described previously, the term fumed silica includes materials made from the hydrolysis of SiCl_4 vapor in a flame of hydrogen and oxygen, and have diameters between 5 and 20 millimicrons. Fumed alumina includes aluminum oxide produced by flame hydrolysis of anhydrous aluminum chloride (e.g. Aluminum Oxide C from Degussa).

Generally the micro-particulate is present in the matrix in weights of at least about 5%, preferably 20-90% by weight, preferably about 70% by total weight. It is possible to use as immobilized particulate a mixture of microparticulate (average diameter less than 1 micron), with coarser particulate (having average diameter larger than 1 micron) in any ratio, preferably 5-95 parts by weight of micro to 95-5 parts of coarse particulate



-12-

ratio; the total particulates content would then be within 5-90%, as before.

The critical aspect of the invention is the presence in the matrix of a neutral organic polymeric resin. This resin flocculates the microparticulates and increases their retention in the matrix. By "organic" is meant that the polymeric backbone is composed predominantly from carbon and oxygen atoms, and maybe also other elements normally present in organic structures such as nitrogen, sulfur and occasionally phosphorous. By "polymeric" is meant that the resin is composed of a plurality of repeating units. Typical molecular weights are 500-1,000,000 or more preferably 1000-50,000. By "neutral" is meant that the polymer contains or carries no cationic or anionic charges. Such resins are described for example in Jackson et al, U.S.P. 2,677,700; Lundstedt, U.S.P. 2,674,619 or Patton, Jr., U.S.P. 2,786,080, all of which are herein incorporated by reference.

Typical neutral polymers within the scope of the invention are those having the formula (I)



wherein R_1 , R_2 , R_3 and R_4 are the same or different and selected from the group consisting of hydrogen, or lower alkyl (C_1 - C_5 alkyl), and n is adjusted according to the desired molecular weight. These include all polyalkylene oxides such as polyethylene oxide, polypropylene oxide, and the like. Homopolymers as well as random or block copolymers of different polyalkylene oxides can be used. These copolymers may be represented by formula (II):

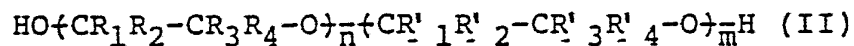

where n and m are adjusted as before and R'_1 , R'_2 , R'_3 and R'_4 are as defined for R_1 - R_4 , supra.



For example, polyethylene oxide produced by Union Carbide under the trade name of Polyox®, polyethylene glycol produced by Union Carbide under the trade name Carbowax®, Jeffox® by Jefferson Chemicals, polyglycol E® by Dow Chemical, and Pluracol E® by BASF can all be used.

Preferably, polyoxypropylene block co-polymers with polyoxyethylene sold under the trade name of Pluronic Polyols by BASF Wyandotte Corporation of Parsippany, N.J. are used. These co-polymers are formed by the condensation of propylene oxide onto a propylene glycol nucleus followed by the condensation of ethylene oxide onto both ends of the polyoxypropylene base. Depending upon chain length and % polyethylene units in total molecule, they range in physical form at room temperature from water white viscous liquids, through waxy semisolids, to hard waxlike solids. These series of co-polymers may be represented by the empirical formula (III)

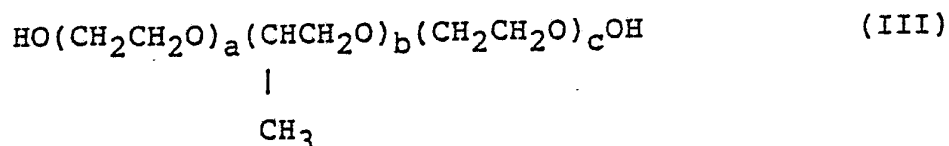

In the most preferred mode, an average molecular weight of 1750 with different ratios of polyoxyethylene (a + c) to propylene glycol (b) is used. Pluronic L62® contains 20%, and pluronic L64® contains 40% polyoxyethylene respectively.

The variables for the fibrous media of the invention, which have influence on the fabrication and final properties of the media are:



-14-

- 1) Type of fiber or fibers used;
- 2) Length to diameter (L/D) ratio of each type of fiber;
- 3) % weight of fiber in the mixture;
- 4) % weight of neutral polymer in the mixture and its ratio to microparticulates;
- 5) Type and % weight of microparticulate in the mixture;
- 6) Type of resins utilized;
- 7) Type of solution used for slurry (water, alcohol, solvent) to form the matrix, and pH thereof;
- 8) Slurry additives (wetting agents, impurities, etc);
- 9) Conditions of microparticulate flocculation; and
- 10) Felting conditions.

The more relevant of these which have not already been described supra, will be discussed as a guide, and further details can be obtained from the Examples. However, the adjustment of the aforementioned variables as well as their interrelationships can be readily ascertained by those skilled in the art, without undue experimentation, depending on the type of utility desired for the final media.

The total amount of neutral polymer is that sufficient or effective to flocculate the microparticulate present in the medium, but insufficient to form an impermeable gel which would prevent slurry felting. Normally the amount can be from 0.5 to 15% of the total weight of fibrous media, preferably 1 to 3%.

The self supporting fibrous matrix of the invention is preferably made by vacuum-felting an aqueous slurry of fibers, resins and particulate. This forms a sheet having the particulate immobilized in a porous matrix. The sheet shows a uniform high porosity, fine pore-size



-15-

structure with excellent flow characteristics and is substantially homogeneous with respect to the fiber, resins and particulate.

The vacuum felting is performed on a foraminous surface, normally a woven wire mesh which, in practice, may vary from 50 mesh to 200 mesh, with mesh openings ranging from 280 micrometers to 70 micrometers respectively. Finer meshes are unsuitable because of clogging problems and/or structural inadequacy.

The size of the openings in the foraminous vacuum felting surface, and the pore size of the cellulose fiber matrix of the formed sheet, are quite large in comparison to some or all of the dimensions of the fine fiber or particulate components required to produce the desired submicronic filter media sheet.

Application of neutral polymer to the micro-particulates can be performed in the following different modes:

- a) Coating of microparticles in a pre-slurry with the polymer, and adding the coated microparticles to the final slurry; or
- b) Adding the polymer to the microparticles in the final first.

The sequence of adding the overall components to the slurry (i.e., fibers, other particulates, flocculated microparticulates) appears to be relatively unimportant, provided that the slurry is subjected to controlled hydrodynamic shear forces during the mixing process. In the "mixed fiber" embodiment, for example, the refined pulp is added to a slurry of the unrefined pulp and then the flocculated or unflocculated particulate is incorporated therein. The slurry is normally prepared at about 4% consistency and then diluted with additional water to the proper consistency required for vacuum-



felting and sheet formation. This latter consistency will vary depending upon the type of equipment used to form the sheet. Typically the slurry is cast onto a foraminous surface, vacuum felted, and dried in the conventional manner. The flat, dimensionally stable sheet can be of any desired thickness and is then cut to the appropriate dimensions for each type of application.

It is possible to add varying amounts of a polycationic resin or a polyanionic resin to the slurry, if it is desired to achieve increased binding of overall negative or positive charges on the final fibrous media. The addition of a binding amount (0.5-15%, preferably 1-3%) of a polycation such as Polycup 1884® (polyamine polyamide) is preferred.

The best procedure of fabricating a silica containing media is as follows:

1. Dispersing cellulosic fiber of large diameter (20 microns or up) in water at 1-2% consistency;
2. Preparing refined pulps by fiberlating cellulose with a double disc fiberizer or other mechanical means to create fibers of different small sizes;
3. Adding the refined pulp into the dispersed large cellulose fibers to form a cellulosic slurry of different fiber diameters;
4. Adding 0.5 to 1.0% of a binder resin such as polycup 1884® (from Hercules) into the cellulosic slurry to be absorbed on the fiber surface;
5. Adding small sized fumed silica such as Aerosil 380® to the slurry such that the milli-micron sized particle will be absorbed on the fiber;
6. Adding a relatively large sized silica



-17-

- particulant such as Sipernet 22;
7. Adding pluronic PL-62® to disrupt the hydrogen bonding force between the water molecules and the milli-micron sized silica absorbed on fiber surface. This force of disruption controls the porosity and felting time as shown from the data; and
 8. A small amount of resin 1884® (0.1 to 0.5%) can be added as final means of adjustment depending upon the formulation.

The fibrous media of the invention containing micro-particulate can be used in a myriad of applications wherever the free microparticulate would be used, with the advantage of solid phase immobilization.

In particular, the media can be utilized in the filtrations described in aforementioned U.S. Patents 4,305,782, 4,309,247 and U.S. Application Serial Number 164,797 filed May 30, 1980.

The media can be preferably used in the molecular separation (e.g., chromatographic) processes disclosed in copending, application to Crowder U. S. Serial Number 287,609 filed July 28, 1981 for MOLECULAR SEPARATION COLUMN AND USE THEREOF herein incorporated by reference. The media can also be used in preparation of zero standard serum, as that disclosed in copending U. S. Application Serial No.276,982, filed June 24, 1981 for PROCESS FOR PREPARING A ZERO STANDARD SERUM, herein incorporated by reference. A highly preferred use of fumed silica-containing media, is in the delipidization of biological fluids, such as for example of serum, disclosed in copending U. S. Application Serial Number 238,686 filed February 27, 1981 and its C-I-P, filed February 17, 1982 for TISSUE CULTURE MEDIUM, both herein incorporated by reference.



-18-

Another use for the fumed-silica containing media is in the removal of lipid enveloped viruses, for example hepatitis B surface antigen (HBsAg) from fluids, especially biological fluids, especially serum. Still another use is for removal of mycoplasma from fluids. Immobilized fumed alumina can be used for the removal of pyrogens, endotoxins, and the like.

Because conventional techniques of flocculating particles in a fiber matrix by cationic polymers suffer from the limitation that the particles have to be one micron or larger, vacuum felting fails to form media with porosity adequate for fluid flows for filtration or molecular separation. Particles of milli-micron sizes such as fumed silica cannot be flocculated to form a pad, due to hydrogen bonding forces exerted between the minute particles. This is especially so when the pH of the slurry is not neutral, causing possible ionization of the particles, as evidenced by increases in slurry viscosity.

The present invention provides a specific way to resolve these technical problems by adding a neutral organic polymeric resin to the system.

Several advantages have been noted by the novel approach of the invention.

- 1) The use of mixed fibers provides fine tuning and better control in addition to flocculating interaction of particles with polymer;
- 2) The discovery of this technology not only provides means of encapsulating any small size particles into fibrous structures, but can also speed up the production rate by cutting down on the felting time. Since the prime criteria for a high efficiency molecular separation requires high surface area, which



can be achieved by incorporating therein particles of relatively small size, this discovery offers a unique way of making high efficiency molecular separation;

3)The use of neutral polymers results in fibrous media with highly open porosity, in some instances higher porosity than that obtainable with the polysalts of S.N. 347,360, filed February 9, 1982. The optional addition of polyelectrolytes, moreover, can additionally confer on the media either cationic or anionic character, depending on the type of polyelectrolyte added in excess;

4)The chemical nature of the neutral polymer is biocompatible and closely resembles body tissues, such as collagen. The complex is very permeable to water, which makes the material an ideal binder for filters in bio-applications;

5)The neutral polymer is also a superior retention aid for the fibrous media, judging from the amount of fumed silica retained in a pad structure, and as an excellent wet strength provider shown from the testing results later described herein.

Having now generally described this invention the same will become better understood by reference to certain specific examples which are included herein for purposes of illustration only and are not intended to be limiting unless otherwise specified.



-20-

Example 1Preparation of Cellulose Based Media
Containing Fumed Silica ParticulateI. General

Large cellulosic fibers (+400 to +800 CSF) were dispersed to a 1% solids content in a water slurry. After complete dispersion, short fibrillated cellulosic fiber (+40 to -10 CSF) was added to the slurry to a 3.5% consistency. This was followed by addition of the fumed silica (Aerosil 380®, 7 millimicrons), silicas of relatively larger sizes (such as Sipernet 22®), binding resin (Polycup 1884®), and neutral polymer (PL-62® or PL-64®).

Sufficient agitation and mixing was allowed at every stage of addition. The mixture was pumped through a 100 mesh screen vacuum forming pot, and the filter pad was formed upon the application of vacuum to decant the water. The time required for the disappearance of water inside the pot after the application of vacuum is defined as the felting time. The smaller the particle sizes in the slurry, the longer the felting time to form the filter pad.

A device for the measurement of the felting time is shown in FIGURE 5, where a filter fabricating tank 1, is shown in cross section, containing slurry 2 in container 3, which is snugly positioned by means of rubber gasket 4, and O-ring 5 on support 6 holding a 100 mesh screen, whereupon is formed the final filter. By applying vacuum through vacuum pump 7, water from the slurry is forced through the screen and drained into drainage tank 8, where it can later be retrieved through valve 9.

The filter fabricating tank was made of a 5 inch diameter-polypropylene cylinder and a slurry containing all the components at 1% consistency was drawn through



the cylinder. The length of time required to form the wet pad after applying 25 inch vacuum through the device was recorded as the felting time. For convenience and economics of production, the felting time for the filter should ideally be less than 10 minutes.

Tables 1 and 2 show the media made by this process, as well as the felting times.



TABLE I

Filter #	Large Cellu- losic Coho (%)	Short Micro- flake (%)	Aerosil 380® (%)	Particulate Sipermet 22®(2) (%)	Binding Resin Poly- cup 1894 (%)	Polyalkylene Glycol (PL-62) added (%)	Felting Time (Min.)	Pad Weight (g)
1	20	10	35	35	18	0	unable to form	14.0
2	20	10	35	35	18	0.8%	2.0	15.0
3	20	10	35	35	18	1.0%	1.0	15.5
4	20	10	35	35	18	2.5%	1.5	16.0
5	20	10	35	35	18	5.0%	2.0	14.5
6	20	10	35	35	18	7.5%	3.2	14.5
7	20	10	45	25	18	0.9%	2.5	13.0
8	20	10	45	25	18	1.0%	2.0	14.0
9	20	10	45	25	18	2.5%	4.0	15.0
10	20	10	45	25	18	5.0%	10.0	15.0



TABLE 2

Filter #	Large Cellu- losic Coho (%)	Short Micro- flake (%)	Aerosil 380® (%)	Particulate Sipernet 22® (%)	Binding Resin Poly- cup 1884 (%)	Type & Amount Polyalkylene Glycol added (%)	Felting Time (Min.)	Pad Weight (g)
11	20	10	35	35	1.0	0.0 (1)	unable to form	
12	20	10	35	35	1.0	0.5(1)	12.0	14.0
13	20	10	35	35	1.0	1.0(1)	1.0	15.0
14	20	10	35	35	1.0	2.5(1)	1.5	15.5
15	20	10	35	35	1.0	5.0(1)	2.0	16.0
16	20	10	35	35	1.0	0.5(2)	unable to form	
17	20	10	35	35	1.0	1.0(2)	7.0	15.0
18	20	10	35	35	1.0	1.5(2)	5.0	16.0
19	20	10	35	35	1.0	2.0(2)	14.0	14.0
20	20	10	35	35	1.0	4.0(2)		

(1) PL-62®

(2) PL-64®



II. Porosity Measurements

The pad porosity is measured by pumping water through a column such as that of FIGURE 6 with a pressure gauge installed in the line and the volume of filtrates collected in a graduated cylinder under different flow rate. The water flow rate pass through the column can be adjusted to about a 100-fold in range. For example, at 10 PSI pressure across the column, a filter pad made from 1% pluronic PL-64® as dispersing agent is quite tight, and only allows 1 mL/min. of flow, yet 2% PL-64® will open up the filter to give more than 50 mL/min. of water flow, as shown in Table 3.

TABLE 3

Filter #	Polyalkylene Glycol Added	Felting Time	Δp (PSI)	
			Across the column	Flow Rate mL/min.)
1	0%			
17	(PL-64) 1.0%	15.0 min.	32	5.0
			52	7.0
18	(PL-64) 1.5%	7.0 min.	14	9.0
			20	14.0
19	(PL-64) 2.0%	5.0 min.	3.0	7.5
			8.0	54.0
12	(PL-62) 0.5%	12.0 min.	15.0	10.0
			40.0	25.0
13	(PL-62) 1.0%	1.0 min.	4.0	15.0
			6.0	37.0



Example 2
Delipidization of Serum Using the
Media of the Invention

I. Preliminary Evaluation of Free Silicas on Lipid
Adsorptivity

To ascertain what type of silica would be the best for lipid adsorption, the adsorption isotherms of lipids in bovine serum by various types of silica were studied, with the results tabulated in Table 4. The Freundlich isotherm was adopted by plotting (X/M) in milligrams of lipids per deciliter of serum adsorbed by one gram of silica vs. (C) the concentration of unadsorbed lipids remaining in the serum. The slope of the line gives the rate of change of the equilibrium relation between adsorption and lipid concentration. The amount of lipid adsorbed by unit weight of specific types of silica is a direct measure of its adsorptive capacity, which in turn gives its available number of active sites for lipid adsorption.

1. Method of Lipid Determination

The amount of lipid in bovine serum was determined by the sulfo-phospho vanillin method by measuring the (pink) color developed at a wavelength of 540 nm, with olive oil serving as a standard.

The Procedure was as follows:

- (1) 10 μ L of H₂O (blank), standard (standard), or serum (unknown), were added to 10 mL test tubes;
- (2) 0.1 mL conc. H₂SO₄ was added to each tube and mixed;
- (3) 11 tubes were placed in boiling H₂O for 10 min. (\pm 1 min.) then cooled in cold H₂O for \approx 5 min;
- (4) 5 mL of the phospho-vanillin reagent was added



-26-

- to each tube, mixed and incubated at 37°C (\pm 2°C) in a H₂O bath for 15 min;
- (5) The tubes were cooled for \approx 5 min. and the A₅₄₀ was measured within 30 min. (Instrument was set on blank).

The reagents were as follows:

- (1) Vanillin reagent: 6 g/L H₂O (1 L vol. flask) (stable for 2 mo. when stored in brown bottle at room temperature);
- (2) Phospho-vanillin reagent: 350 mL of vanillin reagent and 50 mL H₂O to a 2L Erlenmeyer. Add 600 mL conc. phosphoric acid with constant stirring. Store in brown bottle at room temperature;
- (3) Standard: 600 mg olive oil to 100 mL vol. flask. Bring to vol. with absolute ethanol. Store at 4-7°C.

To carry out the adsorption study, the following procedure was performed: The specific amount of silica was measured accurately and added at the vortex point of 1 mL bovine serum under agitation, the tube was then incubated at 37°C for 1 hour and centrifuged at 3000 rpm for 10 minutes to separate the adsorbent from the serum. The amount of lipid left in the serum supernatant was determined with aid of the results tabulated in Table 4.



TABLE 4. Lipid Removal from Bovine Serum by Various Types of Silica

Manufacturer	Nature of Silica Product (size)	M	C	X	% Lipid Removed	$\frac{X}{M}$ (mg/dL) of Lipid Adsorbed/g of silica
		Weight of silica Applied (in grams)	Concentration of Unadsorbed Lipid (mg/dL)	Concentration of Adsorbed Lipid (mg/dL)		
Davidson Chemical	952 silica gel (50 micron)	0	261	0		
		0.15	251	10	4	66
		0.35	241	20	8	57
		0.50	235	26	10	52
Decalite	Perlite 416 (15 micron)	0	306			
		0.15	303	No effect		20
		0.35	300			17
		0.50	298			16
Davidson	Sylold 266 (2 micron)	0	306	0		
		0.15	246	60	19.6	400
		0.35	200	106	34.7	302
		0.50	151	155	50.6	310
DeGussa	Aerosil 380 (7 millimicron)	0	286			
		0.15	166	120	58.0	800
		0.35	73	213	74.4	608
		0.50	44	242	84.6	484
DeGussa	Sipernet 22S (18 millimicron)	0	296			
		0.15	188	108	36.4	720
		98	198		66.9	565
		66	230		77.7	460
Cabot	M-5 (14 millimicron)	0	290			
		0.15	200	90	31.0	600
		0.35	130	160	55.2	457
		0.50	59	231	79.6	462



The results indicate that natural silicas such as diatomaceous earth or perlite show no, or very little, adsorption of lipids. Silica gel is slightly better than the natural silicates. Fumed silica is far better than silica made from solution precipitation processes.

In attempting to carry out batchwise processes with fumed silica one quickly runs into serious problems. Even a small amount of fumed silica packed in a column will create extremely high pressure upon contact with buffer solutions due to the formation of a three dimensional network among the silica particles, with water molecules functioning as bridges.

Using the silica containing media of the invention, however, it is possible to overcome all of these difficulties as shown in the following study of delipidization of human serum.

II. Lipid Removal from Human Serum

Unfiltered human serum having a lipid content of 514 mg/dl was continuously filtered through a plurality of 10 filters stacked in a plastic column of 25 mm diameter with 10 gram of total filter weight. The reduction of lipid concentration is shown in Table 5.



Table 5

Filter Type	Total No. of Filters	Flow Rate	Volume of Serum Filtered (ml)	Absorbance Measured at 540 nm	Conc. of Lipid (mg/dl)	% Lipid Removal
#3 in	10	2ml/min	0	0.14	514	0
Table 1	do	do	100	0.031	197	62
do	do	do	200	0.046	300	41.0
do	do	do	400	0.077	330	36.0
do	20	do	100	0.020	74	85.0
do	do	do	200	0.030	165	68.0



Example 3Pyrogen Removal by Fumed Alumina FilterI. Fumed Alumina:

Fumed alumina with the same particle sizes as fumed silica can be produced by flame hydrolysis of anhydrous aluminum chloride. An example of such product is aluminum oxide C produced by Degussa.

II. Pyrogen Removal by Fumed Alumina Filter

Pyrogens are substances which, when injected into animals, produce fever and other reactions which can result in death. The most common pyrogenic substances are endotoxins, the lipopolysaccharide (LPS) components of gram-negative bacterial organisms. Endotoxins are pyrogens capable of producing febrile reactions in the human body after intravenous doses of as small as 1 ng/kg. The principal method for keeping parenterals free of contaminating bacterial endotoxins is to keep the manufacturing process and all subsequent handling sterile. Because maintaining sterility is difficult in many production processes, a reliable method is needed for removal of endotoxin from an accidentally contaminated product. Asbestos fiber beds can be used to remove pyrogens but their use in the United States is prohibited by Food and Drug Administration regulations.

To evaluate the performance of fumed alumina filters two types of testing procedures were used. The first involved the passage of small volumes of test solution (10-50 mL) through 0.9 cm² disc filters. The test solution was passed through the filters with the aid of a syringe at a constant flow rate. In large volume experiments usually ten liters of test solution was passed through 3.9 cm² filters at a flow rate of 3.05 gal./sq.ft./min. For contamination of the test solutions



-31-

E. coli LPS (obtained from Sigma Chemical Company) was used. Limulus Amebocyte Lysate (LAL) for endotoxin determination was obtained from M.A. Bioproducts. Its sensitivity for endotoxin determination was evaluated for each test solution and was found to be 30 pg/mL for almost all of the test solution.

To determine endotoxin concentration, 0.1 mL lysate was mixed with 0.1 of test sample and allowed to incubate in a small test tube placed in a water bath at 37°C for 1 hr. The formation of a gel that did not collapse upon two 180° inversions of the tube indicated a positive test. A titration of the endotoxin was performed in every challenge to validate the sensitivity and efficiency of the LAL test.

All test samples were assayed both undiluted and at dilutions of 1:2, 1:4, 1:8, 1:16, 1:32 and 1:64, etc. The end point of each test was reached when the specimen sample showed no formation of a firm clot. This end-point dilution was then multiplied by the sensitivity of the LAL to give the approximate value of endotoxin present in the sample. Thus, concentrations of endotoxins in these studies are reported as multiples of end-point dilutions in picograms per milliliter.

Procedure:

Physiological saline (0.9% NaCl) at pH 6.7 solution for Injection was contaminated with the concentration of E. coli endotoxin per ml indicated in Table 6 and filtered through a 13 mm diameter unautoclaved filter installed in a Millipore® holder. In this case, only one filter pad of approximately 18 mm thickness was used for the test. All the filters were pre-washed with 30 ml of test solution by syringe injection.

The filter used for pyrogen removal was fabricated



based on the formulation #3 in Table 1, by replacing Aerosil 380 with fumed alumina to 35% weight. The filter was found capable of reducing endotoxin TO levels less than the assay limit (30 pg/ml) from small volumes, when the concentration of endotoxin ranged from 1,000 to 1,000,000 pg/ml. Results are shown in Table 6.

Table 6

Concentration of Endotoxin (pg/ml)	Endotoxin Concentration in filtrate (pg/ml)		
	Volume passed through filter 10ml	50ml	500ml
1,000	<30	<30	<30
100,000	<30	<30	<30
1,000,000	<30	<30	~60

Example 4Mycoplasma Removal by Fumed Silica Filter

Contamination of cell cultures by mycoplasma is a common problem in tissue culture. The fumed silica filter of the invention can remove mycoplasma very effectively, through an adsorption mechanism.

I. Test method:

Detection of mycoplasma was performed by using a kit purchased from the Flow Laboratories, Inc., McLean, Virginia.

(a) Inoculation

10 mL of bovine serum were mixed with 40 mL broth as liquid medium. The positive controls were resuspended in 10 mL broth as standard. The liquid medium was inoculated on agar plates in 72 hours or when signs of growth appeared.



(b) Incubation

Agar plates were incubated in an inverted position in an atmosphere of 5% CO₂ in N₂ at 35 to 37°C. Additional plates may be incubated aerobically. The liquid medium was sealed and incubated aerobically. There is some question as to the usefulness of aerobic incubation. Certainly most mycoplasmas are isolated under low oxygen and increased CO₂ concentration.

(c) Examination of Mycoplasma Cultures

Mycoplasma colonies will frequently develop within four days of incubation but all agar plates were incubated two-three weeks before being discarded as negative.

II. Filtration procedure:

Filter #3 listed in Table 1 was cut into 25 mm diameter discs, and stacked in a plastic column with 10 filters of 20 gram total weight. The bovine serum was pumped through the column at 1 ml/min of flow with a peristaltic pump.

The filtrates were collected in a fraction collector and inoculated on agar plates to detect mycoplasma by the Flow Lab kit as described above. The mycoplasma plaque assay was counted after two weeks of inoculation. The percentage of plaque reduction is reported as the efficiency on mycoplasma removal by the filter which is proportional to the total weight of filters stacked in the column, as shown in Table 7.



Table 7

<u>Filter type</u>	<u>Volume of serum filtered (ml)</u>	<u>Mean number of Mycoplasma plaques</u>		<u>% plaque Reduction</u>
		<u>Influent</u>	<u>Effluent</u>	
No. 3 of	10	908	0	100%
Table 1.	20	do	20	97.8
Total wt of	40	do	340	62.6
20 gram	60	do	590	35.0
	80	do	690	24.0
	100	do	695	23.5

Filtration Rate = 1 ml/min
 Pressure drop across the column = 30 psi.

Example 5

Removal of Viral Hepatitis by Fumed Silica Matrices

The phenomena of removal of lipids by a fumed silica filter of the invention can also be applied to the removal of virus with lipid envelopes. An example of such is the hepatitis surface antigen in human serum.

The use of fumed silica "Aerosil"® for selective adsorption of lipoprotein from human sera has been investigated by Stephan, supra, who has recommended such treatment for the improvement of storage stability of sera in infusion. HBsAg behaves like normal serum lipoproteins and can be adsorbed very effectively on free Aerosil®. Such treatment, however, can only be performed in small volumes of sera, since it involves high speed centrifugation to precipitate out the Aerosil® particles.

It is also a nuisance to try to remove the traces amount of Aerosil® left in the supernatant. A filter



containing fumed silica for removing HBsAg and lipids makes the process applicable for large volume filtration with minimum protein loss.

I. HBsAg Determinations

HBsAg determinations were performed by Procedure B of Austria II-125 of Abbott Laboratories; a solid phase radioimmunoassay technique to measure HBsAg levels in serum. (See brochure of Abbott Laboratories, Diagnostics Division, entitled "Antibody to Hepatitis B Surface Antigen ^{125}I (Human) Ausria® II-125".) Polystyrene beads coated with guinea pig antibody are supplied in the kit. Patient serum is added and, during incubation HBsAg, if present, is fixed to the antibody. When antibody tagged with ^{125}I is added, it binds to any HBsAg on the beads creating an antibody-antigen-antibody sandwich.

Within limits, the greater the amount of antigen in the serum specimen, the higher the final count rate.

II. Preparation of Serum Samples

Plasma from chronic carriers of HBsAg was obtained from Herman Hospital in Houston, Texas. The patients' plasma was converted to serum by calcium chloride precipitation to remove fibrinogen. Most of the serum samples showed HBsAg over 100 counts per minute which is over the sensitivity range of the Abbott Ausria kit. Dilution with 0.05 M salt phosphate buffer pH 7.2 in the range of 1:5 to 1:10 ratio will bring the counts down to the accuracy region detectable by Abbott kit. It is our general practice to keep the counts around 50-60,000 CPM, with corresponding HBsAg concentration around 0.2 -



0.3 microgram per mL of serum. The diluted serum was stored in a freezer to avoid the decrease of HBsAg through precipitation during the time of storage.

III. Experimental Set-up.

A schematic diagram of a column for serum filtration is shown in FIGURE 6. A peristaltic pump capable of handling ΔP up to 60 psi was used. Ten filters of size 25 mm were stacked in the column. Filters formulated as #3 in Table 1 containing 35% of Aerosil 380 and 35% of Sipernet 22®, and as #8 containing 45% Aerosil 380, 25% of Sipernet 22 were used in the test. Results are tabulated in Tables 8 and 9.



Table 8: EFFECT OF FILTERS ON HBsAg REMOVAL FROM HUMAN SERUM

Sample No.	Filter No.	Nature of Filter	No. of Filters Applied	ΔP Across	Flow Rate	Volumes Filtered	HBsAg Before CPM	HBsAg After CPM	% Removal	No. of Recycles
A	#3 in Table 1	De-lipid	10	5.5	5 ml/min	40 ml.	1650	584	64.6	1
	do		do	4.5	do	do	do	268	83.8	3
	do		do	4.0	do	do	do	236	85.7	6
	do		do	3.0	do	do	do	164	90.0	10
	do		do	3.0	do	do	do	130	92.2	20
B	Same as above	De-lipid	10	5.5	do	do	2650	1517	42.8	1
	2nd Test		do	4.5	do	do	do	512	80.4	3
	do		do	4.0	do	do	do	175	92.4	6
	do		do	3.0	do	do	do	125	95.3	10
	do		do	3.0	do	do	do	108	96.0	20
C	Same as above	De-lipid	10	5.5	do	do	3400	1412	58.5	1
	3rd Test		do	4.5	do	do	do	702	79.4	3
	do		do	4.0	do	do	do	257	92.5	6
	do		do	3.0	do	do	do	151	96.0	10
	do		do	3.0	do	do	do	146	96.0	20



Sample No.	Filter No.	Nature of Filter	No. of Filters Applied	AP Across	Flow Rate	Volumes Filtered	HBsAG CPM		% Removal	No. of Recycles
							Before	After		
A	#8 in Table 1	De-lipid	10	18	5ml/min	40 ml	2800	1540	45	
	"	"	"	15	"	"	"	285	90	3
	"	"	"	14	"	"	253	90	6	
	"	"	"	13	"	"	172	91	10	
	"	"	"	10	"	"	107	96	20	
B	"	"	"	18	"	3700	2132	42		
	"	"	"	15	"	"	1191	68	3	
	"	"	"	14	"	"	745	80	6	
	"	"	"	13	"	"	333	91	10	
	"	"	"	10	"	"	180	95	20	
C	"	"	"	18	"	4850	2769	43		
	"	"	"	15	"	"	1850	62	3	
	"	"	"	14	"	"	1246	77	6	
	"	"	"	13	"	"	480	90	10	
	"	"	"	10	"	"	170	94	20	



Having now fully described this invention, it will be apparent to one of ordinary skill in the art that many changes and modifications can be made thereto without departing from the spirit or scope of the invention set forth herein.



Claims

1. A self supporting fibrous matrix containing immobilized therein at least about 5% by weight of micro-particulate material with an average diameter of less than 1 micron, and a neutral organic polymeric resin, having oxygen atoms on the polymeric backbone thereof; wherein said resin is present in an amount effective to flocculate said microparticulate in said matrix.

2. The matrix of Claim 1 which has two external faces, and a substantially homogeneous cross-section therebetween.

3. The matrix of Claim 1 wherein, said micro-particulate material has an average diameter less than 100 millimicrons.

4. The matrix of Claim 2 wherein, said average diameter is between 1 and 25 millimicrons.

5. The matrix of Claim 1 which contains, in addition, coarse particulate having an average diameter greater than 1 micron.

6. The matrix of Claims 1 or 5 wherein, the total particulate weight is 5-90% by weight of the matrix.

7. The matrix of Claim 5 which contains 5-95 parts of micro-particulate to 95-9 parts of coarse particulate, per 100 parts by weight of total particulate.

8. The matrix of Claims 1 or 5 wherein, said micro-particulate is present as 5-90% by weight of the matrix.

9. The matrix of Claim 6 wherein, the total particulate weight is about 70% of the matrix.

10. The matrix of Claim 1 which comprises at least one component which is a long self-bonding structural fiber.



-41-

11. The matrix of Claim 10, wherein said fiber is unrefined cellulose pulp having a Canadian Standard Freeness of +400 to +800 ml.

12. The matrix of Claim 11 which also comprises highly refined cellulose pulp with a Canadian Standard Freeness of between +100 to -600 ml.

13. The matrix of Claim 12, wherein the weight ratio of unrefined pulp to highly refined pulp is about 2:1 to about 10:1.

14. The matrix of Claim 13, wherein the ratio is 3:1 to about 5:1.

15. The matrix of Claim 1, wherein said neutral polymeric resin is a polyalkylene oxide homopolymer or a block or random copolymer thereof.

16. The matrix of Claim 1 wherein said neutral polymeric resin has the formula

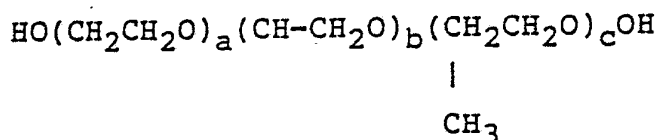

wherein the weight ratio of (a + c) units to total units (a + b + c) varies from 10 to 90% and wherein the total molecular weight is in the range 500 to 1,000,000.

17. The matrix of Claim 16, wherein the weight ratio of (a+c) units to total units is 10 to 50%.

18. The matrix of Claim 16, wherein the weight ratio of (a+c) to total units is 20 to 40%.

19. The matrix of Claim 1, wherein the total amount of neutral organic polymeric resin is 0.5%-15% by weight of the total matrix.

20. The matrix of Claim 1, wherein said microparticulate is fumed silica.



21. The matrix of Claim 1 wherein said microparticulate is fumed alumina.

22. The matrix of any of Claim 20 or 21 which is in the form of a sheet.

23. The matrix of Claim 20, wherein said fumed silica has an average particle diameter of 5 to 20 millimicrons.

24. The matrix of Claim 20 which also comprises coarse siliceous particulate having an average diameter greater than 1 micron.

25. The matrix of any of claims 20 or 24, wherein the total particulate weight is 10-90% of the matrix.

26. The matrix of Claim 25 which contains 5-95 parts of fumed silica to 95-5 parts of coarser siliceous particulate by 100 parts by weight of total particulate.

27. The matrix of Claims 20 or 24 which comprises one fibrous component which is unrefined cellulose pulp having a CSF of +400 to +800 ml; and another fibrous component which is highly refined cellulose pulp having a CSF of +100 to -600 ml.

28. The matrix of Claim 27, wherein the ratio of unrefined to refined pulp is about 2:1 to about 10:1.

29. In a process of fabricating a self-supporting fibrous matrix containing immobilized therein particulate material, the improvement wherein said material is at least about 5% by weight of a microparticulate material having an average diameter less than 1 micron, and wherein said fabrication is carried out in the presence of flocculating amounts of a neutral organic polymeric resin having oxygen atoms in the polymeric backbone thereof.

30. The process of Claim 29 wherein said micro-



particulate has an average diameter less than 100 millimicrons.

31. The process of Claim 30 wherein said average diameter is between 1 and 25 millimicrons.

32. The process of Claim 29 wherein said matrix contains, in addition, coarse particulate having an average diameter greater than 1 micron.

33. The process of Claims 29 or 32 wherein the total particulate weight is 5-90% by weight of the matrix.

34. The process of Claim 29 wherein said matrix comprises at least one component which is a long self-bonding structural fiber.

35. The process of Claim 34 wherein said fiber is unrefined cellulose pulp having a Canadian Standard Freeness of +400 to +800 ml.

36. The process of Claim 35 wherein said matrix also comprises highly refined cellulose pulp with a Canadian Standard Freeness of between +100 to -600 ml.

37. The process of Claim 36 wherein the weight ratio of unrefined pulp to highly refined pulp is about 2:1 to about 10:1.

38. The process of Claim 29 wherein said neutral polymeric resin is polyalkylene oxide homopolymer or a block or random copolymer thereof.

39. The process of Claim 29, wherein said neutral polymeric resin has the formula

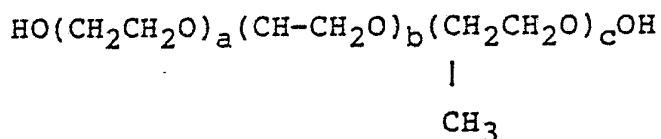

wherein the weight ratio of (a+c) units to total units



varies from 10 to 90% and wherein the molecular weight of the resin is in the range 500 to 1,000,000.

40. The process of Claim 39 wherein the weight ratio of (a+c) units to total units is 10 to 50%.

41. The process of Claim 39 wherein the weight ratio of (a+c) to total units is 20 to 40%.

42. The process of Claim 29 wherein the total amount of neutral organic polymeric resin is 0.5-15%.

43. The process of Claim 29, wherein said microparticulate is fumed silica.

44. The process of Claim 43 wherein said fumed silica has an average particle diameter of 5 to 20 millimicrons.

45. The process of Claim 43 wherein said matrix also comprises coarse siliceous particulate having an average diameter greater than 1 micron.

46. The process of Claim 29 which comprises forming a slurry containing fibrous material, microparticulate material, and flocculating amounts of neutral resin and

vacuum felting said slurry to thereby form said self-supporting fibrous matrix.

47. A process of delipidizing a lipid-containing fluid which comprises contacting said fluid with the fumed silica-containing fibrous matrix of any of Claims 20, 22, 23, 24, 26 or 28.

48. The process of Claim 47 wherein said matrix is in the form of a sheet and said lipid-containing fluid is flowed through said sheet.

49. The process of Claim 47 wherein said lipids in said fluid comprise Hepatitis B Surface Antigen (HBsAg).



50. A process for depyrogenating a pyrogen-containing fluid which comprises contacting said fluid with the fumed alumina-containing fibrous matrix of Claim 20.

51. The process of Claim 50 wherein said matrix is in the form of a sheet and said pyrogen containing fluid is flowed through said sheet.

52. A separation column containing the self-supporting fibrous matrix of Claim 1.

53. The column of Claim 52 wherein said fibrous matrix comprises a plurality of sheets.

54. The column of Claim 53 wherein said sheets are in the form of discs.



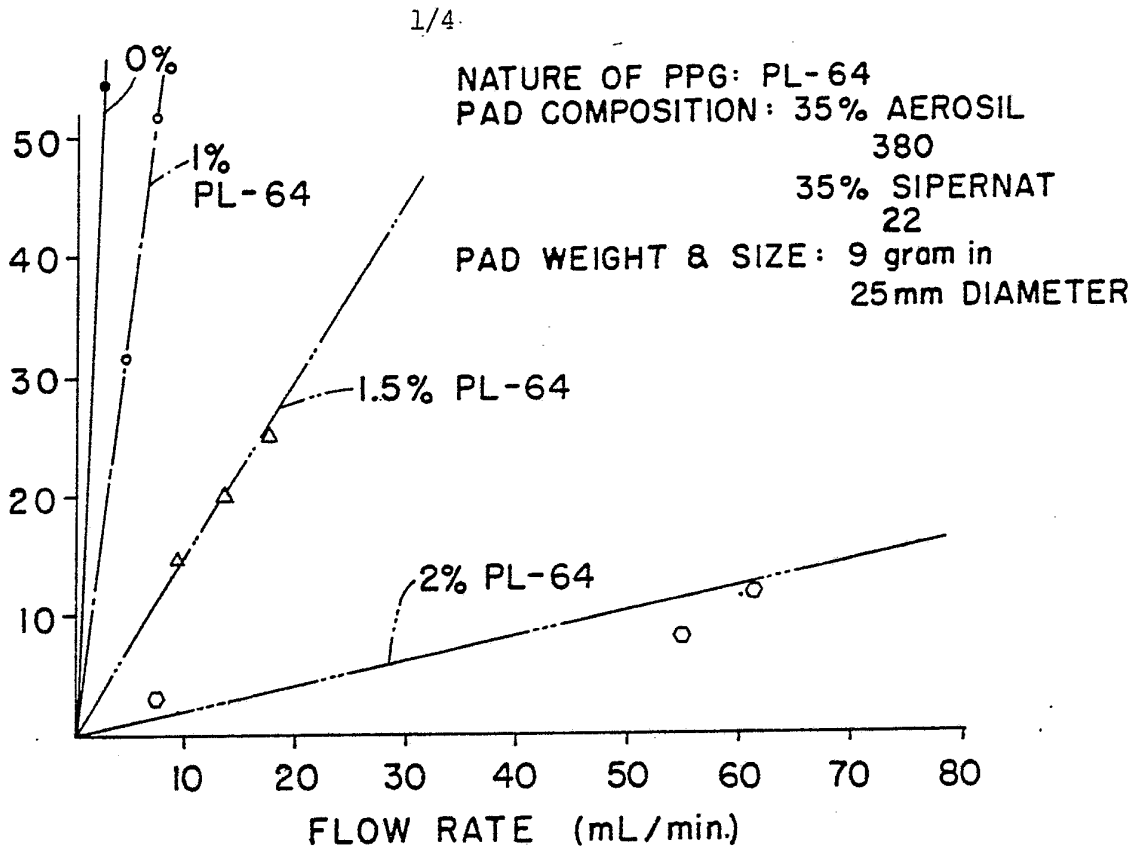

FIG. 3

THE EFFECT OF POLYPROPYLENE GLYCOL ON PAD POROSITY

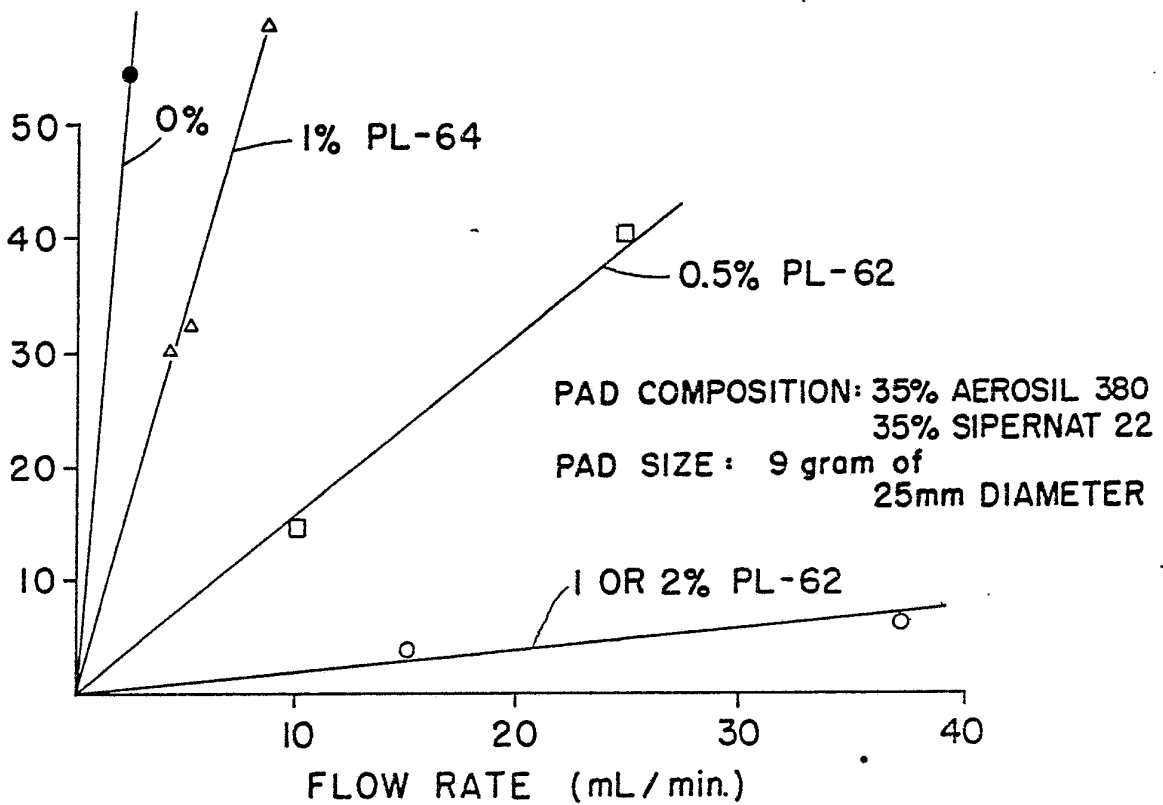

FIG. 4

THE NATURE OF POLYPROPYLENE GLYCOL ON PAD POROSITY

SUBSTITUTE SHEET



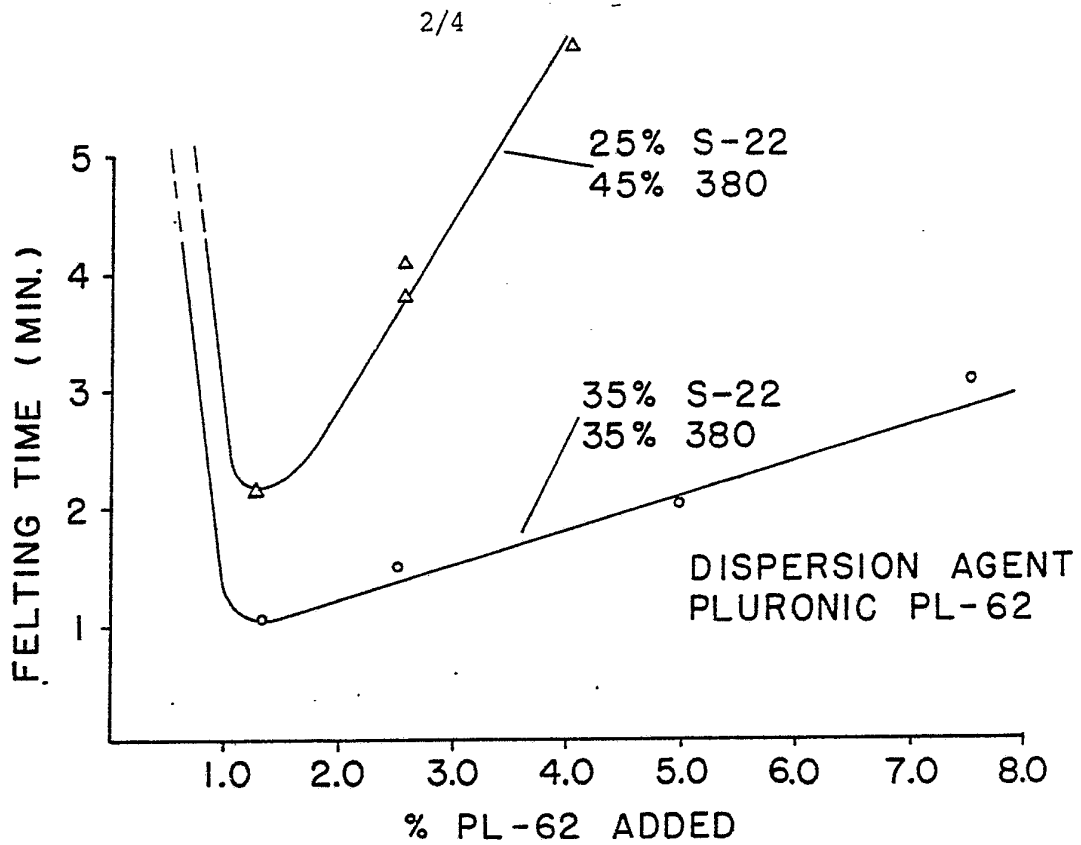

FIG. 1

EFFECT OF PLURONIC POLYOLS ON FELTING TIME

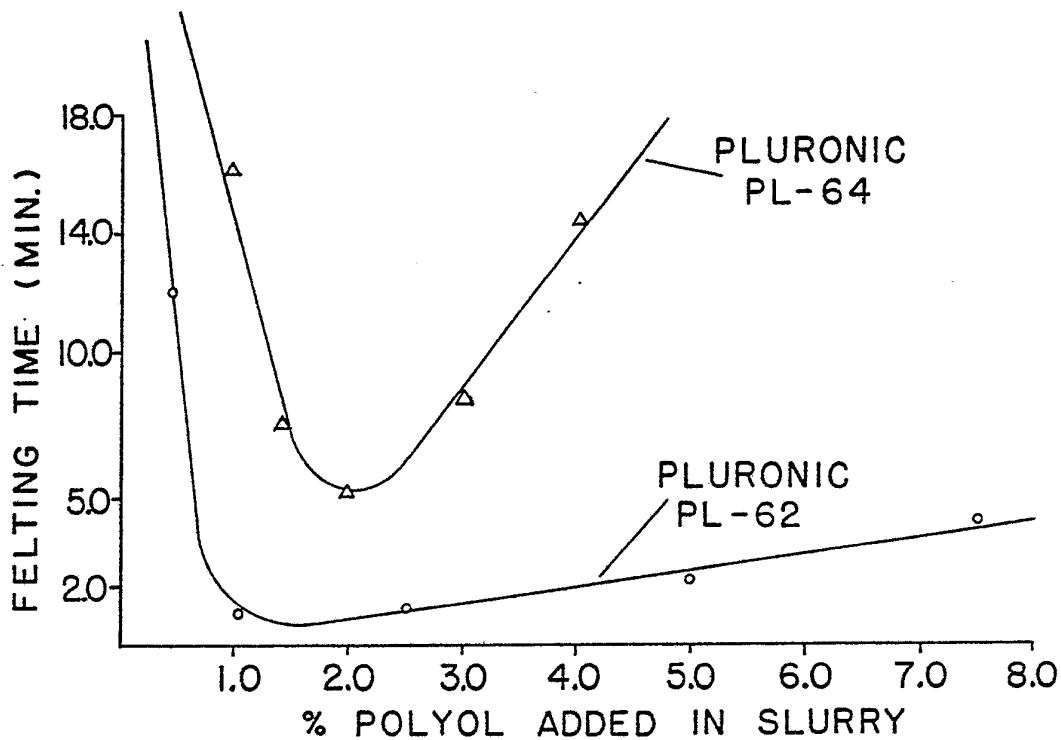

FIG. 2

EFFECT OF NATURE OF POLYOLS ON FELTING TIME

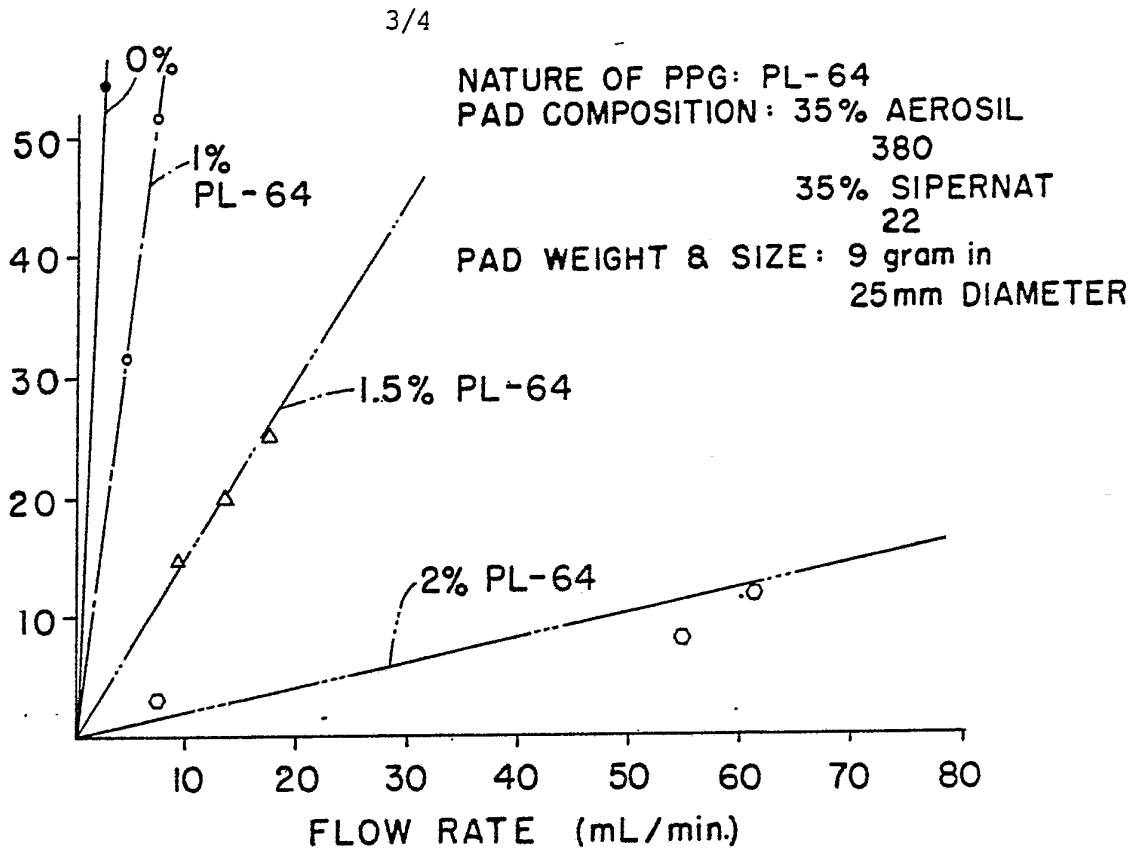

FIG. 3

THE EFFECT OF POLYPROPYLENE GLYCOL ON PAD POROSITY

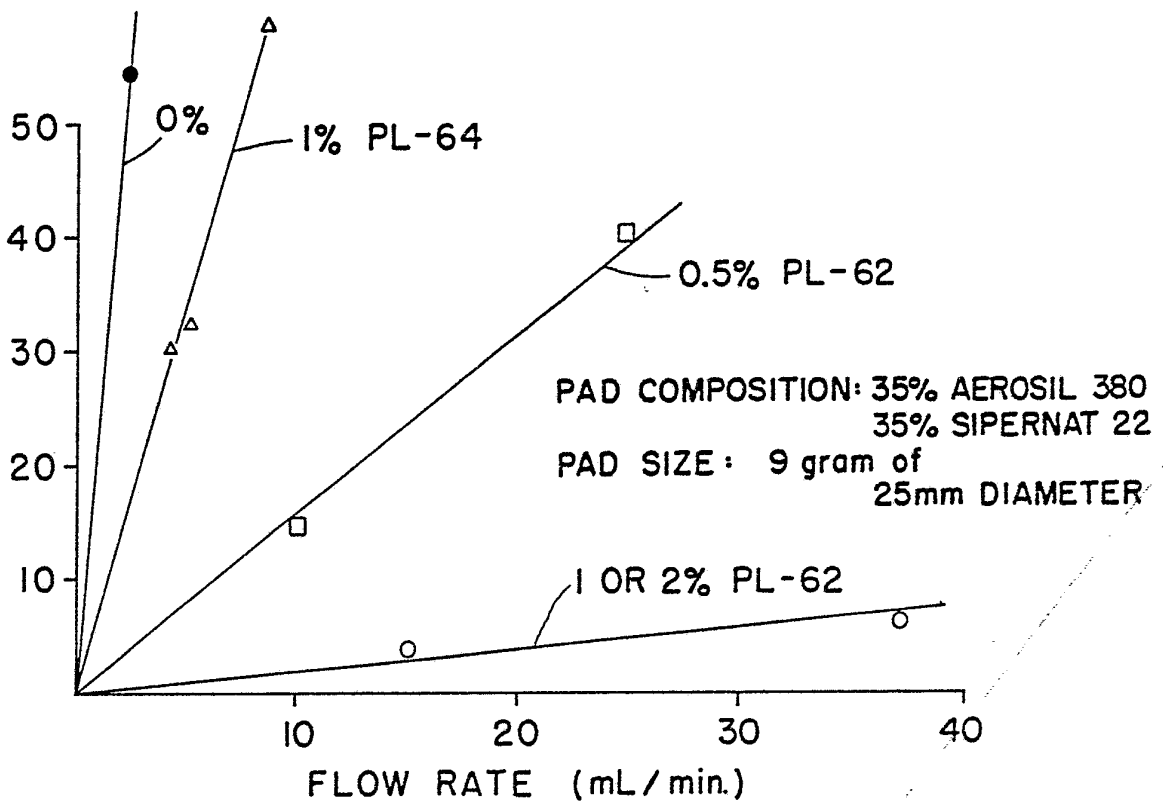

FIG. 4

THE NATURE OF POLYPROPYLENE GLYCOL ON PAD POROSITY

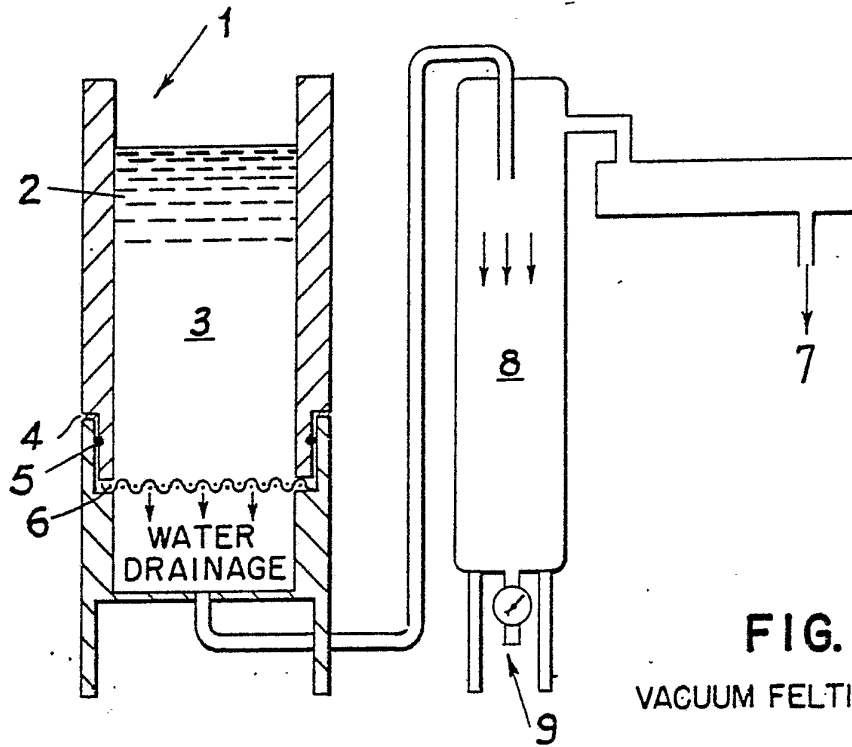

FIG. 5
VACUUM FELTING DEVICE

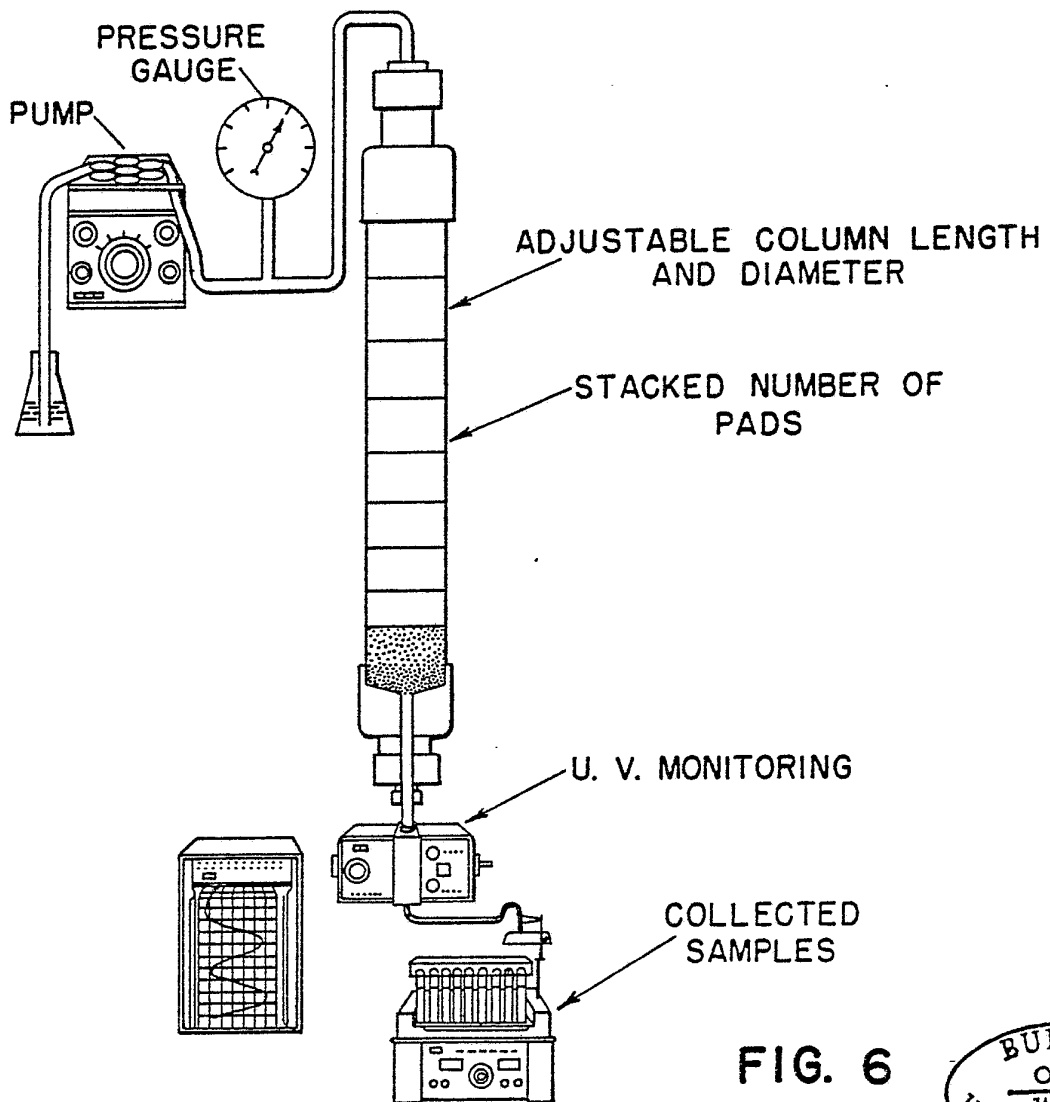
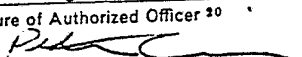

FIG. 6



INTERNATIONAL SEARCH REPORT PCT/US83/01089

International Application No

I. CLASSIFICATION OF SUBJECT MATTER (if several classification symbols apply, indicate all) ³		
According to International Patent Classification (IPC) or to both National Classification and IPC		
INT. CL. ³ D21H3/36		
U.S. CL. 162/164.1		
II. FIELDS SEARCHED		
Minimum Documentation Searched ⁴		
Classification System	Classification Symbols	
U.S.	162/145, 146, 148, 164.1, 168.1, 168.3, 168.6, 169, 181.1, 181.4, 181.6; 210/503, 504, 505, 509, 690; 424/101	
Documentation Searched other than Minimum Documentation to the Extent that such Documents are Included in the Fields Searched ⁵		
III. DOCUMENTS CONSIDERED TO BE RELEVANT ¹⁴		
Category *	Citation of Document, ¹⁶ with indication, where appropriate, of the relevant passages ¹⁷	Relevant to Claim No. ¹⁸
Y	US, A, 3,228,825, PUBLISHED 11 JANUARY 1966 WAGGONER	1-54
Y	US, A, 3,573,158, PUBLISHED 30 MARCH 1971 PALL ET AL	1-54
Y	US, A, 3,253,978, PUBLISHED 31 MARCH 1966 BODENDORF ET AL	1-54
Y	US, A, 4,305,782, PUBLISHED 15 DECEMBER 1981 OSTREICHER ET AL	1-54
Y	US, A, 3,141,815, PUBLISHED 21 JULY 1964 MANLEY	1-54
Y	US, A, 3,266,973, PUBLISHED 16 AUGUST 1966 CROWLEY	1-54
Y	US, A, 4,309,247, PUBLISHED 05 JANUARY 1982 HOU ET AL	1-54
Y	US, A, 3,894,844, PUBLISHED 15 JULY 1975 PINTO ET AL	47-54
Y	US, A, 3,686,395, PUBLISHED 22 AUGUST 1972 STEPHAN	49-51
Y	US, A, 4,073,886, PUBLISHED 14 FEBRUARY 1972 KEHM	47-54
<p>* Special categories of cited documents: ¹⁵</p> <p>"A" document defining the general state of the art which is not considered to be of particular relevance</p> <p>"E" earlier document but published on or after the international filing date</p> <p>"L" document which may throw doubts on priority claim(s) or which is cited to establish the publication date of another citation or other special reason (as specified)</p> <p>"O" document referring to an oral disclosure, use, exhibition or other means</p> <p>"P" document published prior to the international filing date but later than the priority date claimed</p> <p>"T" later document published after the international filing date or priority date and not in conflict with the application but cited to understand the principle or theory underlying the invention</p> <p>"X" document of particular relevance; the claimed invention cannot be considered novel or cannot be considered to involve an inventive step</p> <p>"Y" document of particular relevance; the claimed invention cannot be considered to involve an inventive step when the document is combined with one or more other such documents, such combination being obvious to a person skilled in the art.</p> <p>"G" document member of the same patent family</p>		
IV. CERTIFICATION		
Date of the Actual Completion of the International Search ²	Date of Mailing of this International Search Report ²	
25 OCTOBER 1983	09 NOV 1983	
International Searching Authority ¹	Signature of Authorized Officer ²⁰	
ISA/US	 PETER CHIN	

FURTHER INFORMATION CONTINUED FROM THE SECOND SHEET

V. OBSERVATIONS WHERE CERTAIN CLAIMS WERE FOUND UNSEARCHABLE ¹⁰

This international search report has not been established in respect of certain claims under Article 17(2) (a) for the following reasons:

1. Claim numbers, because they relate to subject matter ¹² not required to be searched by this Authority, namely:

2. Claim numbers, because they relate to parts of the international application that do not comply with the prescribed requirements to such an extent that no meaningful international search can be carried out ¹³, specifically:

VI. OBSERVATIONS WHERE UNITY OF INVENTION IS LACKING ¹¹

This International Searching Authority found multiple inventions in this international application as follows:

- I. Claims 1-46 directed to fibrous matrix containing microparticulate and neutral polymeric resin and method for making the same
- II. Claims 47-54 directed to a method of filtering lipids and pyrogenic substances.

1. As all required additional search fees were timely paid by the applicant, this international search report covers all searchable claims of the international application.

2. As only some of the required additional search fees were timely paid by the applicant, this international search report covers only those claims of the international application for which fees were paid, specifically claims:

3. No required additional search fees were timely paid by the applicant. Consequently, this international search report is restricted to the invention first mentioned in the claims; it is covered by claim numbers:

4. As all searchable claims could be searched without effort justifying an additional fee, the International Searching Authority did not invite payment of any additional fee.

Remark on Protest

- The additional search fees were accompanied by applicant's protest.
- No protest accompanied the payment of additional search fees.

III. DOCUMENTS CONSIDERED TO BE RELEVANT (CONTINUED FROM THE SECOND SHEET)		
Category *	Citation of Document, ¹⁶ with indication, where appropriate, of the relevant passages ¹⁷	Relevant to Claim No ¹⁸
Y	US,A, 3,839,314, PUBLISHED 01 OCTOBER 1974 FEKETE ET AL	47-54