



(11) **EP 2 109 094 A1**

(12) **EUROPEAN PATENT APPLICATION**

(43) Date of publication: **14.10.2009 Bulletin 2009/42** (51) Int Cl.: **G09G 3/36^(2006.01)**

(21) Application number: **08154287.0**

(22) Date of filing: **09.04.2008**

(84) Designated Contracting States:
AT BE BG CH CY CZ DE DK EE ES FI FR GB GR HR HU IE IS IT LI LT LU LV MC MT NL NO PL PT RO SE SI SK TR
Designated Extension States:
AL BA MK RS

(71) Applicant: **Barco NV**
8500 Kortrijk (BE)

(72) Inventor: **Debonnet, Jeroen**
8510 Marke (BE)

(74) Representative: **Bird, William Edward et al**
Bird Goën & Co.
Klein Dalenstraat 42A
3020 Winksele (BE)

(54) **LCD inversion control**

(57) A liquid crystal display device (40) has an inversion part (20) for controlling an inversion of a signal to be displayed, and a blanking insertion part (10) for driving the liquid crystal elements to a different level to that indicated by the signal in between fields or frames of the video signal, the inversion part being adaptable according to operation of the blanking insertion part.

By adapting the inversion to different modes of operation, the problem of the blanking interfering with the inversion in certain modes can be avoided. For example if for any given liquid crystal element, the blanking occurs more often when the signal is inverted and less often when the signal is not inverted, then, over time a net DC field can arise, causing that element to show a wrong color or become damaged.

1. Scanning backlight with BFI, interlaced driving, standard dot inversion@120Hz:

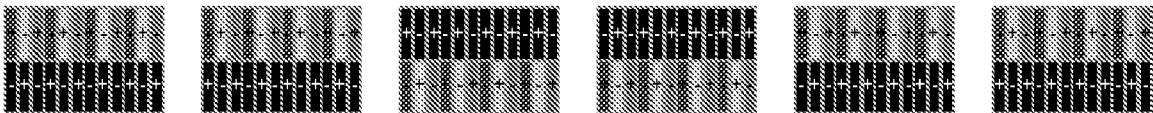

2. Full-on backlight, BFI using LCD, interlaced driving, standard dot inversion@120Hz:



3. Full-on backlight, BFI using LCD, progressive driving, standard dot inversion@120Hz:

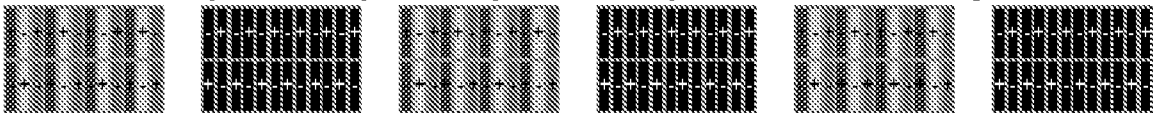

4. Full-on backlight, BFI using LCD, progressive driving, standard dot inversion @60Hz:

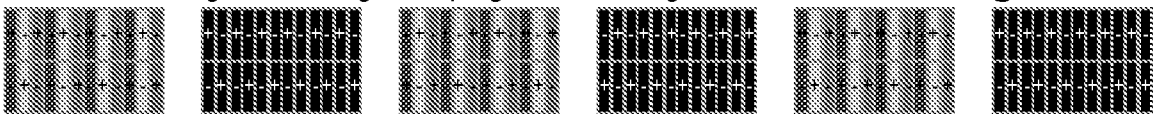

FIG. 3

EP 2 109 094 A1

Description**Technical field of the invention**

5 **[0001]** The present invention relates to liquid crystal devices and to corresponding systems and methods.

Background of the invention

10 **[0002]** It is known from US2008001890 that an LCD displays images by controlling light transmittance of a liquid crystal having dielectric anisotropy, using an electric field. Typically the LCD device has an LCD panel having pixel regions arranged in a matrix arrangement and a drive circuit for driving the LCD panel. The LCD panel has pixel electrodes and common electrodes formed to apply an electric field to each of the pixel regions. Periodic inversion of the field is needed to prevent polarization (and rapid permanent damage) of the liquid crystal material. Various schemes for periodic inversion are known, such as frame inversion, line-column inversion, and dot inversion. As described at: <http://www.techmind.org/lcd/> (section "Inversion"), inversion relies on the fact that in liquid crystal pixel cells, it is only the magnitude of the applied voltage which determines the light transmission (the transmission vs. voltage function is symmetrical about 0V). Unfortunately it is very difficult to get exactly the same voltage on the cell in both polarities, so the pixel-cell brightness will tend to flicker to some extent at half the frame-rate. If the polarity of the whole screen were inverted at once then the flicker could be highly objectionable. Instead, it is usual to have the polarity of nearby pixels in anti-phase, thus cancelling out the flicker over areas of any significant size.

15 **[0003]** In the frame inversion driving method, the polarity of the data signals supplied to the liquid crystal cells on the LCD display panel is inverted whenever a frame is changed. In the line-column inversion driving method, the polarity of the data signals supplied to the liquid crystal cells is inverted according to the line (column) on the LCD panel. In the dot inversion driving method, a data signal is supplied to each liquid crystal cell of the LCD panel, wherein the data signal has a polarity contrary to the data signal supplied to adjacent liquid crystal cells along vertical and horizontal directions. In addition, in the dot inversion driving method, the polarity of the data signals supplied to all the liquid crystal cells on the LCD panel is inverted for each frame. In addition, US2008001890 shows changing the inversion method of the LCD panel depending on the specific pattern of the image data so as to prevent unwanted colors being displayed due to variation of the common voltage.

20 **[0004]** It is also known to improve display of blurred edges of moving elements in a picture by inserting black frames or fields to reduce persistence. It is known from IDW/AD '05 pages 1257-1260 "What is needed in LCD panels for achieving CRT-like motion portrayal?" by A. A. S. Sluyterman to use black frame insertion together with a scanning backlight for improved motion portrayal.

Summary of the Invention

25 **[0005]** An object of the invention is to provide improved apparatus or methods.

[0006] According to a first aspect, the invention provides:

30 **[0007]** A liquid crystal display device, arranged to receive an incoming signal for display on a corresponding array of liquid crystal elements, the device having an inversion part for controlling an inversion of the signal, and a blanking insertion part for driving the liquid crystal elements to a different level to that indicated by the signal, the inversion part being adaptable according to operation of the blank insertion part.

35 **[0008]** By adapting the inversion to different modes of operation, the problem of the blank insertion interfering with the inversion in certain modes can be avoided. For example if for any given liquid crystal element, the insertion occurs more often when the signal is inverted and less often when the signal is not inverted, then, over time a net DC field may become non zero and that element can show a wrong color or become damaged, or flicker may become apparent.

[0009] Any additional features can be added, some are set out in dependent claims and described in more detail below.

40 **[0010]** The inversion part can be adaptable to balance a duration a given one of the liquid crystal elements is driven by an inverted signal with a corresponding duration for a non inverted signal, the durations excluding periods of black insertions for that given liquid crystal element.

[0011] This can be achieved in various ways, for example by predetermined inversion schemes to suit user selectable modes of display such as interlace or frame rate, or by variable durations actively controlled by measurements of net DC field or actual insertions, if needed.

45 **[0012]** The insertion part can be arranged to operate to insert any of black frames, black fields, black lines, or black dots, or groups of any of these.

[0013] The inversion part can be arranged to determine a current amount of net DC offset for each of the liquid crystal elements and to adapt the inversion to reduce the net DC offset.

50 **[0014]** The inversion part can be arranged to alter an inversion frequency.

[0015] The device can have an output to indicate a current phase of the inversion. This can be useful to enable synchronization with external parts for example.

[0016] The device can have a backlight arranged to provide scanned black insertion. This can add to the black insertion provided by the black insertion part.

[0017] The display device can be arranged to scan in an interlace mode or a progressive mode. The device can have a de-interlacer for receiving an interlaced video input signal and converting it to a non interlaced version.

[0018] The inversion part can have an external input to allow the inversion to be altered by an external control signal.

[0019] Other aspects of the invention include corresponding methods.

[0020] Another aspect provides a liquid crystal display device, arranged to receive an incoming signal for display on a corresponding array of liquid crystal elements, the device having a blanking insertion part for driving the liquid crystal elements to a different level to that indicated by the signal, and a response compensation part for compensating the signal for liquid crystal response time, to maintain intended light output.

[0021] Any of the additional features can be combined together and combined with any of the aspects. Other advantages will be apparent to those skilled in the art, especially over other prior art. Numerous variations and modifications can be made without departing from the claims of the present invention. Therefore, it should be clearly understood that the form of the present invention is illustrative only and is not intended to limit the scope of the present invention.

Brief Description of the Drawings

[0022] How the present invention may be put into effect will now be described by way of example with reference to the appended drawings, in which:

FIG. 1 shows a view of an LCD display device according to an embodiment,
 FIG. 2 shows timing diagrams of blank insertion and inversion according to an embodiment,
 FIG. 3 show views of pixels during a sequence of six frames for different modes of operation,
 FIG. 4 shows view of an LCD device according to another embodiment,
 FIG. 5 shows a side view of a backlight for use in embodiments,
 FIG. 6 shows a backlight and LCD array, and
 FIG. 7 to FIG. 9 show graphs representing operation of embodiments over time,

Description of illustrative Embodiments

[0023] The present invention will be described with respect to particular embodiments and with reference to certain drawings but the invention is not limited thereto but only by the claims. The drawings described are only schematic and are non-limiting. In the drawings, the size of some of the elements may be exaggerated and not drawn on scale for illustrative purposes. Where the term "comprising" is used in the present description and claims, it does not exclude other elements or steps. Where an indefinite or definite article is used when referring to a singular noun e.g. "a" or "an", "the", this includes a plural of that noun unless something else is specifically stated.

[0024] The term "comprising", used in the claims, should not be interpreted as being restricted to the means listed thereafter; it does not exclude other elements or steps. Thus, the scope of the expression "a device comprising means A and B" should not be limited to devices consisting only of components A and B. It means that with respect to the present invention, the only relevant components of the device are A and B.

[0025] Furthermore, the terms first, second, third and the like in the description and in the claims, are used for distinguishing between similar elements and not necessarily for describing a sequential or chronological order. It is to be understood that the terms so used are interchangeable under appropriate circumstances and that the embodiments of the invention described herein are capable of operation in other sequences than described or illustrated herein.

[0026] Moreover, the terms top, bottom, over, under and the like in the description and the claims are used for descriptive purposes and not necessarily for describing relative positions. It is to be understood that the terms so used are interchangeable under appropriate circumstances and that the embodiments of the invention described herein are capable of operation in other orientations than described or illustrated herein.

[0027] In some embodiments of the invention, a backlight is provided for a panel display. It may be desirable to measure colour output of the backlight, to enable it to be tuned for greater accuracy. A spectrometer can be provided in a path of the light output by the backlight, for example in a gap between the backlight and a liquid crystal array. Monochrome light sensors can also be provided for particular parts of the backlight. The backlight can also be arranged as a scanning backlight, for example having a number of sections in the form of trays. In a scanning mode these trays are blanked in a predetermined sequence. This type of blanking insertion can help to reduce image persistence between frames or between interlace fields and thus reduce visible motion artifacts. In this case, the backlight scanning should be synchronized with the scanning of the LCD drive circuitry for updating the display each frame or field.

[0028] Blanking in the form of black frame insertion (BFI) can be carried out by the LCD drive circuitry, for the same purpose, either instead of, or as well as the black insertion by the backlight. This can be scanned line by line rather than the tray by tray scanning of the backlight black insertion, and can therefore match the scanning of the image more closely. But it has now been appreciated that BFI using the LCD can interfere with the inversion described above.

[0029] The interference can result if the blank insertion occurs more often during one polarity of the inversion than the other polarity. Blanking can be defined as driving to black or to white or to any shade in between. Normally the inversion is fixed and so the BFI can be tailored to try to minimize such imbalance in the inversion. But for a display panel which should have a variety of scanning modes, or be able to handle inputs having different frame rates or different bit rates, it can be difficult to avoid such imbalance for all scanning modes.

[0030] Accordingly, embodiments of the invention provide a dynamic inversion scheme adapted to a scanning mode of the display. For example if successive lines have different inversions, this could be adapted to provide different inversions of pairs of lines, if this provides a more balanced inversion scheme. Alternatively an inversion scheme which changes each frame, could be changed every two frames if this provides a more balanced inversion for any given BFI scheme and scanning mode. The inversion can be adapted according to an input indicating a scanning mode, such as software selectable interlace or progressive scan modes. The BFI scheme may be software selectable and again the inversion mode can be adapted accordingly. An input can be provided to enable the inversion scheme to be controlled or adapted by an external signal. An output can be provided indicating a current inversion polarity. This could be used for adapting other parts, or for monitoring a degree of balance for example.

[0031] In some embodiments, an LCD display device has a compensation system that corrects the drive level of the LCD according to the LCD response times, ensuring correct perception of the calibrated colors in a BFI system. This can be combined with existing technology described in the existing Barco patent EP-B-0951007 on LFC - LCD Flicker Compensation.

[0032] Other embodiments can have a front sensor, built-in to observe the front of the display to characterize its properties, such as light output, gamma, response times for all transitions, and so on.

FIG. 1 and FIG. 2, embodiments of the invention

[0033] FIG. 1 shows an embodiment of an LCD device 40 in schematic form showing some of the principal features. A video input signal is fed to drive circuitry 50. This drive circuitry 50 has a blanking insertion part 10 and an adaptable inversion part 20. The adaptable inversion part 20 is arranged to control an inversion of the video signal, to avoid a cumulative build up of a net DC field on any individual one of the liquid crystal elements. The blanking insertion part is arranged to cause a blank display by a given one or more of the liquid crystal elements, in between successive fields or frames of the video signal. The inversion part is adaptable according to an operation of the blanking insertion part.

[0034] The drive circuitry 50 outputs a signal or signals to drive an array of liquid crystal display elements 30. There can be various ways of implementing these parts. For example there could be a frame buffer to which the video input is sent. The blanking level, for example a black level can be written into the frame buffer, to overwrite the video data after a given time. The output of the drive circuitry 50 could be generated by reading out the frame buffer according to established practice. The output could be inverted under the control of the adaptable inversion part 20. Alternatively the inversion could be carried out before the blanking insertion, for example by inverting selected values in the frame buffer, or by inverting parts of the video input before it is written to the frame buffer.

[0035] FIG. 2 shows graphically how the adaptation of the inversion can improve the balance of the inversion for a given pixel and its corresponding liquid crystal element. Time is represented by the x axis.

[0036] In this figure, a concrete example of blanking insertion is shown, in the form of black frame insertion, causing a problem with a standard LCD inversion scheme. A sequence of six frames at a frame rate of 120Hz is shown. Only the top left 4x2 pixels are shown, and are shown in shading if they are driven by the video input and in black if they are subject to black insertion. Their inversion polarity is shown by a + or a - symbol. In this example, the backlight is always on, the LCD uses progressive driving and standard dot inversion.

[0037] As every other frame is black, and the polarity also changes every other frame, in the case shown at the top of FIG. 2, it is apparent that for the top left pixel, the DC field is alternately positive or zero, since the inversion scheme means that every negative inversion field coincides with a blank insertion. This means a net positive field occurs over time for a given one of the LC cells. In LC applications, this is a problem. The net DC level over a LC cell must be zero. If not, free electrical charge carriers in the LC material will migrate towards the electrodes of the LC cell, and they will stick to that electrode. As a consequence, after some time, the electrical field will be seriously influenced by the amount of charge accumulated on the electrodes, resulting in image sticking, and other behaviour over time, as e.g. flicker.

[0038] A solution can be found in the lower part of FIG. 2: the inversion now only has half the frequency. This means that the electrical field is alternately positive and negative for a given pixel, which has the effect that the net average DC level of the electrical field in the LC cell will be zero.

Irregular inversion:

[0039] It is not essential that the blanking be regular, or that it drives to the DC field to zero. Alternative embodiments can have an irregular, non periodic inversion speed. The speed at which the polarity of a LC cell could be changed, can be slower; provided only that the net DC level over a period of time should remain zero. Dependent on the content applied to the LC cell, over a longer time, one could calculate the amount of positive and negative fields that have been applied to a certain LC cell, and electronically compensate for it.

[0040] A simple way to do this is shown in FIG. 2 above, using a predetermined, regular pattern. An alternative would be to provide a store for past inversion information and the accumulated field levels of every cell in a big frame store. Then a processor can be used to determine an optimal inversion scheme to continuously optimize the inversion of every separate pixel, with these two aims:

- 1) to make sure that the net current flowing in or out the full LC panel for every single frame, is as low as possible (some pixels will need to be charged, others will need to be discharged, the net effect can approach zero); and
- 2) to make sure that the net field on a single LC cell, over a short period, is also always 0.

[0041] This system can therefore use inversion schemes completely different from the known predetermined inversion schemes.

FIG. 3

[0042] FIG. 3 shows four examples of driving schemes. In each case, a sequence of six frames at a frame rate of 120Hz is shown. Only the top left 4x2 pixels are shown, and are shown in grey shading if they are driven by the video input and in black if they are subject to black insertion. Their inversion polarity is shown by a + or a - symbol.

[0043] A first line shows using a scanning backlight, and using interlaced driving, with a standard dot inversion. Only the lines in the current field are driven, the previous field is blanked with black lines. So, only half of the lines of the LCD are driven: the odd lines when the upper video field needs to be displayed, the even lines when the lower video field needs to be displayed. The inversion is balanced in this mode, as can be seen since for any given pixel, there are a similar number of positive and negative inversions in the sequence. Hence there is no net DC field.

[0044] The second, third and fourth sequences of FIG. 3 show using the backlight in continuous mode, and doing BFI using the LCD. In the second sequence, there is interlace driving and standard dot inversion. This shows unbalance in the inversions, as for any given pixel there are inversion symbols of only one polarity.

[0045] In the third sequence, there is progressive driving and standard dot inversion. This corresponds to the upper part of FIG. 2. As explained above, there is unbalance, as for any given pixel there are inversion symbols of only one polarity, leading to a net DC field across the LCD. In the fourth sequence, which corresponds to the lower part of FIG. 2, this is solved. As explained above, there is progressive driving again, but the dot inversion has been adapted to half the frame rate, that is 60 Hz. This means the inversion is balanced in this mode, as can be seen since for any given pixel, there are a similar number of positive and negative inversions in the sequence, and so no net DC field.

[0046] As can be seen, as soon as blanking out lines or frames on a LCD is carried out, this can have serious impact on the LCD if it results in a net DC field. In FIG. 3 sequence 2 and 3, every pixel ALWAYS gets the same polarity. This can cause damage to the LCD due to the above described effects.

[0047] Possible solutions to this problem for these modes are:

- change the inversion scheme from 120Hz to 60Hz
- do line-paired inversion for interlaced modes

[0048] As the LCD will have several "scanning modes", every scanning mode will have its optimal inversion scheme. By dynamically changing the inversion scheme to this optimum, the LCD can have improved or optimal performance and need not suffer from the Black Frame Insertion or interlaced driving concepts.

LCD response time compensation during BFI:

[0049] An LCD does not have an infinite response speed. Response times are in the range 6 - 8 ms. If the optical response of a LCD pixel is measured, it will have an upward curve and a downward decay curve. This delay in making a transition means that blanking insertion and other causes of transitions can cause the luminance to differ from that indicated by the video signal.

[0050] Rise and fall times are dependent on the drive level, and on the temperature of the LCD. For moving images: the image perceived by the user will be dependent on the amount of light that reaches the eye. This amount of light is

not dependent on the drive level, but merely on the area under the drive level versus time curve. This can be measured. As the rise and fall times are constantly changing with the temperature of the LCD, and the frame rate is changing with the input signal, this area under the curve is not fixed.

[0051] By constantly measuring and characterizing the response characteristics of the LCD, using sensors in the monitor, rise & fall times at the current frame rate and the current temperature can be measured. The sensor can be a front face sensor, built into a front of the LCD for example in an area near an edge of the LCD.

[0052] These measurements can be the input to a "LCD Response Lookup Table". This table is continuously updated with the characteristics of the LCD: which drive level is needed to have a correctly perceived light output. The video signal can be fed through this lookup table, and this way, the area under the response curve can be maintained in a 1-to-1 relation with the intended light output. Using a front sensor which continuously measures the response times of the LCD's transitions can be better than relying on predetermined values. As these change over time and temperature, it makes perfectly sense to continuously measure the response times for all transitions, and continuously change the compensation tables with the latest measured information.

FIG. 4

[0053] Regarding the standard video processing electronics for a high-resolution monitor, the digital video always passes through some FPGA or ASIC to do the necessary video processing (e.g. gamma lookup tables, scaling, OSD insertion, ...) before reaching the display device.

[0054] FIG. 4 shows another example of an LCD device. In this case, the video is input to a frame buffer 80, the blanking insertion part 10 writes the black level to appropriate parts of the frame buffer. The adaptable inversion part is coupled to an output of the frame buffer, and feeds an output signal with the inversions to drive the liquid crystal elements. A mode select input is fed to the drive circuitry 50 to choose the mode in the sense of interlace or otherwise, frame rate, line rate and so on, of the input, and of the output of the frame buffer.

[0055] Light sensors 90 are shown which can be used to feed back measured light levels to the drive circuitry to control a level compensation part which can adapt the levels at the input or output to the frame buffer for example, or be used to adapt the drive level of a backlight 70.

FIG. 5 to FIG. 9

[0056] FIG. 5 shows a side view of a display device having a backlight. A number of trays of the backlight are arranged horizontally in rows, each with its own monochrome light sensor. Each tray is formed of a horizontal PMMA light guide coupled to an LED source at one or both ends. A reflective foil is arranged at the back of the backlight. A diffuser is arranged at the front. A spectrometer is placed at the top to sense light in the gap between the diffusor and the trays. This example of a scanning backlight, with edge-lit topology can have LED light sources on left and right sides. It shows 6 light guides for scanning, though there can of course be other numbers of such guides. Each light guide can be illuminated with 2 LED PCB's: left and right. Every LED PCB can be driven with independent PWM. Optionally every color on the LED PCB also has independent PWM (4 controls: R, G, G, B). 6 monochrome light sensors are shown, one mounted on the back of every tray, in the middle. The spectrometer looks at the output of all trays together by looking in the cavity between the LED light guides and the diffuser.

[0057] FIG. 6 shows the backlight and the array of liquid crystal elements. In this view, the directions of scanning of the array and the backlight are shown.

An example of scanning modes is summarised in table 1:

Mode	Latency added by LCD driving mode	Motion blur reduction	Backlight dimming range
Scanning backlight with deinterlacer	Dependent on dimming range: @ 120Hz : 8 to 16 ms @ 100Hz : 10 to 20 ms (highest latency at lowest dimming)	good	10-100 cd/m ²
Scanning backlight with black line insertion for "CRT interlaced mode emulation"	Same	best	5 - 50 cd/m ²

(continued)

<i>Mode</i>	<i>Latency added by LCD driving mode</i>	<i>Motion blur reduction</i>	<i>Backlight dimming range</i>
Always-on backlight	= LCD response time: 8ms	No reduction	20-200 cd/m ²

[0058] FIG. 7 shows for an individual pixel in an LCD array a pixel response curve indicating a pixel transmission level over time. In a first addressing frame time, there is an upward curve labeled as the pixel response time, followed by a flat region for the rest of the frame time, marked as the illumination frame. This unshaded region can indicate a time when the backlight is illuminated. The next frame can be a black insertion time, in which case the pixel is driven to a black level during an addressing frame and remains there for the subsequent illumination frame.

[0059] In some embodiments, and some modes of operation, part or all of the rise or fall portion of the response may be in the illumination period. In this case, some compensation may be provided, so that the area under the response curve can be maintained in a 1-to-1 relation with the intended light output, as described above.

[0060] FIG. 8 shows a graph of frame delays relative to vertical position of a given pixel. It shows how with vertical position of the pixel, the illumination frame and addressing frames are delayed by different amounts in accordance with a scanning scheme.

[0061] FIG. 9 shows a similar view for delay relative to vertical position of different trays of a backlight. The lines show a response of an individual pixel at the top of the respective tray. The rectangles show times when the tray is lit. It shows how there is a corresponding relative delay between trays according to a vertical position of the tray.

Combinations with existing technologies:

[0062] In the following, some practical implementation issues of the embodiments are discussed, including combinations with existing technologies. The embodiments described can be used in combination with colour sequential driving technology commonly used in displays. In a colour sequential system a colour image is generated by sequentially generating multiple primary colour images that together form the colour image. For instance: in a colour sequential LCD display system, the backlight will switch continuously between for instance red, green and blue. In a first frame the backlight will be red, and during that frame the LCD pixels will be driven as to represent the red component in the colour image that is to be displayed. In the second frame the backlight will be set to green, and the LCD pixels will be driven as to represent the green component in the colour image that is to be displayed. In the third frame the backlight will be set to blue and the LCD pixels will be driven as to represent the blue component. If the frame rate is high enough then the human eye will integrate these images and the combination of these three individually monochrome frames will be perceived as a colour image. In the case of an LCD with LED backlight all red LEDs will be driven in frame one and no green or blue LEDs will be driven, in frame two only the green LEDs will be driven and in frame three only the blue LEDs will be driven. In the case of the LCD display with LED backlight, the colour point of the "primary colours" is extra modulated with a longer period. In other words: if one takes the example of a colour sequential LCD display that uses three frames Red, Green and Blue. Then the combination with backlight modulation to adjust colour will mean that the red colour itself is also modulated over time. A 2-frame two-level dither scheme for instance would mean that there are two (slightly) different variations on the red colour and that the luminance value of those two red colours can be different. The same concept is valid for the green and blue colours. In other words: the three frames from the colour sequential display system can also be compared to a single frame on a colour display, and that "colour display frame" can be modulated in colour and/or luminance over time in order to have a working implementation. In other words, a starting point can be a normal colour sequential system could have backlight values for sequential frames as follows: R, G, B, W, R, G, B, W, ... where R represents a red-alike colour with specific colour point and luminance and also G,B,W represent light with a specific colour point and luminance value. If for example a two-level dither scheme is used on this colour sequential display system then the backlight values for sequential frames could look like this: R1, G1, B1, W1, R2, G2, B2, W2, R1, G1, B1, W1, ... where R1 represents a red-alike colour with specific colour point and luminance and R2 represents a red-alike colour with colour point and/or luminance value that is different from R1. Also G1, G2; B1; B2; W1; W2 all represent pairs that have difference in colour point and/or luminance value (although it is not a requirement that all primaries are modulated, it is for example possible that R1 differs from R2, but that at the same time B1 is equal to B2).

[0063] Note that it is also possible to optimise the embodiments to include spatial variations over the display system area. For instance: with LCD displays there is always some variation in luminance behaviour (transfer curve) and colour behaviour (transmission spectrum) over the display area. This could mean for instance that certain areas on the LCD are more bright or dark than other areas or that there is a significant difference in luminance transfer curve depending on the exact place on the LCD. The same problem is also present for colour behaviour. It is possible to optimise the

two-level dither scheme by really taking into account the different luminance and/or colour behaviour of the display system over its complete display area. This could mean using other pixel data sent to the LC panel depending on the spatial location of the respective pixels being processed (this means that it is possible to combine backlight modulation with digital uniformity correction techniques where the pixel data of up to each individual pixel is changes in order to obtain a better uniformity in luminance and/or colour). Some display systems however have a fine pitch backlight system. Examples exist where the backlight of the LCD consists of several hundreds or thousands of small LEDs with a pitch of only a few millimetres. In that situation each individual LED only has effect on a relative small number of pixels located in the neighbourhood (above) of that LED. In such a situation it is also possible to also define specific frame luminance and/or colour values for the individual LEDs depending on their location and according also an individual pixel data scheme for all pixels (or a group of pixels) depending on the exact spatial location on the LCD display.

[0064] Selection of the exact dither variables (number of frames, backlight intensities for all frames, colour point of the backlight for all frames, display pixel dither scheme for all frames and for all video levels) is based on a number of parameters. A first parameter is the behaviour of the backlight: the luminance and colour behaviour of the backlight in function of the driving level of the backlight (typically a backlight can be driven between a minimum DAC-value zero and a maximum DAC-value for instance 4095. The DAC-value is related to the current sent to the backlight lamps or LEDs). A second parameter is the behaviour of the display panel (LCD, DMD, DLP, ...) This can be regarded as the luminance and colour behaviour of the panel as a function of the DDL of the panel. In other words: how does the panel behave in luminance and colour behaviour in function of the pixel data. For a transmissive LCD for instance this can be expressed as a transmission spectrum in function of digital driving values of the LCD. The table of digital driving values can consist of a one-dimensional array in case of a monochrome LCD, a multidimensional table in case of a monochrome LCD with each pixel consisting of multiple sub pixels or a multidimensional table in case of a colour LCD with each pixel consisting of a number of coloured sub pixels. This means that the optimal dither variables are depending on parameters that can be different for each display system. Indeed: the backlight behaviour can differ for each individual backlight (for instance a LED backlight where there is typically a lot of variance between luminance and colour behaviour between different batches of LEDs) or for each individual panel (for instance: the transmission spectrum of an LCD panel can differ significantly from panel to panel).

[0065] Therefore there are two possibilities: if the variations in parameters do not differ a lot between individual devices then the same dither variables can be used for all devices of a same type or a same batch of devices. This significantly reduces the time to characterize the display systems and to determine the exact dither scheme that will be used. If at the other hand a very exact reproduction of luminance and/or colour is desired then each individual display system can be characterized to determine an optimal dither scheme for each display system. Another approach can be to select the exact dither scheme such that even when variation between the display systems is present the performance will still be more or less the same. For example: suppose that the backlight is based on LEDs. LEDs that are dimmed to deep will not emit any light anymore. The exact dimming range can differ between different batches of LEDs or even from LED to LED. Therefore a compromise would be not to use very deep dimming (so not optimal) but choose a value that will be safe for all display systems.

[0066] Embodiments can use a combination of backlight luminance and colour coordinates and panel behaviour to obtain an accurate reproduction of colour and luminance. If of course the behaviour of the backlight (luminance source of the display system) and/or the panel (modulation system of the display system) changes then the dither scheme might not be optimal anymore. Therefore it is possible that extra measurement devices are used to compensate for these behaviour changes. A first example is that a sensor can monitor the luminance and colour behaviour of the backlight system. If the luminance and/or colour behaviour changes then a new dither scheme can be calculated based on the known original colour and luminance behaviour and the new measured colour and luminance behaviour of the backlight system. Suppose that after a few thousand hours of operation the backlight has a colour shift towards red, then this information can be used to make sure that the desired colour point of the backlight for the individual frames of the dither scheme is still correct.

[0067] The same thing is of course valid for luminance: suppose that the transfer curve luminance versus driving level of the backlight system changes, then it might be necessary to use other DAC-values to drive the backlight system. This can be a continuous process: measuring the backlight output and calculating the new dither scheme. Note that a threshold can be built in: as long as the performance due to changes in backlight behaviour do not exceed a certain threshold then the current dither scheme is used. If the threshold is exceeded then a new dither scheme can be calculated. Note that the sensor measurements can be done continuously or at fixed or at selected points in time. Note that it is not always necessary to measure all individual frames of the dither scheme: if only one frame is measured in luminance and colour then very often the measurements for the other frames can be predicted with this information. Also note that it is possible to also measure the transmission spectrum of the LCD (ideally in function of driving level, although there are situations possible where all driving levels suffer from a same change in transmission spectrum) during lifetime of the display. This information then can also be used to make sure that the two-level dither scheme is configured optimally. These measurements of the transmission spectrum of the display system can take place on request of the user, at regular times or

continuously.

[0068] Combination with stabilization devices is also possible. A stabilization device typically measures parameters such as but not limited to luminance and/or colour point or contrast ratio in a specific situation and makes sure that for example (but not limited to) luminance and/or colour is always equal to a selected target value (by changing the backlight driving values or the pixel values). For instance: in medical imaging the white luminance (luminance output when fully white is displayed) of the display is very often kept stable at a selected level (for instance 500 cd/m²). It is of course possible to use such a stabilization system together with other features described above. In this situation the white luminance (and perhaps also the white colour point) will determine luminance output and the colour point of the display. The two level dither scheme then can be configured so that both the luminance and colour point at full white do not change anymore. This can be done by making sure that the average luminance output over the dither period is equal to the target luminance and also that the average colour point over the dither period is equal to the target colour point.

[0069] The calculation method of the dither variables (backlight luminance and colour values and pixel dither data) can give more accurate results in many situations if measurements are of the final output of the combination of backlight system and panel.

[0070] This is because the backlight system produces light with a certain spectrum that is usually well spread over the visual spectrum range (380nm -800 nm). At the same time: also the transmission spectrum of the panel is spread over the same visual spectrum range. For example: suppose a monochrome display system with a backlight is used and the colour shift measured when going from video level zero to video level maximum. It is then not a priori certain that proportionally the same colour shift will be seen if there are changes to the colour of the backlight. In other words: suppose that the x-coordinate of the measured light of the display system is 20% higher at maximum video level compared to minimum video level then it is not a priori certain that if the backlight colour is changed, that this will still be valid. Therefore it is in theory necessary to measure a lot of combinations of backlight luminance/colour point and panel or at least to verify the performance of the dither scheme. The fundamental reason is that the light sources in the backlight system (typically white light or red, green and blue sources) do not follow the spectrum curve of the x-coordinate and the y-coordinate.

[0071] There is a possibility to avoid these many measurements by calculating mathematically based on measurements of the transmission spectrum of the backlight (possibly for multiple luminance values) and a characterization of the transmission spectrum (filter characteristic) of the panel. In other words every combination of backlight luminance/colour point with panel can then be predicted. In other words: it is then possible to predict the luminance and colour behaviour of the complete display system based on the settings of the individual components. Also if a backlight system with sources that have a very narrow spectrum (such as certain LEDs) is used, then it could also be acceptable to assume that the panel will result in the same colour shift (proportionally) and this independent of the colour point of the backlight system. Note that due to metamerism it is possible that multiple solutions are found that seem to perform equally well in luminance and/or colour reproduction accuracy. However, one such a solution might have other favourable properties such as being less sensitive to flicker and easier to manufacture (because the required colour points or dimming ratios are more feasible).

[0072] When using LCDs with long response time it might be useful to put extra constraints on the dither scheme for the pixel data. Indeed: with the embodiments described, it is common that in consecutive frames the pixel data must change from very low to very high values. If the response time of the LCD is very long then it is possible that visual artefacts are introduced in this way: the luminance and/or colour values for that pixel can be completely wrong. One possible solution is to avoid using transitions that the LCD is not capable of. It is easy to measure a transition chart that shows the rise and fall times of the LCD when going from one video level to another video level. If the rise or fall time for a particular transition (for instance video level 23 - video level 214) is too large, then this transition can be avoided in the dither scheme and another (less optimal related to reproduction of colour point and/or luminance) dither scheme can be used for that particular case (this could also include using other luminance and/or colour point values for the backlight).

[0073] Another solution is to use a blinking backlight system. Indeed: it does not really matter where exactly the light transmission takes place in the frame. This can be equally distributed over the frame or concentrated in one or more parts of a frame period. If one uses a blinking backlight for instance, that concentrates most of the light energy at the end of each frame then the problem of slow LCDs can be reduced. This means of course that the backlight will need to be able to emit the energy in a more concentrated form (an equal amount of energy in a smaller part of time). If the energy is concentrated (for instance but not limited to) at the end of the frame, then the LCD has more time to complete the required transitions before the actual light is produced. This means that the problem is solved for all transitions of pixels (that would normally result in artefacts and/or wrong luminance and or colour point) and that take place before the backlight produces light.

[0074] Also note that it is possible to combine embodiments of the present invention and various response time improvements techniques that use changes in the pixel data such as but not limited to overdrive techniques, feed forward and feed backward compensation.

[0075] Another method to cope with the response time of the panel is to actually take into account the response time of the panel when calculating the required dither scheme. If it is known in advance that a particular pixel transition requires a particular amount of time then it can be calculated what the light will be that is produced by the display system during that transition. Of course this requires that at all times the exact transition times are known. Note that the response time of LCD can change over time and with temperature.

[0076] There are also other possible reasons to not use certain transitions between grey levels in the pixel dither scheme or to not use at all specific grey levels in the pixel dither scheme. It could be useful to avoid specific video levels that have bad uniformity (luminance and/or colour) over the display area or that have bad viewing angle characteristics. The two-level dither has indeed the ability to avoid specific driving signals sent to the LCD by changing the backlight luminance and/or colour point for some or all frames of the dither period. For example: on a greyscale LCD, instead of using video level 8 (rather dark level) with bad viewing angle behaviour, it could be interesting to use level 200 (rather high video level) with better viewing angle behaviour and make sure that the luminance output is still correct by changing the luminance value of the backlight for one or more frames. In this case it would be required to decrease the luminance value of the backlight for at least one frame in order to make sure that the average luminance level is still correct.

[0077] A two-level dither scheme could introduce flicker on the display system. This is because the luminance intensity of the backlight is modulated from frame to frame and rather large differences between frames are possible. An easy solution to avoid flicker is increasing the frame rate of the display system, but unfortunately this is not always possible. Another solution is to keep the luminance value of the frame more or less constant by inserting a phase difference between the modulations of the different colour components. For instance: in a colour LCD system with a three-frame two-level dither scheme, with luminance intensities of the backlight being L1 for frame 1, L2 for frame 2 and L3 for frame 3, one could in frame one drive the red colour component to luminance value L1, the green to value L2 and the blue to value L3. In frame two then one could drive red to L2, green to L3 and blue to L1. In the third frame one could drive red to L3, green to L1 and blue to L2. Suppose that L1 corresponds to 1.5 times the average luminance value of the backlight, and L2 corresponds to 1 time the average luminance value of the backlight and L3 corresponds to 0.5 times the average luminance value of the backlight. Then the actual perceived luminance for frame one will be $L1+L2+L3= 1.5+1+0.5= 3$ and this is also the luminance of frames 2 and 3. So there is no luminance flicker present anymore. Of course the luminance intensity of the three colours is normally not the same (green could have higher intensity than red and blue) but the general idea has been described here: by inserting a phase difference or scrambling the modulation scheme for the three colours in a well-chosen way, it is possible to reduce luminance flicker. The same argument is valid for colour flicker: by inserting a phase difference or scrambling the modulation scheme of the three colours in a well-chosen way, it is possible to reduce the colour-point difference (average of the three main colours) between the three frames and therefore reduce colour flicker.

[0078] Another solution to avoid flicker is to also introduce a spatial shift in the modulation scheme. For instance: if there is a LED backlight or CCFL backlight with multiple elements that emit light, then it is possible to drive in frame one some part of the display area with (local) backlight luminance value L1, and drive other parts of the backlight with respective luminance values L2 and L3. For example: a backlight with LEDs organized in stripes and a two-frame two-level dither scheme: one could drive in frame one the upper part of the display with local backlight value L1 and the lower part of display with local backlight value L2 and in the second frame one would then drive the upper part of the display with local backlight value L2 and the lower part of the display with local backlight value L1. This will cause the average luminance over the complete display area to be constant over all frames.

[0079] Another possible problem with embodiments of the present invention could be the existence of motion artefacts due to the multi-frame dither block. Indeed: if moving objects are shown on the display system then it is possible that flicker and motion artefacts are created because the actual image to be displayed changes in the middle of a "period" of the dither algorithm (temporal moiré artefacts between backlight and

[0080] LCD pixel data). Suppose a three-frame two-level dither scheme is used and a moving line is to be shown on the display. In that case the luminance value of the line will be dependent on the position because of the movement. Of course this is an artefact that is easy to see. There are a few solutions for this problem: a first simple solution is to avoid any movement (changes of image to be displayed) during the frame period of the dither scheme. In other words: suppose that a three-frame two-level dither scheme is used, then the image to be displayed on the display should only change once in three frames.

[0081] In that way there will be no motion artefacts present because the image is stable during the period of the dither scheme. Note that this can be achieved by lowering the actual frame rate going to the display system or by internally increasing the frame rate going to the panel itself (a compromise between these two is also possible). For example: it would be not a problem to have an external frame rate of 50 Hz to the display system and an internal frame rate towards the LC panel of 150 Hz (in case of a three-frame two-level dither scheme). A second solution to avoid motion artefacts is more complex. One could take into account the movement of the object and therefore really adapt the pixel data sent to the display to make sure that the average luminance value (over the period of the dither scheme) and/or colour point of each pixel is as much as possible (at least remove peaks) correct for each location on the display. Of course this is

a more complex calculation, but it allows the actual frame rate to be kept high.

[0082] A remarkable application of the two-level dither scheme is to improve spatial colour-uniformity on greyscale and/or colour display systems. Suppose there is a greyscale LCD system and there is spatial colour non-uniformity over the display area. For example take a grey scale display for which the upper part of the display has a higher x-coordinate (colour coordinate) than the lower part of the display. Then it is possible to correct for this spatial colour non-uniformity by: creating a two-level dither scheme with two frames, where the first frame has a backlight colour point that is somewhat lower in x-coordinate compared to the original colour point of the display system without two-level dither, and the second frame has a backlight colour point that is somewhat higher in x-coordinate compared to the original colour point of the display system without two-level dither. If the pixels in the lower part (that has "correct" x-coordinate) are driven equally in frame one and frame two then the colour point of those pixels will still be correct. The pixels in the upper part of the display however (where the x-coordinate is somewhat too high) are driven with a higher pixel value in the first frame and a lower pixel value in the second frame, which will correct for the spatial colour non-uniformity in the greyscale display system. Note that this is example is not intended to be limiting; it is just given for clarity. The principle is that by providing frames where the backlight colour and/or luminance is modulated and at the same time the pixel data is modulated, it is possible to improve colour non-uniformity on greyscale display systems. Note that the same principle can be applied to reduce colour non-uniformity on colour display systems. In that case there are even more degrees of freedom so it is easier to find an optimal solution. Note that there are of course border conditions because the luminance value needs to be correct also. But this is a simple mathematical problem that can be solved even by just checking all possible combinations of backlight luminance and colour point values for the individual frames and combining this with pixel data to be send to the display and information on colour non-uniformities on the display area.

Claims

1. A liquid crystal display device (40), arranged to receive an incoming signal for display on a corresponding array of liquid crystal elements, the device having an inversion part (20) for controlling an inversion of the signal, and a blanking insertion part (10) for driving the liquid crystal elements to a different level to that indicated by the signal, the inversion part being adaptable according to operation of the blanking insertion part.
2. The device of claim 1, the inversion part being adaptable to balance a duration a given one of the liquid crystal elements is driven by an inverted signal with a corresponding duration for a non inverted signal, the durations excluding periods of blanking insertions for that given liquid crystal element.
3. The device of claim 1 or 2 the adaptation of the inversion involving selection from predetermined inversion schemes.
4. The device of any preceding claim, the blanking insertion part being arranged to operate to insert any of black frames, black fields, black lines, or black dots, or groups of any of these.
5. The device of any preceding claim, the inversion part being arranged to determine a current amount of net DC offset for each of the liquid crystal elements and to adapt the inversion to reduce the net DC offset.
6. The device of any preceding claim, the adaptable inversion part being arranged to alter an inversion frequency.
7. The device of any preceding claim, the inversion part having an external input to allow the inversion to be altered by an external control signal.
8. The device of any preceding claim having an output to indicate a current phase of the inversion.
9. The device of any preceding claim and having a backlight arranged to provide scanned black insertion.
10. The device of any preceding claim having a frame buffer arranged to output an interlaced or a non interlaced version of the input signal.
11. A method of using a liquid crystal display device to receive an incoming signal for display on a corresponding array of liquid crystal elements, the method having the steps of controlling an inversion of the signal, causing blank insertion by driving the liquid crystal elements to a different level to that indicated by the signal and adapting the inversion according to operation of the blank insertion.

EP 2 109 094 A1

12. A liquid crystal display device, arranged to receive an incoming signal for display on a corresponding array of liquid crystal elements, the device having a blanking insertion part for driving the liquid crystal elements to a different level to that indicated by the signal, and a response compensation part for compensating the signal for liquid crystal response time, to maintain intended light output.

5

10

15

20

25

30

35

40

45

50

55

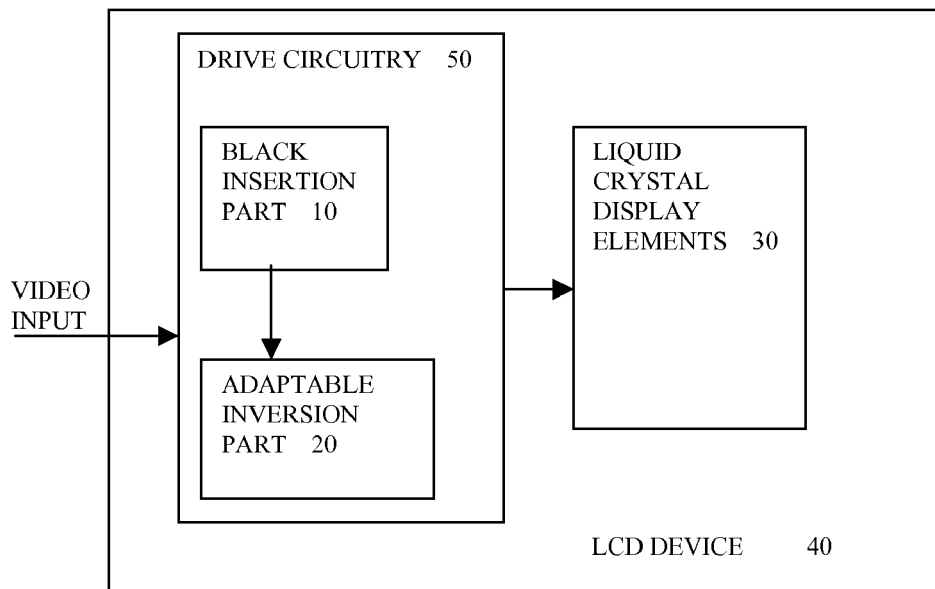

FIG. 1

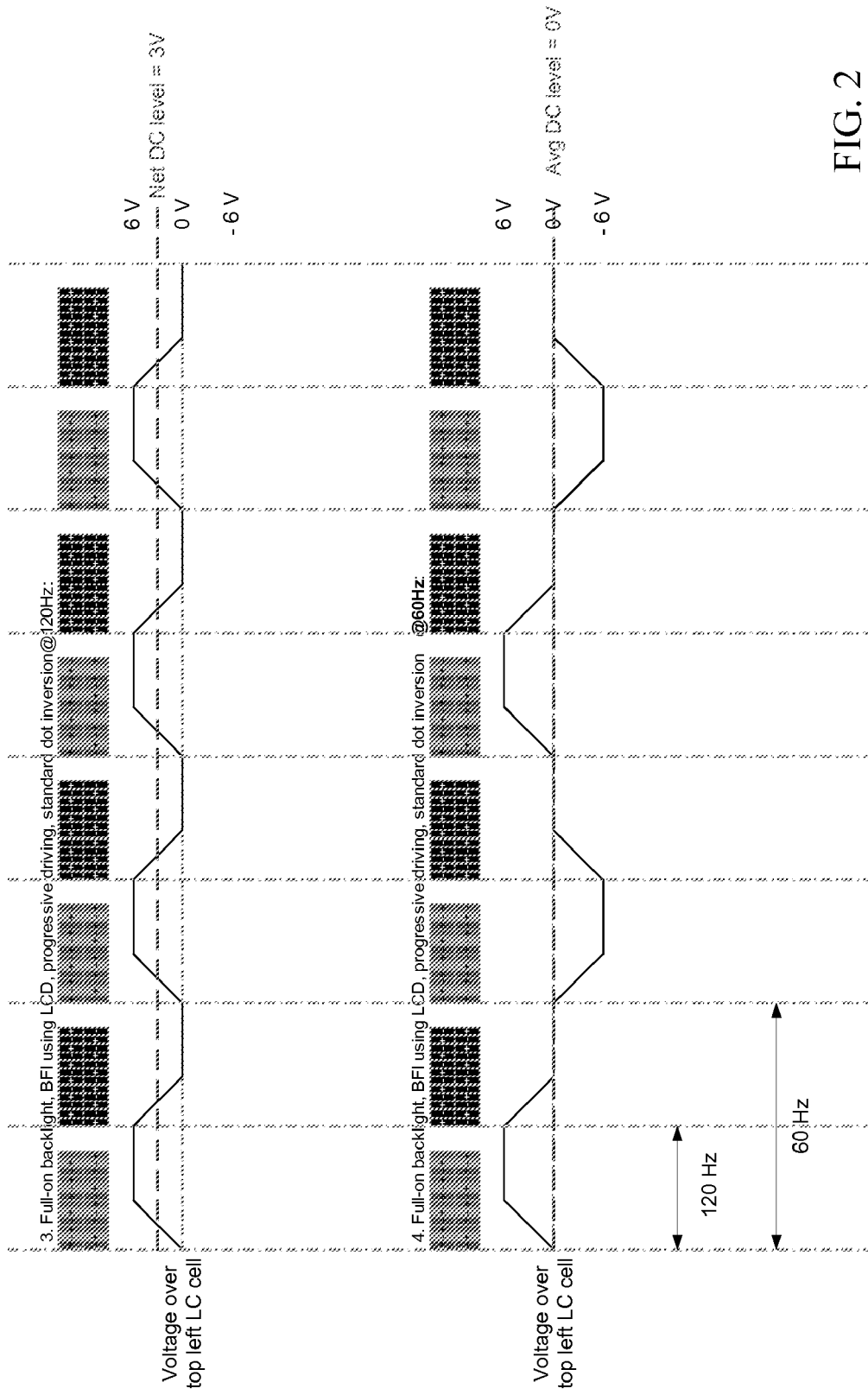
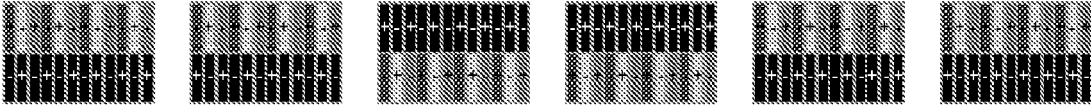

FIG. 2

1. Scanning backlight with BFI, interlaced driving, standard dot inversion@120Hz:



2. Full-on backlight, BFI using LCD, interlaced driving, standard dot inversion@120Hz:



3. Full-on backlight, BFI using LCD, progressive driving, standard dot inversion@120Hz:

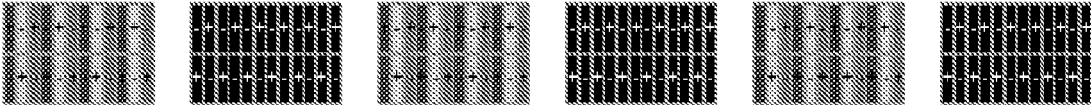

4. Full-on backlight, BFI using LCD, progressive driving, standard dot inversion @60Hz:

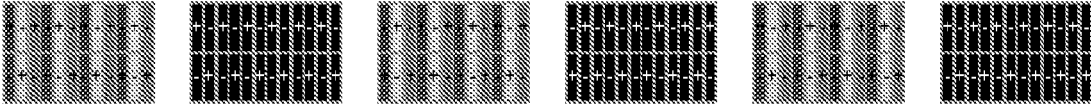

FIG. 3

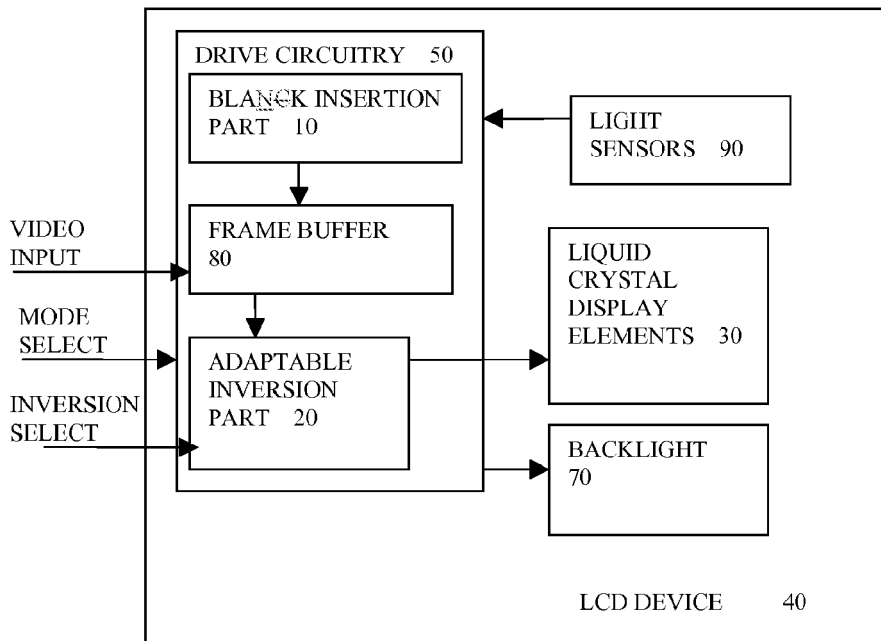

FIG. 4

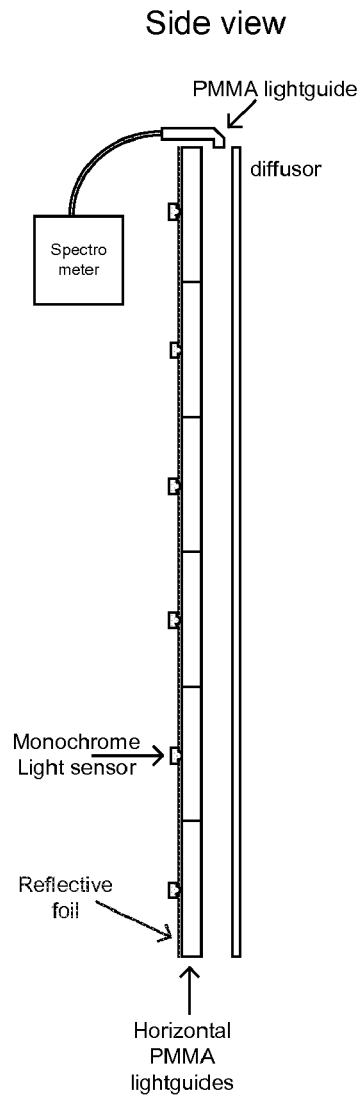

FIG. 5

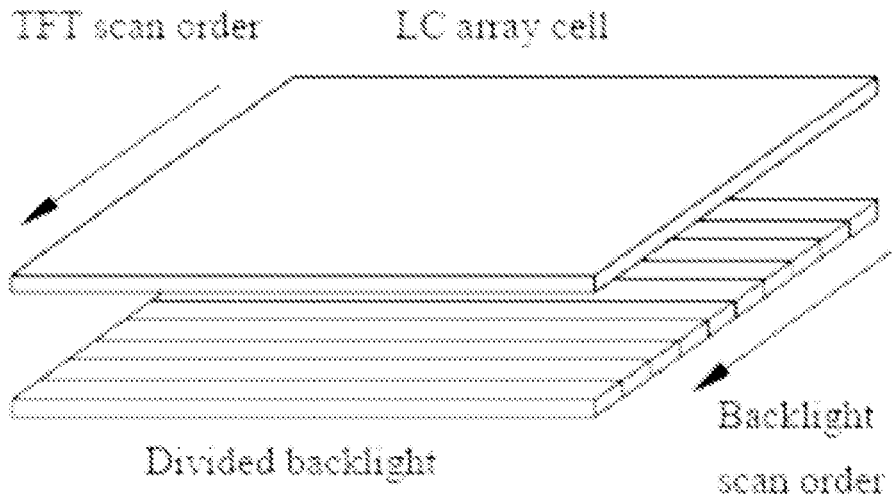

FIG. 6

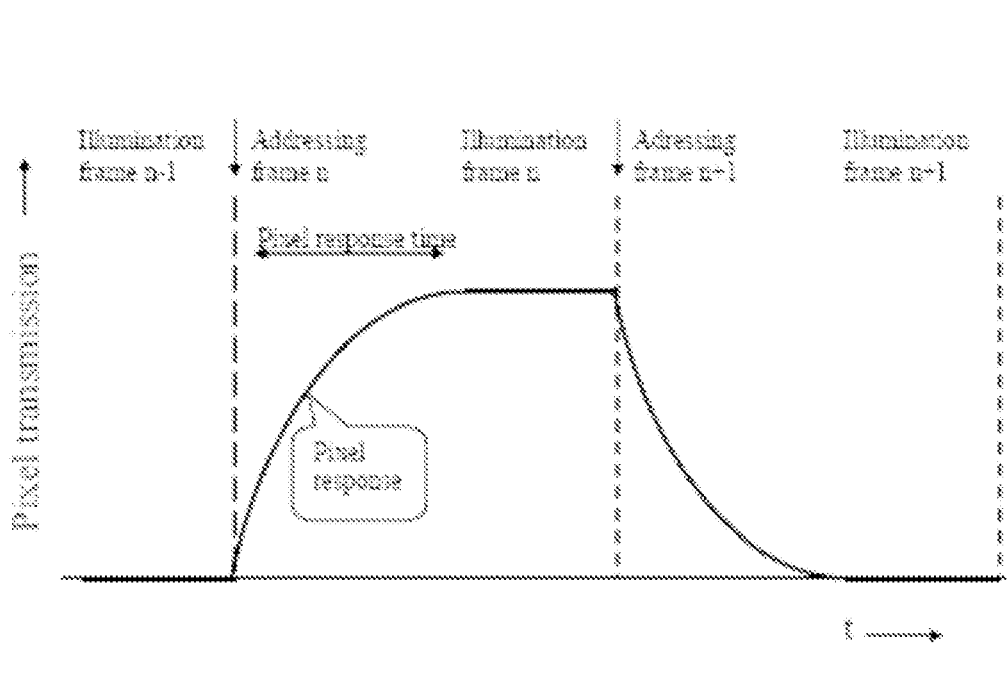

FIG. 7

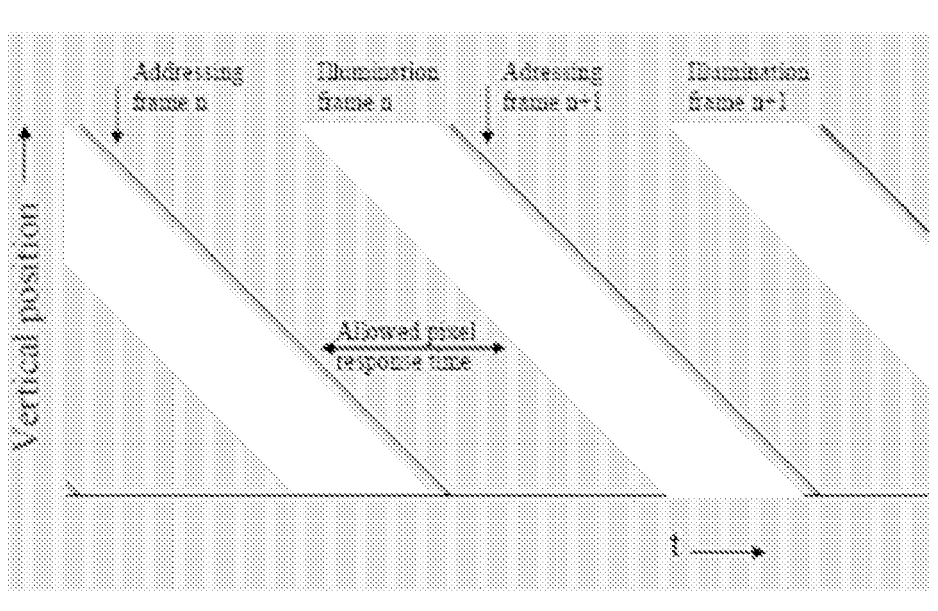

FIG. 8

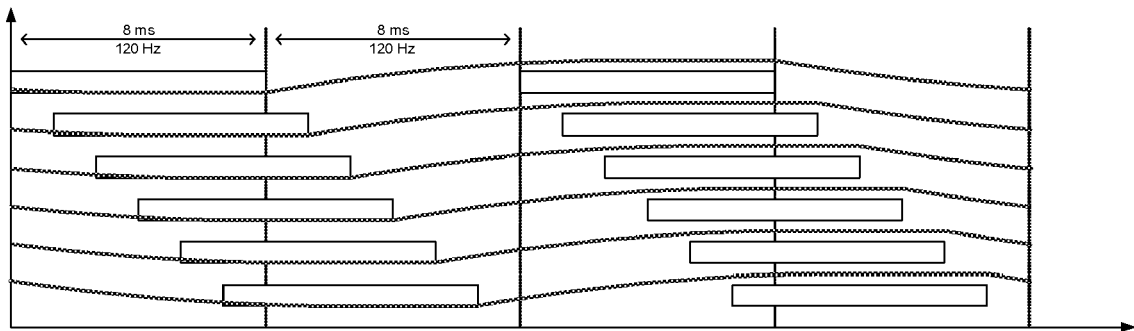

FIG. 9



EUROPEAN SEARCH REPORT

Application Number
EP 08 15 4287

DOCUMENTS CONSIDERED TO BE RELEVANT			
Category	Citation of document with indication, where appropriate, of relevant passages	Relevant to claim	CLASSIFICATION OF THE APPLICATION (IPC)
X	US 2003/058229 A1 (KAWABE KAZUYOSHI [JP] ET AL) 27 March 2003 (2003-03-27) * paragraphs [0101], [0105], [0107], [0110], [0116]; figures 1,4 * * paragraphs [0142], [0167] - [0169]; figures 50-52 *	1-11	INV. G09G3/36
X	WO 92/21123 A (HOTTO ROBERT [US]) 26 November 1992 (1992-11-26) * page 2, line 12 - page 4, line 7 * * page 14, lines 1-29 * * page 26, lines 1-23; figure 1 * * page 29, lines 11-23; figure 1 * * page 37, lines 12-33; figure 7 * * page 38, line 10 - page 39, line 4 *	1,2,4,5,7-11	
X	US 2004/239602 A1 (KIM JONG DAE [KR] ET AL) 2 December 2004 (2004-12-02) * paragraph [0089] *	1,3,4,11	
A	US 6 469 684 B1 (COLE JAMES R [US]) 22 October 2002 (2002-10-22) * the whole document *	1-11	TECHNICAL FIELDS SEARCHED (IPC) G09G
A	WO 00/25175 A (PIRS JANEZ [SI]; MARIN BOJAN [SI]; PIRS SIVIJA [SI]; PONIKVAR DUSAN [S]) 4 May 2000 (2000-05-04) * page 7, line 3 - page 8, line 26 *	2	
A	US 2001/004253 A1 (FUKUTOKU SYOUICHI [JP] ET AL) 21 June 2001 (2001-06-21) * paragraphs [0062], [0065], [0072], [0073] *	1-11	
----- -/--			
4 The present search report has been drawn up for all claims			
Place of search The Hague		Date of completion of the search 14 January 2009	Examiner van Wesenbeek, R
CATEGORY OF CITED DOCUMENTS X : particularly relevant if taken alone Y : particularly relevant if combined with another document of the same category A : technological background O : non-written disclosure P : intermediate document		T : theory or principle underlying the invention E : earlier patent document, but published on, or after the filing date D : document cited in the application L : document cited for other reasons & : member of the same patent family, corresponding document	

EPO FORM 1503 03.82 (P04C01)



EUROPEAN SEARCH REPORT

Application Number
EP 08 15 4287

DOCUMENTS CONSIDERED TO BE RELEVANT			
Category	Citation of document with indication, where appropriate, of relevant passages	Relevant to claim	CLASSIFICATION OF THE APPLICATION (IPC)
X	WO 2006/095304 A (KONINKL PHILIPS ELECTRONICS NV [NL]; BOIKO EUGENE [GB]; HUGHES JOHN R) 14 September 2006 (2006-09-14) * page 1, lines 21-29 * * page 11, line 3 - page 13, line 17 * -----	12	
X	WO 2006/114732 A (KONINKL PHILIPS ELECTRONICS NV [NL]; HECTOR JASON R [GB]; HUGHES JOHN) 2 November 2006 (2006-11-02) * page 6, line 28 - page 11, line 22; figures 3-5 * * page 14, lines 10-16; figure 9 * -----	12	
X	US 2007/146394 A1 (AHN JI Y [KR]) 28 June 2007 (2007-06-28) * paragraph [0042]; figure 14 * -----	12	
			TECHNICAL FIELDS SEARCHED (IPC)
The present search report has been drawn up for all claims			
4	Place of search The Hague	Date of completion of the search 14 January 2009	Examiner van Wesenbeeck, R
CATEGORY OF CITED DOCUMENTS X : particularly relevant if taken alone Y : particularly relevant if combined with another document of the same category A : technological background O : non-written disclosure P : intermediate document		T : theory or principle underlying the invention E : earlier patent document, but published on, or after the filing date D : document cited in the application L : document cited for other reasons & : member of the same patent family, corresponding document	

EPO FORM 1503 03.82 (F04C01)



Application Number

EP 08 15 4287

CLAIMS INCURRING FEES

The present European patent application comprised at the time of filing claims for which payment was due.

- Only part of the claims have been paid within the prescribed time limit. The present European search report has been drawn up for those claims for which no payment was due and for those claims for which claims fees have been paid, namely claim(s):
- No claims fees have been paid within the prescribed time limit. The present European search report has been drawn up for those claims for which no payment was due.

LACK OF UNITY OF INVENTION

The Search Division considers that the present European patent application does not comply with the requirements of unity of invention and relates to several inventions or groups of inventions, namely:

see sheet B

- All further search fees have been paid within the fixed time limit. The present European search report has been drawn up for all claims.
- As all searchable claims could be searched without effort justifying an additional fee, the Search Division did not invite payment of any additional fee.
- Only part of the further search fees have been paid within the fixed time limit. The present European search report has been drawn up for those parts of the European patent application which relate to the inventions in respect of which search fees have been paid, namely claims:
- None of the further search fees have been paid within the fixed time limit. The present European search report has been drawn up for those parts of the European patent application which relate to the invention first mentioned in the claims, namely claims:
- The present supplementary European search report has been drawn up for those parts of the European patent application which relate to the invention first mentioned in the claims (Rule 164 (1) EPC).



**LACK OF UNITY OF INVENTION
SHEET B**

Application Number
EP 08 15 4287

The Search Division considers that the present European patent application does not comply with the requirements of unity of invention and relates to several inventions or groups of inventions, namely:

1. claims: 1-11

adapting the polarity inversion driving of the liquid crystal elements according to the operation of the black insertion

2. claim: 12

liquid crystal display device with response compensation part for compensating the signal for liquid crystal response time

ANNEX TO THE EUROPEAN SEARCH REPORT
ON EUROPEAN PATENT APPLICATION NO.

EP 08 15 4287

This annex lists the patent family members relating to the patent documents cited in the above-mentioned European search report. The members are as contained in the European Patent Office EDP file on
The European Patent Office is in no way liable for these particulars which are merely given for the purpose of information.

14-01-2009

Patent document cited in search report	Publication date	Patent family member(s)	Publication date
US 2003058229 A1	27-03-2003	CN 1410956 A	16-04-2003
		KR 20030011613 A	11-02-2003
		TW 559771 B	01-11-2003
		US 2007085794 A1	19-04-2007

WO 9221123 A	26-11-1992	AU 2010692 A	30-12-1992
		CA 2109951 A1	26-11-1992
		EP 0586544 A1	16-03-1994
		JP 6508447 T	22-09-1994
		US 5444457 A	22-08-1995
		US 5280280 A	18-01-1994

US 2004239602 A1	02-12-2004	KR 20040009136 A	31-01-2004
		US 2007030236 A1	08-02-2007

US 6469684 B1	22-10-2002	NONE	

WO 0025175 A	04-05-2000	AT 267410 T	15-06-2004
		AU 6494599 A	15-05-2000
		DE 69917479 D1	24-06-2004
		DE 69917479 T2	02-06-2005
		EP 1131669 A2	12-09-2001
		US 7061462 B1	13-06-2006

US 2001004253 A1	21-06-2001	JP 2001174783 A	29-06-2001
		KR 20010062355 A	07-07-2001
		TW 486683 B	11-05-2002

WO 2006095304 A	14-09-2006	CN 101138018 A	05-03-2008
		JP 2008533519 T	21-08-2008

WO 2006114732 A	02-11-2006	NONE	

US 2007146394 A1	28-06-2007	CN 1991962 A	04-07-2007
		JP 2007178989 A	12-07-2007
		KR 20070068767 A	02-07-2007

REFERENCES CITED IN THE DESCRIPTION

This list of references cited by the applicant is for the reader's convenience only. It does not form part of the European patent document. Even though great care has been taken in compiling the references, errors or omissions cannot be excluded and the EPO disclaims all liability in this regard.

Patent documents cited in the description

- US 2008001890 A [0002] [0003]
- EP 0951007 B [0031]