

(19) World Intellectual Property Organization
International Bureau



(43) International Publication Date
2 February 2006 (02.02.2006)

PCT

(10) International Publication Number
WO 2006/010992 A1

- (51) International Patent Classification⁷: **B66B 7/04**
- (21) International Application Number:
PCT/IB2004/002416
- (22) International Filing Date: 19 July 2004 (19.07.2004)
- (25) Filing Language: English
- (26) Publication Language: English
- (71) Applicant (for all designated States except US): **OTISEL-EVATOR COMPANY** [US/US]; Ten Farm Springs Road, Farmington, CT 06032 (US).
- (72) Inventors; and
- (75) Inventors/Applicants (for US only): **CLOUX, Jean-Noël** [FR/FR]; 14, rue Pasteur, F-45290 Nogent sur Vernisson (FR). **COQUERELLE, Thomas** [FR/FR]; 445, rue Lefebvre d'Orval, F-59500 Douai (FR). **REBILLARD, Pascal** [FR/FR]; 76, rue de Montbricon, F-45500 Gien (FR). **BEAUCHAUD, Frédéric** [FR/FR]; 1, route de la Brosse, F-45720 Coullons (FR). **BEEUWSAERT, Michel** [FR/FR]; 1010, Chemin des Tailles, F-45500 Nevoy (FR). **DUCHAMP, Loïc** [FR/FR]; 27, résidence Croix Saint Simon, F-45500 Gien (FR).
- (74) Agents: **JOLLY, Jean-Pierre** et al.; Cabinet Jolly, 54, rue de Clichy, F-75009 Paris (FR).
- (81) Designated States (unless otherwise indicated, for every kind of national protection available): AE, AG, AL, AM, AT, AU, AZ, BA, BB, BG, BR, BW, BY, BZ, CA, CH, CN, CO, CR, CU, CZ, DE, DK, DM, DZ, EC, EE, EG, ES, FI, GB, GD, GE, GH, GM, HR, HU, ID, IL, IN, IS, JP, KE, KG, KP, KR, KZ, LC, LK, LR, LS, LT, LU, LV, MA, MD, MG, MK, MN, MW, MX, MZ, NA, NI, NO, NZ, OM, PG, PH, PL, PT, RO, RU, SC, SD, SE, SG, SK, SL, SY, TJ, TM, TN, TR, TT, TZ, UA, UG, US, UZ, VC, VN, YU, ZA, ZM, ZW.
- (84) Designated States (unless otherwise indicated, for every kind of regional protection available): ARIPO (BW, GH, GM, KE, LS, MW, MZ, NA, SD, SL, SZ, TZ, UG, ZM, ZW), Eurasian (AM, AZ, BY, KG, KZ, MD, RU, TJ, TM), European (AT, BE, BG, CH, CY, CZ, DE, DK, EE, ES, FI, FR, GB, GR, HU, IE, IT, LU, MC, NL, PL, PT, RO, SE, SI, SK, TR), OAPI (BF, BJ, CF, CG, CI, CM, GA, GN, GQ, GW, ML, MR, NE, SN, TD, TG).
- Declaration under Rule 4.17:**
— of inventorship (Rule 4.17(iv)) for US only
- Published:**
— with international search report
- For two-letter codes and other abbreviations, refer to the "Guidance Notes on Codes and Abbreviations" appearing at the beginning of each regular issue of the PCT Gazette.

(54) Title: ELEVATOR CAR GUIDING DEVICE FOR AN ELEVATOR WITHOUT MACHINE ROOM

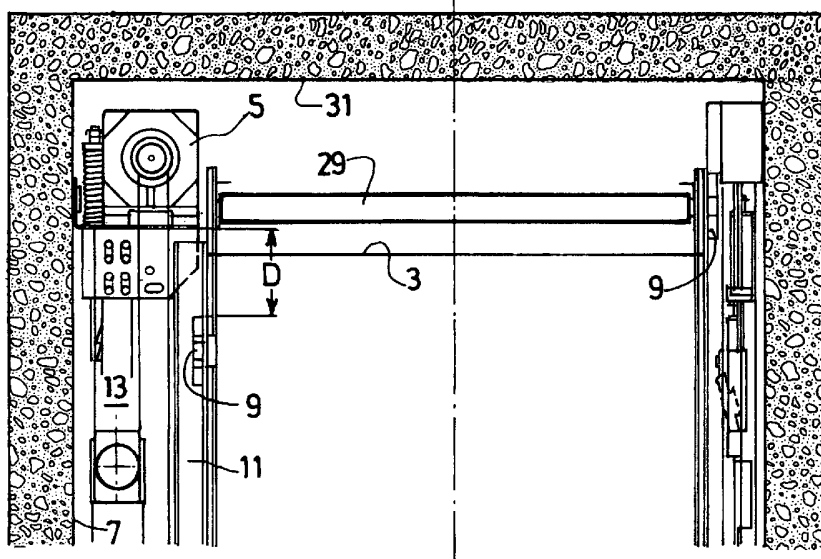

(57) Abstract: The invention relates to an Elevator car (3) guiding device for an elevator without a machine room and with a drive motor (5) mounted on a top side wall of the shaft, wherein the elevator car (3) is guided by means of opposed top and bottom guide elements (9) integral therewith and sliding or rolling on car guide rails (11), characterized in that at least the top car guide element (9) standing in the vertical projection of the drive motor (5) or of the bracket thereof is attached to the car (3) at a lower height than the opposite guide element (9), so as to enable the translation of the car (3) in the shaft (7) at a higher height where the upper part (29) of the car can stand opposite the drive motor (5) or the bracket thereof.

WO 2006/010992 A1

ELEVATOR CAR GUIDING DEVICE FOR AN ELEVATOR WITHOUT MACHINE ROOM

5 This invention relates to an elevator car guiding device for an elevator without machine room and with a drive motor mounted on a top side wall of the shaft, and to the elevator equipped therewith.

10 Elements for the sliding guidance of the elevator car on car guide rails are known to be conventionally placed opposite each other at the same height and at the upper and lower ends of the car, respectively, to provide for a maximum distance between the centre lines of guiding members. However, in elevators with no machine room and a drive motor mounted at the top of a side wall, the top slide guide element of the car on the drive motor side may limit the car's displacement in height in the shaft, as this element protruding laterally may stand in the vertical projection of the motor or of the bracket thereof.

15 The invention aims at correcting this disadvantage and provides an elevator car guiding device for an elevator without a machine room and with a drive motor mounted on a top side wall of the shaft, wherein the elevator car is guided by means of opposed top and bottom guide elements integral therewith and sliding or rolling on car guide rails, characterized in that at least the top car guide element standing in the vertical projection of the drive motor or of the bracket thereof is attached to the car at a lower height than the opposite guide element, so as to enable the translation of the car in the shaft at a higher height where the upper part of the car can stand opposite the drive motor or the bracket thereof.

20 The down height offset of said top guide element on the motor side is of about 0.2 to 0.5m relative to the height of the opposite top guide element, so that the reduced distance between centre lines as compared to a conventional vertical centre line distance, which amounts to 2.2 to 3m according to the car's size, is small and has little impact on the guidance of the elevator car on the motor side, while guidance remains unchanged as in the conventional form on the opposite side.

25 The offset also includes a distance margin D making up for any abnormal car overtravel.

30
35

This arrangement as per the invention has the effect that the car can be brought to the top level with a height close to the top of the elevator shaft, which therefore does not have to be built higher.

Said guide element can be a slide with a U-shaped recess accommodating the corresponding car guide rail in a sliding way, or a roller guide rolling on the car rail.

Said offset guide element is advantageously mounted on a cross-beam attached to the posts of the car frame or arch, which cross-beam is provided with a recess or an inner deformation at the level of the guide element, so that said element stands out as little as possible from the side of the elevator car.

The invention also relates to an elevator equipped with the car guide device as defined above by the invention.

The invention is illustrated below with an exemplary embodiment, referring to the appended drawings in which:

Figure 1 is a perspective view of the car frame with guiding slides;

Figure 2 is a top view showing the assembly of the car slide offset in height on its cross-beam; and

Figure 3 is a cross-sectional view of the shaft showing the position of the car at the top level in the shaft.

The figures, and particularly Figures 1 and 3, respectively represent the arch of the car 1 of an elevator without a machine room, wherein the car 3 and the counterweight are driven by the top-side motor 5 (Figure 3) arranged on top of the shaft 7 and on the side thereof. The motor 5 is compact and has a longitudinal shape along the side of the shaft and horizontally, but its vertical projection impinges on the area of the car guide slides 9 on the motor side.

The motor 5 is mounted on top of a car guide rail 11 and of two opposite counterweight rails 13 between which the counterweight slides on the same side (not shown).

The elevator car 3 bears four guide slides 9, two at the top and two at the bottom, which are arranged in the same vertical plane of the car. These slides 9 with a conventional U-shaped cross-section slide on the two car guide rails 11 that face each other on either side of the car. The bottom slides 9 are conventionally attached on the vertical skirt 15 of the car frame platform and opposite each other at the lower end of the car (and at the same height).

The slide 9 opposite the top slide 9 on the motor side is also conventionally mounted at the upper end of the elevator car on a top cross-beam that is mounted at its ends on the posts 19 of the car arch.

5 The top slide 9 on the motor side is offset downwards relative to the opposite slide by about 0.4m, and therefore relative to the conventional position at the upper end of the elevator car.

10 This offset is small relative to the conventional centre lines distance of the slides, which is of about 2.2m in this case, and has little impact on the quality of car guidance relative to guidance with conventionally spaced slides.

The slide 9 offset in height is mounted on its own cross-beam 21 attached by its ends to the car arch posts 19 at the desired height.

15 This cross-beam 21 is bent (Figure 2) to form an inner recess 23 accommodating the slide. This recess 23 delimited by two opposite wings 25 inclined inwards is flat and can accommodate the slide on its length, at a variable point along its length according to the position of the slide on the car. The wall of the cross-beam turned inwards is located close to the panels 27 of the car, which limits the depth of the inner recess. This recess 23 allows reducing the outwards protrusion of the slide outside the car, and thus bringing the corresponding rail guide 11 closer, with the possibility to reduce the cross-sectional surface of the shaft.

25 Owing to this offset arrangement in height of the slide, the car can ascend to a top level, as seen on Figure 3, in a position where its upper part 29 (beam) stands opposite the motor 5, and therefore within a small distance from the shaft ceiling 31, without this ascension of the car being hindered by the top slide. A distance margin D between the slide and the motor, e.g. 0.15m, must be provided to take account of any car rebound phenomenon or of a drive failure causing the car to travel beyond its normal limits.

30 The slides 9 can obviously be replaced by roller guide elements rolling on the car guide rails.

CLAIMS

1. Elevator car (3) guiding device for an elevator without a machine room and with a drive motor (5) mounted on a top side wall of the shaft, wherein the elevator car (3) is guided by means of opposed top and bottom guide elements (9) integral therewith and sliding or rolling on car guide rails (11), characterized in that at least the top car guide element (9) standing in the vertical projection of the drive motor (5) or of the bracket thereof is attached to the car (3) at a lower height than the opposite guide element (9), so as to enable the translation of the car (3) in the shaft (7) at a higher height where the upper part (29) of the car can stand opposite the drive motor (5) or the bracket thereof.

2. Guiding device as per claim 1, characterized in that the down height offset of said top guide element (9) on the motor side is of about 0.2 to 0.5m relative to the height of the opposite top guide element (9), so that the reduced distance between centre lines as compared to a conventional vertical centre lines distance, i.e. about 2.2 to 3m, is small.

3. Guiding device as per claim 2, characterized in that said offset also includes a distance margin D making up for any abnormal car overtravel.

4. Guiding device as per claim 1, 2 or 3, characterized in that said guide element (9) is a slide with a U-shaped recess accommodating the corresponding car guide rail (11) in a sliding way.

5. Guiding device as per any one of claims 1 to 3, characterized in that said guide element (9) is a roller-type guide rolling on the car guide rail (11).

6. Guiding device as per any one of the preceding claims, characterized in that said guide element (9) is mounted on a cross-beam (21) attached to the posts (19) of the car frame or arch (1), which cross-beam (21) is provided with a recess or an inner deformation (23) at the level of the guide element (9), so that said element stands out as little as possible from the side of the elevator car (3).

7. Elevator characterized in that it is equipped with a guiding device as defined in any one of the preceding claims.

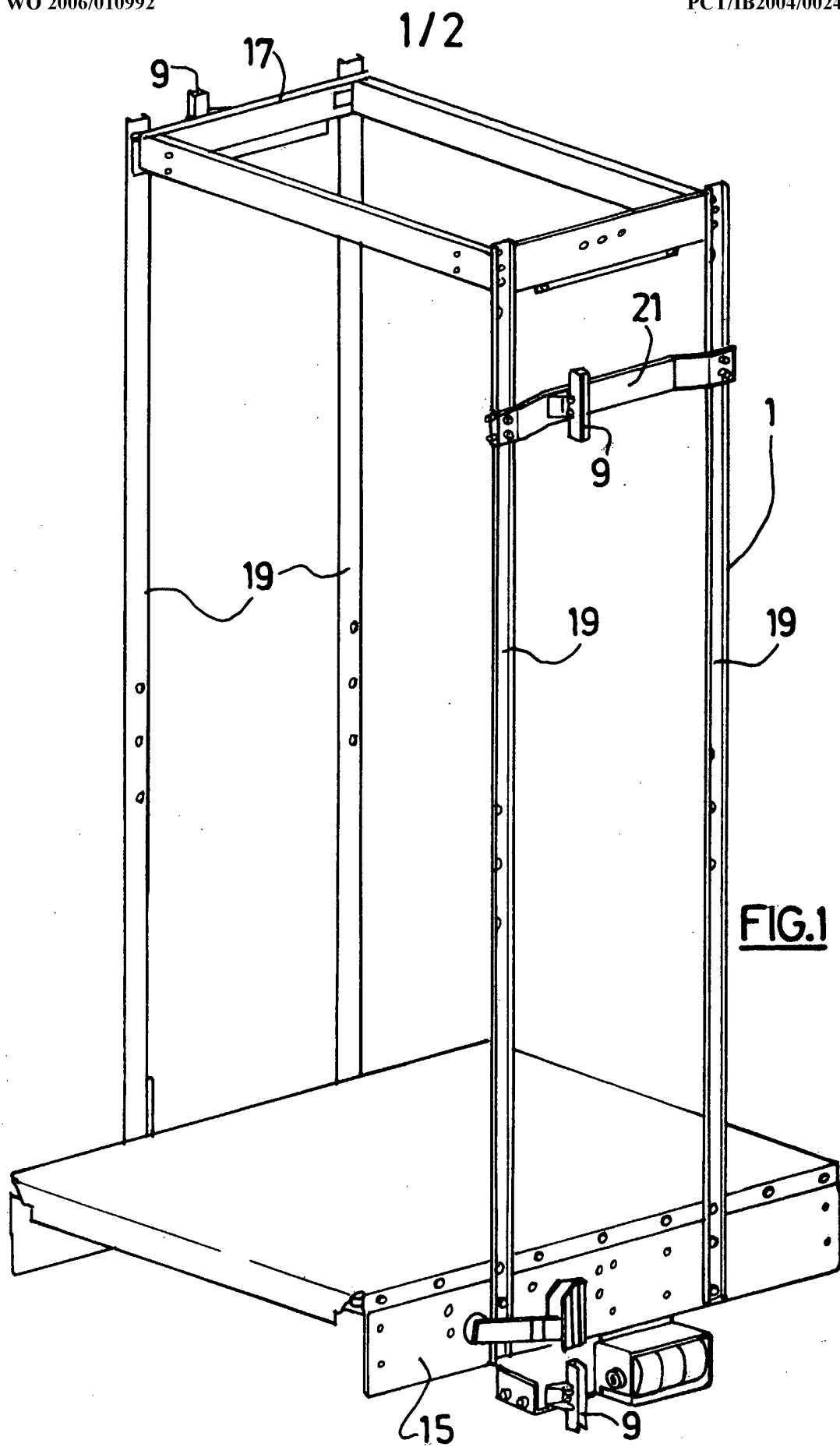

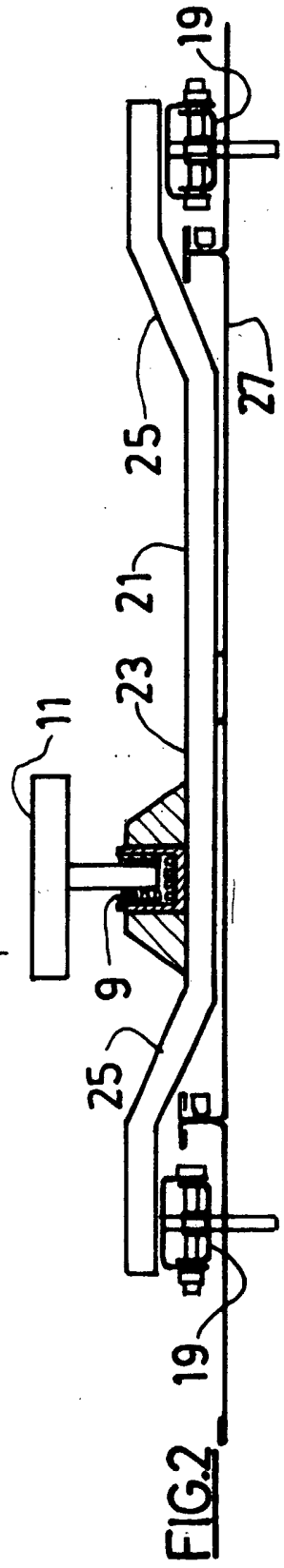
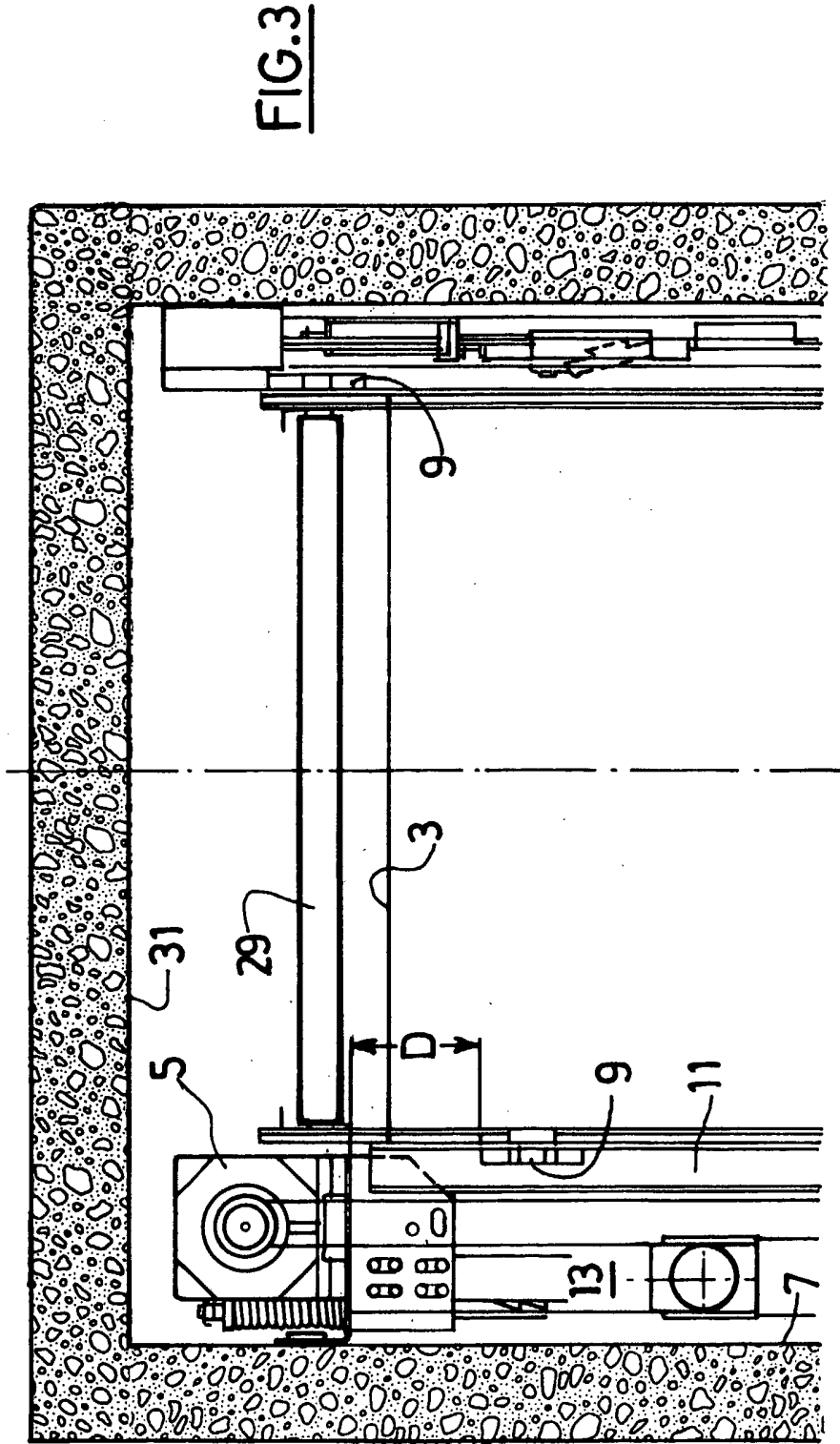

INTERNATIONAL SEARCH REPORT

IB2004/002416

A. CLASSIFICATION OF SUBJECT MATTER IPC 7 B66B7/04		
According to International Patent Classification (IPC) or to both national classification and IPC		
B. FIELDS SEARCHED		
Minimum documentation searched (classification system followed by classification symbols) IPC 7 B66B		
Documentation searched other than minimum documentation to the extent that such documents are included in the fields searched		
Electronic data base consulted during the international search (name of data base and, where practical, search terms used) EPO-Internal, PAJ, WPI Data		
C. DOCUMENTS CONSIDERED TO BE RELEVANT		
Category °	Citation of document, with indication, where appropriate, of the relevant passages	Relevant to claim No.
A	US 2003/111302 A1 (UTSUNOMIYA KENJI ET AL) 19 June 2003 (2003-06-19) abstract; figure 1	1
A	----- US 3 425 516 A (MINEJIRO JIN ET AL) 4 February 1969 (1969-02-04) abstract; figure 1 -----	1
<input type="checkbox"/> Further documents are listed in the continuation of box C. <input checked="" type="checkbox"/> Patent family members are listed in annex.		
° Special categories of cited documents :		
"A" document defining the general state of the art which is not considered to be of particular relevance	"T" later document published after the international filing date or priority date and not in conflict with the application but cited to understand the principle or theory underlying the invention	
"E" earlier document but published on or after the international filing date	"X" document of particular relevance; the claimed invention cannot be considered novel or cannot be considered to involve an inventive step when the document is taken alone	
"L" document which may throw doubts on priority claim(s) or which is cited to establish the publication date of another citation or other special reason (as specified)	"Y" document of particular relevance; the claimed invention cannot be considered to involve an inventive step when the document is combined with one or more other such documents, such combination being obvious to a person skilled in the art.	
"O" document referring to an oral disclosure, use, exhibition or other means	"&" document member of the same patent family	
"P" document published prior to the international filing date but later than the priority date claimed		
Date of the actual completion of the international search 4 July 2005	Date of mailing of the international search report 20. 10. 2005	
Name and mailing address of the ISA European Patent Office, P.B. 5818 Patentlaan 2 NL - 2280 HV Rijswijk Tel. (+31-70) 340-2040, Tx. 31 651 epo nl, Fax: (+31-70) 340-3016	Authorized officer Nelis, Y	

INTERNATIONAL SEARCH REPORT

IB2004/002416

Patent document cited in search report	Publication date	Patent family member(s)	Publication date	
US 2003111302	A1	19-06-2003	WO 02083543 A1 TW 522133 B	24-10-2002 01-03-2003
US 3425516	A	04-02-1969	GB 1091058 A	15-11-1967