

A. WOLLENSAK.
 PHOTOGRAPHIC SHUTTER.
 APPLICATION FILED, MAR. 2, 1911.

997,530.

Patented July 11, 1911.

4 SHEETS—SHEET 1.

Fig. 1.

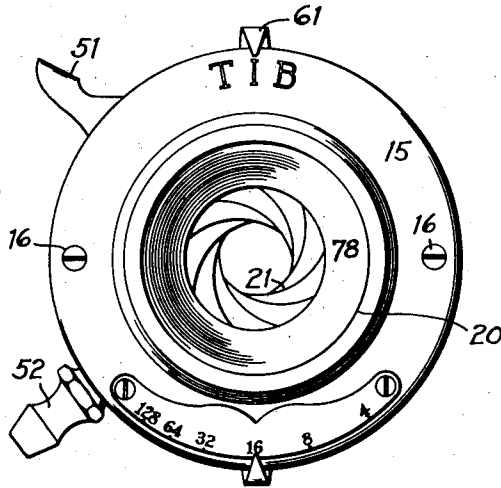

Fig. 2.

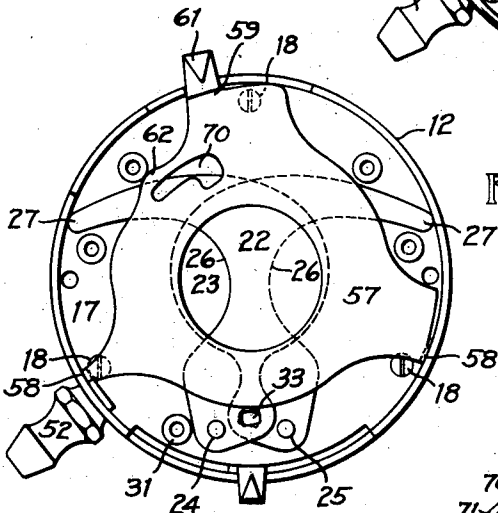
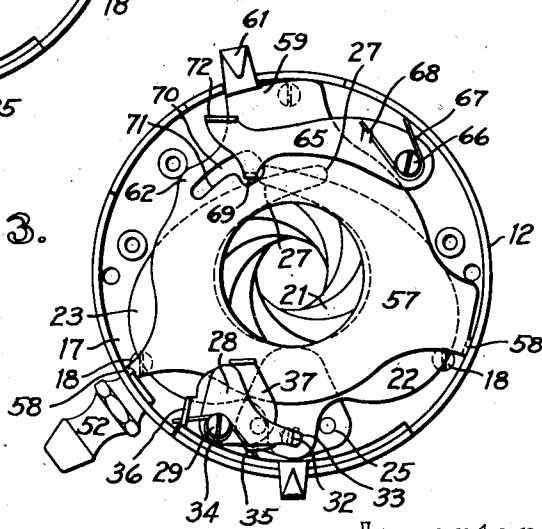

Fig. 3.



Witnesses:
 W. Gurnee
 C. W. Carroll

Inventor:
 Andrew Wollensak
 by his attorneys
 Cogood, Davis & Dorsey

997,530.

Patented July 11, 1911.

4 SHEETS—SHEET 2.

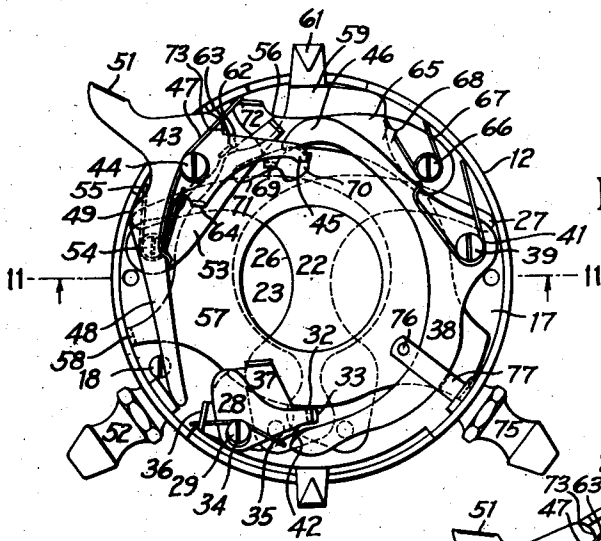

Fig. 4.

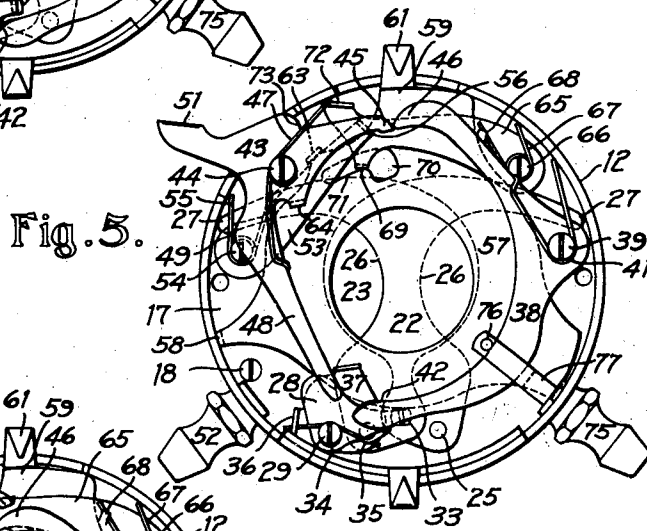

Fig. 5.

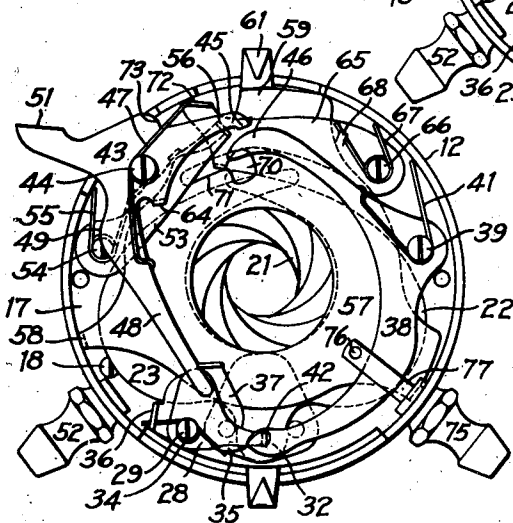

Fig. 6.

Witnesses:
D. Gurnee
C. W. Carroll

Inventor:
Andrew Wollensak
by his attorneys
C. Good, Davis & Dorsey

A. WOLLENSAK.
 PHOTOGRAPHIC SHUTTER.
 APPLICATION FILED MAR. 2, 1911.

997,530.

Patented July 11, 1911.

4 SHEETS-SHEET 3.

Fig. 7.

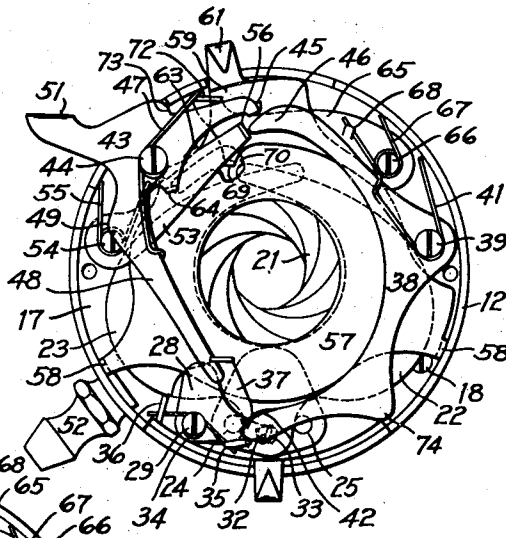

Fig. 8.

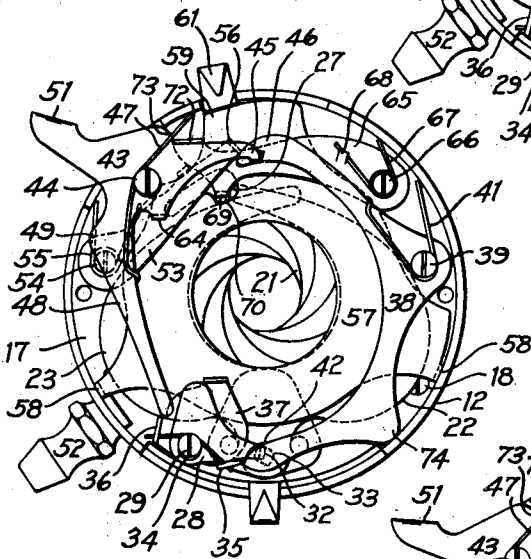
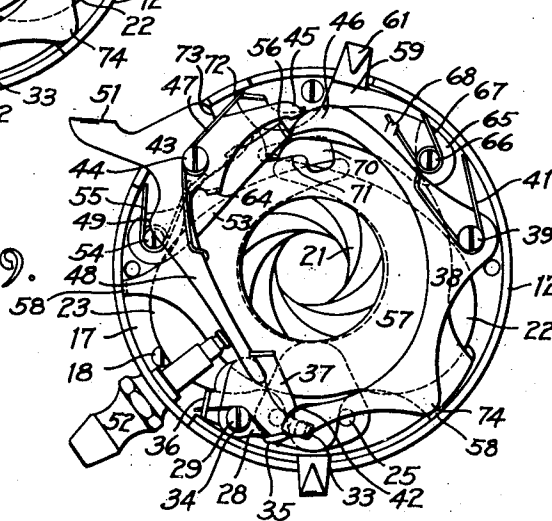

Fig. 9.



Witnesses:
 W. Gurnee
 C. W. Carroll

Inventor:
 Andrew Wollehsak
 by his attorneys
 Cogood, Davis & Dorsey

A. WOLLENSAK.
 PHOTOGRAPHIC SHUTTER.
 APPLICATION FILED MAR. 2, 1911.

997,530.

Patented July 11, 1911.

4 SHEETS—SHEET 4.

Fig. 10.

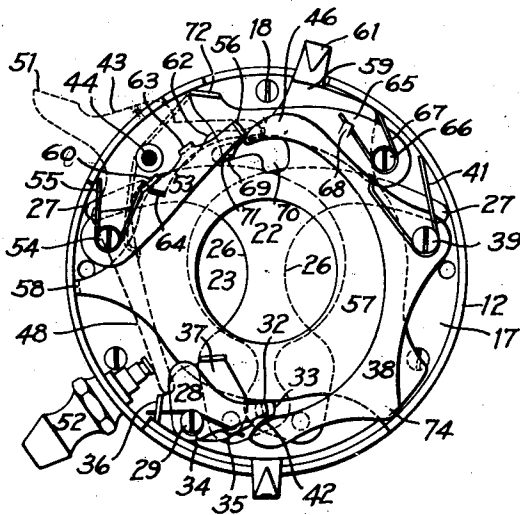
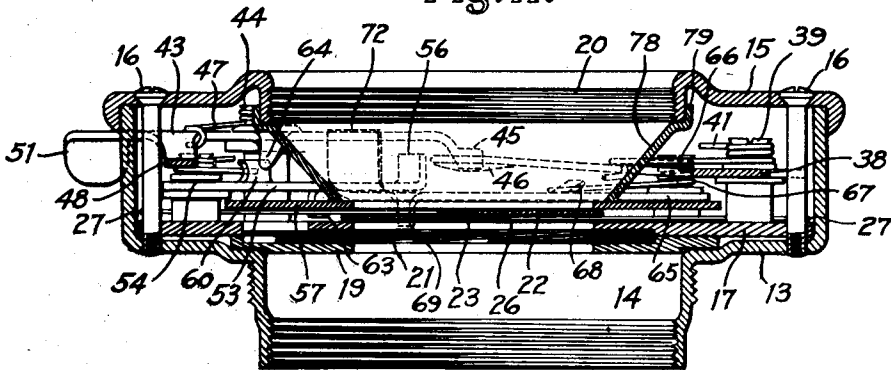

Fig. 11.



Witnesses:
 H. Gurnee
 C. W. Carroll

Inventor:
 Andrew Wollesak
 by his attorneys
 Cogood, Davis & Dorsey

UNITED STATES PATENT OFFICE.

ANDREW WOLLENSAK, OF ROCHESTER, NEW YORK, ASSIGNOR TO WOLLENSAK OPTICAL COMPANY, OF ROCHESTER, NEW YORK, A CORPORATION OF NEW YORK.

PHOTOGRAPHIC SHUTTER.

997,530.

Specification of Letters Patent. Patented July 11, 1911.

Application filed March 2, 1911. Serial No. 611,951.

To all whom it may concern:

Be it known that I, ANDREW WOLLENSAK, a citizen of the United States, and resident of Rochester, in the county of Monroe and State of New York, have invented certain new and useful Improvements in Photographic Shutters, of which the following is a specification.

This invention relates to shutters of the type adapted to produce exposures of different kinds, such as are commonly designated as "instantaneous", "bulb", and "time" exposures.

The object of the invention, generally stated, is to produce a shutter of the kind in question which shall be simple and inexpensive in construction and reliable in operation.

A feature of the invention consists in the employment of a detent acting directly upon one of the shutter-blades to arrest the blades in open position, whereby the mechanism is simplified and the number of operative parts reduced.

Another feature of the invention consists in the use of a controlling-member in the form of a rotatably-mounted plate, which is so arranged as to perform also the function of a closure for the portion of the shutter-casing in which the blades move.

Other features of the invention, relating to the construction and the coöperative relation of the various parts, will be set forth in connection with the following description of the illustrated embodiment of the invention.

In the accompanying drawings: Figure 1 is a front-elevation of the complete shutter; Fig. 2 is a rear-elevation of the shutter, with the blade-actuating mechanism removed; Fig. 3 is a rear-elevation with certain portions of the blade-actuating mechanism in place, including the time-detent and the blade-actuating lever; Fig. 4 is a rear-elevation of the complete shutter in a slightly modified form with the parts in normal position; Figs. 5 and 6 are rear-elevations of the same showing two positions of the parts assumed in the production of an instantaneous exposure; Figs. 7 and 8 are rear-elevations showing two positions assumed by the parts in the production of a time-exposure; Figs. 9 and 10 are rear-elevations showing two positions assumed by the parts in the production of a bulb-exposure; and

Fig. 11 is an enlarged section on the line 11—11 in Fig. 4.

The illustrated embodiment of the invention is a shutter of the "between the lenses" type, having the general form familiar in such shutters. It has a casing 12 of generally-cylindrical form, provided with a flat back 13, and a threaded rearward extension or nipple 14 by which it is secured to the camera-front, and in which the rear element of the lens is mounted. The front of the casing is closed by a plate 15, secured in place by screws 16 and provided with a threaded central nipple 20 to receive the front element of the lens. A base-plate 17 is secured to the back 13 of the casing by screws 18, and between the base-plate and the back is mounted an iris-diaphragm comprising a rotatable ring 19 and blades 21. This diaphragm is a usual adjunct of shutters of this type, and constitutes no part of the present invention.

Two shutter-blades 22 and 23 are employed, of a well-known crescent form, as shown particularly in Fig. 2. These blades are pivoted upon studs 24 and 25 projecting forwardly from the base-plate 17. The blades have semi-circular concave edges 26 between which the exposure aperture is produced when the blades are in open position, as in Fig. 3. In the closed position of the blades their free extremities 27 rest against the inner surface of the casing 12. The shutter-blades are opened and closed by means of a blade-actuating lever 28 (Fig. 3), which is pivoted on a screw 29 threaded into a boss 31 on the base-plate. This lever has a lug 32 which engages elongated openings 33 in the shutter-blades. A spring 34 coiled around the screw 29 engages, at one end, a second lug 35 on the lever, while the other end of the spring rests against a lug 36 on a plate 37. The plate 37 is fixed on the boss 31 beneath the lever 28, and is prevented from rotating by engagement with the stud 24. The spring 34 tends constantly to swing the actuating-lever to the left, and thereby to close the shutter-blades. The blade-actuating lever is moved to open the blades by means of a master-lever 38 (Fig. 4), which is pivoted upon a screw 39 entering a boss on the base-plate. A spring 41 coiled about the screw 39 engages the master-lever at one end, and the casing 12 at its other end, and tends to swing the mas-

ter-lever to the left and into the position of Fig. 4. At its lower end the master-lever has a forwardly-bent lip 42, and when the master-lever is swung to the right, against the opposition of the spring 41, this lip rides over the lug 35 on the actuating-lever. Upon the subsequent release and return movement of the master-lever, its lower edge catches upon the lug 35, thereby swinging the actuating-lever to the right and opening the shutter-blades. As this movement continues, however, the master-lever finally rides off from the end of the lug 35, as shown in Fig. 6, so that the actuating-lever is permitted to swing back and close the shutter-blades. The master-lever is actuated by means of an operating-lever 43 which is pivoted on a screw 44 entering a boss on the base-plate. This lever is provided with a hooked extremity 45 which co-operates with the upper end 46 of the master-lever (Figs. 4 and 11). A spring 47 coiled about the screw 44 engages the lower arm 48 of the operating-lever, and holds it normally in the position of Fig. 4, with a projection 49 on the lever in engagement with the inner surface of the casing. The operating-lever is provided with a thumb-piece 51 for direct manual operation, and its arm 48 is also in a position to be actuated by a pneumatic device 52 of well-known form.

In the production of an instantaneous exposure the operating-lever 43 is swung to the left by the operator, thereby causing its hooked extremity 45 to engage and raise the end 46 of the master-lever to the position of Fig. 5, and then slip off from the master-lever. The latter then returns under the influence of the spring 41 and operates the blade-actuating lever in the manner above described, thereby causing the blades to quickly open and close again. When the operating-lever is released by the operator and returns to normal position, the hook 45 rides idly over the extremity 46 of the master-lever, the latter being beveled (Fig. 11) for this purpose.

To produce a bulb-exposure, the shutter is provided with a detent, hereinafter designated as a "bulb-detent". This member is in the form of an arm 53 pivoted on a screw 54 entering a boss on the base-plate. A spring 55, coiled about the screw, engages a lug 60 (Fig. 10) on the detent, and tends to throw the detent downward into the operative position shown in Fig. 7. In this position a lug 56, on the end of the detent, co-operates with the extremity 46 of the master-lever, to arrest the latter after it has moved far enough to open the shutter-blades wide, and before it has disengaged the blade-actuating lever to permit the blades to close again. The bulb-detent is held out of operative position, when the shutter is

set for instantaneous exposures, by means of a controller by which the shutter is set for its several exposure actions. This controller is in the form of a plate 57 (Fig. 2), which is provided with rearward projections 58 bearing both against the base-plate 17 and against the inner surface of the casing 12. The controller is provided also with an upward projection 59 bearing against the casing and terminating in a finger-piece 61 by which the controller may be moved. The finger-piece projects outward through a slot in the casing, and its position is indicated by letters on the front of the casing (Fig. 1) in the usual manner. The controller 57 is provided, upon its edge, with a cam-projection 62 (Figs. 2 and 10), which co-operates with a rearwardly-projecting lug 63 on the bulb-detent. In the middle position of the controller (Figs. 4, 5 and 6), in which it is set for instantaneous exposure, the cam-projection holds the bulb-detent in raised, inoperative position, but when the controller is moved to the right to produce a bulb-exposure (Figs. 9 and 10) the bulb-detent is released. Fig. 9 shows the position of the parts after the operating-lever has been swung to the left by the action of the bulb and while the bulb is still under compression, thereby holding the shutter open. As shown, the operating-lever, having raised the extremity 46 of the master-lever, has finally passed off therefrom, and the master-lever, in its return movement, has swung the blade-actuating lever to the right sufficiently to open the shutter-blades. At this time the master-lever is arrested by the bulb-detent and the shutter remains open. Upon the subsequent release of the bulb the operating-lever swings to the right, and in doing so it raises the bulb-detent out of engagement with the master-lever. For this purpose the operating-lever is provided with a rearwardly-projecting lug 64. This lug is shown in section in Fig. 10, the body of the operating-lever being in dotted lines to disclose more clearly the parts beneath. The lug 64 engages the lug 60 on the detent and thus raises the detent. Fig. 10 illustrates the position of the parts assumed during this return movement of the operating-lever and at the point where the detent has released the master-lever and the blades have closed, but before the completion of the return movement of the operating-lever.

To produce time-exposures the shutter is provided with a second detent, hereinafter designated as a time-detent. This member is in the form of an arm 65 (Figs. 3, 7 and 8), which is pivoted on a screw 66 entering a boss on the base-plate. A spring 67 coiled about the screw engages a lug 68 on the time-detent, and tends to swing the latter downward into operative position. The time-detent is arranged to co-operate directly with

one of the shutter-blades, having a lug 69 which projects rearwardly through a hole 70 in the controller 57 and into the space traversed by the blade 22. The hole 70 is elongated so as to provide a shoulder 71, and when the controller is set for instantaneous or bulb-exposures this shoulder engages the lug 69 and holds the time-detent in raised, inoperative position. When the controller is moved to the left, however, into the position for time-exposures, the time-detent is released and it descends into engagement with the upper edge of the blade 22. At this time the bulb-detent is also free to operate, as the cam-projection 62 is at the left of the lug 63 on the detent. With the parts set for a time-exposure, when the operating-lever is moved to the left the master-lever is first raised and then released, as before described, thus throwing the blade-actuating lever into open position, and the master-lever is then arrested in its return movement by the bulb-detent (Fig. 7). In this position of the parts the upper extremity of the blade 22 is at the right of the lug 69 on the time-detent. Upon the subsequent release of the operating-lever, the first part of its return movement raises the bulb-detent, as in a bulb-exposure, thereby releasing the master-lever, which thereupon completes its return movement and disengages the blade-actuating lever. The blades do not, however, return to closed position, for the extremity 27 of the blade 22 is arrested, after a very short movement, by engagement with the lug 69 on the time-detent, and the shutter thus remains open. At this time the operating-lever is prevented from returning fully to normal position, by means of a lug 72 on the time-detent which engages a shoulder 73 on the operating-lever. The hook 45 on the latter is thus prevented from riding over the extremity 46 of the master-lever, so that upon the succeeding operation of the operating-lever, to close the shutter, the master-lever is not again actuated. With the parts in the position just described, the shutter may be closed by a second operation of the operating-lever. This movement causes the operating-lever to raise the time-detent out of engagement with the blade 22, through the engagement of the horizontal arm of the lever with the lug 72 on the detent, and the blades are thus released and returned at once to closed position. When the operating-lever is now released it is not arrested by the lug 72, owing to the fact that the time-detent rests upon the upper edge of the blade 22 and the lug 72 is thus held above the shoulder 73 on the operating-lever, so that the operating-lever returns to normal position.

The illustrated embodiment of the invention is not designed to produce instantaneous exposures of different lengths, although it

may readily be adapted to that purpose. In its simplest form the master-lever is provided with a projection 74 (Fig. 8), which engages the inner surface of the casing and arrests the master-lever in normal position. The instantaneous exposure in this case is determined merely by the time required by the mechanism to perform its cycle of operations. In some cases, however, particularly in hand-cameras, it is desirable to provide for an instantaneous exposure of longer duration, and in such cases a pneumatic retarding-device may be provided for the master-lever. This retarder may be applied as shown in Figs. 4, 5, and 6, where a pneumatic cylinder 75 of well-known form is screwed into the casing and provided with a plunger 77 which is slotted to receive the lower arm of the master-lever. A pin 76 in the inner extremity of the plunger is engaged by the master-lever (Fig. 5) when the latter is raised by the operating-lever, and the plunger is thus drawn inwardly. During the return movement of the master-lever it first moves freely in the slot until it has moved the shutter-blades to wide-open position. At this point, however, the master-lever reaches the end of the slot, shown in dotted lines in Figs. 4, 5 and 6, so that the further movement of the lever is retarded by the pneumatic action. As soon as this has been overcome, however, the master-lever slips off from the blade-actuating lever and the blades are immediately closed again. No provision is made for adjusting the action of this pneumatic retarding-device as the shutter, in the simple form described, is intended to give instantaneous-exposures of only a single predetermined length, and the action of the retarding-device is determined, therefore, by the diameter of its piston and the closeness with which the piston is fitted.

The space between the front-plate 15 and the controller-plate 57 is closed by a thimble 78 having, at its forward extremity, a rim 79 which is frictionally retained upon the end of the nipple 20 on the front-plate. This construction permits the thimble to be removed and replaced by another with a smaller aperture when it is desirable to provide the shutter with a fixed aperture of limited size.

By arranging the time-detent to cooperate directly with the shutter-blade I have produced a mechanism of an unusually simple character. The arrangement of the parts is novel also in the respect that in the intermediate position of the controller the shutter produces an instantaneous exposure, while the bulb-detent is thrown into operation when the controller is thrown to either side of its intermediate position, thus producing, respectively, time exposures and bulb-exposures. The arrangement of the controller-plate 57 is also a novel and valuable feature

of the invention, since this member acts both as a controller and as a closure for the space occupied by the shutter-blades, thus simplifying and cheapening the construction of the shutter.

My invention is not limited to the embodiment thereof hereinbefore described and illustrated in the accompanying drawings, but it may be embodied in various other forms within the nature of the invention as it is defined in the following claims.

I claim:—

1. A shutter having, in combination, a casing, pivoted shutter-blades, blade-actuating mechanism inclosed in said casing and comprising a detent, and a plate rotatably mounted in the casing between the blades and said mechanism, and constituting both an inclosure for the blades and a controller for the mechanism, said plate having a cam surface cooperating with said detent to determine the character of the exposure according to the position of the plate.

2. A shutter having, in combination, a casing, a plate rotatably mounted in the casing close to the back thereof, shutter-blades inclosed and movable between said plate and the back of the casing, and blade-actuating mechanism in the casing in front of said plate, comprising time and bulb-detents, the plate having cam-surfaces engaging said detents to control their operation in accordance with the position of the plate.

3. A shutter having, in combination, a pivoted blade, mechanism for opening and closing the blade, a detent normally tending to cooperate directly with the blade and engage it, in its open position, to prevent closing movement of the blade, and an operating-member connected with and actuating the blade-actuating mechanism during movement in one direction and cooperating in its return movement with the detent to disengage the latter from the blade and permit the blade to close.

4. A shutter having, in combination, a pivoted blade, mechanism for opening and closing the blade, a detent cooperating directly with the blade and engaging it, in its

open position, to prevent closing movement of the blade, and an operating-lever connected with and actuating the blade-actuating mechanism, the operating-lever having an abutment engaged by the detent to arrest the return movement of the operating-lever, and the detent having an abutment engaged by the operating lever whereby the detent is disengaged from the blade when the operating-lever performs its operating movement.

5. A shutter having, in combination, a pivoted blade, mechanism, including a master-lever, for opening and closing the blade, an operating-lever cooperating with the master-lever, when moved in one direction, to actuate the blade, the operating-lever having a return movement which is idle with respect to the master-lever, a bulb-detent normally cooperating with the master-lever to arrest the return movement thereof after the shutter-blade has been moved thereby to open position, a time-detent adapted to cooperate directly with the shutter-blade and to engage it in its open position to prevent closing movement thereof, and cooperating abutments on the operating-lever and both of said detents whereby the operating-lever trips the time-detent in its operating movement and the bulb-detent in its return movement.

6. A shutter having, in combination, a pivoted shutter-blade, actuating-mechanism for opening and closing the blade, a bulb-detent and a time-detent normally operating successively to prevent closing movement of the blade, and a controller for determining the character of the exposure; said controller, when in its median position, engaging and holding both detents in inoperative position; when moved to one side of its median position, engaging and holding the time-detent in inoperative position and releasing the bulb-detent; and when moved to the other side of its median position, disengaging and releasing both detents.

ANDREW WOLLENSAK.

Witnesses:

D. GURNEE,
L. THON.