



(51) International Patent Classification:
H02K 29/00 (2006.01)

(21) International Application Number:

PCT/CN2018/076826

(22) International Filing Date:

14 February 2018 (14.02.2018)

(25) Filing Language:

English

(26) Publication Language:

English

(71) Applicant: **TTI (MACAO COMMERCIAL OFFSHORE) LIMITED** [CN/CN]; Units A-C, 26/F Centro Comercial da Praia Grande No. 429 Avenida da Praia Grande, Macao (CN).

(72) Inventors: **LEE, Hei Man**; 29/F, Tower 2, Kowloon Commerce Centre, 51 Kwai Cheong Road, Kwai Chung, Hong Kong (CN). **WANG, Nan**; No.1, Chuang Ke Road Houjie Town Industrial Park, Houjie Town, Dongguan, Guangdong 523000 (CN).

(74) Agent: **RUNPING & PARTNERS**; Suite 515, Yingu Mansion, No.9 Beisihuanxilu, Haidian District, Beijing 100190 (CN).

(81) Designated States (unless otherwise indicated, for every kind of national protection available): AE, AG, AL, AM, AO, AT, AU, AZ, BA, BB, BG, BH, BN, BR, BW, BY, BZ, CA, CH, CL, CN, CO, CR, CU, CZ, DE, DJ, DK, DM, DO, DZ, EC, EE, EG, ES, FI, GB, GD, GE, GH, GM, GT, HN, HR, HU, ID, IL, IN, IR, IS, JO, JP, KE, KG, KH, KN, KP, KR, KW, KZ, LA, LC, LK, LR, LS, LU, LY, MA, MD, ME, MG, MK, MN, MW, MX, MY, MZ, NA, NG, NI, NO, NZ,

OM, PA, PE, PG, PH, PL, PT, QA, RO, RS, RU, RW, SA, SC, SD, SE, SG, SK, SL, SM, ST, SV, SY, TH, TJ, TM, TN, TR, TT, TZ, UA, UG, US, UZ, VC, VN, ZA, ZM, ZW.

(84) Designated States (unless otherwise indicated, for every kind of regional protection available): ARIPO (BW, GH, GM, KE, LR, LS, MW, MZ, NA, RW, SD, SL, ST, SZ, TZ, UG, ZM, ZW), Eurasian (AM, AZ, BY, KG, KZ, RU, TJ, TM), European (AL, AT, BE, BG, CH, CY, CZ, DE, DK, EE, ES, FI, FR, GB, GR, HR, HU, IE, IS, IT, LT, LU, LV, MC, MK, MT, NL, NO, PL, PT, RO, RS, SE, SI, SK, SM, TR), OAPI (BF, BJ, CF, CG, CI, CM, GA, GN, GQ, GW, KM, ML, MR, NE, SN, TD, TG).

Published:

— with international search report (Art. 21(3))

(54) Title: OUTER ROTOR MOTOR

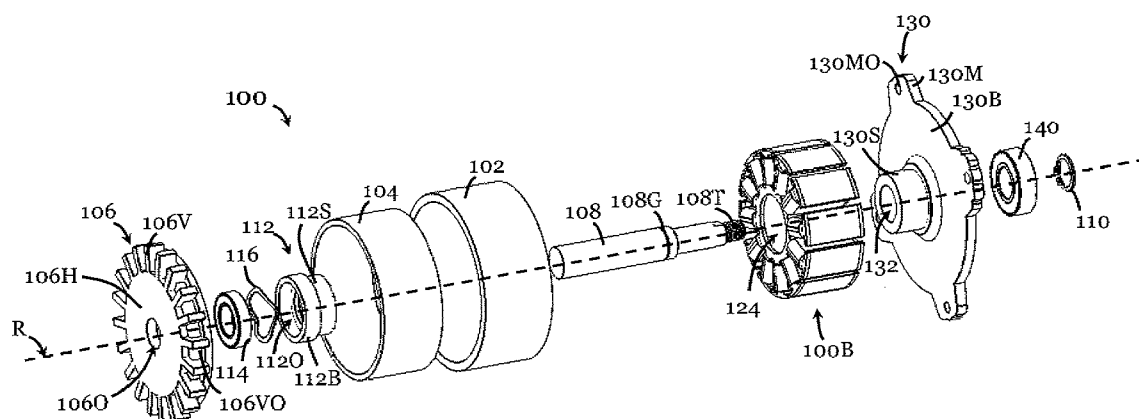

Figure 2

(57) Abstract: An outer rotor motor having a stator and a rotor. The rotor includes a bonded magnet arranged around the stator, with an air-gap arranged between the bonded magnet and the stator.

OUTER ROTOR MOTOR

TECHNICAL FIELD

5 The invention relates to an outer rotor motor.

BACKGROUND

10 An electric motor generally includes a moving part (a rotor) and a stationary part (a stator). The rotor may include multiple permanent magnet pieces and the stator may include multiple windings. Electromagnetic interaction of the permanent magnet pieces with the windings turns the motor shaft to deliver mechanical power.

15 Despite its long history of development, there remains need to improve on motor designs, to provide motors that can be made compact, operationally efficient, and can be assembled, manufactured, and operated cost-effectively.

SUMMARY OF THE INVENTION

20 In a first aspect of the invention, there is provided an outer rotor motor, comprising: a stator; and a rotor including a bonded magnet arranged around the stator, with an air-gap arranged between the bonded magnet and the stator. The bonded magnet may be made of hard magnetic powder and non-magnetic
25 polymer or rubber binder. The hard magnetic powder may be hard ferrite, NdFeB, SmCo, AlNiCo, or combination of two or more of them.

The bonded magnet may be in the form of a hollow cylinder, e.g., in one piece. Preferably, the bonded magnet has circumferentially alternating North
30 and South poles. The number of poles is preferably an even number.

Preferably, the poles are of substantially the same angular extension (i.e., in cross-section, arc length). Alternatively, the poles may have different angular extensions. The magnetization produced by the poles may be a straight
35 magnetization, a skewed magnetization, etc.

Preferably, the rotor further comprises a rotor yoke. The bonded magnet may be mounted around (on an outer surface of) the rotor yoke, in which case the air-gap is arranged between the rotor yoke and the stator. Alternatively, the
40 bonded magnet may be mounted in (on an inner surface of) the rotor yoke, in which case the air-gap is arranged directly between the bonded magnet and the stator. In this case, the air-gap is preferably less than 1.00mm, more preferably about 0.50mm. Optionally, the rotor yoke may be omitted.

45 Preferably, the outer rotor motor further comprises an integrated PCB assembly arranged on one side of the bonded magnet. The integrated PCB assembly may include mounting portions for mounting the outer rotor motor to a support structure. An axial gap may be defined between the bonded magnet and the integrated PCB assembly.
50

Preferably, the rotor further comprises an end cap with vanes, arranged on another side of the bonded magnet opposite the integrated PCB assembly. The vanes may assist with dissipating heat during operation. The end cap may be fixedly connected with the bonded magnet. The end cap may be directly
5 connected with the bonded magnet, or it may be indirectly connected to the bonded magnet through the rotor yoke.

Preferably, the vanes extend radially and are evenly angularly spaced apart. An air flow opening may be arranged between respective adjacent vanes.
10

Preferably, the air-gap, the axial gap, and the air flow openings are in fluid communication to define a cooling air flow path.

Preferably, the rotor further comprises a shaft operably coupled with
15 bonded magnet for rotation. Preferably, the shaft extends through the end cap, the bonded magnet, the stator, and the PCB assembly.

Preferably, the outer rotor motor is a brushless motor. More preferably, the outer rotor motor is a DC brushless motor.
20

In a second aspect of the invention, there is provided a rotor for an outer rotor motor, comprising: a bonded magnet configured to be arranged around a stator and spaced apart from the stator, with an air-gap arranged between the bonded magnet and the stator. The bonded magnet may be made of hard
25 magnetic powder and non-magnetic polymer or rubber binder. The hard magnetic powder may be hard ferrite, NdFeB, SmCo, AlNiCo, or combination of two or more of them.

Preferably, the bonded magnet is in the form of a hollow cylinder, e.g., in one piece. Preferably, the bonded magnet has circumferentially alternating North and South poles. The number of poles is preferably an even number.
30

Preferably, the poles are of substantially the same angular extension (i.e., in cross-section, arc length). Alternatively, the poles may have different angular
35 extensions. The magnetization produced by the poles may be a straight magnetization, a skewed magnetization, etc.

Preferably, the rotor further comprises a rotor yoke. The bonded magnet may be mounted around (on an outer surface of) the rotor yoke, in which case
40 the air-gap is arranged between the rotor yoke and the stator. Alternatively, the bonded magnet may be mounted in (on an inner surface of) the rotor yoke, in which case the air-gap is arranged directly between the bonded magnet and the stator. In this case, the air-gap is preferably less than 1.00mm, more preferably about 0.50mm. Optionally, the rotor yoke may be omitted.
45

Preferably, the rotor further comprises an end cap with vanes, arranged on one side of the bonded magnet. The vanes may assist with dissipating heat during operation. The end cap may be fixedly connected with the bonded magnet, optionally through the rotor yoke.
50

Preferably, the vanes extend radially and are evenly angularly spaced apart. An air flow opening may be arranged between respective adjacent vanes.

5 Preferably, the outer rotor motor is a brushless motor. More preferably, the outer rotor motor is a DC brushless motor.

In a third aspect of the invention, there is provided an outer rotor motor with the rotor of the second aspect.

10 In a fourth aspect of the invention, there is provided an electric appliance or tool comprising the outer rotor motor of the first aspect.

In a fifth aspect of the invention, there is provided an electric appliance or tool comprising the outer rotor motor of the third aspect.

15

BRIEF DESCRIPTION OF THE DRAWINGS

Embodiments of the invention will now be described, by way of example, with reference to the accompanying drawings in which:

20

Figure 1 is the perspective view of an outer rotor motor in one embodiment of the invention;

25

Figure 2 is an exploded view of the outer rotor motor of Figure 1;

Figure 3 is a cross-sectional view of the outer rotor motor in Figure 1 taken along line A-A;

30

Figure 4 is an exploded view of the outer rotor motor cross-section of Figure 3;

Figure 5A is a cross-sectional view of the outer rotor motor in Figure 1 taken along line B-B;

35

Figure 5B is a zoomed in view of part C in Figure 5A;

Figure 5C is a cross-sectional view of the outer rotor motor of Figure 5A labeled with dimensions;

40

Figure 6 is schematic view of a bonded magnet that is used in the outer rotor motor of Figure 1 in one embodiment of the invention; and

Figure 7 is schematic view of a bonded magnet that can be used in the outer rotor motor of Figure 1 in another embodiment of the invention.

45

DETAILED DESCRIPTION OF THE PREFERRED EMBODIMENT

Referring to Figures 1 to 4, there is shown an outer rotor motor 100 in one embodiment of the invention. The main components of the motor 100 include an outer rotor 100A, a stator 100B arranged in a space defined by the outer rotor

50

100A, and an integrated PCB assembly 100C disposed on one side (along the axial direction) of the rotor 100A and stator 100B.

5 The rotor 100A includes a rotor yoke 102, in the form of a hollow cylinder, arranged around a bonded magnet 104, also in the form of a hollow cylinder. The bonded magnet 104 is made with NdFeB. The rotor yoke 102 is electromagnetically conductive. The bonded magnet 104 is fixedly attached to the inner surface of the rotor yoke 102. The bonded magnet 104 has a smaller axial dimension than the rotor yoke 102. The axial end face of the bonded magnet 104 facing the PCB assembly 100C and the axial end face of the rotor yoke 102 facing the PCB assembly 100C are aligned. An end cap 106 is arranged on one side of the bonded magnet 104 and fixedly connected with the rotor yoke 102. The axial end of the end cap 106 facing the bonded magnet 104 includes cutouts for receiving the bonded magnet 104 such that the end cap 106 and the bonded magnet 104 together define a smooth circumferential outer surface. The end cap 106 includes a cylindrical hub 106H with a central through-opening 106O through which the motor shaft 108 passes, and vanes 106V that extend radially outwardly from the cylindrical hub 106H. The outer radial ends of the vanes 106V terminate at an extent corresponding to the outer circumferential surface of the bonded magnet 104. The vanes 106V are distributed evenly angularly about the hub 106H. Between adjacent vanes 106V is respective openings 106VO that allows air to pass. The bonded magnet 104, the yoke 102, and the end cap 106 together define a space in which the stator 100B can be arranged.

25 The rotor 100A also includes an elongated, stepped motor shaft 108 mounted in the central through-opening 106O defined by the hub 106H of the end cap 106. An axial end of the shaft 108 is axially aligned with an axial end face of the end cap 106 facing away from the stator 100B. The shaft 108 is generally cylindrical, with three stepped portions of reducing diameter, extending away from the end cap 106, through the stator 100B and the PCB assembly 100C, and then away from the PCB assembly 100C. The stepped portion with the largest diameter of the shaft 108 has an outer annular groove 108G for receiving a C-clip 110 for assembling the motor 100. The stepped portion with the smallest diameter of the shaft 108 has an outer threaded surface 108T. A mounting sleeve 112 with a central through-opening 112O is arranged at an end of the shaft 108 near the end cap 106. The mounting sleeve 112 includes an annular base 112B of larger outer diameter and another annular support 112S of smaller outer diameter integral with the annular base 112B. The part of the through-opening 112O defined by the annular base 112B defines an interior space for receiving a bearing 114 and a wave spring washer 116 for supporting rotation of the shaft 108. The wave spring washer 116 abuts the axial end face of the interior axial wall of the annular support 112S. The annular support 112S is arranged to be received in an opening 124 defined by the stator 100B. The bonded magnet 104, the rotor yoke 102, the end cap 106, and the shaft 108 are arranged coaxially with respect to the rotation axis R, about which the rotor 100A rotates.

Referring now to Figures 2 to 5B, the stator 100B includes an annular stator yoke 120 defining a central through-opening 124 through which the shaft 108, the mounting sleeve 112, and the support part 130S of the PCB assembly

100C can pass. Radially outwardly extending teeth 122 are arranged around the stator yoke 120. In this embodiment, the stator 100B includes twelve teeth 122 that are evenly angularly spaced apart. Slots are defined between adjacent teeth 122. Each tooth 122 defines a tooth tip 122T with a circumferential extension. The outer circumferential surface of the teeth 122 is spaced apart from the rotor yoke 102 by an annular air gap G1. Windings 126 are wound around the teeth 122. The outer circumferential surface defined by the tips 122T of the teeth 122 is complementary to the inner surface of the rotor yoke 102. For simplicity, the detailed control and excitation scheme of the windings 126 is omitted.

Referring to Figure 5C, in this example, the bonded magnet 104 has a thickness of about 3.00mm and an axial length (Figure 2) of about 30mm. The thickness of the rotor yoke 102 is about 4.50mm. The thickness of the stator yoke 120 is about 3.54mm. The thickness of the tooth 122 is about 20.46mm, including a tooth tip 122T thickness of about 1.50mm.

The integrated PCB assembly 100C of the motor 100 is best illustrated in Figures 2 to 4. The PCB assembly 100C includes a thin, generally planar body 130B holding circuit and electronic components (for clarity, not shown) mounted thereon. The body 130B includes a generally round contour, with four radially outwardly extending mounting parts 130M, and a central through-opening 132. The axial end face of the body 130B facing the stator 100B and rotor 100A is spaced apart from the stator 100B to define an axial gap G2. The mounting parts 130M each defines an opening 130MO, which may be threaded, for receiving a fastener (not shown) to mount the motor 100 to a support structure such as another casing. An integral annular support sleeve 130S projects from the axial end face of the body 130B, towards the rotor 100A and stator 100B. The annular support sleeve 130S is received in the central through-opening 124 of the stator 100B. The through-opening 132 in the body 100B is arranged to receive a bearing 140 for supporting rotation of the shaft 108. The C-clip 110, when mounted in the groove 108B of the shaft 108, abuts the axial end face of the bearing 140. Referring to Figure 3, the air-gap G1, the axial gap G2, and the air flow openings 106VO are in fluid communication to define a cooling air flow path.

Figure 6 shows the bonded magnet 104 used in the outer rotor motor 100 of Figure 1. The bonded magnet 104 has circumferentially alternating North and South poles 104P. In this example, there are 10 poles of generally the same angular extension (e.g., each spans about 36 degrees), extending in parallel to the axial dimension of the magnet 104. The magnetization produced by the poles in this example is a straight magnetization.

Figure 7 shows another bonded magnet 104' that can be used in the outer rotor motor 100 of Figure 1. In this example, the bonded magnet 104' has circumferentially alternating North and South poles 104P', but extending obliquely with respect to the axial dimension of the magnet 104'. The magnetization produced by the poles in this example is a skewed magnetization.

In operation, the windings 126 of the stator 100B receive control signal from the PCB assembly 100C and electromagnetically interact with the bonded magnet 104 of the rotor 100A. Through the electromagnetic interaction between

the poles on the magnet 104 and the stator windings 126, the bonded magnet 104 is driven into rotation. The shaft 108, which connects with the bonded magnet 104 through the end cap 106, and is supported by the bearings 114, 140, is thus driven into rotation for driving a load operably connected to the shaft 108.

5

The motor in the present embodiment is relatively light and compact. It can provide high torque and can operate efficiently, with high power density and torque density. The motor can be manufactured easily and at low cost. The use of bonded magnet allows the magnetic properties of the rotor to be tailored for specific applications. The mounting of the bonded magnet around a rotor yoke facilitates manufacture and assembly, and can provide higher magnetic flux and improved inertial effect. Alternatively, the rotor yoke can be mounted around the bonded magnet to improve flux linkage. The motor end cap, as part of the motor, can provide effective cooling, thereby effectively preventing overheating during operation.

15

For simplicity and clarity, the detailed winding scheme and control of the stator windings are not illustrated. Also, the drawings present the motor schematically and not necessarily in scale. It will be appreciated by persons skilled in the art that numerous variations and modifications may be made to the described embodiments, and that the described embodiments should be considered in all respects as illustrative, not restrictive.

20

For example, the stator may have a different form. The stator may have more than ten teeth or less than ten teeth (but at least two). The teeth need not have identical form and dimension, but can have different width and height. For example, adjacent teeth can be of different width. The separation between adjacent teeth can alter such that the teeth do not distribute evenly angularly. The tips of the teeth can be different thickness. Their radial outer surfaces preferably define a smoothly shaped contour (e.g., annular). The windings wound onto the teeth can be arranged in with one or more groups each under a respective control signal. The number of wires for the windings may be selected for specific application.

25

30

The rotor may have a different form. The position of the rotor yoke and the bonded magnet can be exchanged. The bonded magnet can be of other shape, and may have more than or less than ten poles (at least two, even numbered). The arc segments of the poles may be of different size. The poles may be skewed. The bonded magnet may be arranged around (on the outer surface) of the rotor yoke or vice versa. The end cap may take a different form. The end cap attached to the bonded magnet or the rotor yoke can have no heat dissipation means, or alternative or additional heat dissipation means. For example, the radial vanes can be replaced with fan blades. The end cap may have any number of vanes, blades, etc. The end cap may incorporate a fan. The motor shaft can take different form, with additional or no stepped portion. The motor shaft can take any cross-sectional shape. The axial end of the shaft need not be threaded. The motor shaft can rotate on any types of bearing, such as ball bearing, roller bearing, etc. The motor shaft can be considered as part of the rotor or alternatively as a separate part. The integrated PCB assembly can be considered as part of the stator, or alternatively, as a separate part.

35

40

45

50

The PCB assembly may be shaped differently. The PCB assembly may have more than four or less than four mounting portions. The mounting portions need not be arranged oppositely. The mounting portions can be a hole of any shape, optionally threaded, for receiving a fastener such as screw, nut, bolt, etc. Alternatively, the mounting portions can be a fastener, such as a projection, a latch, etc., arranged to engage with holes on another structure.

The dimensions of the motor may vary. The air gap G1 is preferably less than 1.50mm thick, more preferably less than 1.00mm thick. The thickness of the magnet is preferably between 1.00mm and 8.00mm. The rotor yoke is preferably thicker than the magnet, but in some cases it may be thinner.

The outer rotor motor of the invention can be used in power tools such as drills, drivers, etc., gardening tools such as mowers, chainsaws, blowers, trimmers, etc., and various indoors/outdoors electrical appliances such as fan, ceiling fan, food processor, blender, juicer, vacuum cleaner, dishwashers, washing machines, etc. The outer rotor motor can operate with different power, preferably DC power. In one example, the DC power is provided by one or more battery pack(s) with nominal voltage of 18V, 36V, 48V, 56V, etc.

CLAIMS

1. An outer rotor motor, comprising:
a stator; and
5 a rotor including a bonded magnet arranged around the stator, with an air-gap arranged between the bonded magnet and the stator.
2. The outer rotor motor of claim 1, wherein the bonded magnet is in the form of a hollow cylinder.
- 10 3. The outer rotor motor of claim 2, wherein the bonded magnet has circumferentially alternating poles.
4. The outer rotor motor of claim 3, wherein the poles are of substantially the same angular extension.
- 15 5. The outer rotor motor of any one of claims 1 to 4, wherein the rotor further comprises a rotor yoke arranged around the bonded magnet.
- 20 6. The outer rotor motor of any one of claims 1 to 5, further comprising an integrated PCB assembly arranged on one side of the bonded magnet.
7. The outer rotor motor of claim 6, wherein the integrated PCB assembly includes mounting portions for mounting the outer rotor motor to a support structure.
- 25 8. The outer rotor motor of claim 6 or 7, wherein an axial gap is defined between the bonded magnet and the integrated PCB assembly.
- 30 9. The outer rotor motor of any one of claims 6 to 8, wherein the rotor further comprises an end cap with vanes, arranged on another side of the bonded magnet opposite the integrated PCB assembly.
10. The outer rotor motor of claim 9, wherein the vanes extend radially and are evenly angularly spaced apart.
- 35 11. The outer rotor motor of claim 9 or 10, wherein an air flow opening is arranged between respective adjacent vanes.
- 40 12. The outer rotor motor of claim 11, wherein the air-gap, the axial gap, and the air flow openings are in fluid communication to define a cooling air flow path.
13. The outer rotor motor of any one of claims 9 to 12, wherein the rotor further comprises a shaft operably coupled with bonded magnet for rotation, wherein the shaft extends through the end cap, the bonded magnet, the stator, and the PCB assembly.
- 45 14. The outer rotor motor of any one of claims 9 to 13, wherein the outer rotor motor is a DC brushless motor.

15. A rotor for an outer rotor motor, comprising:
a bonded magnet configured to be arranged around a stator and spaced apart
from the stator, with an air-gap arranged between the bonded magnet and
the stator.
- 5 16. The rotor of claim 15, wherein the bonded magnet is in the form of a hollow
cylinder.
- 10 17. The rotor of claim 16, wherein the bonded magnet has circumferentially
alternating poles.
18. The rotor of claim 17, wherein the poles are of substantially the same angular
extension.
- 15 19. The rotor of any one of claims 15 to 18, further comprising a rotor yoke
arranged around the bonded magnet.
20. The rotor of any one of claims 15 to 19, further comprising an end cap with
vanes, arranged on one side of the bonded magnet.
- 20 21. The rotor of claim 20, wherein the vanes extend radially and are evenly
angularly spaced apart.
- 25 22. The rotor of claim 21, wherein an air flow opening is arranged between
respective adjacent vanes.
23. An outer rotor motor comprising the rotor of any one of claims 15 to 22.
- 30 24. An electric appliance or tool comprising the outer rotor motor of any one of
claims 1 to 14 and 23.

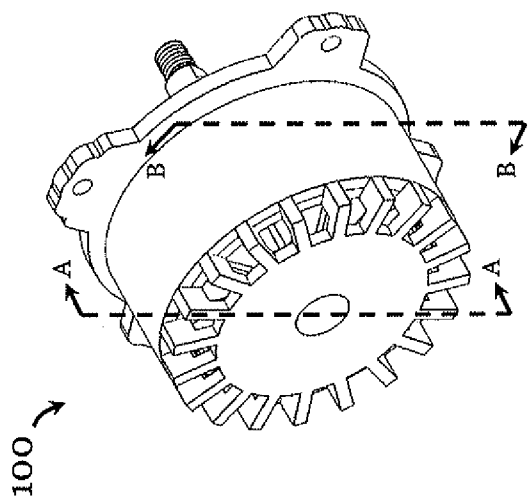

Figure 1

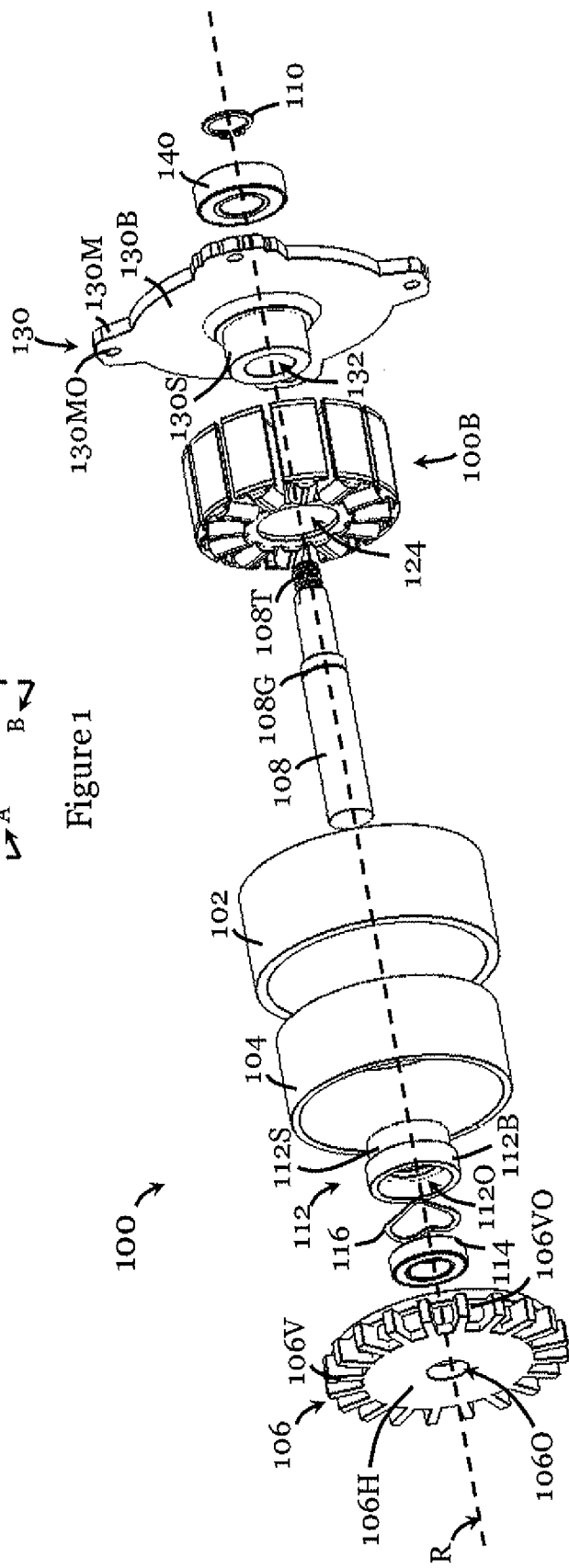

Figure 2

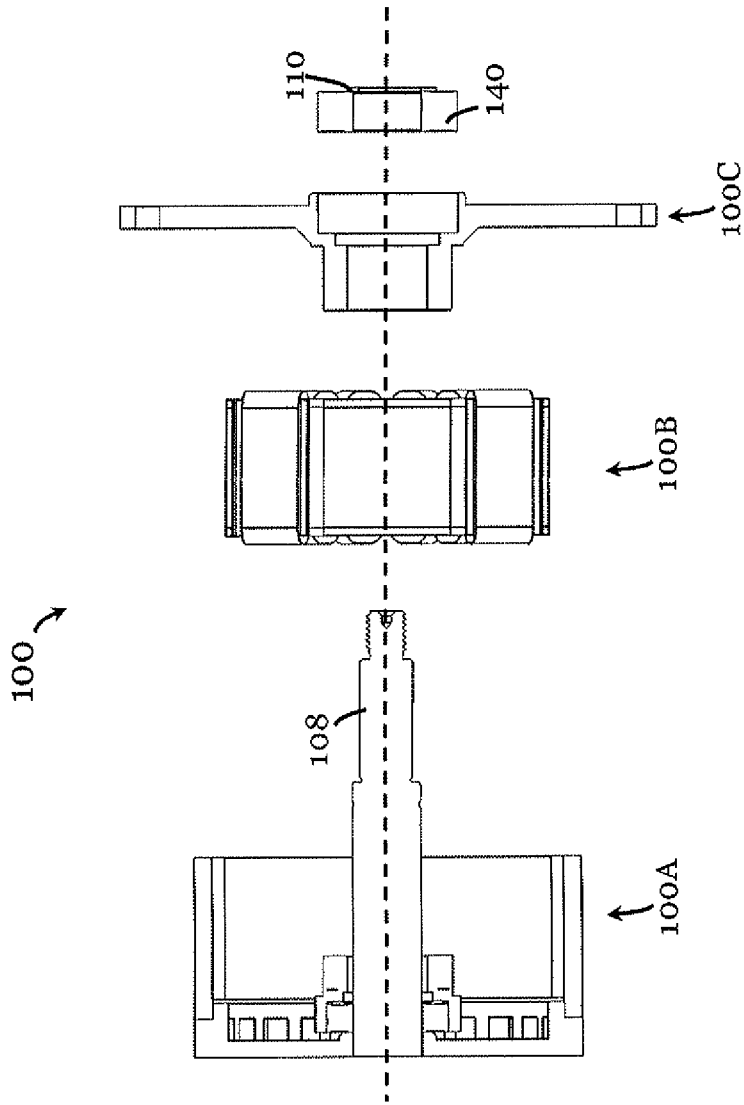

Figure 4

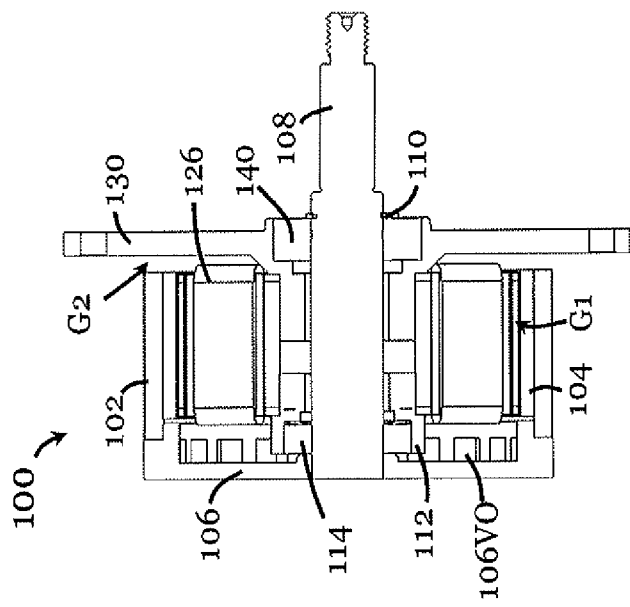

Figure 3

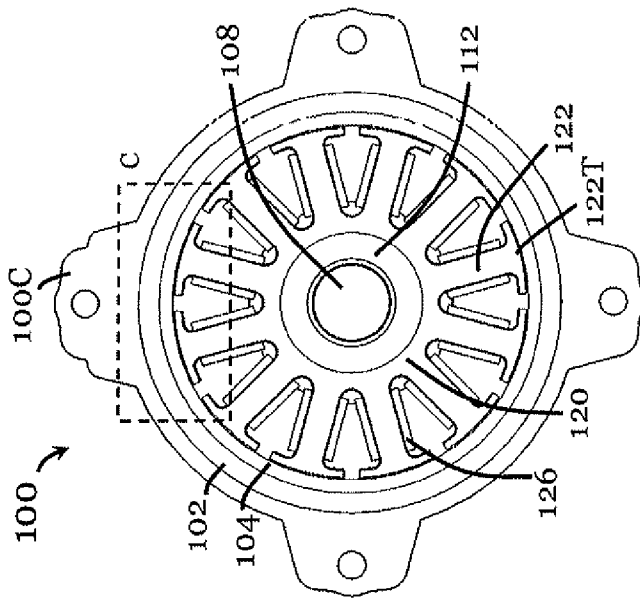

Figure 5A

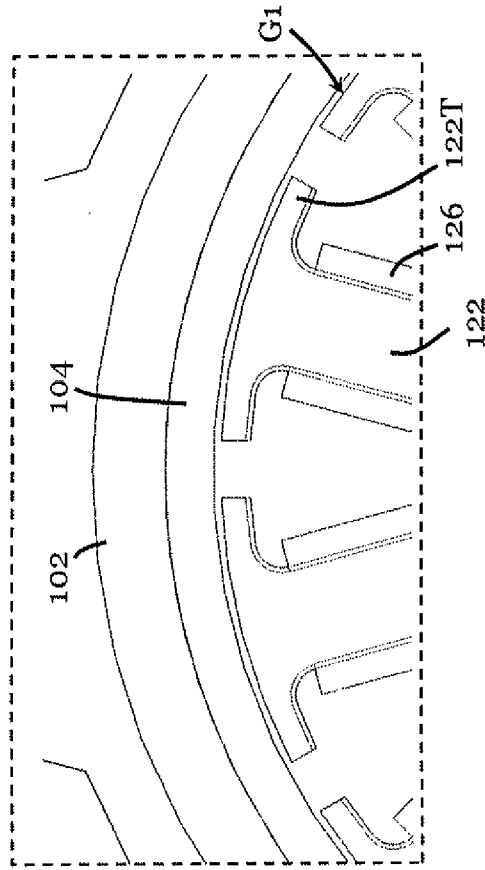

Figure 5B

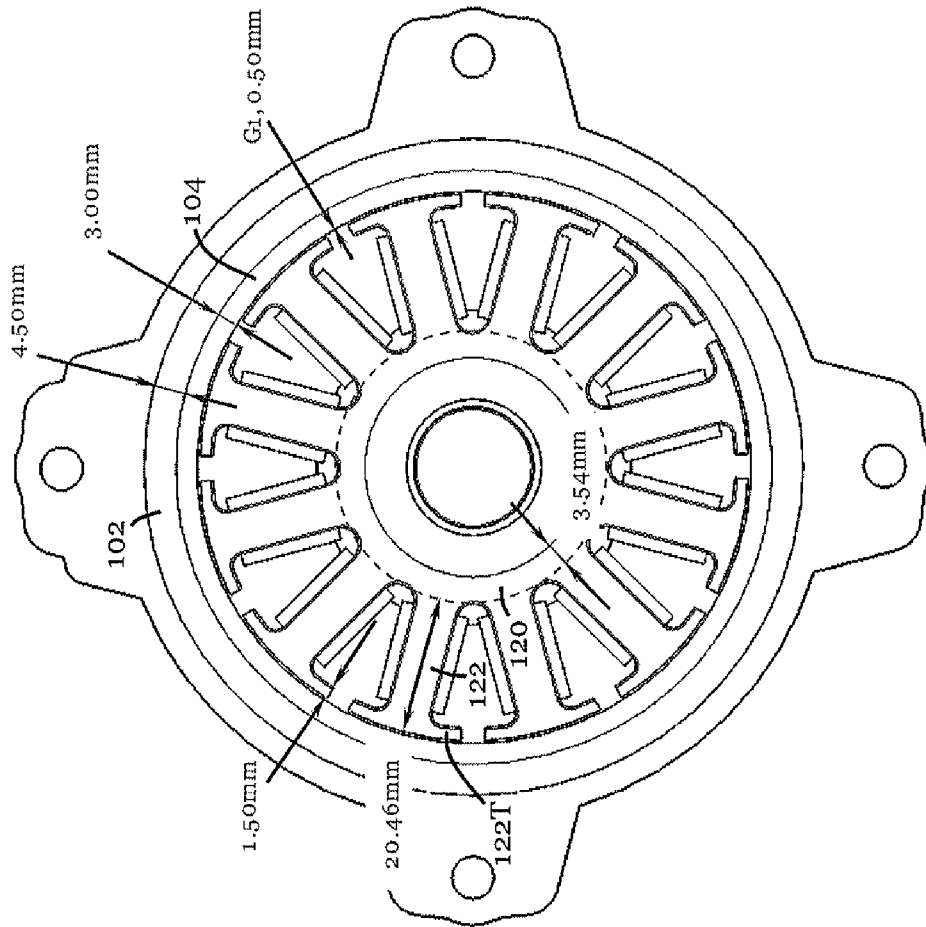

Figure 5C

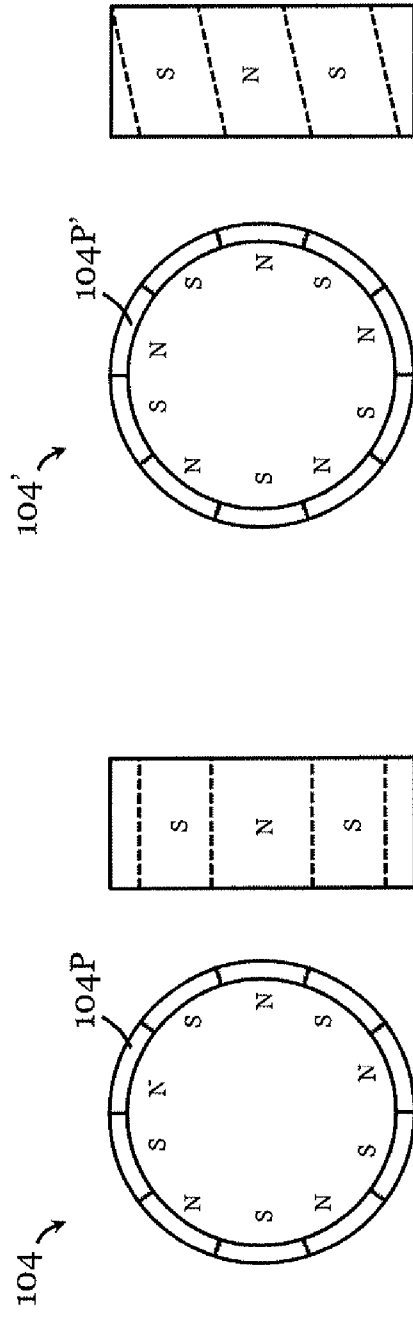

Figure 7

Figure 6

INTERNATIONAL SEARCH REPORT

International application No.

PCT/CN2018/076826

A. CLASSIFICATION OF SUBJECT MATTER		
H02K 29/00(2006.01)i		
According to International Patent Classification (IPC) or to both national classification and IPC		
B. FIELDS SEARCHED		
Minimum documentation searched (classification system followed by classification symbols)		
H02K		
Documentation searched other than minimum documentation to the extent that such documents are included in the fields searched		
Electronic data base consulted during the international search (name of data base and, where practicable, search terms used)		
CNABS;CNKI;DWPI;SIPOABS:outer, rotor, motor, bond+, magnet, gap, NdFeB, tile, PCB		
C. DOCUMENTS CONSIDERED TO BE RELEVANT		
Category*	Citation of document, with indication, where appropriate, of the relevant passages	Relevant to claim No.
X	CN 201994814 U (SHENZHEN CITY MENGLONG MOTORS CO LTD) 28 September 2011 (2011-09-28) see description, paragraphs 0005-0012 and figures 1-3	1-24
X	CN 105932823 A (ZHU, MUSONG) 07 September 2016 (2016-09-07) see description, paragraphs 0010-0013 and figure 1	1-24
X	US 4398134 A (PAPST MOTOREN KG) 09 August 1983 (1983-08-09) see description, column 3, line 1- column 4, line 52 and figures 1-2	1-24
<input type="checkbox"/> Further documents are listed in the continuation of Box C. <input checked="" type="checkbox"/> See patent family annex.		
* Special categories of cited documents: "A" document defining the general state of the art which is not considered to be of particular relevance "E" earlier application or patent but published on or after the international filing date "L" document which may throw doubts on priority claim(s) or which is cited to establish the publication date of another citation or other special reason (as specified) "O" document referring to an oral disclosure, use, exhibition or other means "P" document published prior to the international filing date but later than the priority date claimed "T" later document published after the international filing date or priority date and not in conflict with the application but cited to understand the principle or theory underlying the invention "X" document of particular relevance; the claimed invention cannot be considered novel or cannot be considered to involve an inventive step when the document is taken alone "Y" document of particular relevance; the claimed invention cannot be considered to involve an inventive step when the document is combined with one or more other such documents, such combination being obvious to a person skilled in the art "&" document member of the same patent family		
Date of the actual completion of the international search		Date of mailing of the international search report
29 October 2018		06 November 2018
Name and mailing address of the ISA/CN		Authorized officer
STATE INTELLECTUAL PROPERTY OFFICE OF THE P.R.CHINA 6, Xitucheng Rd., Jimen Bridge, Haidian District, Beijing 100088 China		WANG, Lu
Facsimile No. (86-10)62019451		Telephone No. 86-10-62411952

INTERNATIONAL SEARCH REPORT
Information on patent family members

International application No.

PCT/CN2018/076826

Patent document cited in search report			Publication date (day/month/year)	Patent family member(s)			Publication date (day/month/year)
CN	201994814	U	28 September 2011	None			
CN	105932823	A	07 September 2016	CN	105932823	B	26 January 2018
US	4398134	A	09 August 1983	JP	H0456542	B2	08 September 1992
				HK	6085	A	25 January 1985
				GB	2052883	B	04 April 1984
				GB	2052883	A	28 January 1981
				FR	2457035	B2	26 October 1984
				DE	2919581	C2	07 July 1988
				JP	S55153268	A	29 November 1980
				DE	2919581	A1	27 November 1980
				SG	32187	G	13 November 1987
				FR	2457035	A2	12 December 1980