

Feb. 4, 1930.

E. TRAUB

1,745,516

MULTIPLE ELECTRIC SWITCH

Filed March 29, 1927

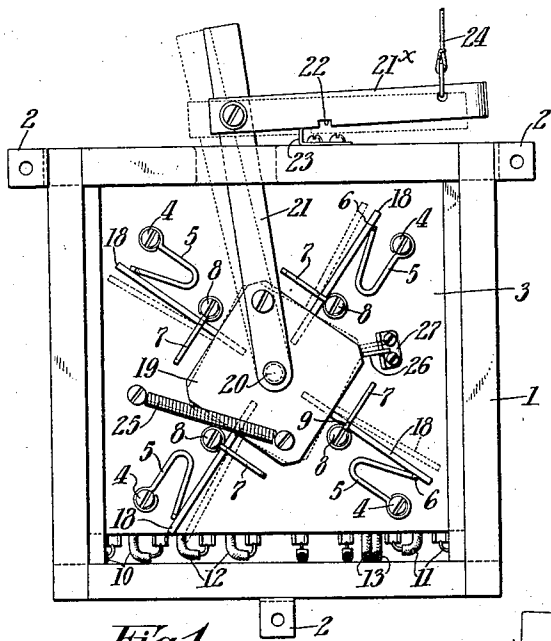

Fig. 1.

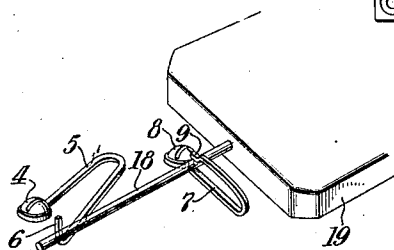

Fig. 4.

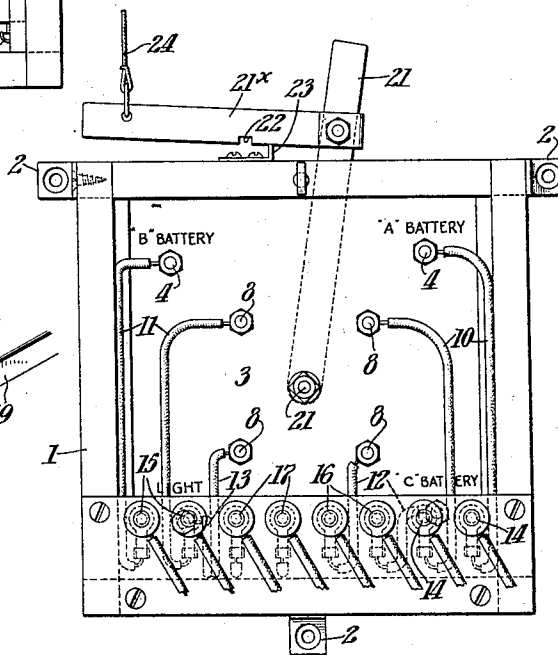

Fig. 2.

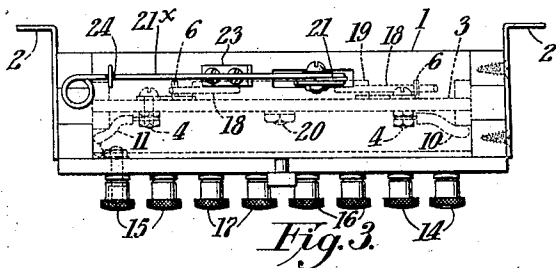

Fig. 3.

Witnesses:
Joseph Peina
Adrian DeMan.

384

William P. Stewart
 Attorney

UNITED STATES PATENT OFFICE

EMIL TRAUB, OF NEWARK, NEW JERSEY

MULTIPLE ELECTRIC SWITCH

Application filed March 29, 1927. Serial No. 179,302.

This invention relates to improvements in electric-circuit controlling devices and more especially to devices of this character particularly adapted to simultaneously control a plurality of electric-circuits. While the present improvement has a general application in this art, it has been particularly designed for use with radio receiving outfits commonly employing a plurality of separate electric-circuits.

The primary object of the present invention is to provide an improved electric-switch for multiple electric circuits such as are, for instance, employed in radio outfits, whereby all of the circuits will be automatically closed simultaneously upon the release of a latch which is preferably tripped by any suitable time operated device, although it is to be understood that the invention is not limited to this use either in its entirety or as to its details of construction.

In a preferred embodiment of the invention, a plurality of pairs of spaced and specially designed contact-members are fixed upon an insulating support, being disposed about a common center constituting the pivotal axis of a plurality of current-transmitting bridges for the pairs of contact-members. The bridges are yieldingly urged by a spring to simultaneously engage both members of each pair of contact members, said bridges in switch-open position being disengaged from both members of each pair of fixed contacts and adapted to be held in switch-open position against the action of said spring by a single latch capable of being readily tripped upon release of the latch-lever either manually or preferably by a time operated device. The engagement between the spaced contact members and their respective bridges is not only yielding in character by virtue of the spring urging the engagement thereof, but also by reason of a yielding construction of the contact-members themselves, thereby insuring a firm current-transmitting contact whenever the latch is released.

In the accompanying drawings, Fig. 1 is an elevation of the improved switch viewed from one side thereof and Fig. 2 is an eleva-

tion of the opposite side of the switch with its cover-plate removed. Fig. 3 is a top-plan view of the device and Fig. 4 is a detail perspective view of a pair of contact-members and the bridge therefor.

Referring to the drawings, the switch is encased in a frame 1 capable of being secured upon, for instance, a radio receiving outfit case (not shown) by the provision upon said frame of apertured ears, as 2. Suitably fixed within said frame 1 is an insulating supporting plate 3 which may be of any material suitable for the purpose. Fixed upon the plate 3, by means of binding posts, as 4, are a plurality of contact-members, as 5, each comprising a substantially U-shaped element of some slightly resilient and electric-current transmitting material. One end of each member 5 is coiled to embrace a binding post 4, while its opposite end 6 (see Fig. 4) is bent at right angles to the plane of the legs of the U-shaped member, i. e., to the plane of the plate 3 against which both legs of said member are disposed.

Spaced from the members 5 are a plurality of contact-members 7 also of substantial U-shape but each having its legs disposed in a plane transversely of the plane of the legs of members 5. The members 7 are each fixed upon a binding post 8 on the supporting plate 3 by coiling one end thereof about said post, while the free ends 9 of said members 7 are shouldered for a purpose later described, it being understood however that the free ends of the members 7 are capable of slightly yielding in a plane perpendicular to the supporting plate 3, while the free ends of the members 5 are capable of slightly yielding in a plane parallel to the plate 3.

The contact-members 5 and 7 are arranged in pairs, whereby as particularly illustrated in Fig. 2 the binding posts 4 and 8 of a pair of contact-members may be connected by leads, as 10, with the terminals of a radio A-battery; another pair of posts 4 and 8 with a radio B-battery by leads, as 11; still another pair with a radio C-battery by leads as 12 and the last pair of posts 4 and 8 by leads, as 13, with an electric-lamp circuit. In order to facilitate the making of the con-

nections when furnishing the switch complete for commercial usage, it is preferred to connect several of the current leads described to suitable binding posts upon the frame 1 and to that end the leads 10 are shown as connected to the posts 14; the leads 11 to the posts 15 and the leads 12 to the posts 16, the light circuit being preferably directly connected with the posts 4 and 8. Additional posts 17 may however be also provided for the light circuit and for radio antennæ connections as may be preferred.

The pairs of contact-members 5 and 7 are symmetrically arranged with respect to a common center constituting the pivotal axis of a plurality of current-transmitting bridges, as 18, each adapted in circuit closed position to firmly engage the free ends of a pair of members 5 and 7, as illustrated particularly in Fig. 4 of the drawings. When the bridges 18 swing into circuit closing position, the free ends thereof engage the upstanding ends 6 of the members 5 while the inner ends of the bridges 18 engage the shouldered portion 9 of the contact-members 7, said shouldered portions 9 affording a clearance rearward thereof whereby the bridges 18 when retracted are entirely out of engagement with the contact-member 7 as well as with the member 5. The bridges 18 comprise rods of some suitable electric-conductor material, which rods are fixedly secured in an oscillatory carrier-block 19 of insulating material sustained by a pivot-bolt 20 upon the supporting plate 3. Secured upon the block 19 is the supporting arm 21 of a latch-lever 21* pivotally supported upon said arm 21 and provided with a notch 22 adapted to be latched to a keeper 23 secured upon the frame 1. The free end of the arm 21* may be connected by means of a cord 24 with a suitable time operated device (not shown).

The operation of latching the arm 21* upon the keeper 23 must be effected against the action of a spring 25, one end of which is secured to the supporting plate 3 and the other end to the carrier-block 19 at the side of the center of said block to normally urge the bridges 18 into circuit-closing engagement with the pairs of contact-members 5 and 7. Projecting from the carrier-block 19 is a stop-finger 26 operating in conjunction with a slotted stop-plate 27 to limit the oscillating movements of the block 19, to thereby prevent damaging the contact elements by careless manipulation of the switch.

The operation of the present improved switch will be self-evident from the foregoing description. Should it for instance be desired to render active the several circuits of a radio receiving outfit at a predetermined time in order to insure receiving a scheduled program, it is only necessary to connect the arm 21*, latched to the keeper 23 in order to hold the circuits open, with any time operated de-

vice such as the winding stem of an alarm-clock. At the appointed time the arm 21* will be released and all of the circuits will be simultaneously closed, thereby rendering them active in the performance of their functions.

Having thus set forth the nature of the invention, what I claim herein is:—

1. An electric-switch comprising an insulating support, a pair of spaced contact-members of an electric-circuit sustained by said support, and a current-transmitting bridge shiftable to simultaneously engage both of said contact-members, one of said contact-members being disposed to yield in the direction of shifting movement of the bridge-member and the other contact-member to yield in a direction transverse thereto.

2. An electric-switch comprising an insulating support, a plurality of pairs of spaced contact-members of a plurality of electric-circuits sustained upon said support, an electric-current transmitting bridge for each pair of contact-members adapted to simultaneously engage and disengage both contact-members of each pair thereof, a spring yieldingly urging the several bridge members and their respective pairs of contact-members into current-transmitting engagement, one of the contact-members of each pair being adapted to yield in the direction of engagement of a bridge therewith, and means for latching the contact-members and bridges in switch-open position.

3. An electric-switch comprising an insulating support, a plurality of spaced pairs of contact-members of a plurality of electric-circuits fixed upon said support about a common center, the contact-members of each pair being disposed to yield in transverse directions, an electric-current transmitting bridge for each pair of contact-members pivotally sustained upon said support to engage and disengage both of the contact-members of a pair, a spring yieldingly urging said bridges about their pivotal support in one direction, and a latch for restraining any movement of said bridges under the action of said spring.

In testimony whereof, I have signed my name to this specification.

EMIL TRAUB.