

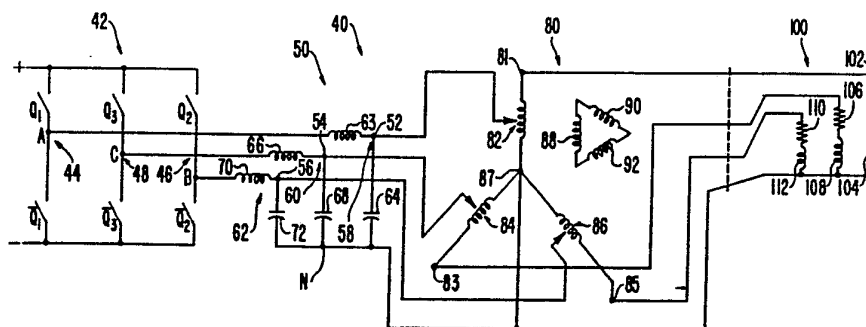

INTERNATIONAL APPLICATION PUBLISHED UNDER THE PATENT COOPERATION TREATY (PCT)

<p>(51) International Patent Classification 5 : H02M 7/5387</p>	<p>A1</p>	<p>(11) International Publication Number: WO 90/06014</p> <p>(43) International Publication Date: 31 May 1990 (31.05.90)</p>
<p>(21) International Application Number: PCT/US89/04441</p> <p>(22) International Filing Date: 10 October 1989 (10.10.89)</p> <p>(30) Priority data: 272,061 16 November 1988 (16.11.88) US</p> <p>(71) Applicant: SUNDSTRAND CORPORATION [US/US]; 4949 Harrison Avenue, P.O. Box 7003, Rockford, IL 61125 (US).</p> <p>(72) Inventors: SHEKHAWAT, Sampat, S. ; 3663 Flambeau Drive, Rockford, IL 61111 (US). SHAH, Mahesh, J. ; 1965 Rothchild Lane, Rockford, IL 61107 (US). DHY-ANCHAND, John, J. ; 2721 Pelham Road, Rockford, IL 61107 (US).</p> <p>(74) Agent: LANYI, William, D.; 4949 Harrison Avenue, P.O. Box 7003, Rockford, IL 61125 (US).</p>		<p>(81) Designated States: AT (European patent), BE (European patent), CH (European patent), DE (European patent), FR (European patent), GB (European patent), IT (European patent), JP, LU (European patent), NL (European patent), SE (European patent).</p> <p>Published <i>With international search report.</i></p>

(54) Title: THREE PHASE INVERTER POWER SUPPLY WITH BALANCING TRANSFORMER



(57) Abstract

A three phase inverter (40) is disclosed for use with loads (100) which are unbalanced. A transformer (80) having primary windings (82), (84) and (86) which are respectively connected to phase outputs (52, 54 and 56) has a secondary having individual windings (88, 90 and 92) connected in a delta configuration which minimizes the flow of unbalanced current in the unbalanced load. A second embodiment utilizes a transformer in an interconnected configuration. A neutral connecting the conductive switches to the load is unnecessary with the invention.

FOR THE PURPOSES OF INFORMATION ONLY

Codes used to identify States party to the PCT on the front pages of pamphlets publishing international applications under the PCT.

AT	Austria	ES	Spain	MG	Madagascar
AU	Australia	FI	Finland	ML	Mali
BB	Barbados	FR	France	MR	Mauritania
BE	Belgium	GA	Gabon	MW	Malawi
BF	Burkina Fasso	GB	United Kingdom	NL	Netherlands
BG	Bulgaria	HU	Hungary	NO	Norway
BJ	Benin	IT	Italy	RO	Romania
BR	Brazil	JP	Japan	SD	Sudan
CA	Canada	KP	Democratic People's Republic of Korea	SE	Sweden
CF	Central African Republic	KR	Republic of Korea	SN	Senegal
CG	Congo	LI	Liechtenstein	SU	Soviet Union
CH	Switzerland	LK	Sri Lanka	TD	Chad
CM	Cameroon	LU	Luxembourg	TG	Togo
DE	Germany, Federal Republic of	MC	Monaco	US	United States of America
DK	Denmark				

Three Phase Inverter Power Supply
With Balancing Transformer

Technical Field

5 The present invention relates to three phase
inverter power supplies with unbalanced loads having
reduced weight. More particularly, the present
invention relates to power supplies of the foregoing
type which do not have a neutral line running from the
10 power supply to the load.

Background Art

15 Fig. 1 illustrates a three phase auto
transformer 10 having first, second and third primary
windings 12, 14 and 16 which are respectively
magnetically coupled to secondary windings 18, 20 and
22. The secondary windings 18, 20 and 22 are in a
delta connected tertiary which is idle under normal
balanced operation but contains current flow when a
fault or an unbalanced load situation exists in
20 electrical loads (not illustrated) connected to the
phase outputs 24, 26 and 28. Phase inputs are applied
to terminals 30, 32, and 34.

25 Figs. 2A and B illustrate respectively a three
phase auto transformer and a zig-zag transformer with
windings 13, 15 and 17 connected to phase inputs and
outputs 30, 32 and 34 and ground which is known as an
interconnected star grounding transformer. In Fig. 2A
each of the windings 13, 15 and 17 has a first part 19
wound in a first direction and a second part 21 wound
30 in the opposite direction. In Fig. 2B, each of the

windings 13, 15 and 17 has a first part 19 and a second part 21 wound in the same direction. In Figs. 2A and B, the windings 13, 15 and 17 function to divide the neutral current into three equal parts when the transformer is connected to an unbalanced load (not illustrated).

United States Patent 4,617,622 discloses a three phase inverter which has three pairs of switches connected between reference points of a DC potential. The switches are switched to produce a three phase AC output. The three phase output is filtered. The filtered output is connected to a neutral forming transformer.

A power supply has been developed by Westinghouse Electric Corporation having a switching matrix which switches a DC potential coupled to the switching matrix to create a staircase waveform at a desired fundamental frequency to produce three phase AC. With reference to Fig. 3 of the present invention, the prior art Westinghouse topology has a switching matrix containing switches Q_1 , $\overline{Q_1}$, Q_2 , $\overline{Q_2}$, Q_3 and $\overline{Q_3}$ which are switched to provide a three-phase output which is connected to a filter and a neutral forming transformer. For an unbalanced load, current flows from one of the switches Q_1 , Q_2 and Q_3 which is conductive through the load, the neutral, and back to the negative terminal of the DC source through two of the switches $\overline{Q_1}$, $\overline{Q_2}$ and $\overline{Q_3}$ which are not connected to a conductive switch. This power supply does not utilize a fourth wire to return current flowing through the neutral to the DC source.

United States Patent 3,775,663 discloses that a problem has existed regarding inverters with a neutral

terminal in maintaining the neutral terminal at correct potential when loads are unbalanced. The '663 patent further discloses that inverters with three output terminals have used a polyphase output transformer connected, for example, delta on the inverter side and wye on the load side. This produces a neutral transformer terminal which is undisturbed by unbalanced loads. The '663 patent further discloses that the pulse width modulation of each phase of an inverter to produce three phase output current. Each inverter phase consists of a pair of switches connected between two reference potentials which are alternatively pulse width modulated such that each switch is closed to conduct current from one of the reference potentials through a phase output which is filtered to eliminate higher frequency components than the fundamental desired phase output. Furthermore, the configuration of the inverter requires that the potential which is to be applied to the load must be switched completely by the switches of the inverter. If a high potential is required for the load, it is necessary for the switches to switch this high potential which can cause damage or failure.

United States Patent 4,564,895 which is assigned to the assignee of the present invention discloses a bidirectional switch which connects an inverter to the neutral.

United States patent application Serial No. 128,444, filed on December 3, 1987, which is assigned to the assignee of the present invention, discloses a DC to AC inverter with neutral in which the neutral is formed by a filter which functions to shunt

high frequency harmonics to the neutral of the inverter and an envelope defined by the fundamental frequency being applied to a three phase load with neutral. The inverter has first, second and third switching circuits each having a series circuit having first and second switches with at least one of the first switches and at least one of the second switches being in the on state during operation of the inverter in driving an unbalanced load to permit current to flow from the LC circuit to the unbalanced load and from the unbalanced load back to the LC circuit without a fourth wire.

In airframes it has been the practice to run three phases and a fourth wire which is a neutral from the generator to the load. The fourth wire adds considerable weight as a consequence of a large diameter necessary to permit the flow of substantial neutral current when the three phase load is substantially unbalanced. This fourth wire represents a weight penalty.

Disclosure of Invention

The present invention provides a multiple phase inverter power supply with neutral for connection to unbalanced loads having reduced weight and which eliminates a neutral running between the inverter and the load. Furthermore, the invention reduces the voltage switched across the inverter switches when a transformer is used which has a stepped up output while achieving the weight savings of elimination of the neutral between the inverter switches and the load which is of particular importance in airframes. Each

of the phase outputs from the power supply are connected to a filter which removes ripple frequency components higher than the fundamental. The filter forms a neutral for conducting unbalanced current flow in a multiple phase unbalanced load and eliminates the neutral running between the inverter and load. The respective phase outputs from the filter are connected to a transformer having its primary windings in a wye configuration. A secondary delta winding functions as a balancing winding to minimize the flow of unbalanced current in a three phase unbalanced load respectively having phases connected to the different primary windings. Alternatively, the transformer may be an interconnected star grounding transformer.

A multiple phase inverter with a neutral in accordance with the invention includes a plurality of pairs of phase switches, each pair of phase switches being connected in series between first and second reference potentials, each switch being switched between conductive and non-conductive states; a plurality of outputs each respectively coupled at a junction between a different pair of the plurality of pairs of switches; a controller for causing each switch of a pair of switches which is connected to one of the first and second reference potentials to be conductive for an interval and for causing at least one other switch of one of the other pairs of switches which is connected to another of the first and second reference potentials to also be conductive during the interval to provide a path for current between the switches without a neutral connecting the conductive switches to the load; a filter having a plurality of inputs coupled

respectively to a different one of the outputs and forming the neutral, the filter shunting frequency components above a fundamental frequency determined by a switching rate of the pairs of switches to the neutral and respectively providing a plurality of different phase outputs at the fundamental frequency; a multiple phase transformer having a plurality of windings coupled in a wye configuration with a first terminal of a plurality of inputs of the transformer respectively coupled to a different one of the plurality of outputs and a second terminal of the windings coupled to the neutral and a phase output coupled to each of the windings, the transformer having a secondary with a plurality of windings connected in a delta configuration; and the phase outputs of the transformer each respectively being for connection to a separate phase of an unbalanced multiple phase load. The conductive interval of each switch is pulse width modulated during a cycle of current with a duty cycle proportional to a desired magnitude of current at any point in time during a cycle of current on a different one of the phase outputs. The transformer may be an auto transformer which steps up potential applied to the windings from the inverter to the load.

A multiple phase inverter with a neutral in accordance with the invention includes a plurality of pairs of phase switches, each pair of phase switches being connected in series between first and second reference potentials, each switch being switched between conductive and non-conductive states; a plurality of outputs each respectively coupled at a junction between a different pair of the plurality of

pairs of switches; a controller for causing a
conductive interval of each switch of a pair of
switches which is connected to one of the first and
second reference potentials to be conductive for an
5 interval and for causing at least one other switch of
one of the other pairs of switches which is connected
to the other of the first and second reference
potentials to also be conductive during the interval to
provide a path for current between the switches without
10 a neutral connecting the conductive switches to the
load; a filter having a plurality of inputs coupled
respectively to a different one of the outputs and
forming the neutral, the filter shunting frequency
components above a fundamental frequency determined by
15 a switching rate of the pairs of switches to the
neutral and respectively providing a plurality of
different phase outputs at the fundamental frequency; a
multiple phase transformer having a plurality of
windings coupled in an interconnected star
20 configuration with a first terminal of a plurality of
inputs respectively coupled to a different one of the
plurality of phase outputs and a second terminal of the
windings coupled to the neutral and a phase output
coupled to each of the windings and the phase outputs
25 of the transformer each respectively being for
connection to a separate phase of an unbalanced
multiple phase load. The conductive interval of each
switch is pulse width modulated during a cycle of
current with a duty cycle proportional to a desired
30 magnitude of current at any point in time during a
cycle of current on a different one of the phase
outputs. The transformer may be an auto transformer

which steps up a potential applied to the windings from the inverter to the load.

Brief Description of Drawings

5 Fig. 1 illustrates a first type of prior art transformer for use in unbalanced three phase power supplies.

Figs. 2A and B illustrate prior art transformers for use in unbalanced three phase power supplies.

10 Fig. 3 illustrates an embodiment of the present invention.

Fig. 4 illustrates a second embodiment of the present invention.

Best Mode for Carrying Out the Invention

15 Fig. 3 illustrates a first embodiment 40 of the present invention. The embodiment provides a multiple phase inverter power supply for connection to unbalanced loads with a transformer having a wye connected primary and a delta connected secondary for minimizing the effect of unbalanced current flow in the multiple phase unbalanced load which eliminates a neutral between the inverter switches and the load which is an important weight savings for power supplies in airframes. Furthermore, when a step up transformer is used between the inverter and load, the potential 20 switched across switches of the inverter is reduced which is beneficial when a high potential is to be applied to the load. A three phase inverter 42 provides switched DC potentials of either positive or negative polarity respectively at the outputs A, B and 25 C which are phase displaced 120° from each other. 30

Switches Q_1 and $\overline{Q_1}$ are switched to produce the phase A output. Switches Q_2 and $\overline{Q_2}$ are switched to produce the phase B output. Switches Q_3 and $\overline{Q_3}$ are switched to produce the phase C output. Each of the switches Q_1 , $\overline{Q_1}$, Q_2 , $\overline{Q_2}$, Q_3 and $\overline{Q_3}$ has a conductive interval which conducts current to its phase output. The conductive interval is pulse width modulated in accordance with conventional inverter operation to produce output pulses having a duty cycle directly proportional to the magnitude of a sine wave at any particular time during a cycle of current produced by the phase. As a consequence of elimination of the neutral between the inverter switches and the load, a return path for current must be provided back to the inverter for current flowing from any one of the outputs A, B or C by appropriate control of the switches as follows. When any one of the switches Q_1 , Q_2 and Q_3 of the pairs 44-48 is conductive, at least one of the switches $\overline{Q_1}$, $\overline{Q_2}$ and $\overline{Q_3}$ of at least one of the other pairs is conductive to permit current to flow from one of the reference potentials (+) through one of switches connected to the reference potential from one of the outputs A, B or C to the three phase load and back to at least another one of the outputs A, B or C through at least one of the switches which is coupled to the other of the reference potentials (-). A controller for switching the switches in accordance with the foregoing sequence is not described herein as it is conventional practice to control the time of switching and duty cycles of switches in inverters. However, as is understood by those skilled in the art, the controller is based upon conventional designs for

switching switches in inverters which are not part of the present invention. It should be understood that each of the pairs of switches 44, 46 and 48 may be implemented in any switching device having conductive and non-conductive states which are changed in response to switching signals. The pulse width modulated current pulses produced by the respective phase outputs A, B and C are applied to a filter 50. The filter 50 functions to pass the fundamental frequency to phase outputs 52, 54 and 56 and shunt higher frequency ripple current to the neutral N. The filter 50 has three LC filters 58, 60 and 62. The LC filter 58 is comprised of inductor 62 and capacitor 64. The filter 60 is comprised of inductor 66 and capacitor 68. The filter 62 is comprised of inductor 70 and capacitor 72. Each of the filters 58, 60 and 62 function to shunt higher harmonics to the neutral N and to pass the fundamental frequency respectively at the phase outputs 52, 54 and 56.

The phase outputs 52, 54 and 56 are applied to auto transformer 80. The phase A output 52 is applied to winding 82. The phase C output 54 is applied to winding 84. The phase B output 56 is applied to winding 86. The junction 87 of the windings 82, 84 and 86 are connected to the neutral N. As illustrated, the transformer 80 is a step up transformer with the inputs 52, 54 and 56 being connected to the windings 82, 84 and 86 at a point for providing a desired amount of stepping up the voltage on the outputs 81, 83 and 85. For loads which require high potentials, the use of a step up transformer is

advantageous in lessening stress on the switches of the inverter 42. However, it should be understood that the invention is not limited to use of a step up transformer. The secondary of the transformer consists
5 of a delta connection of secondary windings 88, 90 and 92 which are respectively magnetically coupled to windings 82, 84 and 86. The secondary delta windings 88, 90 and 92 function to minimize the flow of unbalanced current in unbalanced three phase load 100.
10 It should be understood that the unbalanced three phase load 100 may be any three phase unbalanced load with the illustrated load being only suggestive of possible types of unbalanced loads which may be utilized with the present invention. As illustrated, the phase A
15 portion of the three phase load 100 consists of resistor 102 connected in series with inductor 104 which is connected to the neutral N. The phase C portion of the unbalance load 100 consists of resistor 106 which is connected in series with
20 inductor 108 which is connected to the neutral N. The phase B portion of the unbalanced load 100 consists of resistor 110 which is connected in series with inductor 112 which is connected to the neutral N.

Fig. 4 illustrates an alternative embodiment which
25 differs from Fig. 3 in the type of transformer that is used. Like reference numerals identify like parts. Transformer 120 is configured as a step up interconnected star grounding transformer. The transformer minimizes unbalanced current flow. The
30 transformer 120 may be a single core with three parallel legs which are interconnected with a magnetically permeable material or three separate

magnetically linked transformers as illustrated. The amount that the outputs 81, 83 and 85 are stepped up is determined by the DC potential of the inverter and the desired potential to be applied to the three phase load.

5

While the invention has been described in terms of its preferred embodiment, it should be understood that numerous modifications may be made thereto without departing from the spirit and scope of the invention as defined in the appended claims. It is intended that all such modifications fall within the scope of the appended claims.

10

Claims

1. A multiple phase inverter with a neutral comprising:

5 a plurality of pairs of phase switches, each pair of phase switches being connected in series between first and second reference potentials, each switch being switched between conductive and non-conductive states;

10 a plurality of outputs each respectively coupled at a junction between a different pair of the plurality of pairs of switches;

15 means for causing each switch of a pair of switches which is coupled to one of the first and second reference potentials to be conductive for an interval and for causing at least one other switch of one of the other pairs of switches which is coupled to the other of the first and second reference potentials to also be conductive during the interval to provide a path for current between the switches without a neutral
20 connecting the conductive switches to the load;

25 a filter having a plurality of inputs coupled respectively to a different one of the outputs and forming the neutral, the filter shunting frequency components above a fundamental frequency determined by a switching rate of the pairs of switches to the neutral and providing a plurality of different phase
30 outputs at the fundamental frequency;

a multiple phase transformer having a plurality of windings coupled in a wye configuration with a first terminal of a plurality of inputs
30 respectively coupled to a different one of the

plurality of phase outputs and a second terminal of the windings coupled to the neutral and a phase output coupled to each of the windings, the transformer having a secondary with a plurality of secondary windings connected in a delta configuration; and wherein

5 the phase outputs of the transformer each respectively are for connection to a separate phase of an unbalanced multiple phase load.

2. A multiple phase inverter in accordance with claim 1 wherein:

10 the transformer is a step up transformer with a DC potential applied across switches in the inverter which is less than a maximum potential of the phase outputs.

3. A multiple phase inverter in accordance with claim 2 wherein:

15 the conductive interval of each switch is pulse width modulated during a cycle of current with a duty cycle proportional to a desired magnitude of current on a different one of the phase outputs.

4. A multiple phase inverter in accordance with claim 3 wherein:

20 three phases and three pairs of switches are contained in the multiple phase inverter.

5. A multiple phase inverter in accordance with claim 1 wherein:

25 the inverter is for use in an airframe.

6. A multiple phase inverter with a neutral comprising:

5 a plurality of pairs of phase switches, each pair of phase switches being connected in series between first and second reference potentials, each switch being switched between conductive and non-conductive states;

10 a plurality of outputs each respectively coupled at a junction between a different pair of the plurality of pairs of switches;

15 means for causing each switch of a pair of switches which is coupled to one of the first and second reference potentials to be conductive for an interval and for causing at least one other switch of one of the pairs of switches which is coupled to the other of the first and second reference potentials to also be conductive during the interval to provide a path for current between the switches without a neutral connecting the conductive switches to the load;

20 a filter having a plurality of inputs coupled respectively to a different one of the outputs and forming a neutral, the filter shunting frequency components above a fundamental frequency to the neutral and providing a plurality of different phase outputs at
25 the fundamental frequency determined by a switching rate of the pairs of switches;

30 a multiple phase transformer having windings in an interconnected star configuration with a first terminal of a plurality of inputs respectively coupled to a different one of the plurality of outputs and a second terminal of the windings coupled to the neutral

and a phase output coupled to each of the windings; and wherein

5 the phase outputs of the transformer are each respectively for connection to a separate phase of an unbalanced multiple phase load.

7. A multiple phase inverter in accordance with claim 6 wherein:

10 the transformer is a step up transformer with a DC potential applied across switches in the inverter which is less than a maximum potential of the phase outputs.

8. A multiple phase inverter in accordance with claim 7 wherein:

15 the conductive interval of each switch is pulse width modulated during a cycle of current with a duty cycle proportional to a desired magnitude of current on a different one of the phase outputs.

9. A multiple phase inverter in accordance with claim 8 wherein:

20 three phases and three pairs of switches are contained in the multiple phase inverter.

10. A multiple phase inverter in accordance with claim 9 wherein:

25 the inverter is for use in an airplane.

FIG. 1
(PRIOR ART)

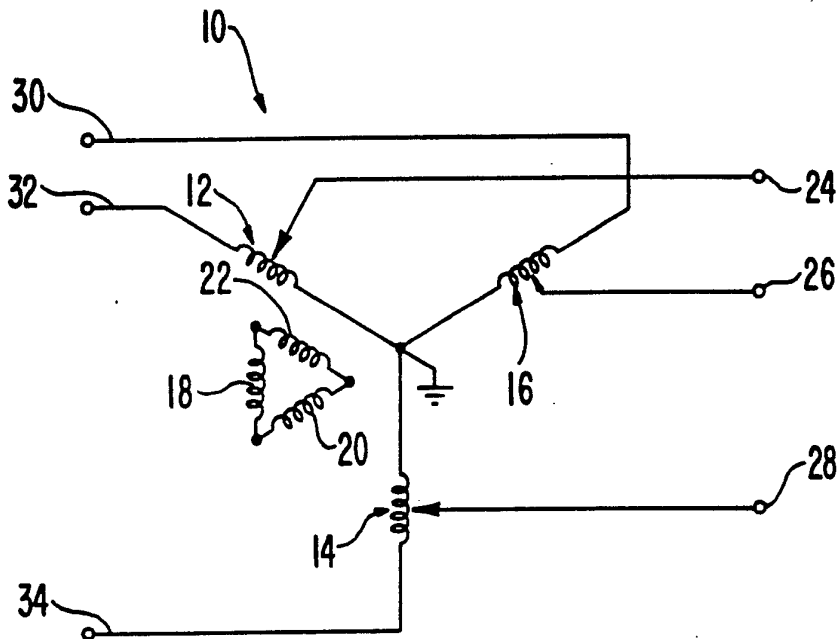

FIG. 2A
(PRIOR ART)

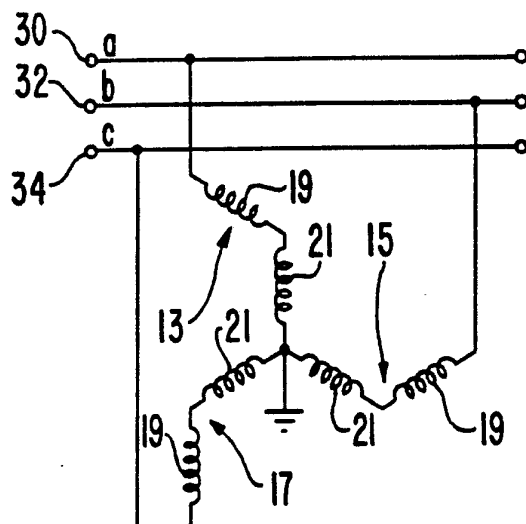

FIG. 2B
(PRIOR ART)

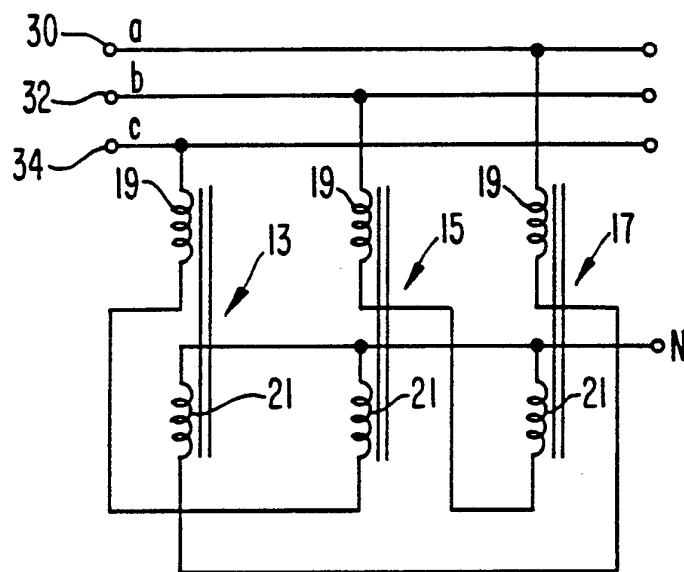
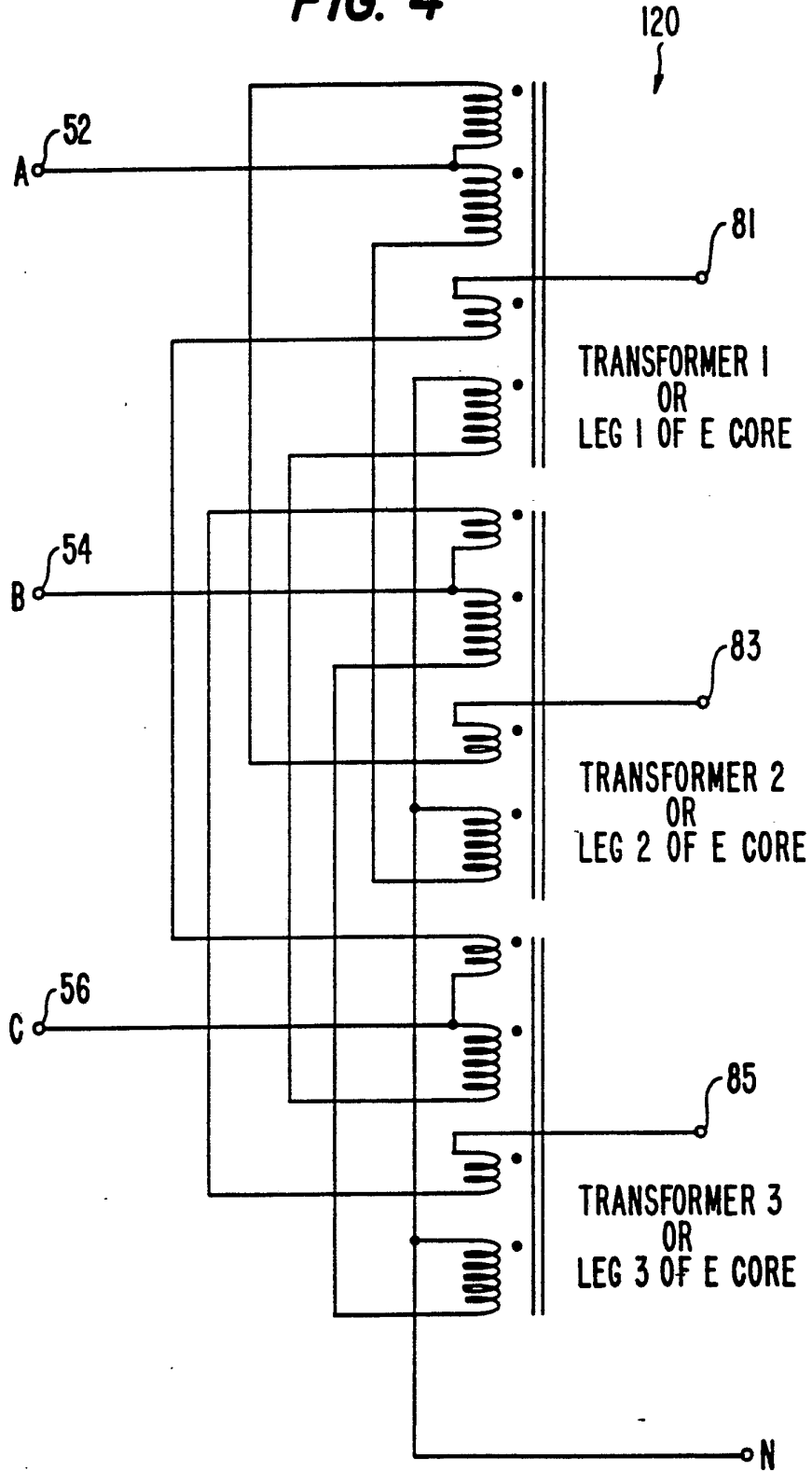

FIG. 4



INTERNATIONAL SEARCH REPORT

International Application No. PCT/US89/04441

I. CLASSIFICATION OF SUBJECT MATTER (if several classification symbols apply, indicate all) ⁶				
According to International Patent Classification (IPC) or to both National Classification and IPC				
IPC(5) : H02M 7/5387				
US. Cl : 363/132				
II. FIELDS SEARCHED				
Minimum Documentation Searched ⁷				
Classification System	Classification Symbols			
US	323/361 363/40, 132, 137			
Documentation Searched other than Minimum Documentation to the Extent that such Documents are Included in the Fields Searched ⁸				
III. DOCUMENTS CONSIDERED TO BE RELEVANT ⁹				
Category ⁹	Citation of Document, ¹¹ with indication, where appropriate, of the relevant passages ¹²	Relevant to Claim No. ¹³		
A	US, A, 3,775,663 (Turnbull) 27 November 1973 See entire document.	1-10		
A	US, A, 3,876, 923 (Humphrey et al.) 08 April 1975 See entire document.	1-10		
A	US, A, 4,500,829 (Specht et al.) 19 February 1985 See entire document.	1-10		
A	US, A, 4,513,240 (Putnam) 23 April 1985 See entire document.	1-10		
A	US, A, 4,532,581 (Miyairi) 30 July 1985 See entire document.	1-10		
<table style="width: 100%; border: none;"> <tr> <td style="width: 50%; vertical-align: top;"> <p>¹⁰ Special categories of cited documents:</p> <p>"A" document defining the general state of the art which is not considered to be of particular relevance</p> <p>"E" earlier document but published on or after the international filing date</p> <p>"L" document which may throw doubts on priority claim(s) or which is cited to establish the publication date of another citation or other special reason (as specified)</p> <p>"O" document referring to an oral disclosure, use, exhibition or other means</p> <p>"P" document published prior to the international filing date but later than the priority date claimed</p> </td> <td style="width: 50%; vertical-align: top;"> <p>"T" later document published after the international filing date or priority date and not in conflict with the application but cited to understand the principle or theory underlying the invention</p> <p>"X" document of particular relevance: the claimed invention cannot be considered novel or cannot be considered to involve an inventive step</p> <p>"Y" document of particular relevance: the claimed invention cannot be considered to involve an inventive step when the document is combined with one or more other such documents, such combination being obvious to a person skilled in the art.</p> <p>"A" document member of the same patent family</p> </td> </tr> </table>			<p>¹⁰ Special categories of cited documents:</p> <p>"A" document defining the general state of the art which is not considered to be of particular relevance</p> <p>"E" earlier document but published on or after the international filing date</p> <p>"L" document which may throw doubts on priority claim(s) or which is cited to establish the publication date of another citation or other special reason (as specified)</p> <p>"O" document referring to an oral disclosure, use, exhibition or other means</p> <p>"P" document published prior to the international filing date but later than the priority date claimed</p>	<p>"T" later document published after the international filing date or priority date and not in conflict with the application but cited to understand the principle or theory underlying the invention</p> <p>"X" document of particular relevance: the claimed invention cannot be considered novel or cannot be considered to involve an inventive step</p> <p>"Y" document of particular relevance: the claimed invention cannot be considered to involve an inventive step when the document is combined with one or more other such documents, such combination being obvious to a person skilled in the art.</p> <p>"A" document member of the same patent family</p>
<p>¹⁰ Special categories of cited documents:</p> <p>"A" document defining the general state of the art which is not considered to be of particular relevance</p> <p>"E" earlier document but published on or after the international filing date</p> <p>"L" document which may throw doubts on priority claim(s) or which is cited to establish the publication date of another citation or other special reason (as specified)</p> <p>"O" document referring to an oral disclosure, use, exhibition or other means</p> <p>"P" document published prior to the international filing date but later than the priority date claimed</p>	<p>"T" later document published after the international filing date or priority date and not in conflict with the application but cited to understand the principle or theory underlying the invention</p> <p>"X" document of particular relevance: the claimed invention cannot be considered novel or cannot be considered to involve an inventive step</p> <p>"Y" document of particular relevance: the claimed invention cannot be considered to involve an inventive step when the document is combined with one or more other such documents, such combination being obvious to a person skilled in the art.</p> <p>"A" document member of the same patent family</p>			
IV. CERTIFICATION				
Date of the Actual Completion of the International Search	Date of Mailing of this International Search Report			
10 January 1990	15 FEB 1990			
International Searching Authority	Signature of Authorized Officer			
ISA/US	Jeffrey Sterrett <i>Jeffrey Sterrett</i>			