



(11) **EP 2 192 577 A1**

(12) **EUROPEAN PATENT APPLICATION**

(43) Date of publication:
02.06.2010 Bulletin 2010/22

(51) Int Cl.:
G10L 19/02 (2006.01)

(21) Application number: **08170396.9**

(22) Date of filing: **01.12.2008**

(84) Designated Contracting States:
AT BE BG CH CY CZ DE DK EE ES FI FR GB GR HR HU IE IS IT LI LT LU LV MC MT NL NO PL PT RO SE SI SK TR
Designated Extension States:
AL BA MK RS

(74) Representative: **Patel, Binesh et al**
Barker Brettell LLP
138 Hagley Road
Edgbaston
West Midlands B16 9PW (GB)

(71) Applicant: **Research In Motion Limited**
Waterloo, Ontario N2L 3W8 (CA)

Remarks:
A request for correction of the claims has been filed pursuant to Rule 139 EPC. A decision on the request will be taken during the proceedings before the Examining Division (Guidelines for Examination in the EPO, A-V, 3.).

(72) Inventors:
• **Wu, Guixing**
Ontario, N2L 3Y1 (CA)
• **Yang, En-hui**
Ontario, N2T 2R8 (CA)

(54) **Optimization of MP3 encoding with complete decoder compatibility**

(57) An iterative rate-distortion optimization algorithm for MPEG I/II Layer-3 (MP3) encoding based on the method of Lagrangian multipliers. Generally, an iterative method is performed such that a global quantization step size is determined while scale factors are fixed, and thereafter the scale factors are determined while the global quantization step size is fixed. This is repeated until a calculated rate-distortion cost is within a predetermined threshold. The methods are demonstrated to be computationally efficient and the resulting bit stream is fully standard compatible.

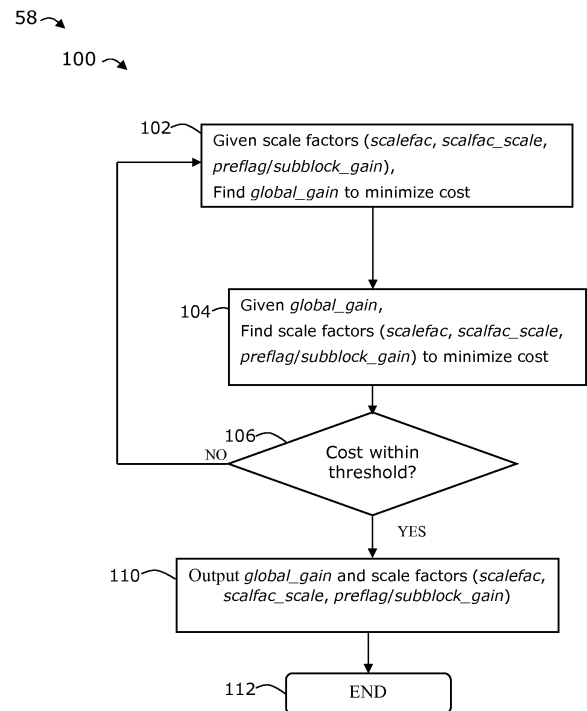

FIG. 5

Description

FIELD

5 **[0001]** Example embodiments herein relate to audio signal encoding, and in particular to rate-distortion optimization for MP3 encoding.

BACKGROUND

10 **[0002]** Many compression standards have been developed and evolved for the efficient use of storage and/or transmission resources. Among these standards is the audio coding scheme MPEG I/II Layer-3 (conventionally referred to as "MP3"), which has been a popular audio coding method since its inception in 1991. MP3 has greatly facilitated the storage and access of audio files. MP3 is now widely used in the Internet, portable audio devices and wireless communications.

15 **[0003]** An example MP3 encoder is LAME, which refers to "LAME Ain't an Mp3 Encoder", as is known in the art. Another MP3 encoder is ISO reference codec, which is based on the ISO standard. Generally, such MP3 encoders include use of two nested loop search (TNLS) algorithms, which are computationally complex and may not be guaranteed to converge. These encoders may be configured or operated to provide for additional functionality and customization.

20 **[0004]** Generally, although the encoding algorithm is not standardized in MP3, the basic structure and syntax-related tools are fixed so that the MP3 encoded/compressed bitstreams can be correctly decoded by any standard compatible decoder. However, there may be opportunities to manipulate the encoding algorithm while maintaining full decoder compatibility.

BRIEF DESCRIPTION OF THE DRAWINGS

25 **[0005]** Reference will now be made, by way of example, to the accompanying drawings which show example embodiments of the present application, and in which:

[0006] Figure 1 shows an MP3 encoding process to which example embodiments may be applied;

[0007] Figure 2 shows a flow diagram of an optimization process in accordance with an example embodiment;

30 **[0008]** Figure 3 shows a graph of an optimal path search algorithm for use in the process of Figure 2;

[0009] Figure 4 shows the graph of Figure 3, illustrating an optimal path;

[0010] Figure 5 shows a flow diagram of a process to be used in the optimization process of Figure 2;

[0011] Figure 6 shows a graph of performance characteristics of an example embodiment, for encoding of audio file waltz.wav as compared to ISO reference codec;

35 **[0012]** Figure 7 shows a graph of performance characteristics of an example embodiment, for encoding of audio file waltz.wav as compared to LAME;

[0013] Figure 8 shows a graph of performance characteristics of an example embodiment, for encoding of audio file violon.wav as compared to ISO reference codec;

40 **[0014]** Figure 9 shows a graph of performance characteristics of an example embodiment, for encoding of audio file violin.wav as compared to LAME; and

[0015] Figure 10 shows an encoder for optimizing encoding performance of MP3 in accordance with an example embodiment.

DESCRIPTION OF EXAMPLE EMBODIMENTS

45 **[0016]** It would be advantageous to provide an iterative optimization algorithm to jointly optimize quantized coefficient sequences, quantization factors, Huffman coding and Huffman coding region partition for MP3 encoding.

[0017] It would be advantageous to provide for efficient optimization of quantization factors.

50 **[0018]** In one aspect, the present application provides a method for optimizing audio encoding of a source sequence, the encoding being dependent on quantization factors, the quantization factors including a global quantization step size and scale factors. The method includes defining a cost function of the encoding of the source sequence, the cost function being dependent on the quantization factors. The method includes initializing fixed values of the scale factors; and determining values of the quantization factors which minimize the cost function by iteratively performing:

55 **[0019]** determining, for the fixed values of the scale factors, a value of the global quantization step size which minimizes the cost function,

[0020] fixing the determined value of the global quantization step size and determining values of scale factors which minimize the cost function, and fixing the determined values of the scale factors, and

[0021] determining whether the cost function is below a predetermined threshold, and if so ending the iteratively

performing.

[0022] In another aspect, the present application provides a method for optimizing audio encoding of a source sequence based on minimizing of a cost function, the cost function being a function of quantization distortion and encoding bit rate, the cost function including λ as a function that represents the tradeoff of encoding bit rate for quantization distortion, the method comprising calculating λ as the function

$$\lambda_{final}^R = \frac{c_1 \ln 10}{10M} \times 10^{(c_2 PE - c_3 R)/M}$$

wherein PE is Perceptual Entropy of an encoded frame, R is an encoding bit rate, M is the number of audio samples to be encoded, and c_1 , c_2 and c_3 are constants; and calculating the cost function using λ .

[0023] In another aspect, the present application provides an encoder for optimizing audio encoding of a source sequence, the audio encoding being dependent on quantization factors, the quantization factors including a global quantization step size and scale factors. The encoder includes a controller, a memory accessible by the controller, a cost function of an encoding of the source sequence stored in memory, the cost function being dependent on the quantization factors; and a predetermined threshold of the cost function stored in the memory. The controller is configured to access the cost function and predetermined threshold from memory, initialize fixed values of the scale factors, and determine values of the quantization factors which minimize the cost function by iteratively performing:

determining, for the fixed values of the scale factors, a value of the global quantization step size which minimizes the cost function,

fixing the determined value of the global quantization step size and determining values of scale factors which minimize the cost function, and fixing the determined values of the scale factors, and

determining whether the cost function is below the predetermined threshold, and if so ending the iteratively performing.

[0024] Reference is now made to Figure 1, which shows an MP3 encoding process 20 to which example embodiments may be applied. Generally, the MP3 encoding process 20 receives digital audio input 22 and produces a compressed or encoded output 32 in the form of a bitstream for storage and transmission. The encoding process 20 may for example be implemented by an encoder such as a suitably configured computing device. In Figure 1, continuous lines denote the time or spectral domain signal flow, and dash lines denote the control information flow. As shown, the encoding process 20 includes audio input 22 for input to a time/frequency (T/F) mapping module 24 and a psychoacoustic model module 26. Also shown are a quantization and entropy coding module 28 and a frame packing module 30. The encoding process 20 results in an encoded output 32 of the audio input 22, for example for sending to a decoder for subsequent decoding.

[0025] The audio input 22 (in time domain) are first input into the T/F mapping module 24, which converts the audio input 22 into spectral coefficients. The T/F mapping module 24 is composed of three steps: pseudo-quadrature mirror filter (PQMF), windowing and modified discrete cosine transform (MDCT), and aliasing reduction. The PQMF filterbank splits a so-called granule (in MPEG I and II layer 3 each audio frame contains 2 and 1 granules respectively) of 576 input audio samples into 32 equally spaced subbands, where each subband has 18 time domain audio samples. The 18 time domain audio samples in each subband are then combined with their counterpart of the next frame, and processed by a sine-type window based on psychoacoustic modeling decisions. A long window, which covers a whole length of 36, addresses stationary audio parts. Long windowing with MDCT afterwards ensures a high frequency resolution, but also causes quantization errors spreading over the 1152 time-samples in the process of quantization. A short window is used to reduce the temporal noise to spread for the signals containing transients/attacks. In the short window, audio signals with a length of 36 are divided into 3 equal sub-blocks. In order to ensure a smooth transition from a long window to a short window and vice versa, two transition windows, long-short (start) and short-long (stop), which have the same size as a long window, are employed.

[0026] The psychoacoustic model module 26 is generally used to generate control information for the T/F mapping module 24, and for the quantization and entropy coding module 28. Based on the control information from the psychoacoustic model module 26, the spectral coefficients which are output from the T/F mapping module 24 are received by the quantization and entropy coding module 28, and are quantized and entropy coded. Finally these compressed bits streams are packed up along with format information, control information and other auxiliary data in MP3 frames, and

output as the encoded output 32.

[0027] The MP3 syntax leaves the selection of quantization step sizes and Huffman codebooks to each encoder or encoding algorithm, which provides opportunity to apply rate-distortion consideration. A conventional MP3 encoding algorithm is now be described as follows, which employs a "hard decision quantization", a two nested loop search (TNLS) algorithm, and fixed or static Huffman codebooks.

[0028] The MP3 quantization and entropy coding module 28 first subdivides an entire frame of 576 spectral coefficients into 21 or 12 scale factor bands for a long window block (including long-short window and short-long window) or a short window block respectively. Each coefficient x_i , $i=0$ to 575, is quantized by the following non-uniform quantizer:

$$y_i = n \text{int} \left[\left(\frac{|x_i|}{(\sqrt[4]{2})^{global_gain-210-scale_factor[sb]}} \right)^{0.75} - 0.0946 \right] \quad (2.1)$$

where y_i denotes the quantized index, $n \text{int}$ denotes the nearest non-negative integer, $global_gain$ is a global quantization step size which determines the overall quantization step size for the entire frame, and $scale_factor[sb]$ is used to determine the actual quantization step size for scale factor band sb where the spectral coefficient x_i lies ($sb=0$ to 11 for short blocks, $sb=0$ to 20 for other blocks) to make the perceptually weighted quantization noise as small as possible. The formulaic determination of y_i as in (2.1) may be referred to as "hard decision quantization".

[0029]

The $scale_factor[sb]$ is expressed as

$$scale_factor[sb] \approx 2 \cdot (scalefac[sub_block][sb] + preflag \cdot pretab[sb]) \times (1 + scalefac_scale) + 8 \times subblock_gain[sub_block]. \quad (2.2)$$

[0030] Generally, each of the parameters listed in (2.2) may be referred to as a "scale factor", and all of which may be collectively referred to herein as "scale factors", as appropriate. $global_gain$ and the scale factors may collectively be referred to herein as "quantization factors".

[0031] In (2.2), sub_block is only used for short windows, and it refers to one of the 3 sub-blocks for a short window. $scalefac[sub_block][sb]$ is a scale factor parameter for scale factor band sb to color the quantization noise. $scalefac[sub_block][sb]$ are variable length transmitted according to $scalefac_compress$ which occupies 4 bits (MPEG-1) or 9 bits (MPEG-2) in the side information of MP3 encoded frames. $preflag$ is a shortcut for additional high frequency amplification of the quantized values. If $preflag$ is set, the values of a fixed table $pretab[sb]$ are added to the scale factors. $preflag$ is never used in short windows (for the purposes of the standard). $subblock_gain[sub_block]$ is the gain offset for the short window. $scalefac_scale$ is a one-bit parameter used to control the quantization step size.

[0032] The quantized spectral coefficients are then encoded by static Huffman coding, which utilizes 34 fixed Huffman codebooks. To achieve greater coding efficiency, MP3 subdivides the entire quantized spectrum into three regions. Each region is coded with a different set of Huffman codebooks that best match the statistics of that region. Specifically, at high frequencies, MP3 identifies a region of "all zeros". The size of this region can be deduced from the sizes of the other two regions, and the coefficients in this region don't need to be coded. The only restriction is that it must contain an even number of zeros since the other two regions group their values in 2- or 4-tuples. The second region, called "count 1" region, contains a series of contiguous values consisting only of -1, 0, +1 just before the "zero" region, and is encoded in 4-tuples by Huffman codebook 32 or 33. Finally the low frequency region, called "big value" region, covers the remaining coefficients which are encoded in pairs. This region is further subdivided into 3 (for long window) or 2 (for short, long-short and short-long window) parts with each covered by a distinct Huffman codebook.

[0033] To minimize the quantization noise, a noise shaping method may be applied to find the proper global quantization step size $global_gain$ and scale factors before the actual quantization. Some conventional algorithms use the TNLS algorithm to jointly control the bit rate and distortion. The TNLS algorithm consists of an inner (rate control) loop and an outer (noise control) loop. The task of the inner loop is to change the global quantization step size $global_gain$ such that the given spectral data can just be encoded with the number of bits available. If the number of bits resulting from Huffman coding exceeds this number, the $global_gain$ can be increased to result in a larger quantization step size, leading to smaller quantized values. This operation is repeated until the resulting bit demand for Huffman coding is small enough. The TNLS algorithm may require quantization step sizes so small to obtain the best perceptual quality. On the other hand, it has to increase to the quantization step sizes to enable coding at the required bit rate. These two requirements are conflicting. Therefore, this conventional algorithm does not guarantee to converge.

[0034] In some example embodiments, soft decision quantization, instead of the hard decision quantization, is applied, and the corresponding purpose of quantization and entropy coding in MP3 encoding is to achieve the minimum perceptual distortion for a given encoding bit rate by solving, mathematically, the following minimization problem:

5

$$\begin{cases} \min_{\mathbf{y}, \mathbf{q}, \mathbf{P}, \mathbf{H}} D_w(\mathbf{xr}, \mathbf{rxr}), \text{ subject to} \\ R(\mathbf{q}) + R(\mathbf{y}, \mathbf{P}, \mathbf{H}) \leq R_1 \end{cases} \quad (3.1)$$

10

where \mathbf{xr} is the original spectral signal, \mathbf{rxr} is the reconstructed signal obtained from the quantized spectral coefficients \mathbf{y} , \mathbf{P} and \mathbf{H} represent Huffman codebook region partition and Huffman codebooks selection respectively, \mathbf{q} denotes the quantization factors including *global_gain* and scale factors, $R(\mathbf{q})$ and $R(\mathbf{y}, \mathbf{P}, \mathbf{H})$ are the bit rates to encode \mathbf{q} and the quantized spectral coefficients \mathbf{y} respectively, R_1 is the rate constraint, and $D_w(\mathbf{xr}, \mathbf{rxr})$ denotes the weighted distortion measure between \mathbf{xr} and \mathbf{rxr} . Note that here \mathbf{y} is not calculated according to (2.1) any more; instead, it is treated as a variable in a cost function involving the distortion and rates, and has to be determined jointly along with \mathbf{q} , \mathbf{P} , and \mathbf{H} . Average noise-to mask ratio (ANMR) is used as the distortion measure. The noise-to mask ratio (NMR), the ratio of the quantization noise to the masking threshold, is a widely used objective measure for the evaluation of an audio signal. ANMR is expressed as

20

$$ANMR = \frac{1}{N} \sum_{sb=1}^N w[sb] \cdot d[sb] \quad (3.2)$$

25

where N is the number of scale factor bands, $w[sb]$ is the inverse of the masking threshold for scale factor band sb , and $d[sb]$ is the quantization distortion, mean squared quantization error for scale factor band sb .

[0035] The above constrained optimization problem could be converted into the following minimization problem:

30

$$\min_{\mathbf{y}, \mathbf{q}, \mathbf{P}, \mathbf{H}} J_\lambda(\mathbf{y}, \mathbf{q}, \mathbf{P}, \mathbf{H}) = D_w(\mathbf{xr}, \mathbf{rxr}) + \lambda \cdot (R(\mathbf{q}) + R(\mathbf{y}, \mathbf{P}, \mathbf{H})) \quad (3.3)$$

where λ is a fixed parameter that represents the tradeoff of rate for distortion, and J_λ is referred to as the "Lagrangian cost".

[0036] Reference is now made to Figure 2, which shows a flow diagram of an optimization process 50 in accordance with an example embodiment. The exact order of steps may vary from those shown in Figure 2 in different applications and embodiments. It can also be appreciated that more or less steps may be required in some example embodiments, as appropriate. To find an optimum J_λ , the parameters \mathbf{y} , \mathbf{q} , \mathbf{P} and \mathbf{H} are jointly optimized. The general framework for the process 50 has been outlined previously in Xu and E.-h. Yang, "Rate-distortion optimization for MP3 audio coding with complete decoder compatibility," in Proc. 2005 IEEE Workshop on Multimedia Signal Processing, Oct. 2005, the contents of which are herein incorporated by reference. Generally, the process 50 selects the quantized spectral coefficients \mathbf{y} and Huffman codebook region division \mathbf{P} , quantization factors \mathbf{q} and Huffman codebook region selection \mathbf{H} alternatively to minimize the Lagrangian cost J . The iterative searching for the parameters may be referred to as "soft-decision quantization" (rather than the formulaic "hard-decision quantization" of (2.1), described above).

40

[0037] Referring still to Figure 2, the iterative algorithm of the process 50 can be described as follows. At step 52, specify a tolerance ϵ as the convergence criterion for the Lagrangian cost J . At step 54, initialize a set of quantization factors \mathbf{q}_0 from the given frame of spectral domain coefficients \mathbf{xr} with a Huffman codebooks selection mode \mathbf{H}_0 ; and set $t=0$.

45

[0038] At step 56, \mathbf{q}_t and \mathbf{H}_t are fixed or given for any $t \geq 0$. Find the optimal quantized spectral coefficients \mathbf{y}_t and Huffman codebook region division \mathbf{P}_t by soft decision quantization, where \mathbf{y}_t and \mathbf{P}_t achieve the minimum

50

$$\min_{\mathbf{y}, \mathbf{P}} J_\lambda = D_w(\mathbf{xr}, Q^{-1}(\mathbf{q}, \mathbf{y})) + \lambda \cdot (R(\mathbf{q}_t) + R(\mathbf{y}, \mathbf{P}, \mathbf{H}_t)) \quad (3.4)$$

55

where the inverse quantization function $Q^{-1}(\mathbf{q}, \mathbf{y})$ is used to generate the reconstructed signal \mathbf{rxr} . Denote $J_\lambda(\mathbf{y}_t, \mathbf{q}_t, \mathbf{P}_t$,

\mathbf{H}_t) by J'_λ .

[0039] At step 58, given \mathbf{y}_t , \mathbf{P}_t and \mathbf{H}_t , update \mathbf{q}_t to \mathbf{q}_{t+1} so that \mathbf{q}_{t+1} achieves the minimum

5

$$\min_{\mathbf{q}} J_\lambda = D_w(\mathbf{xr}, Q^{-1}(\mathbf{q}, \mathbf{y})) + \lambda \cdot (R(\mathbf{q})) \quad (3.5)$$

[0040] At step 60, given \mathbf{y}_t , \mathbf{P}_t and \mathbf{q}_{t+1} , update \mathbf{H}_t to \mathbf{H}_{t+1} so that \mathbf{H}_{t+1} achieves the minimum

10

$$\min_{\mathbf{H}} R(\mathbf{y}_t, \mathbf{P}_{t+1}, \mathbf{H}_t). \quad (3.6)$$

15

[0041] At step 62, query whether $J'_\lambda - J^{t+1}_\lambda \leq \varepsilon \cdot J'_\lambda$. If so, the optimization process 50 proceeds to step 66 and outputs the final \mathbf{y} , \mathbf{q} , \mathbf{P} and \mathbf{H} and ends at step 68. If not, proceed to step 64 wherein $t=t+1$, and repeat steps 56, 58

20

and 60 for $t=0, 1, 2, \dots$ until $J'_\lambda - J^{t+1}_\lambda \leq \varepsilon \cdot J'_\lambda$. Since the Lagrangian cost function may be non-increasing at each step, the convergence is guaranteed. The final \mathbf{y} , \mathbf{q} , \mathbf{P} and \mathbf{H} may thereafter be provided for MP3 coding of \mathbf{xr} .

[0042] Referring still to Figure 2, an example embodiment of step 56 will now be described in greater detail, with reference now to Figures 3 and 4. Figure 3 shows a graph 80 of an optimal path search algorithm for use in the process of Figure 2; while Figure 4 shows an optimal path of the graph 80.

25

[0043] Without being limiting, consider for example the long window case. The graph 80 is defined with 4 layers (shown as I, II, III, and IV) and 288 nodes in each layer as shown in Figure 3. The 4 layers correspond to the three divisions of the *big_value* region and the *count_1* region. Each state $S_{L,j}$ ($L=I, \dots, IV, 0 \leq j < 288$) in layer L stands for two neighboring coefficients xr_{2j} and xr_{2j+1} to be quantized, since Huffman coding is always applied on 2-(for layer I, II, III) or 4-(for layers IV) tuples. Two special states, *frame_begin* and *frame_end*, denote the start and end of the frame respectively. Connection between any two states denotes a Huffman codebook region division decision pair: state $S_{L,j}$ may have incoming connections from states $S_{M,j}$ ($M=1, \dots, L; j=i-2$ if $L=IV$, and $j=i-1$ otherwise), each of which represents the decision of assigning node i , i.e., coefficients xr_{2i} and xr_{2i+1} to the Huffman codebook region denoted by layer L. Note that not all the states and paths are compatible with the standard and the following syntax constraints should be observed for the construction of the graph 80:

35

- a) States of scale factor band 0 in layers II and III, states of scale factor band 1 in layer III, and the second state in layer IV are illegitimate, and thus don't have any incoming and outgoing connections;
- b) States after scale factor band 15 in Layer I are not allowed;
- c) A graph path cannot transverse more than 8 scale factor bands in layer II;
- d) The connections among layers I, II and III can only occur at the scale factor band boundaries, and the *frame_begin* state has only outgoing connections to states $S_{I,0}$ and $S_{IV,0}$ and *frame_end*; and
- e) The *frame_end* state has incoming connections from all legitimate states, with each connection from non-trailing state $S_{L,i}$ ($0 \leq i < 287$) representing the decision of assigning the coefficients after node i to the zero region, that is, dropping that part of spectrum without Huffman encoding and transmission.

40

45

[0044] Assign to each connection from previous states (no matter which layer they lie in) to state $S_{L,i}$ ($0 \leq i < 288$) a cost which is defined as the minimum incremental Lagrangian cost of quantizing and Huffman encoding the coefficients of state $S_{L,i}$ (or states $S_{L,i-1}$ and $S_{L,i}$ if $L=IV$) by using the Huffman codebook selected for layer L. Specifically, this minimum incremental cost is equal to

50

$$\min_{y_{2i-k}, \dots, y_{2i}} \sum_{j=2i-k}^{2i} D_w(xr_j, Q^{-1}(q_j, y_j)) + \lambda \cdot r_L(y_{2i-k}, \dots, y_{2i}) \quad (3.7)$$

55

where $k=3$ if $L=IV$, and $k=1$ otherwise, $y_j, j=2i-k, \dots, 2i$, is the j th quantized coefficient, q_j is the corresponding scale factor for y_j , and $r_L(\dots)$ denotes the codeword length by using the Huffman codebook selected for layer L. Similarly, for the connection from state $S_{L,i}$ ($0 \leq i < 287$) to the *frame_end* state, its cost is defined as

$$\sum_{j=2i-k}^{576} D_w(xr_j, Q^{-1}(q_j, 0)) + \lambda \cdot 0 = \sum_{j=2i-k}^{576} D_w(xr_j, Q^{-1}(q_j, 0)) \quad (3.8)$$

- 5
- [0045]** No cost is assigned to the connections from trailing state $S_{L,288}$ to the *frame_end* state.
- [0046]** With the above definitions, every sequence of connections from the *frame_begin* state to the *frame_end* state corresponds to a Huffman codebook region division of the entire frame with a Lagrangian cost. For example, the sequence of connection in Figure 4 assigns scale factor band 0 and 1 to the first two subdivisions of the *big_value* region respectively, the next 4 coefficients to the *count_1* region, and the rest to the *zero* region. On the other hand, any Huffman codebook region division of the entire frame that is compatible with the standard can be represented by a sequence of connections from the *frame_begin* to the *frame_end* state in the graph 80. Hence the optimal path from the *frame_begin* state to the *frame_end* state, together with quantized coefficients along each connection that give the minimum cost defined by (3.7), achieves the minimum in step 56 (Figure 2) for any given **q** and **H**.
- 10
- [0047]** An elaborate step-by-step description of the path searching algorithm is described as follows, referring still to Figures 3 and 4. As an initialization, the algorithm preselects and stores the best quantized coefficients based on minimizing the Lagrangian cost of (3.7) for each legitimate state $S_{L,i}$ and sets their associated cost as the cost of each connection to that state. The algorithm also recursively precalculates, for each state, the distortion/cost resulting from ending the frame at that state, i.e., the cost of its connection to the state *frame_end*. The algorithm begins with the state *frame_begin* by storing the cost of dropping the entire frame in J_{frame_begin} . Then, one proceeds to state $S_{L,0}$ ($L=I, \dots, IV$), among which only states $S_{I,0}$ and $S_{IV,0}$ have incoming connections from the state *frame_begin*. The cost of each state is set to the cost of corresponding incoming connection, and added with the cost of dropping the remaining coefficients to get $J_{I,0}$ and $J_{IV,0}$, respectively. Proceeding to state $S_{L,1}$ ($L=I, \dots, IV$), only states $S_{L,1}$ has an incoming connection from states $S_{I,0}$. Set its cost to the sum of the costs of state $S_{I,0}$ and the connection between $S_{I,0}$ and $S_{I,1}$, and add it with the cost of dropping the remaining coefficients to get $J_{I,1}$. Next, consider states $S_{L,2}$ ($L=I, \dots, IV$), it may be observed that $S_{IV,2}$ has two incoming connections from $S_{IV,0}$ and $S_{I,1}$ respectively. Here the connection from the state with less cost is chosen, and the costs of $S_{IV,2}$ and $J_{IV,2}$ are computed by adding it with corresponding incremental connection costs, respectively. Following the above cost computation rule, process all legitimate states: for each state $S_{L,i}$, the best incoming connection is selected such that the accumulated cost (from *frame_begin* to $S_{L,i}$) can be minimized. Store this connection selection decision at that state, set the cost of $S_{L,i}$ to the accumulated cost, and then sum it with the cost of dropping the remaining coefficients to get $J_{L,i}$.
- 20
- [0048]** Referring now to Figure 4, after traversing all the legitimate states, the path cost information, $J_{L,i}$, $L=I, \dots, IV$, $0 \leq i < 288$, is available. Obtain the minimum path cost $J_{min} = \min_{L,i} J_{L,i}$. By backtracking the path which gives J_{min} with the help of the stored information in each state, the optimal quantized spectral coefficients **y** and region division **P** that solve the problem (3.4) may be obtained.
- 25
- [0049]** In a similar manner as described above, a three-layer graph could be constructed for other three window cases.
- [0050]** Referring to Figure 2, step 58 will now be described in greater detail, with reference now to Figure 5. Figure 5 shows an example embodiment of a process 100 to be used in step 58 of Figure 2. Step 58 generally determines the quantization factors **q** (i.e., scale factors and *global_gain*) that minimize the combined cost of weighted distortion and bit rate for encoding or transmittal. Given the nonuniform quantizer and nonlinear bit rate for quantization factors in the standard, there is no direct formula to calculate the optimal quantization factors. Direct search through all combinations of *global_gain*, *scalefac_compress*, *scalefac*, *scalfac_scale*, and *subblock_gain* (for short windows) or *preflag* (for other windows) may be computationally complex. Take an MPEG-1 encoded long-block frame as an example. There are 256 different cases for *global_gain*, *scalefac_compress*, *preflag* and *scalfac_scale* have 16, 2 and 2 different cases respectively. There are $256 \times 16 \times 2 \times 2 = 16384$ different combinations to find the minimum combined cost. In some example embodiments, to reduce the computational complexity, the method 100 includes the following alternating minimization procedure to minimize the combined cost. Generally, at step 102 *global_gain* is determined while the scale factors are fixed, and at step 104 the scale factors are determined while *global_gain* is fixed. This is repeated iteratively until the calculated rate-distortion cost is within a predetermined threshold.
- 30
- [0051]** At step 102, update *global_gain* when *scalefac*, *scalfac_scale* and *subblock_gain* (for short windows) or *preflag* (for other windows) are fixed. In this case, the bit rate for the transmission of scale factors is fixed. Therefore, at this stage only the encoding distortion is minimized, while rate is not considered. The weighted distortion for scale factor band *sb* is
- 35
- 40
- 45
- 50

$$d_w[sb] = w[sb] \cdot \sum_{i=l[sb]}^{l[sb+1]-1} [xr_i - y_i^{4/3} 2^{s(sb)/4}]^2 \quad (3.9)$$

55

where $s[sb] = global_gain - 210 - scale_factor[sb]$, $l[sb]$ and $l[sb+1]-1$ are the start and end positions for scale factor band sb respectively, $w[sb]$ is the inverse of the masking threshold for scale factor band sb . The total average weighted distortion D_w for an encoded frame could be expressed as

$$D_w = \frac{1}{N} \sum_{sb=1}^N d_w[sb] = \frac{1}{N} \sum_{sb=1}^N w[sb] \cdot \sum_{i=l[sb]}^{l[sb+1]-1} [xr_i - y_i^{4/3} 2^{s(sb)/4}]^2 \quad (3.10)$$

[0052] Differentially calculate the distortion based on encoding with respect to $global_gain$ to minimize the distortion.

Let $\frac{\partial D}{\partial global_gain} = 0$, which leads to

$$global_gain = \frac{4}{\log_{10} 2} \log_{10} \frac{\sum_{sb=1}^N b[sb]}{\sum_{sb=1}^N a[sb]} + 210 \quad (3.11)$$

where

$$b[sb] = 2^{-scale_factor[sb]/4} \cdot w[sb] \cdot \sum_{i=l[sb]}^{l[sb+1]-1} xr_i \cdot y_i^{4/3} \quad (3.12)$$

and

$$a[sb] = 2^{-scale_factor[sb]/2} \cdot w[sb] \cdot \sum_{i=l[sb]}^{l[sb+1]-1} y_i^{4/3} \quad (3.13)$$

As $global_gain$ should be an integer, $global_gain$ is chosen as one of the two nearest integers to formula (3.11) which has smaller weighted distortion.

[0053] At step 104, fix $global_gain$. Update the scale factors $scalefac$, $scalefac_scale$ and $subblock_gain$ (for short windows) or $preflag$ (for other windows) to minimize the combined cost of weighted distortion and bit rate for transmitting the scale factors. As indicated from equation (3.9),

$$s[sb] = global_gain - 210 - scale_factor[sb],$$

where $global_gain$ has the value of 0 to 255, and $scale_factor[sb]$ is equal to

$$scale_factor[sb] = 2 \times (scalefac[sb] + preflag \cdot pretab[sb]) \times (1 + scalefac_scale). \quad (3.14)$$

[0054] $preflag$ is equal to 0 or 1. The value of $pretab[sb]$ is typically fixed and is of the form as shown in Table 1.
[0055]

Table 1. The value of *pretab[sb]* for long windows.

Sb	0 to 10	11	12	13	14	15	16	17	18	19	20
Preflag=0	0	0	0	0	0	0	0	0	0	0	0
Prefag=1 1	0	1	1	1	1	2	2	3	3	3	2

[0056] *scalefac_scale* is equal to 0 or 1.

[0057] The bit length of *scalefac[sb]* is determined by *scalefac_compress*, that is, *scalefac_compress* determines the number of bits used for the transmission of the scalefactors according to Table 2.

[0058]

Table 2: The bit length for *scalefac[sb]*

<i>scalefac_compress</i>	<i>slen 1</i>	<i>slen2</i>
0	0	0
1	0	1
2	0	2
3	0	3
4	3	0
5	1	1
6	1	2
7	1	3
8	2	1
9	2	2
10	2	3
11	3	1
12	3	2
13	3	3
14	4	2
15	4	3

[0059] As can be appreciated from Table 2, the bit length may be a first bit length for a first group of scale factor bands and the bit length may be a second bit length for a second group of scale factor bands. In Table 2 *slen1* is the bit length of *scalefac* for each of scalefactor bands 0 to 10, and *slen2* is the bit length of *scalefac* for each of scalefactor bands 11 to 20.

[0060] From the above, it can be observed that a direct search for the minimum combined cost requires the computation of encoding costs for all combinations of *scalefac_compress*, *scalefac_scale* and *preflag*. This leads to $16 \times 2 \times 2 = 64$ different combinations to find the minimum combined cost for each scalefactor band. Without intending to be limiting, the following example embodiment assumes that the encoding block is an MPEG-1 encoded, long-window frame. In some example embodiments, it is recognized that there are some redundant operations in the distortion computations. Therefore, some example embodiments provide for pre-generating a look-up table for those redundant operations, which are based on *slen* rather than searching through all combinations of *scalefac_compress*.

[0061] From Table 2, the maximum length for *slen1* is 4 while the maximum length for *slen2* is 3 (as based on the MP3 standard). When *slen1* and *slen2* are given, in some example embodiments, one can find the minimum encoding distortion for each scalefactor band and the corresponding *scalefac[sb]* which generates the minimum encoding distortion. Hence, when *preflag* and *scalefac_scale* are fixed, there only needs to be calculated 5 (the first 11 bands) or 4 (the last 10 bands) different cases of encoding distortion for each scale factor band, rather than calculate the encoding distortion 16 times for different *scalefac_compress*. In each case, the pre-calculated encoding distortion is minimized with a certain value for *scalefac[sb]* given the length *slen1* or *slen2*.

[0062] Let's denote $dist[sb][slen]$ as the minimum weighted distortion for scale factor band sb , where $sb=0, \dots, 20$ and $slen=0, \dots, 4$. Denote $sf[sb][slen]$ as the value for $scalefac[sb]$ such that the weighted distortion is minimized for scale factor band sb when the bit length used for transmitting $scalefac[sb]$ is $slen$. To generate a look-up table for each scale factor band, apply the following approach given the fixed values for $global_gain$, $scalfac_scale$ and $preflag$. Without loss of generality, the following example embodiment considers the first 11 scale factor bands for an MPEG-1 encoded, long-window frame.

[0063] Assume $s[sb]$ in equation (3.9) can be freely chosen. That is, $s[sb]$ is not restricted by the value of $scalefac[sb]$ to be one of the 16 integer numbers (0, 1, 2, 3, 4, 5, 6, 7, 8, 9, 10, 11, 12, 13, 14, 15). Apply the minimum mean square

error criterion to find the minimum weighted distortion for (3.9). That is, let $\frac{\partial d_w[sb]}{\partial s[sb]} = 0$, which leads to

$$s[sb] = \frac{4}{\log_{10} 2} \log_{10} \frac{\sum_{i=l[sb]}^{l[sb+1]-1} xr_i \cdot y_i^{4/3}}{\sum_{i=l[sb]}^{l[sb+1]-1} y_i^{8/3}} \quad (3.15)$$

[0064] Denote $sg[sb]=s[sb]+210$, The corresponding value for $scalefac[sb]$ is $(global_gain - sg[sb])/2^{(1+sCaifac_scale) - preflag \cdot pretab[sb]}$. Denote this value as T . $scalefac[sb]$ cannot be freely chosen in reality (as defined by the standard), that is, it must be constrained to one of the 16 integer numbers (0, 1, 2, 3, 4, 5, 6, 7, 8, 9, 10, 11, 12, 13, 14, 15). In some example embodiments, the value of $scalefac[sb]$ can be determined using the following algorithm. Generally, it is determined whether T exceeds encoding within $slen$, and if so constraining T to within $slen$:

If $slen=0$

$$\text{let } sf[sb][slen] = 0, \text{ and calculate the distortion } dist[sb][0]. \quad (3.16)$$

Else ($slen \neq 0$)

if $T \leq 0$

for $slen = 1$ to 4

let $sf[sb][slen] = 0$, and let $dist[sb][slen] = dist[sb][0]$.

else if $T \geq 15$

for $slen=1$ to 4

let $sf[sb][slen]=2^{slen}-1$, and calculate $dist[sb][slen]$ using equation (3.9).

else

let $sf[sb][4]=T$ (If T is not an integer, choose one of the two nearest integers to T which has smaller weighted distortion), calculate

$dist[sb][4]$ using equation (3.9)

for $slen=3$ down to 1

if $sf[sb][slen+1] \geq 2^{slen}-1$

let $sf[sb][slen]=2^{slen}-1$.

else

let $sf[sb][slen]=sf[sb][slen+1]$.

calculate $dist[sb][slen]$ using equation (3.9).

[0065] Totally there are 20 different cases ($5 slen1 \times 2 preflag \times 2 scalfac_scale$) of encoding distortion for each of the first 11 scale factor bands and 16 different cases ($4 slen2 \times 2 preflag \times 2 scalfac_scale$) of encoding distortion for each of the last 10 scale factor bands. As the setting of $preflag$ only affects the last 10 scale factor bands, the number of different cases of encoding distortion to be computed for each of the first 11 scale factor bands is reduced to 10 ($5 slen1 \times 2 scalfac_scale$). In other words, the cost function is minimized with respect to $preflag$ for only one set of scale factor bands, being the higher frequency scale factor bands 11 to 20. In addition, there exists one redundant case for each scale factor band if $scalefac[sb]$ is equal to 0 (i.e., (3.16) may be calculated once). As a result, in some example embodiments, there are 9 (the first 11 scale factor bands) or 15 (the last 10 scale factor bands) different cases of encoding distortion for each scale factor band.

[0066] After generating the above table based on encoding distortion, what remains is the calculation of the total Lagrangian cost by calculating (3.3). As described above with respect to (3.3), the total Lagrangian cost is the addition of the encoding distortion and the bit rate. Therefore, what remains is the addition of bit rate to calculate the combined cost. For example, the distortion based on bit rate for the transmission of all scale factors can also be looked up from a pre-generated table, as is known in the art. Similarly, for other window cases, a similar approach could be applied to reduce the computational complexity.

[0067] At step 106, repeat steps 102 and 104 until the decrease of the combined cost is below a prescribed threshold. If the predetermined threshold is reached, at step 110 output the final *global_gain* and scale factors (*scalefac*, *scalfac_scale*, *preflag/subblock_gain*), and then ends at step 112 (or proceed to the next step in method 50 (Figure 2)).

[0068] As the iterative method 100 generally converges after two rounds of iteration, the number of different cases to be computed for each scale factor band of an MPEG-1 encoded, long-window frame has been reduced from 16384 to 18 (the first 11 bands) or 30 (the last 10 bands).

[0069] The particular quantization factors or scale factors to be determined may depend on the particular application or coding scheme, and may not be limited to the parameters *global_gain*, *scalefac*, *scalfac_scale*, and *preflag/subblock_gain*.

[0070] Referring now to Figure 2, step 60 will now be described. Given Huffman coding region division **P**, the quantization factors **q** and quantized spectral coefficients **y**, determining the Huffman codebook **H** may be performed as follows: for each region, every Huffman codebook that has encodable value limit larger than or equal to the greatest coefficient amplitude of that region is considered, and the one with the minimum codeword length is selected.

[0071] Implementation and simulation results will now be described. In regards to (3.3), the estimation of lambda (λ) will now be described in greater detail. In conventional systems, bisection methods may be used to determine for a final λ . This may require a high computational complexity which is proportional to the number of iterations over the optimization algorithm described in the last section. As recognized herein, in some example embodiments, by analyzing the relationship between Perceptual Entropy, signal to noise ratio, signal to mask ratio, encoding bit rate and the number of audio samples to be encoded, the final λ was estimated using the following formula in a trellis search algorithm for the optimization of advance audio coding (AAC),

$$\lambda_{final}^R = \frac{c_1 \ln 10}{10M} \times 10^{(c_2 PE - c_3 R)/M} \quad (4.1)$$

where *PE* is Perceptual Entropy of an encoded frame, *R* is the encoding bit rate, and *M* is the number of audio samples to be encoded. c_1 , c_2 and c_3 are determined from the experimental data using the least square criterion. This is for example generally described in C. Bauer and M. Vinton, "Joint optimization of scale factors and Huffman codebooks for MPEG-4 AAC," in Proc. of the 2004 IEEE workshop on Multimedia Signal Processing, pp. 111-114, 2004; and C. Bauer and M. Vinton, "Joint optimization of scale factors and Huffman codebooks for MPEG-4 AAC," in IEEE Trans. on Signal Processing, vol. 54, pp. 177-189, Jan. 2006, both of which are incorporated herein by reference.

[0072] In the experiment, 16 RIFF WAVE files with a sampling rate of 44.1 khz from a sound test file were used. The initial value for λ was arbitrarily selected, and the bisection method was used to find the final value for λ . The optimized MP3 encoded files were generated for each of the 16 RIFF WAVE test files at the encoding bit rates of 32, 40, 48, 56, 64, 80, 96, 112, 128, 144, 160, 192, 224, 256 and 320 kbps. For each tested file, tested values of Perceptual Entropy and λ at different encoding bit rates were recorded. As the values of Perceptual Entropy are usually in the range of 100 to 3000, tested data outside this range was discarded. Next, uniformly quantize the values of tested Perceptual Entropy with a quantization step size of 100, and calculated the mean value and standard deviation for the tested λ for each possible encoding bit rate and perceptual entropy pair.

[0073] To determine the values of c_1 , c_2 and c_3 , a non-linear regression progress within MATLAB optimization toolbox was used in some example simulations. Specifically, use the following MATLAB function

$$\mathbf{beta} = \mathit{nlinfit}(\mathbf{X}, \mathbf{y}, \mathit{fun}, \mathbf{beta0}) \quad (4.2)$$

to estimate the coefficients of c_1 , c_2 and c_3 . In the above formula, **X** represents independent variables PE and R. **y** represents the dependent variable λ_{final}^R . *fun* represents the formula (4.1). **beta0** is a vector containing initial values

for the coefficients for c_1 , c_2 and c_3 . To avoid the ill condition in the nonlinear regression process, discard those encoding bit rate and perceptual entropy pairs where 75% of the tested λ_{final}^R values generated from the bisection method fall outside the range of $\pm 20\%$ of standard deviation from the mean value.

[0074] For 44.1 khz sampling audio, LAME's psychoacoustic model, the following values for c_1 , c_2 and c_3 to encode the audio file in MP3 format were obtained:

$$\begin{cases} c_1 = 8.3839 \\ c_2 = 1.3946 \\ c_3 = 6.2698 \end{cases}$$

[0075] The average number of iterations was tested over the Lagrangian multiplier if the formula (4.1) with the above estimated coefficient is used as the initial point for the bisection search. The average number of iterations over the Lagrangian multiplier is 1.5. On the other hand, the average number of iterations over the Lagrangian multiplier ranges from 4 to 8 if an arbitrary number is used as the initial point. Therefore, on the average, using (4.1) as the initial point can run 4 times as fast as the method in which an arbitrary initial point is used.

[0076] Implementation and simulation results of the optimization process 50 will now be described, referring now to Figures 6 to 9. Generally, the performance of example embodiments is implemented based on two MP3 encoders: ISO reference codec and LAME 3.96.1. For each case, the iterative optimization algorithm uses the original encoder output as the initial points. Figure 6 shows a graph 140 of performance characteristics of an example embodiment, showing a comparison of the method 50 (Figure 20) for encoding of audio file waltz.wav as compared to ISO reference codec. Figure 7 shows a graph 150 of performance characteristics of an example embodiment, for encoding of audio file waltz.wav as compared to LAME. Figure 8 shows a graph 160 of performance characteristics of an example embodiment, for encoding of audio file violin.wav as compared to ISO reference codec. Figure 9 shows a graph 170 of performance characteristics of an example embodiment, for encoding of audio file violin.wav as compared to LAME.

[0077] The LAME MP3 encoder features a psychoacoustic model, joint stereo encoding and variable bit-rate encoding. However, LAME still uses the basic structure of typical TNLS. In LAME 3.96.1, a refining TNLS is used to minimize the total noise to masking ratio for an entire frame after the successful termination of search process given its typical TNLS. Specifically, during each outer loop, the band with maximum noise to masking ratio is amplified and the best result based on total noise to mask ratio is stored.

[0078] The method 50 (Figure 2) is implemented as described above. For each case, the perceptual model, joint stereo encoding mode and window switching decision are kept intact. Figure 6 shows the rate-distortion performance of the method 50 (Figure 2) (denoted as "RD optimization" in the graph 140) applied to ISO reference encoder, when compared to a conventional or normal ISO reference encoder implementing TNLS, in constant bit-rate mode for waltz.wav. The test file may for example be encoded at 48khz, 2 channel, 16 bits/sample, 30 seconds. In Figure 6, "ISO-HO" represents the optimal Huffman tables used for Huffman coding, while "ISO-NH" means that the first Huffman table satisfying the coding limit is selected for each Huffman coding region. The vertical axes denote the average noise to mask ratio over all audio frames. From Figure 6, the method 50 (Figure 2) can achieve significant performance gain over the ISO reference encoder. For instance, at 320kbps the proposed optimization algorithm achieves 4.57dB and 2.75dB ANMR gains over ISO-NH and ISO-HO respectively. The ANMR of the optimized algorithm at 32kbps is similar to that of ISO reference encoder at 40kbps, which corresponds to equivalent 20% compression rate reduction.

[0079] Figure 7 depicts the rate-distortion performance of the method 50 (Figure 2) (also denoted as "RD optimization") applied to LAME when compared to the LAME reference encoder (implementing conventional TNLS) in constant bit-rate mode for waltz.wav. It is shown separately from ISO reference encoder because ISO reference encoder and LAME adopt different perceptual models. For an unbiased comparison, in some example embodiments the LAME encoder disables the functions of amplitude scaling and low pass filter. In Figure 7, "LAME" means that the audio file is compressed using LAME's normal compression mode. As shown, the method 50 (Figure 2) outperforms LAME in terms of compression performance. At 96kbps, the proposed optimization algorithm achieves about 1.34dB ANMR gain over LAME.

[0080] Figures 8 and 9 compare the compression performance of the method 50 (Figure 2) for the music file violin.wav (MPEG lossless audio coding test file, 48khz, 2 channel, 16 bits/sample, 30 seconds) in constant bit-rate mode. Figure 8 shows results from ISO reference encoder, while Figure 9 shows results from LAME. It may be observed that "RD optimization" has improved rate-distortion over the conventional reference encoders. Similar results may be observed for other test music files.

[0081] Referring now to Figure 2, the computational complexity of the method 50 will now be described. Given the value of λ , the number of iterations in the iterative joint optimization algorithm has a direct impact on the computational complexity. Experiments show that by setting the convergence tolerance ϵ to 0.005, the iteration process is observed to converge after 2 loops in most cases, that is, most of the gain achievable from full joint optimization is obtained within two iterations. This is the same to the iterative quantization factor q updating in step 58. In Step 56, the search range for y_j is set to $[yh_j - a, yh_j + a]$, where yh_j is the j th quantized coefficient from hard decision quantization (e.g. y_j is determined from (2.1)) and a is a fixed integer. Experiments show that further expansion of the search range for y_j beyond $a = 2$ does not significantly improve compression performance. In constant bit-rate mode, the average number of iterations over the Lagrangian multiplier is 1.5 if the formula (4.1) is used as the initial point. On the other hand, the average number of iterations over the Lagrangian multiplier ranges from 4 to 8 if an arbitrary number is used as the initial point.

[0082] Table 3 lists the computation time (in seconds) on a Pentium PC, 2.16GHZ, 1G by tes of RAM to encode violin.wav and waltz.wav at different transmission rates for the method 50 based on LAME reference codec.

[0083]

Table 3. Computation time in seconds for different MP3 encoders

Bit rates (kbps)	96	112	128	160	192
Waltz.wav	27	23	21	21	16
Violin.wav	23	22	20	16	15

[0084] From Table 3 the proposed optimization algorithm generally reaches real time throughput, which suggests that the method 50 is computationally efficient. As shown in Table 3, the computation time is generally less than 30 seconds. The computation time for ISO-based encoders is not listed, but are generally less-efficient than LAME-based encoders in both the computation time and compression performance.

[0085] Reference is now made to Figure 10, which shows an encoder 300 in accordance with an example embodiment. The encoder 300 may for example be implemented on a suitable configured computer device. The encoder 300 includes a controller such as a microprocessor 304 that controls the overall operation of the encoder 300. The microprocessor 304 may also interact with other subsystems (not shown) such as a communications subsystem, display, and one or more auxiliary input/output (I/O) subsystems or devices. The encoder 300 includes a memory 304 accessible by the microprocessor 304. Operating system software 306 and various software applications 308 used by the microprocessor 302 are, in some example embodiments, stored in memory 304 or similar storage element. For example, MP3 software application 310, such as the ISO-based encoder or LAME-based encoder described above, may be installed as one of the various software applications 308. The microprocessor 302, in addition to its operating system functions, in example embodiments enables execution of software applications 308 on the device.

[0086] The encoder 300 may be used for optimizing performance of MP3 encoding of a source sequence. Specifically, the encoder 300 may enable the microprocessor 304 to determine quantization factors (for example including a global quantization step size and scale factors) for the source sequence. The memory 304 may contain a cost function of an encoding of the source sequence, wherein the cost function is dependent on the quantization factors. The memory 304 may also contain a predetermined tolerance of the cost function stored in the memory 304. Instructions residing in memory 304 enable the microprocessor 203 to access the cost function and predetermined tolerance from memory 304, determine the quantization factors which minimize the cost function within the predetermined tolerance, and store the determined quantization factors in memory 304 for MP3 encoding of the source sequence. Generally, an iterative method is performed such that *global_gain* is determined while the scale factors are fixed, and the scale factors are determined while *global_gain* is fixed. This is repeated until a calculated rate-distortion cost is within a predetermined threshold. For example, the MP3 software application 310 may be used to perform MP3 encoding using the determined quantization factors.

[0087] In another example embodiment, the encoder 300 may be configured for optimizing of parameters including quantization factors, in a manner similar to the example methods described above. For example, the encoder 300 may be configured to perform the method 50 (Figure 2).

[0088] While the foregoing has been described with respect to MP3 encoding, it may be appreciated by those skilled in the art that example embodiments may be adapted to or implemented by other forms of signal encoding or audio signal encoding, for example Advanced Audio Coding.

[0089] While example embodiments have been described in detail in the foregoing specification, it will be understood by those skilled in the art that variations may be made without departing from the scope of the present application.

Claims

1. A method for optimizing audio encoding of a source sequence, the encoding being dependent on quantization factors, the quantization factors including a global quantization step size and scale factors, the method comprising:

5 defining a cost function of the encoding of the source sequence, the cost function being dependent on the quantization factors;
 initializing fixed values of the scale factors; and
 10 determining values of the quantization factors which minimize the cost function by iteratively performing:

determining, for the fixed values of the scale factors, a value of the global quantization step size which minimizes the cost function,
 fixing the determined value of the global quantization step size and determining values of scale factors which minimize the cost function, and fixing the determined values of the scale factors, and
 15 determining whether the cost function is below a predetermined threshold, and if so ending the iteratively performing.

2. The method claimed in claim 1, wherein the cost function is based on a distortion of the encoding of the source sequence and further based on a tradeoff function that represents a tradeoff of a rate for distortion, said rate being a transmission bit rate of the encoding of the source sequence.

3. The method claimed in claim 2, wherein, in the step of fixing the determined value of the global quantization step size and determining values of scale factors which minimize the cost function, the distortion is obtained from a pre-generated table.

4. The method claimed in claim 2, wherein the tradeoff function includes λ , the method further comprising:

calculating λ as:

$$\lambda_{final}^R = \frac{c_1 \ln 10}{10M} \times 10^{(c_2 PE - c_3 R)/M}$$

35 wherein PE is Perceptual Entropy of an encoded frame, R is the rate, M is a number of audio samples to be encoded, and c_1 , c_2 and c_3 are constants; and calculating the cost function using λ .

5. The method claimed in claim 1, wherein the determining of the value of global quantization step size includes calculating:

$$\frac{4}{\log_{10} 2} \log_{10} \frac{\sum_{sb=1}^N b[sb]}{\sum_{sb=1}^N a[sb]} + 210$$

50 wherein

$$b[sb] = 2^{-scale_factor[sb]/4} \cdot w[sb] \cdot \sum_{i=[sb]}^{l[sb+1]-1} x r_i \cdot y_i^{4/3}$$

and

5

$$a[sb] = 2^{-scale_factor[sb]/2} \cdot w[sb] \cdot \sum_{i=[sb]}^{[sb+1]-1} y_i^{4/3}$$

10

wherein xr_i is the source sequence, $scale_factor[sb]$ is a quantization step size for scale factor band sb , $[sb]$ and $[sb+1]-1$ are start and end positions for scale factor band sb respectively, $w[sb]$ is an inverse of the masking threshold for scale factor band sb , and y_i is a quantized spectral coefficient of the source sequence.

15

6. The method claimed in claim 1, further comprising constraining the scale factors to within a bit length.
7. The method claimed in claim 10, wherein the bit length is a first bit length for a first group of scale factor bands and the bit length is a second bit length for a second group of scale factor bands.

20

8. The method claimed in claim 1, wherein the scale factors include a parameter $scalefac$ being a scale factor for a particular scale factor band, the method further comprising constraining $scalefac$ to within a bit length.

25

9. The method claimed in claim 8, wherein the bit length is a first bit length for a first group of scale factor bands and the bit length is a second bit length for a second group of scale factor bands.

30

10. The method claimed in claim 1, wherein the scale factors include a parameter $scalefac$ being a scale factor for a particular scale factor band, the method further comprising:

calculating a value of $scalefac$ which minimizes the cost function; and
determining whether the calculated value of $scalefac$ exceeds encoding within a bit length, and if so constraining $scalefac$ to within the bit length.

35

11. The method claimed in claim 10, wherein the step of calculating the value of $scalefac$ includes calculating:

$$\frac{4}{\log_{10} 2} \log_{10} \frac{\sum_{i=[sb]}^{[sb+1]-1} xr_i \cdot y_i^{4/3}}{\sum_{i=[sb]}^{[sb+1]-1} y_i^{8/3}}$$

40

wherein xr_i is the source sequence, $[sb]$ and $[sb+1]-1$ are start and end positions for scale factor band sb respectively and y_i is a quantized spectral coefficient of the source sequence.

45

12. The method claimed in claim 14, further comprising:

calculating the cost function for $scalefac = 0$ for a scale factor band; and
storing in a memory the calculated cost function for $scalefac = 0$ for subsequent retrieval.

50

13. The method claimed in claim 1, wherein the audio encoding is MPEG I/II Layer-3 encoding.

55

14. The method claimed in claim 1, wherein the encoding is further dependent on quantized spectral coefficients, Huffman codebooks, and Huffman coding region partition, the method further including minimizing the cost function with respect to the quantized spectral coefficients, the Huffman codebooks, and the Huffman coding region partition.

15. An encoder for optimizing audio encoding of a source sequence, the audio encoding being dependent on quantization factors, the quantization factors including a global quantization step size and scale factors, the encoder comprising:

EP 2 192 577 A1

a controller;

a memory accessible by the controller, a cost function of the encoding of the source sequence stored in memory, the cost function being dependent on the quantization factors; and a predetermined threshold of the cost function stored in the memory,

5 wherein the controller is configured to:

access the cost function and predetermined threshold from memory,

initialize fixed values of the scale factors, and

10 determine values of the quantization factors which minimize the cost function by iteratively performing:

determining, for the fixed values of the scale factors, a value of the global quantization step size which minimizes the cost function,

fixing the determined value of the global quantization step size and determining values of scale factors which minimize the cost function, and fixing the determined values of the scale factors, and

15 determining whether the cost function is below the predetermined threshold, and if so ending the iteratively performing.

20

25

30

35

40

45

50

55

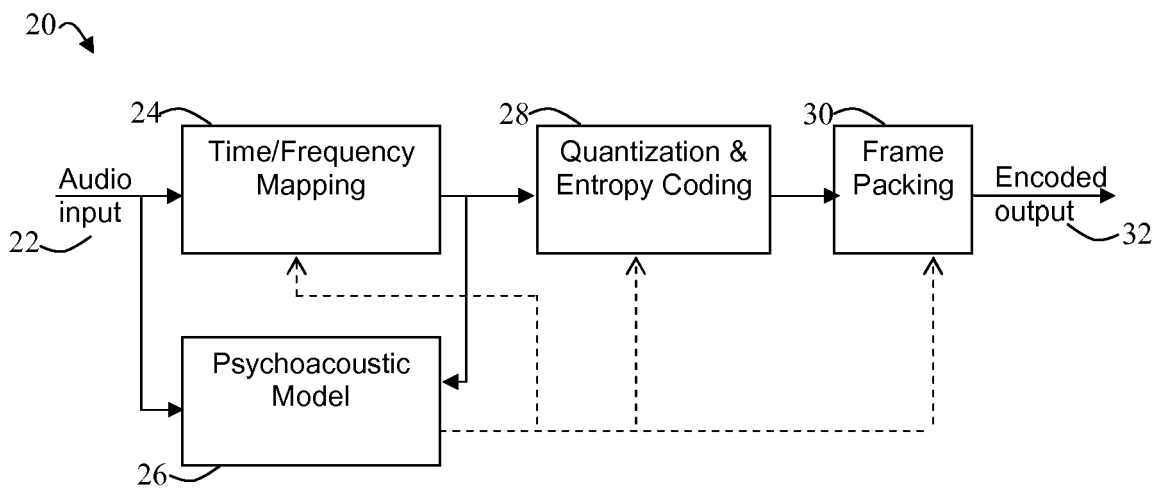

FIG. 1

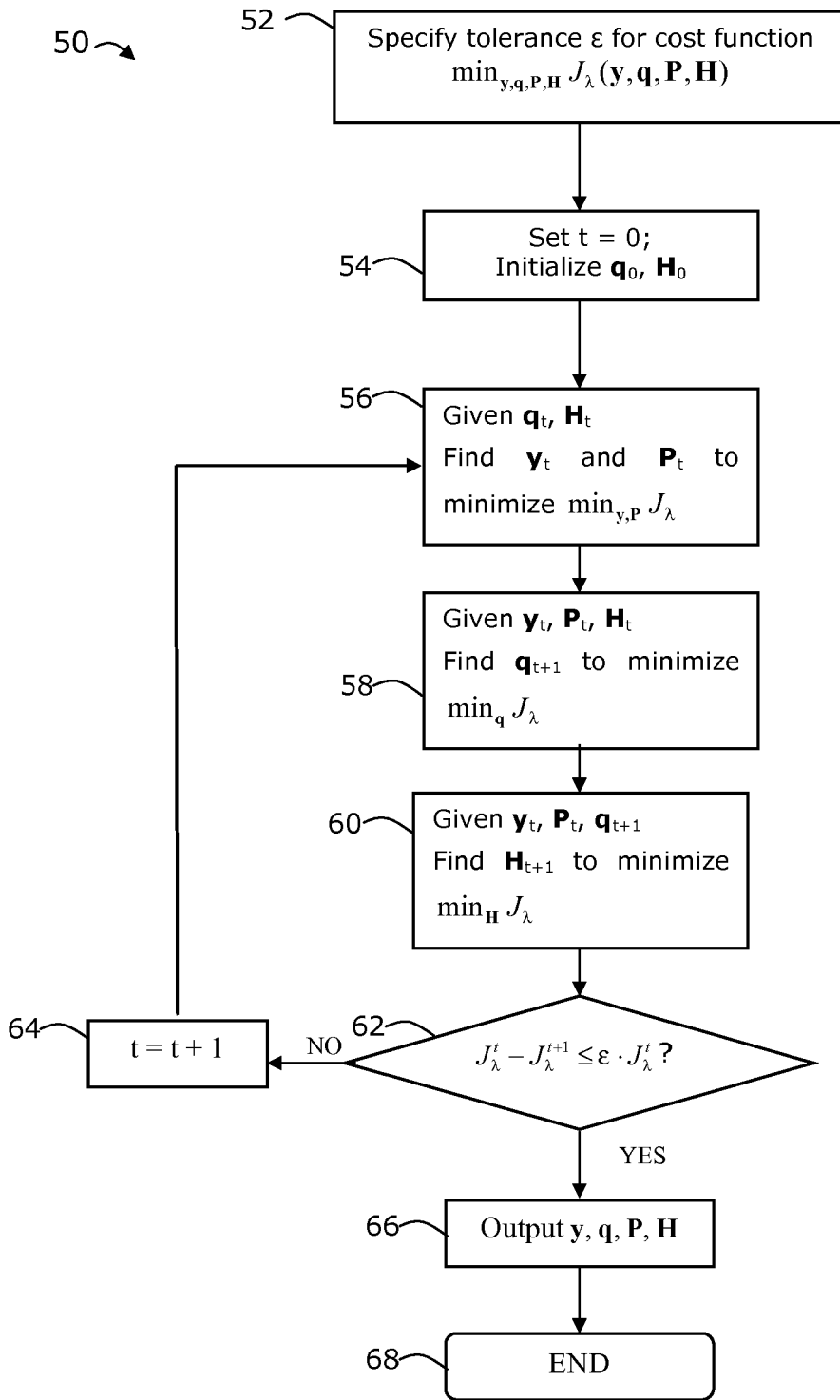

FIG. 2

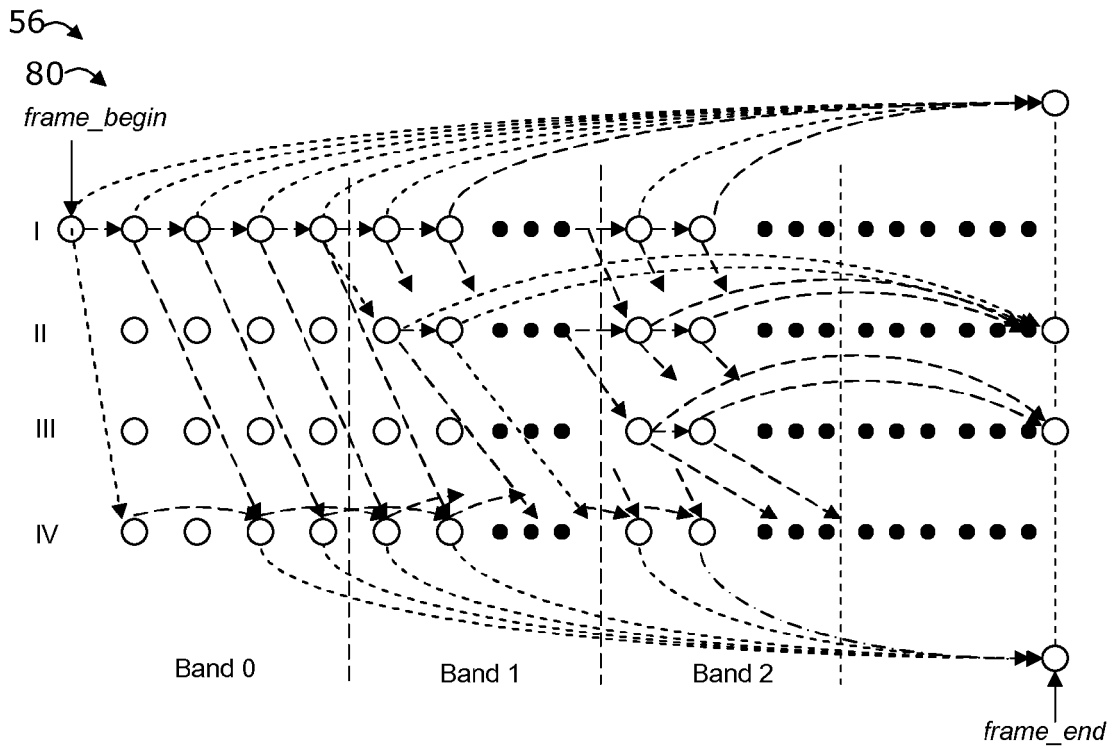

FIG. 3

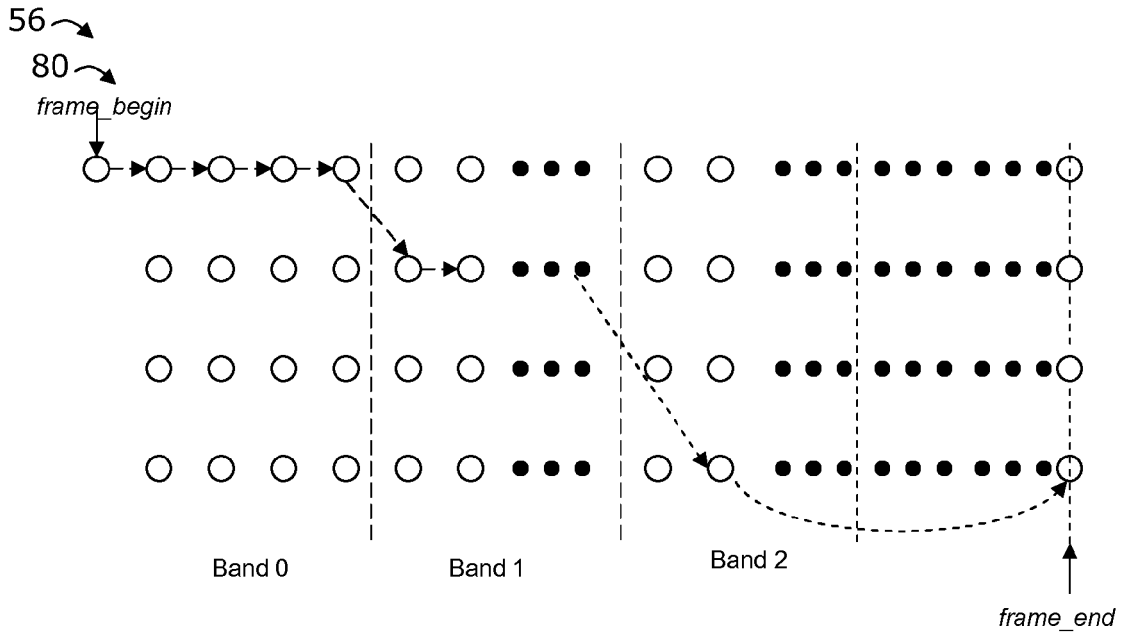

FIG. 4

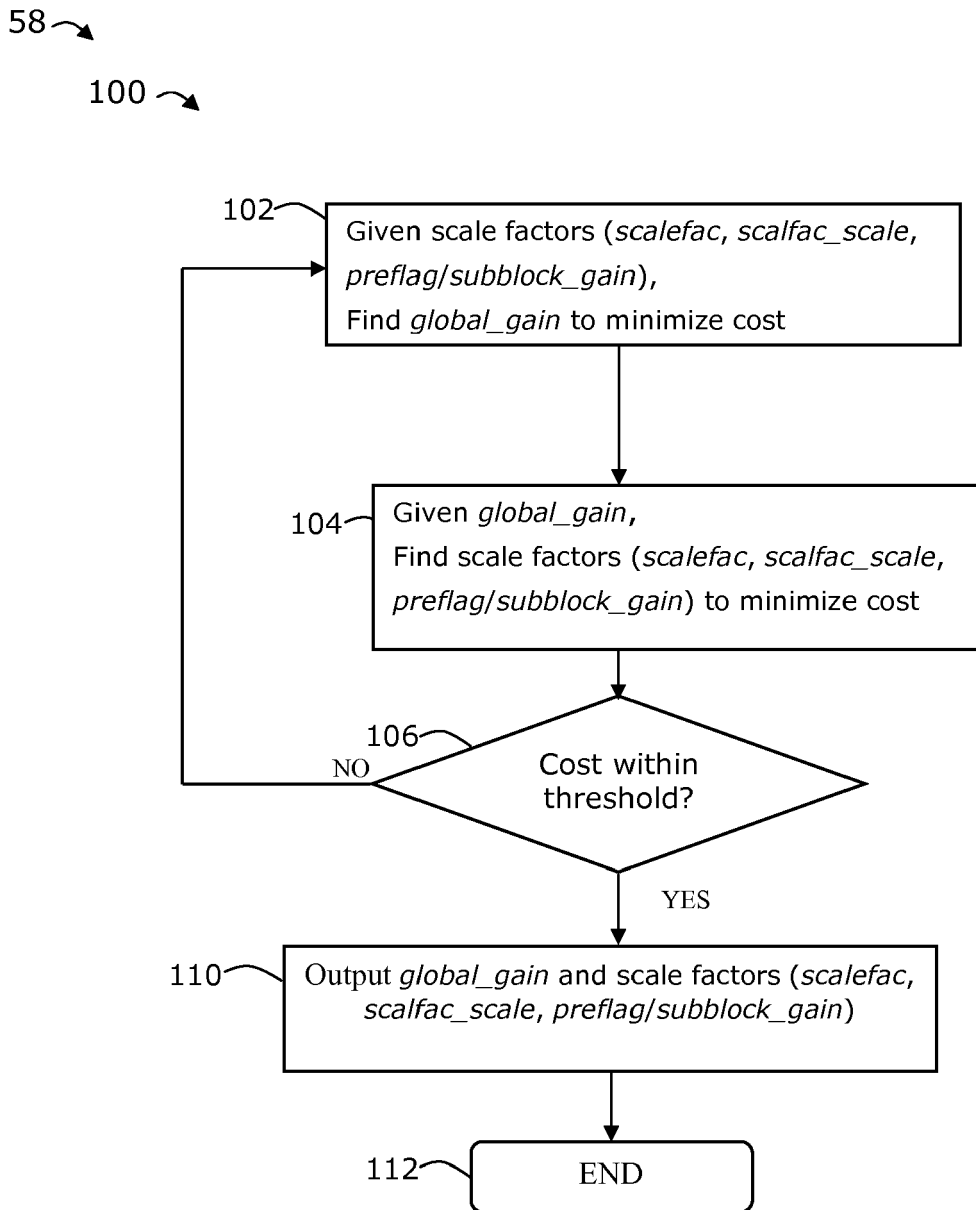

FIG. 5

140 ↷

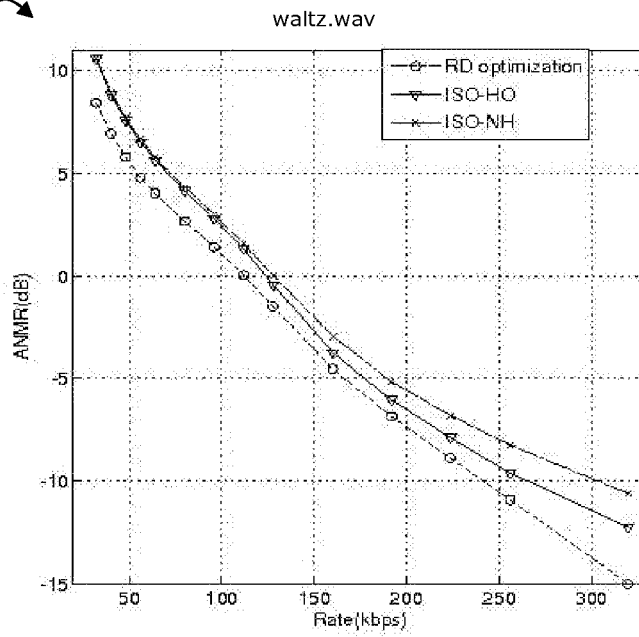

FIG. 6

150 ↷

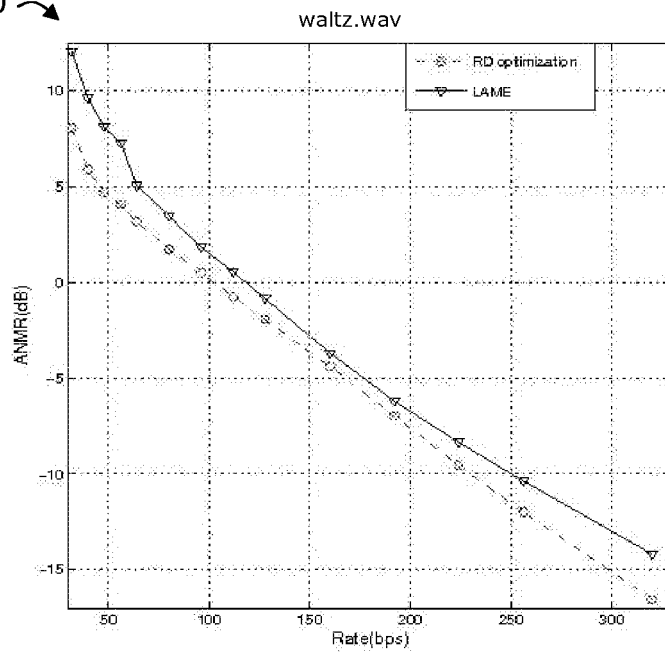

FIG. 7

160 ↷

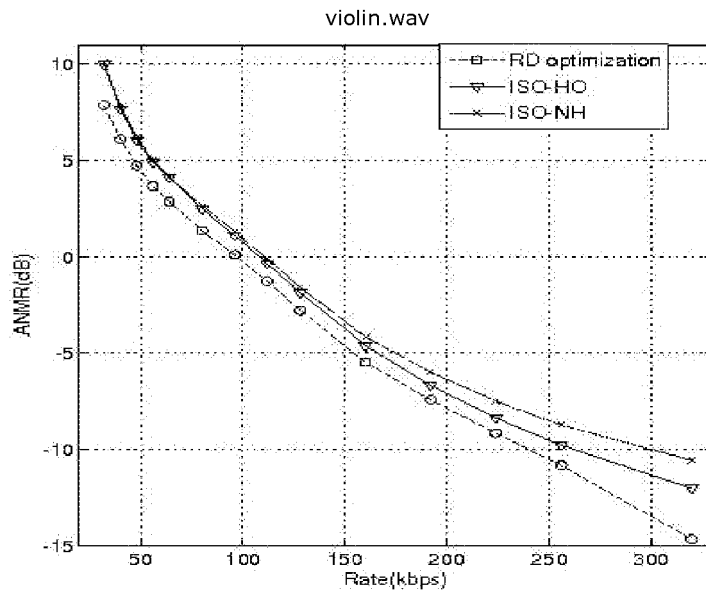

FIG. 8

170 ↷

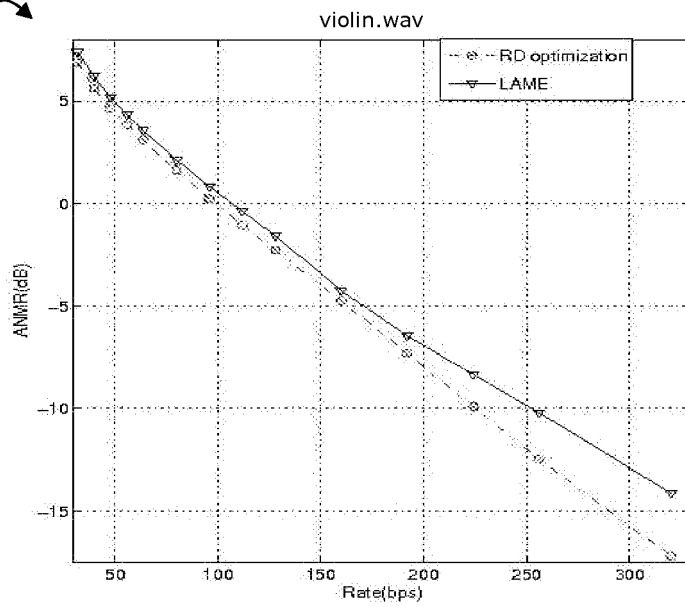

FIG. 9

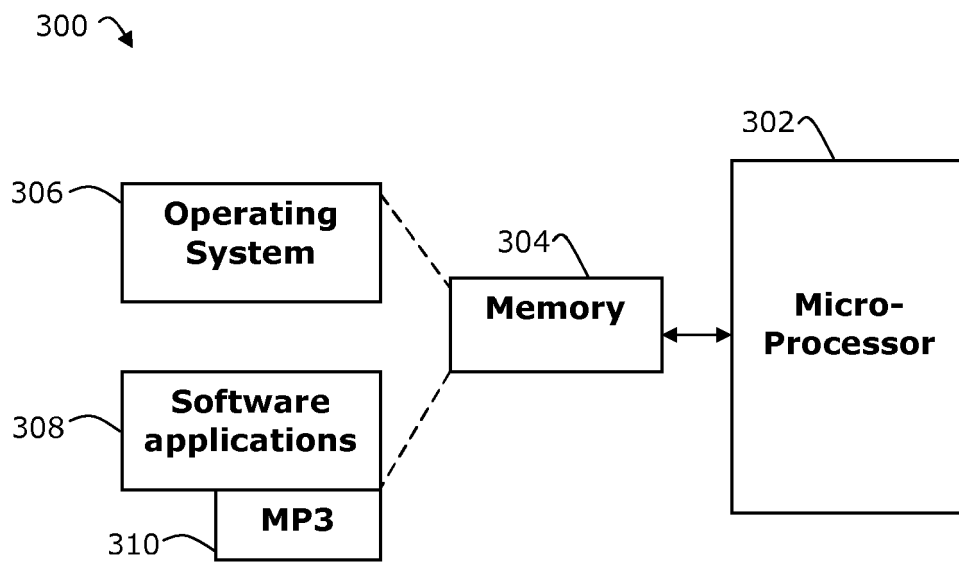

FIG. 10



EUROPEAN SEARCH REPORT

Application Number
EP 08 17 0396

DOCUMENTS CONSIDERED TO BE RELEVANT			
Category	Citation of document with indication, where appropriate, of relevant passages	Relevant to claim	CLASSIFICATION OF THE APPLICATION (IPC)
A	BOSI M ET AL: "ISO/IEC MPEG-2 ADVANCED AUDIO CODING" JOURNAL OF THE AUDIO ENGINEERING SOCIETY, AUDIO ENGINEERING SOCIETY, NEW YORK, NY, US, vol. 45, no. 10, 1 October 1997 (1997-10-01), pages 789-812, XP000730161 ISSN: 1549-4950 * paragraph [05.4] - paragraph [5.5.2]; figures 10,11 *	1-15	INV. G10L19/02
D,A	JINGMING XU ET AL: "Rate-distortion Optimization for MP3 Audio Coding with Complete Decoder Compatibility" MULTIMEDIA SIGNAL PROCESSING, 2005 IEEE 7TH WORKSHOP ON, IEEE, PI, 1 October 2005 (2005-10-01), pages 1-4, XP031018284 ISBN: 978-0-7803-9288-5 * abstract * * paragraph [III.] *	1-15	
A	EP 1 850 327 A (ST MICROELECTRONICS ASIA [SG]) 31 October 2007 (2007-10-31) * abstract; figure 5 * * paragraph [0048] - paragraph [0049] *	1-15	
The present search report has been drawn up for all claims			TECHNICAL FIELDS SEARCHED (IPC)
			G10L
1	Place of search Munich	Date of completion of the search 30 April 2009	Examiner Zimmermann, Elko
CATEGORY OF CITED DOCUMENTS X : particularly relevant if taken alone Y : particularly relevant if combined with another document of the same category A : technological background O : non-written disclosure P : intermediate document		T : theory or principle underlying the invention E : earlier patent document, but published on, or after the filing date D : document cited in the application L : document cited for other reasons & : member of the same patent family, corresponding document	

EPO FORM 1503 03.02 (F04C01)

**ANNEX TO THE EUROPEAN SEARCH REPORT
ON EUROPEAN PATENT APPLICATION NO.**

EP 08 17 0396

This annex lists the patent family members relating to the patent documents cited in the above-mentioned European search report. The members are as contained in the European Patent Office EDP file on
The European Patent Office is in no way liable for these particulars which are merely given for the purpose of information.

30-04-2009

Patent document cited in search report	Publication date	Patent family member(s)	Publication date
EP 1850327 A	31-10-2007	CN 101064106 A	31-10-2007
		SG 136836 A1	29-11-2007
		US 2007255562 A1	01-11-2007

EPO FORM P0459

For more details about this annex : see Official Journal of the European Patent Office, No. 12/82

REFERENCES CITED IN THE DESCRIPTION

This list of references cited by the applicant is for the reader's convenience only. It does not form part of the European patent document. Even though great care has been taken in compiling the references, errors or omissions cannot be excluded and the EPO disclaims all liability in this regard.

Non-patent literature cited in the description

- **Xu ; E.-h. Yang.** Rate-distortion optimization for MP3 audio coding with complete decoder compatibility. *Proc. 2005 IEEE Workshop on Multimedia Signal Processing*, October 2005 [0036]
- **C. Bauer ; M. Vinton.** Joint optimization of scale factors and Huffman codebooks for MPEG-4 AAC. *Proc. of the 2004 IEEE workshop on Multimedia Signal Processing*, 2004, 111-114 [0071]
- **C. Bauer ; M. Vinton.** Joint optimization of scale factors and Huffman codebooks for MPEG-4 AAC. *IEEE Trans. on Signal Processing*, January 2006, vol. 54, 177-189 [0071]