



US00RE49198E

(19) **United States**
(12) **Reissued Patent**
Coenegracht

(10) **Patent Number:** **US RE49,198 E**
(45) **Date of Reissued Patent:** ***Sep. 6, 2022**

(54) **FIBER OPTIC CONNECTION SYSTEM**
(71) Applicant: **CommScope Connectivity Belgium BVBA**, Kessel-Lo (BE)
(72) Inventor: **Philippe Coenegracht**, Hasselt (BE)
(73) Assignee: **COMMSCOPE CONNECTIVITY BELGIUM BVBA**, Kessel-Lo (BE)

(*) Notice: This patent is subject to a terminal disclaimer.

(21) Appl. No.: **17/012,859**

(22) Filed: **Sep. 4, 2020**

Related U.S. Patent Documents

Reissue of:

(64) Patent No.: **10,422,962**
Issued: **Sep. 24, 2019**
Appl. No.: **16/018,895**
Filed: **Jun. 26, 2018**

U.S. Applications:

(63) Continuation of application No. 17/003,664, filed on Aug. 26, 2020, which is an application for the reissue of Pat. No. 10,422,962, which is a continuation of application No. 15/300,147, filed as application No. PCT/EP2015/056720 on Mar. 27, 2015, now Pat. No. 10,061,090.

(60) Provisional application No. 61/971,739, filed on Mar. 28, 2014.

(51) **Int. Cl.**
G02B 6/38 (2006.01)

(52) **U.S. Cl.**
CPC **G02B 6/3817** (2013.01); **G02B 6/389** (2013.01); **G02B 6/3825** (2013.01); **G02B 6/3826** (2013.01); **G02B 6/3831** (2013.01); **G02B 6/3878** (2013.01); **G02B 6/3887** (2013.01)

(58) **Field of Classification Search**
CPC .. G02B 6/3817; G02B 6/3825; G02B 6/3826; G02B 6/3831; G02B 6/3878; G02B 6/3887; G02B 6/389
See application file for complete search history.

(56) **References Cited**

U.S. PATENT DOCUMENTS

4,741,590 A * 5/1988 Caron G02B 6/3825 385/60
4,846,719 A 7/1989 Iwashita
4,896,939 A 1/1990 O'Brien G02B 6/3816 174/110 R
5,109,452 A 4/1992 Selvin et al.
(Continued)

FOREIGN PATENT DOCUMENTS

EP 1006380 A1 * 6/2000 G02B 6/3817
EP 1006619 A2 * 6/2000 G02B 6/3893
(Continued)

OTHER PUBLICATIONS

English translation of JP-S59075218-A retrieved from JPO's Japan Platform for Patent Information (J-PlatPat) website.*

(Continued)

Primary Examiner — Peter C English

(74) *Attorney, Agent, or Firm* — Merchant & Gould P.C.

(57) **ABSTRACT**

The present disclosure relates to a fiber optic connection system that uses a slide clip to provide robust retention of a fiber optic connector within a mating fiber optic adapter. In certain examples, the fiber optic connector may be a hybrid connector that provides both electrical and optical connectivity.

7 Claims, 23 Drawing Sheets

Amended

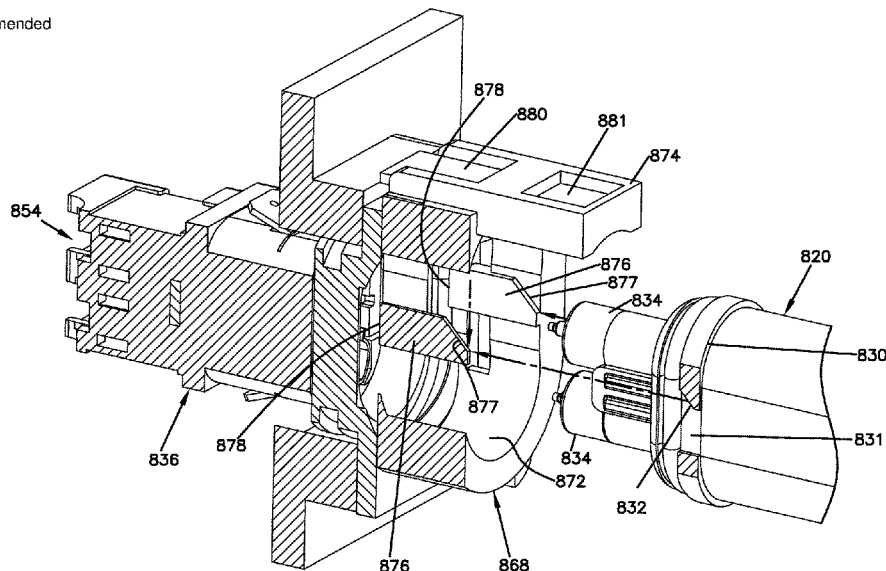

US RE49,198 E

Page 2

(56)

References Cited

U.S. PATENT DOCUMENTS

5,134,679 A 7/1992 Robin et al. G02B 6/3878
385/79
5,140,659 A 8/1992 Minds et al.
5,473,715 A 12/1995 Schofield et al.
5,971,625 A * 10/1999 Lu G02B 6/3893
385/55
6,357,931 B1 3/2002 Shirakawa et al.
6,588,938 B1 7/2003 Lampert et al.
8,475,055 B2 7/2013 Ciechomski et al.
8,480,312 B2 7/2013 Smith et al.
8,672,696 B2 3/2014 Sakurai
10,107,968 B2 * 10/2018 Tong G02B 6/3825
2001/0046354 A1 11/2001 Nguyen et al.
2005/0058402 A1 3/2005 Ernst et al.
2006/0093277 A1 5/2006 Mulligan
2006/0153503 A1 7/2006 Suzuki et al.
2006/0269194 A1 * 11/2006 Luther et al. G02B 6/3851
385/78
2008/0089650 A1 * 4/2008 Legler et al. G02B 6/389
385/59
2009/0148106 A1 * 6/2009 Moore et al. G02B 6/4281
385/89
2009/0175580 A1 7/2009 Chen et al. G02B 6/3817
385/75
2009/0220200 A1 * 9/2009 Wong et al. G02B 6/4292
385/89

2010/0061681 A1 * 3/2010 Powell G02B 6/3893
385/56
2011/0243508 A1 * 10/2011 Koreeda et al. G02B 6/3817
385/78
2011/0293223 A1 * 12/2011 Shimazu et al. H01R 4/18
385/81
2015/0219857 A1 * 8/2015 Lichoulas et al. ... G02B 6/3887
385/60
2015/0234127 A1 8/2015 Chen et al.
2018/0231728 A1 8/2018 Faw et al.

FOREIGN PATENT DOCUMENTS

EP 1 338 909 A2 8/2003
EP 1337883 B1 * 9/2004 G02B 6/3878
EP 2 381 282 A1 10/2011
GB 2344469 A * 6/2000 G02B 6/3817
JP 59075218 A * 4/1984 G02B 6/3878
JP 2005-099345 A 4/2005
JP 2006-284897 A 10/2006
JP 2010-156831 A 7/2010
WO 2015/120365 A1 8/2015

OTHER PUBLICATIONS

International Search Report and Written Opinion of the International Searching Authority for International Patent Application No. PCT/EP2015/056720 dated Jun. 16, 2015, 15 pgs.

* cited by examiner

FIG. 2

Amended

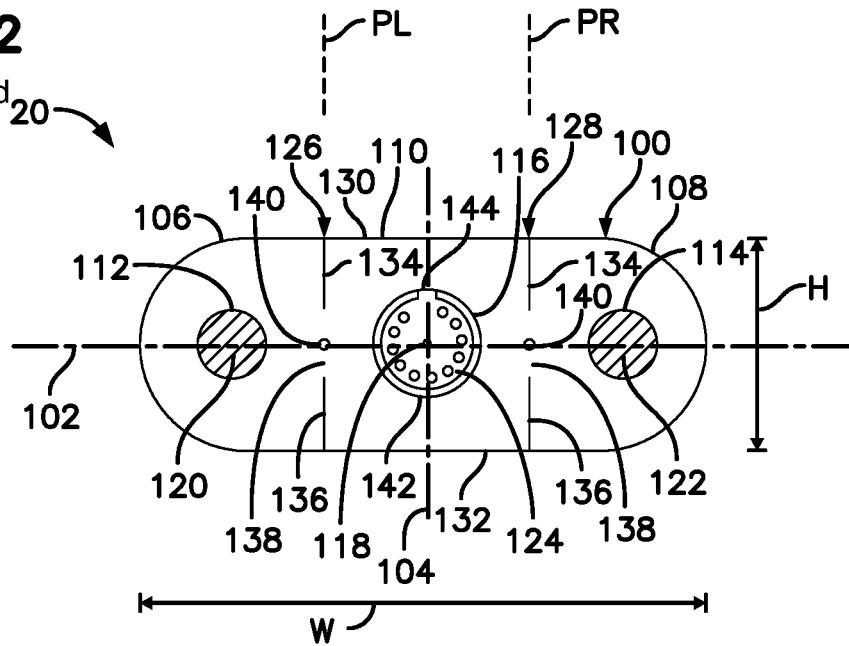

FIG. 3

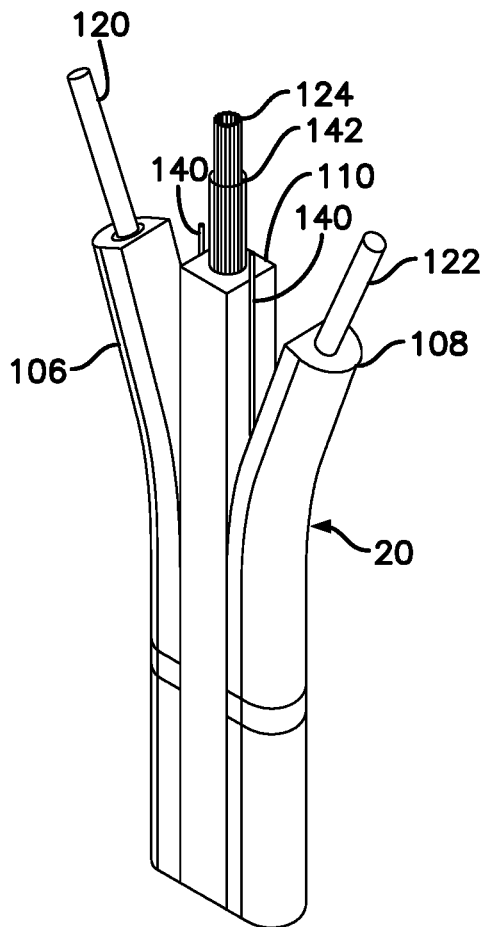

FIG. 4

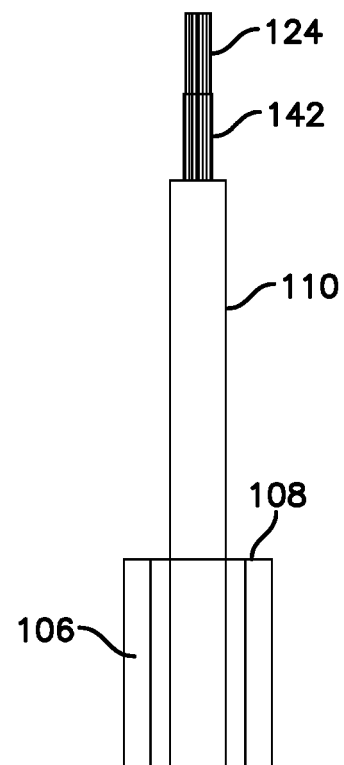
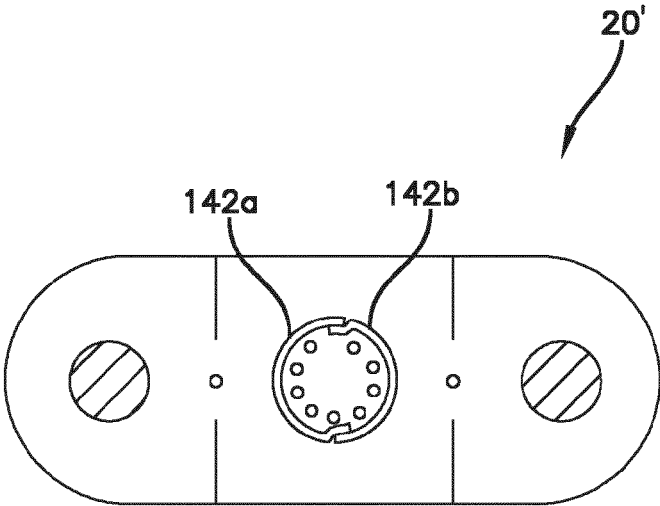

FIG. 5



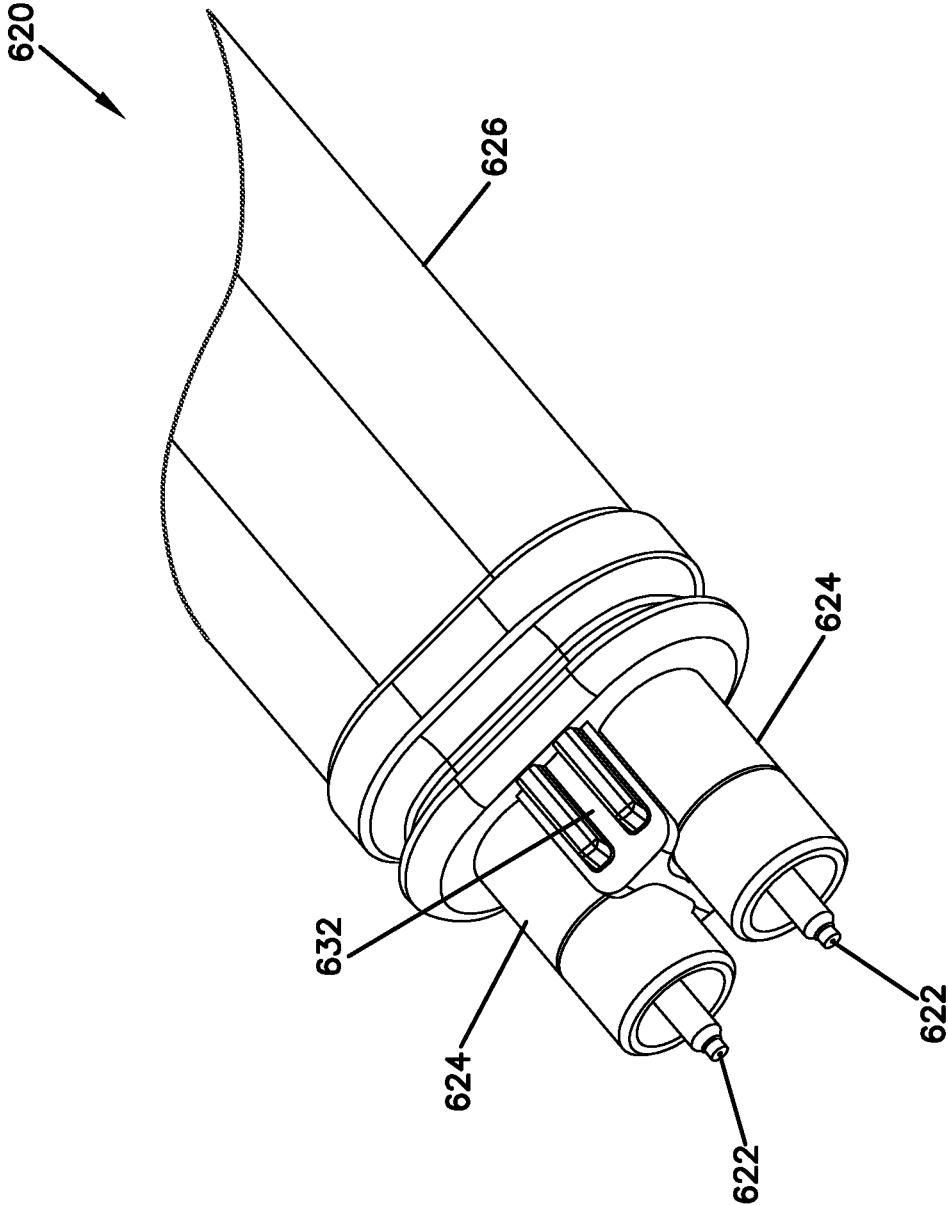

FIG. 6
Amended

FIG. 7

Amended

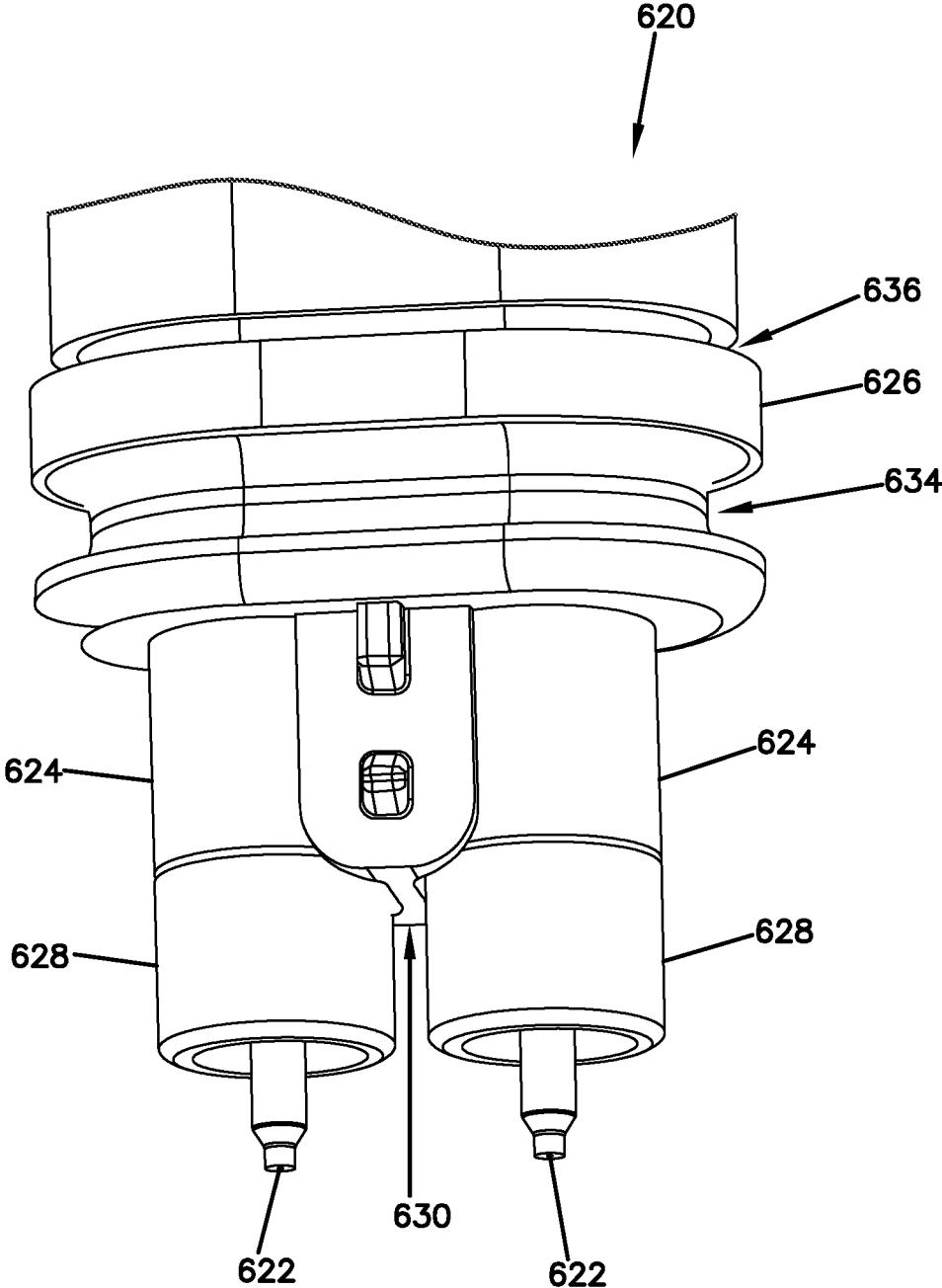

FIG. 8

Amended

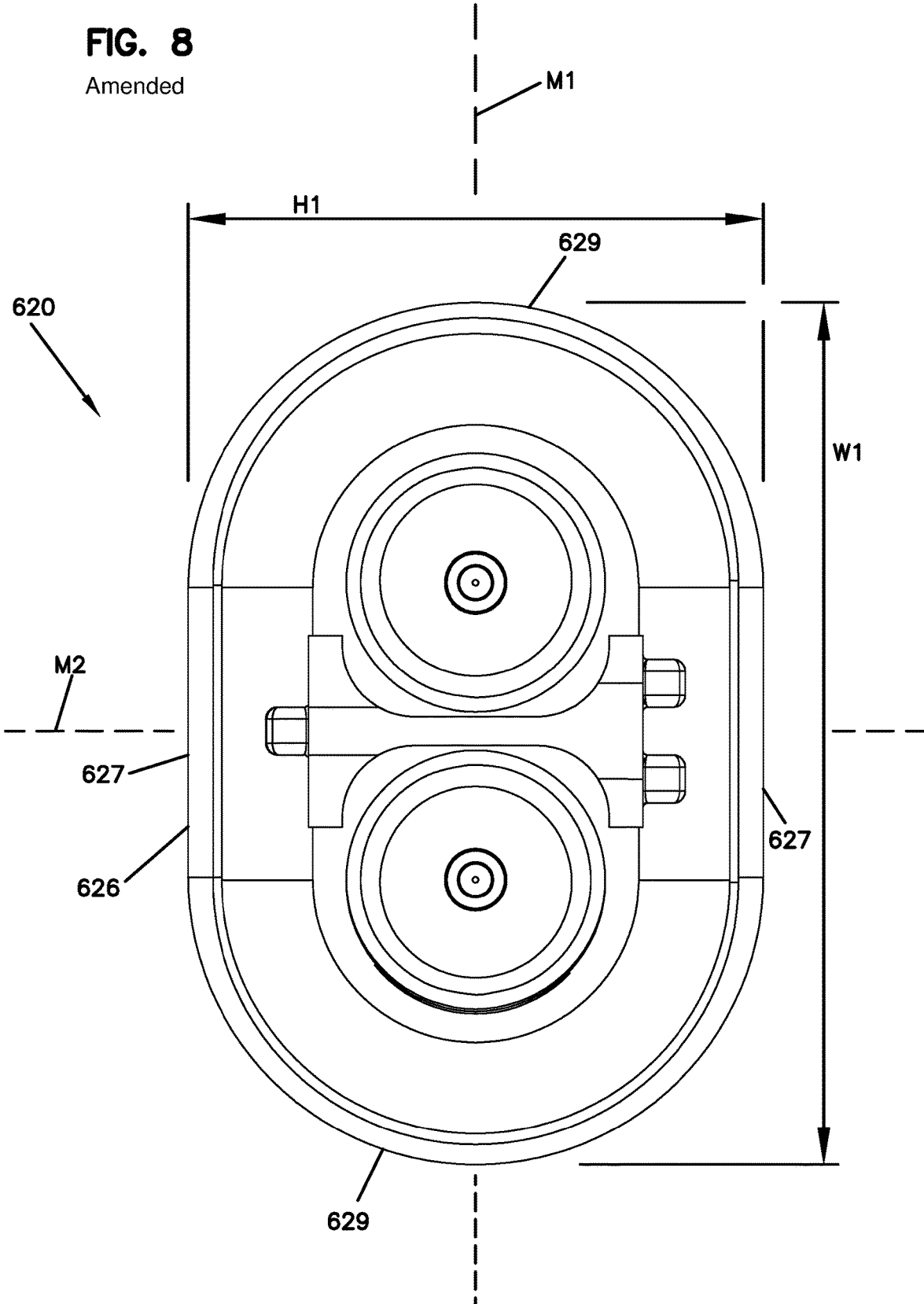

FIG. 9

Amended

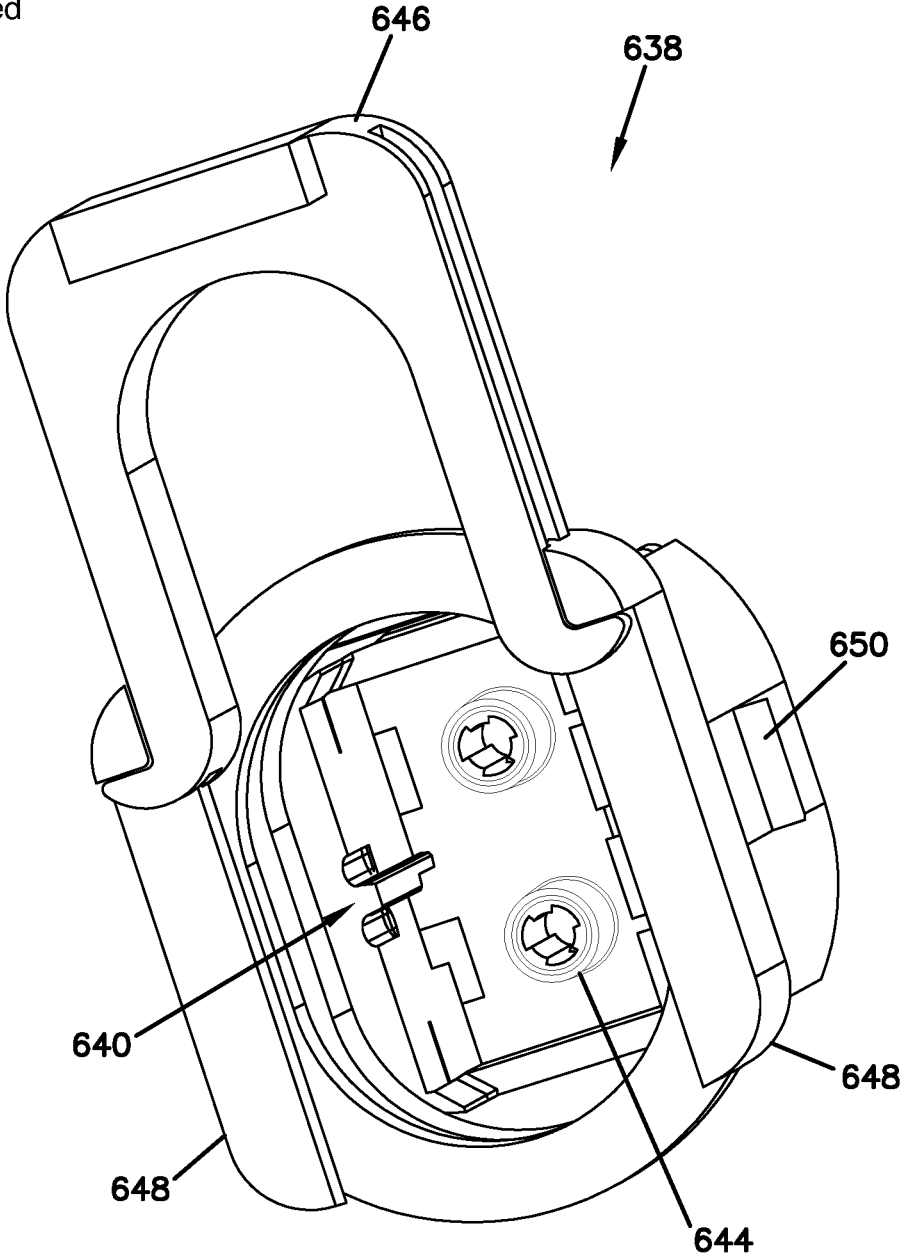

FIG. 10
Amended

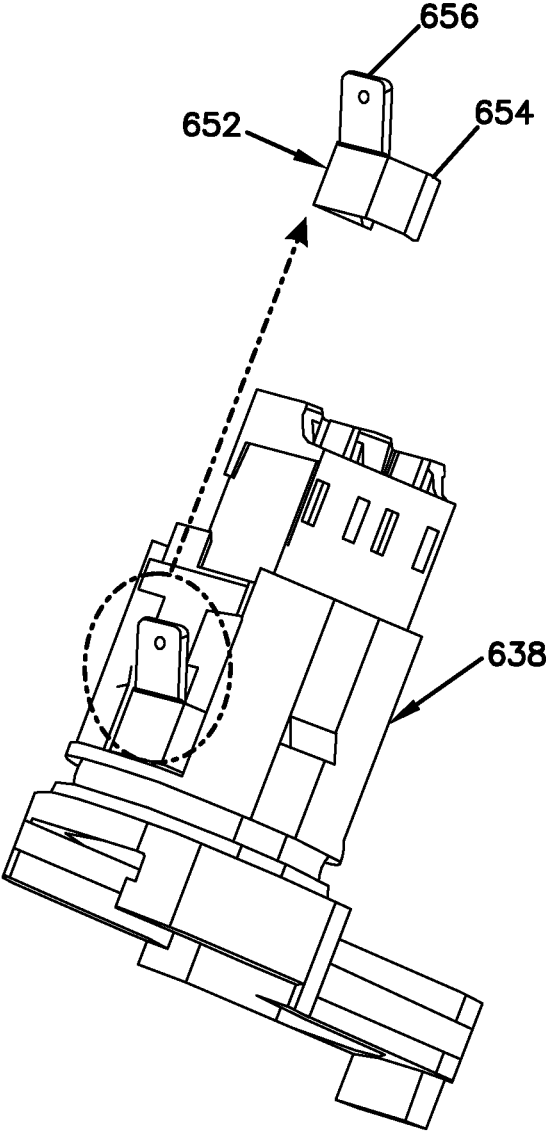

FIG. 11

Amended

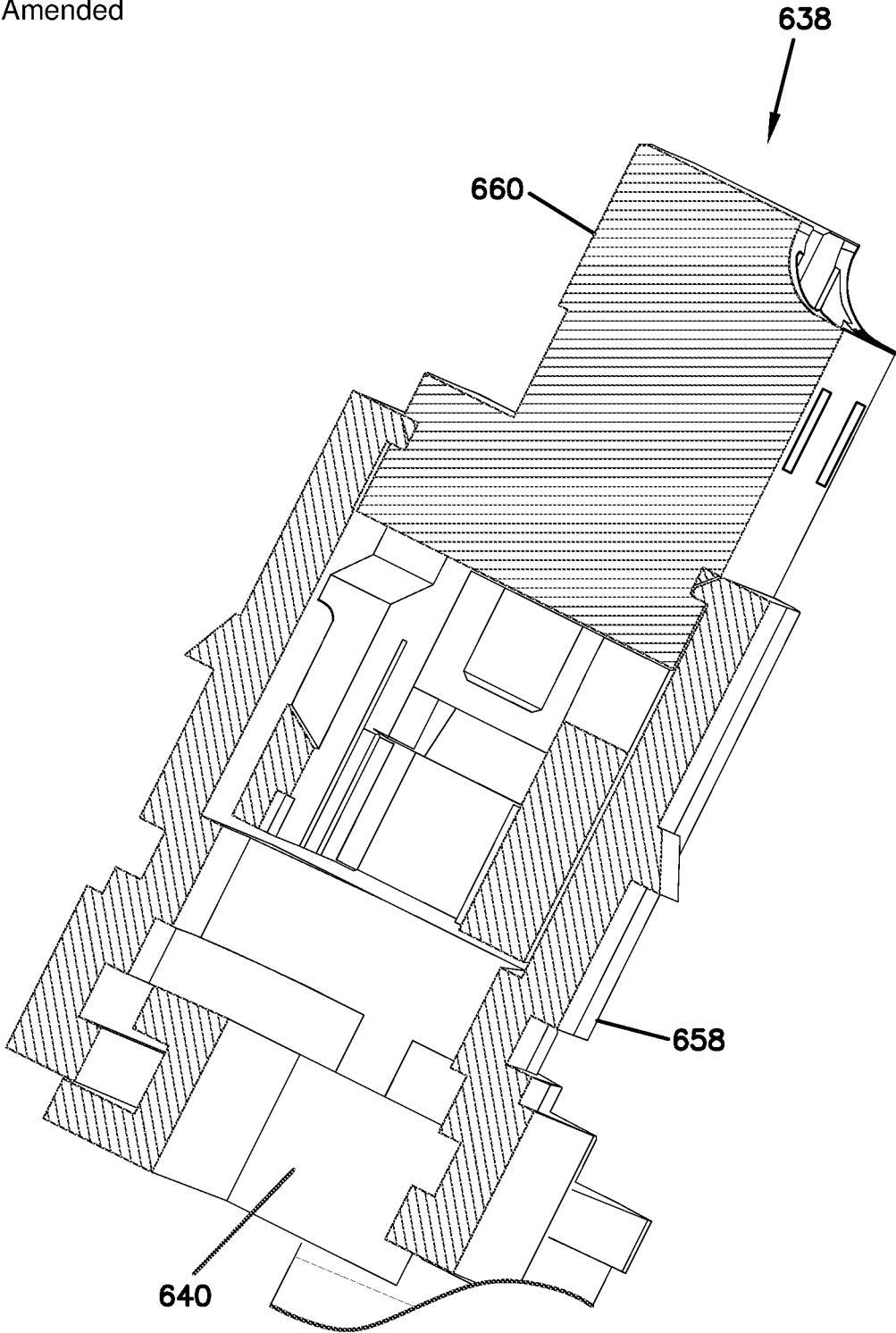
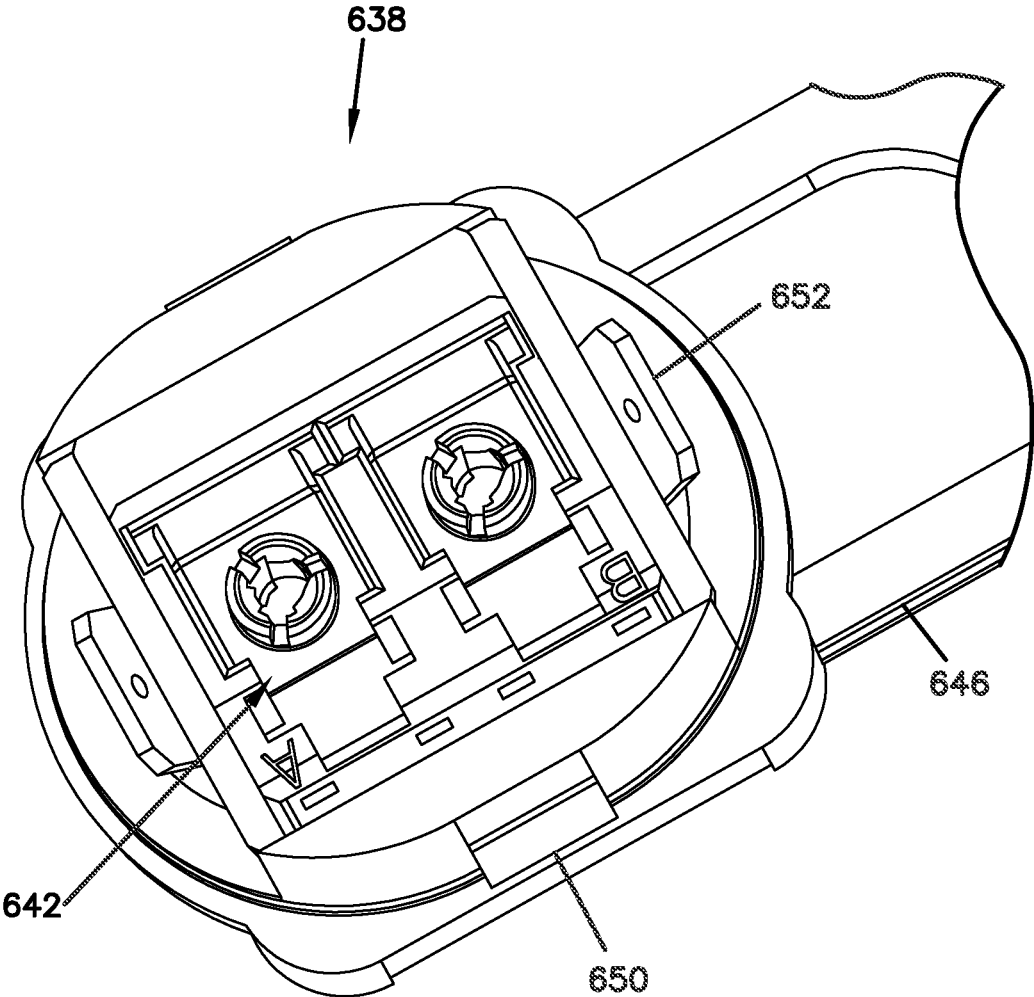

FIG. 12

Amended



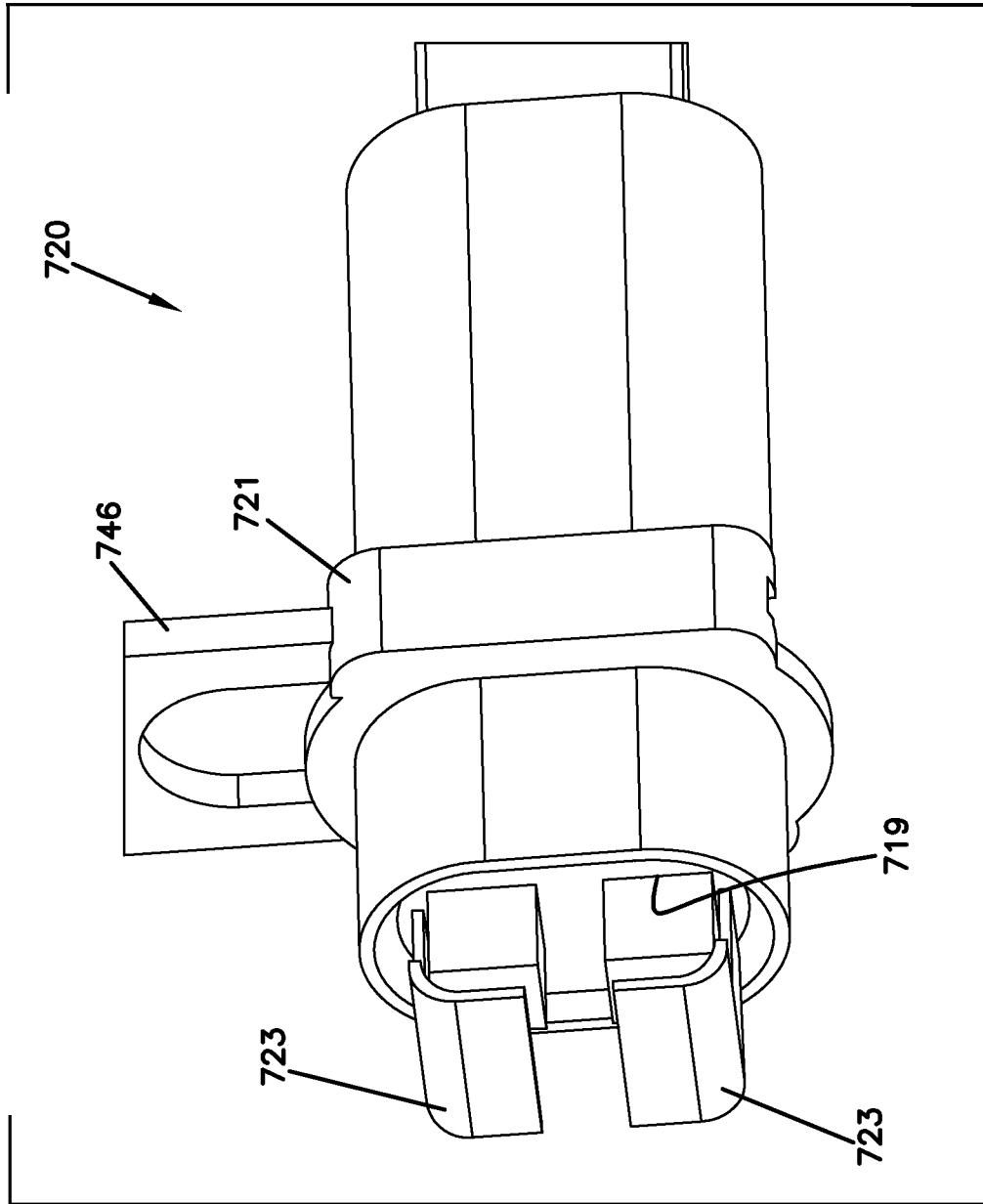
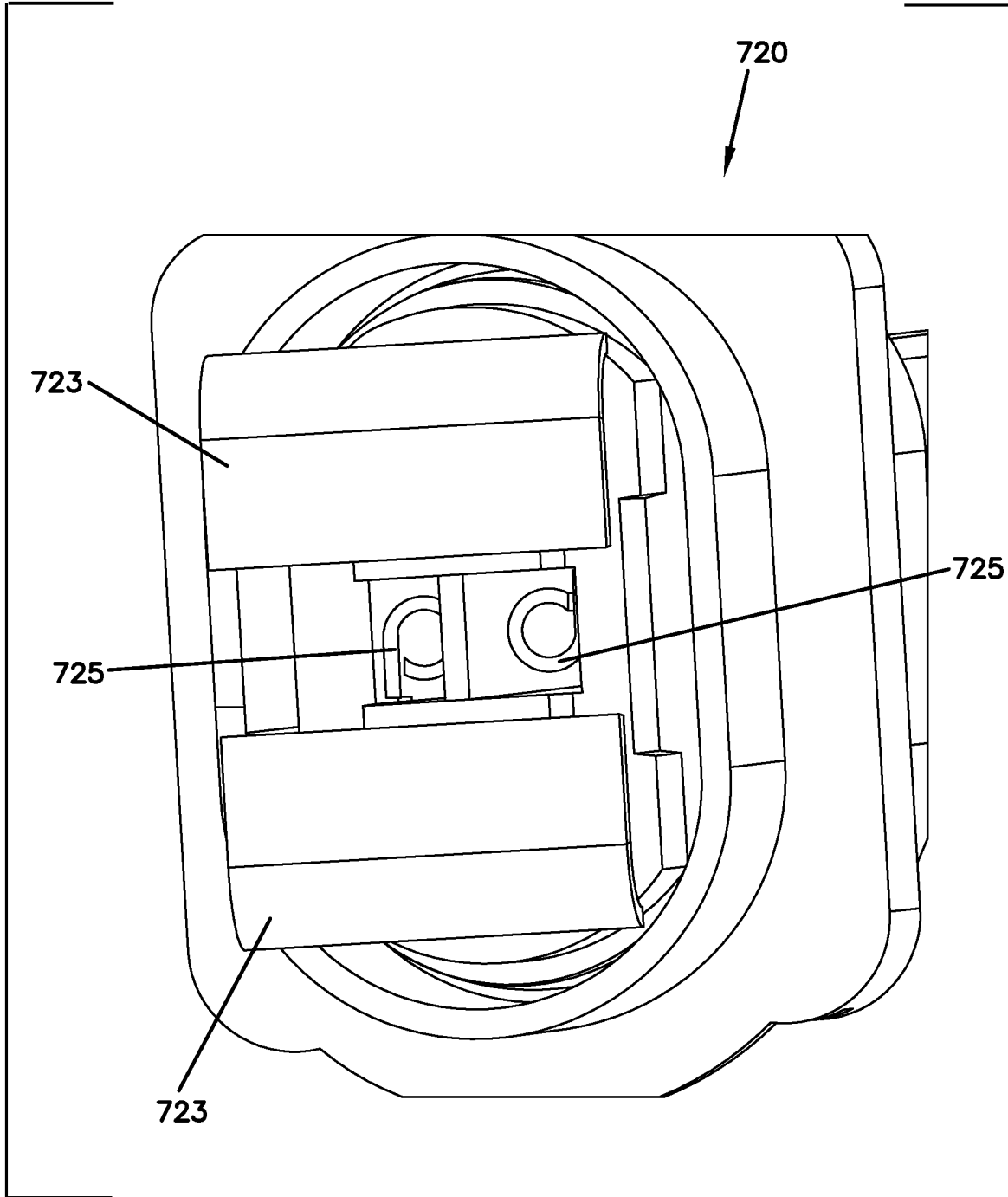

FIG. 13
Canceled

FIG. 14

Canceled



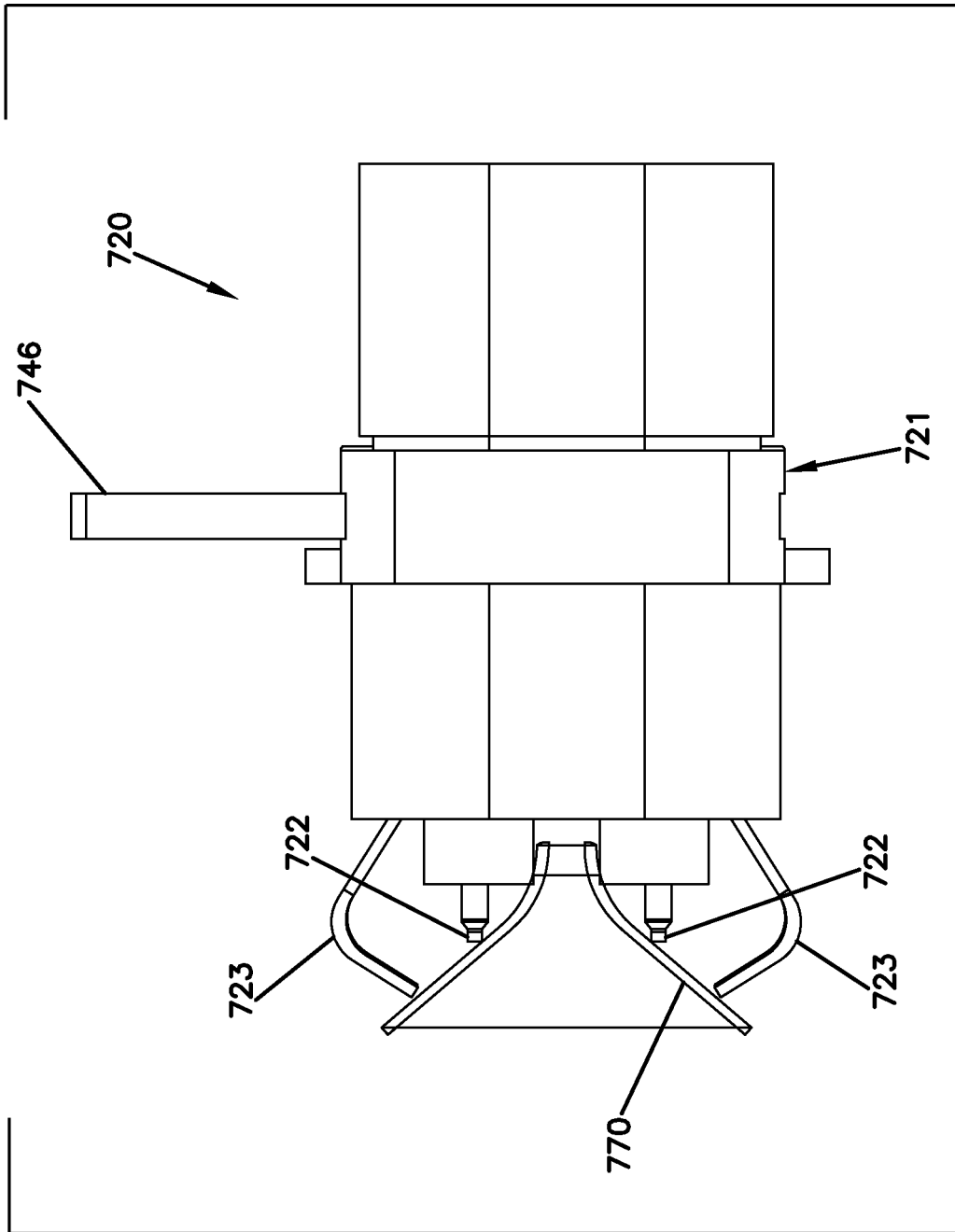

FIG. 15
Canceled

FIG. 16
Amended

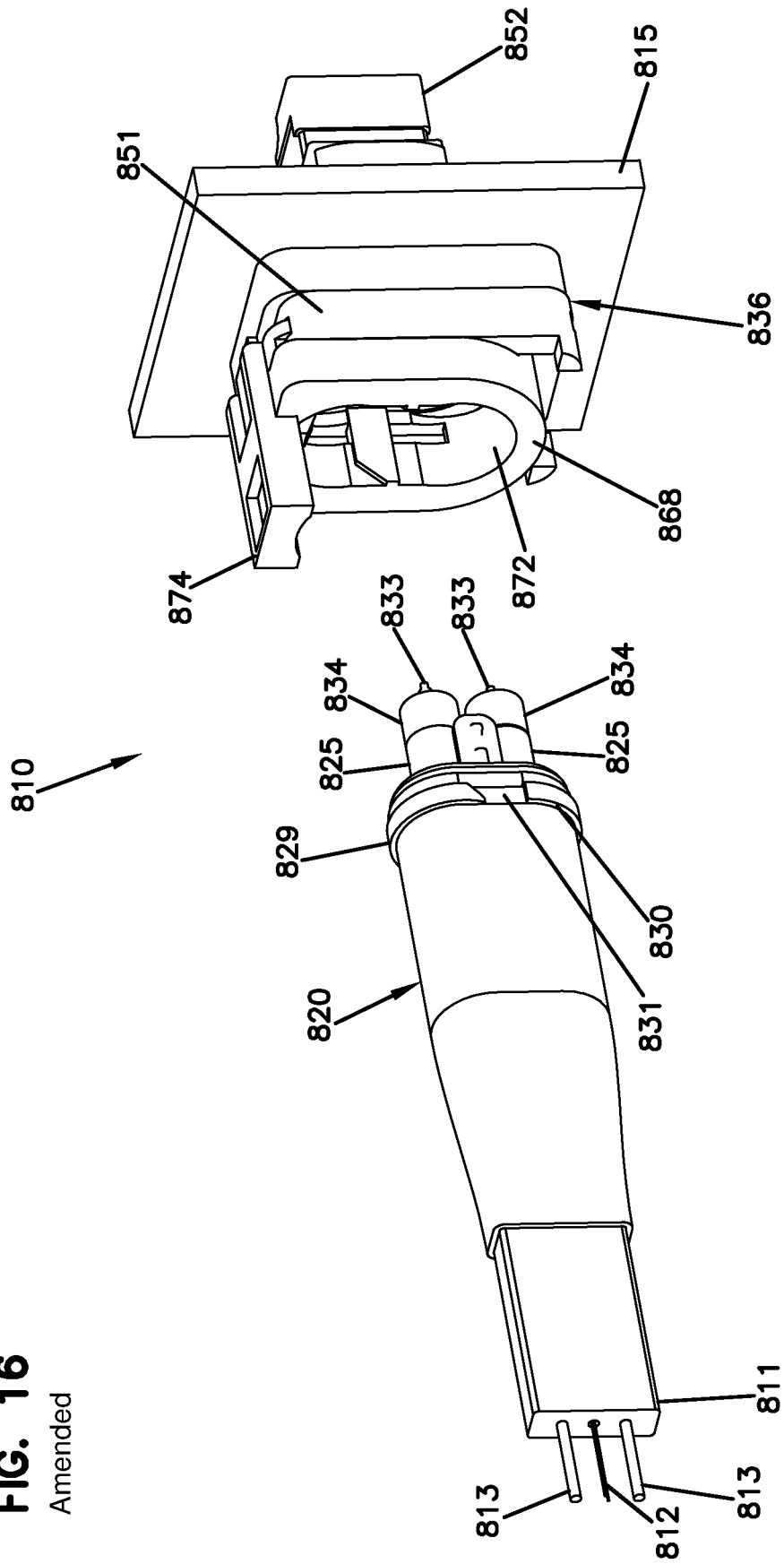

FIG. 17

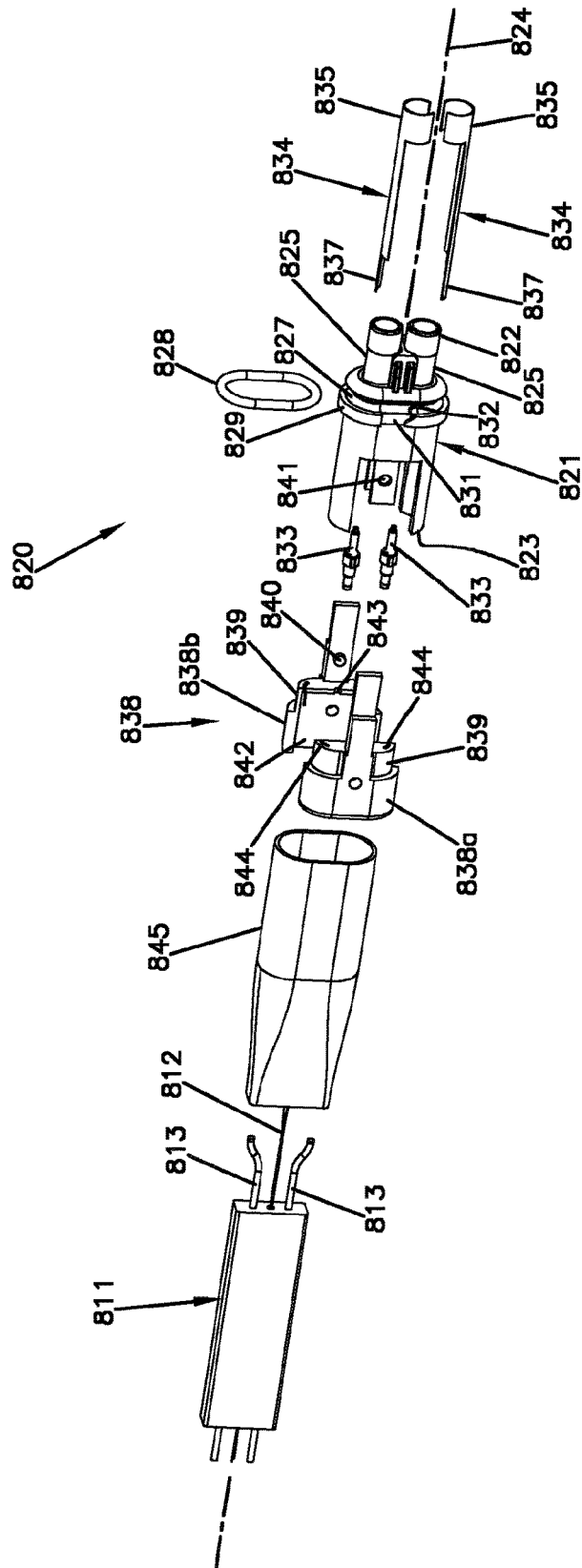
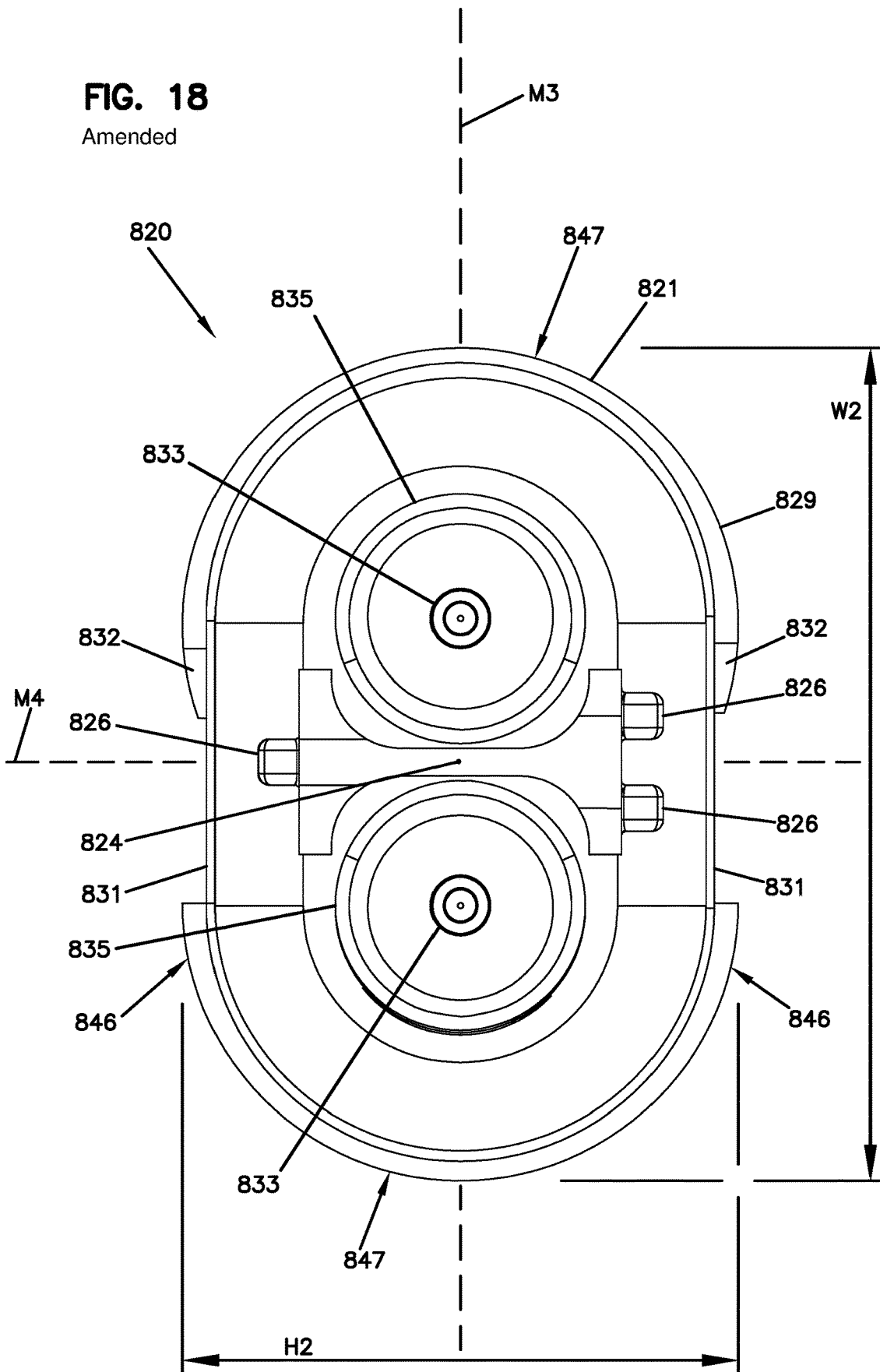

FIG. 18

Amended



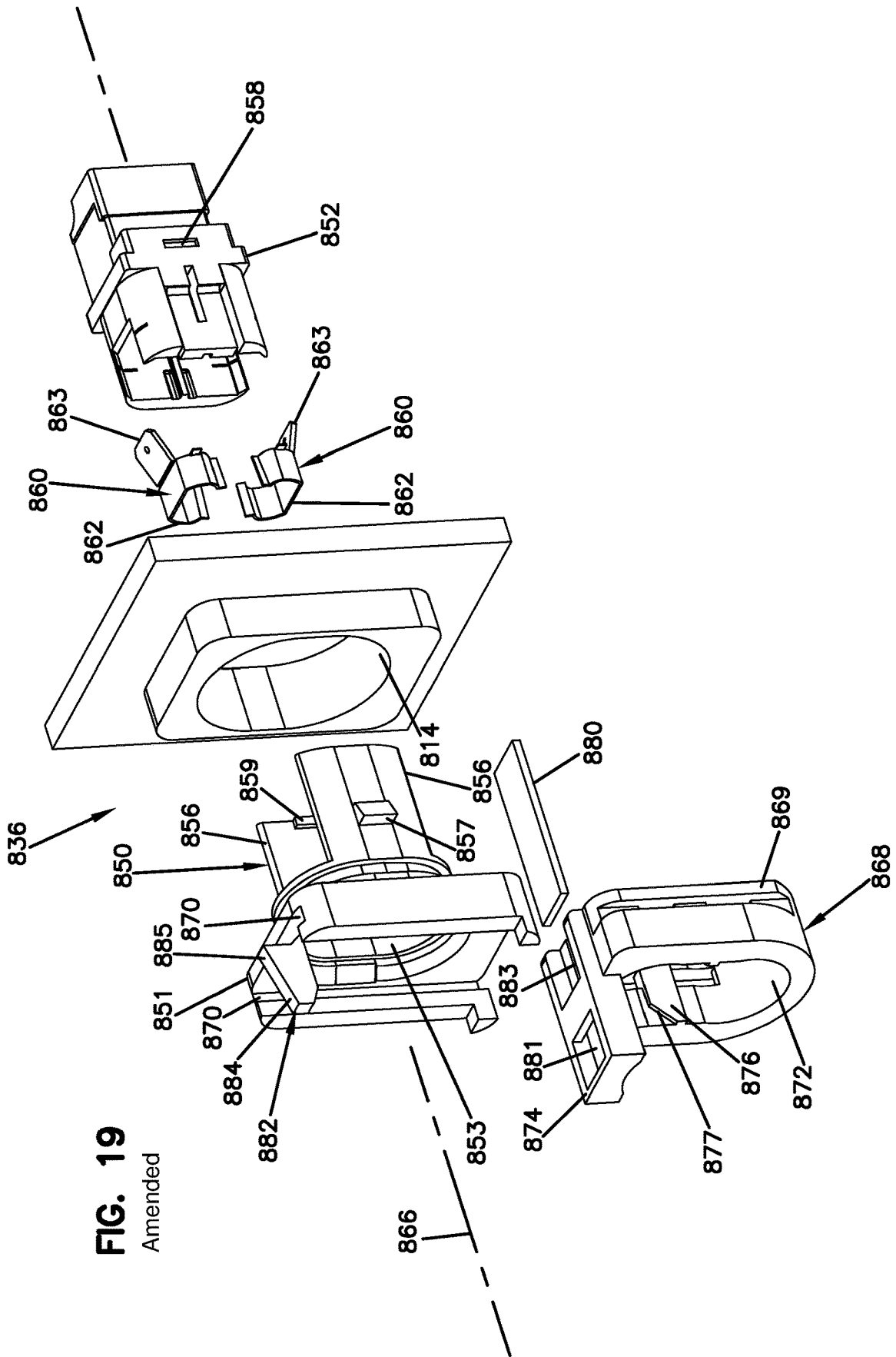
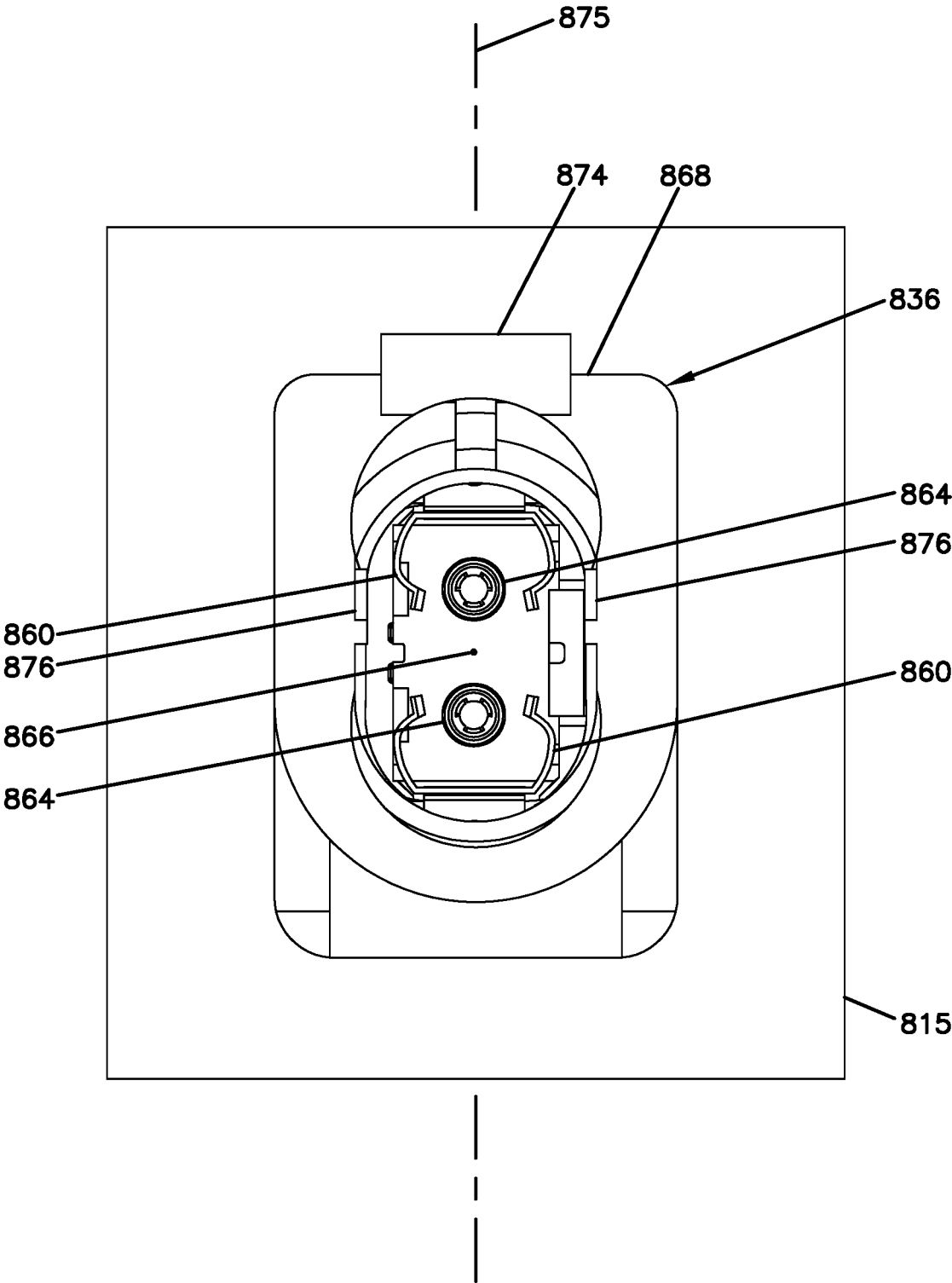

FIG. 19

Amended

FIG. 20

Amended



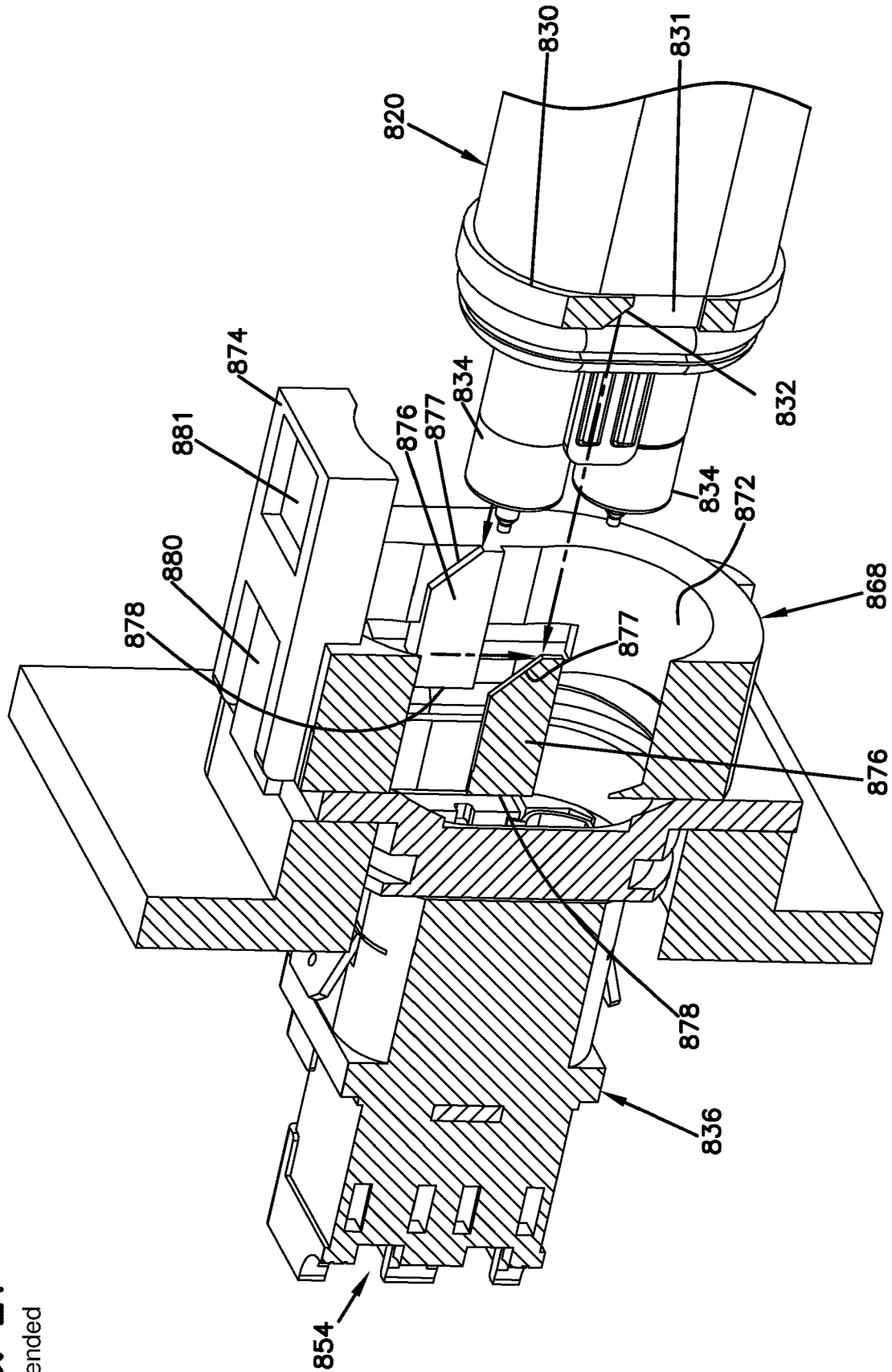

FIG. 21
Amended

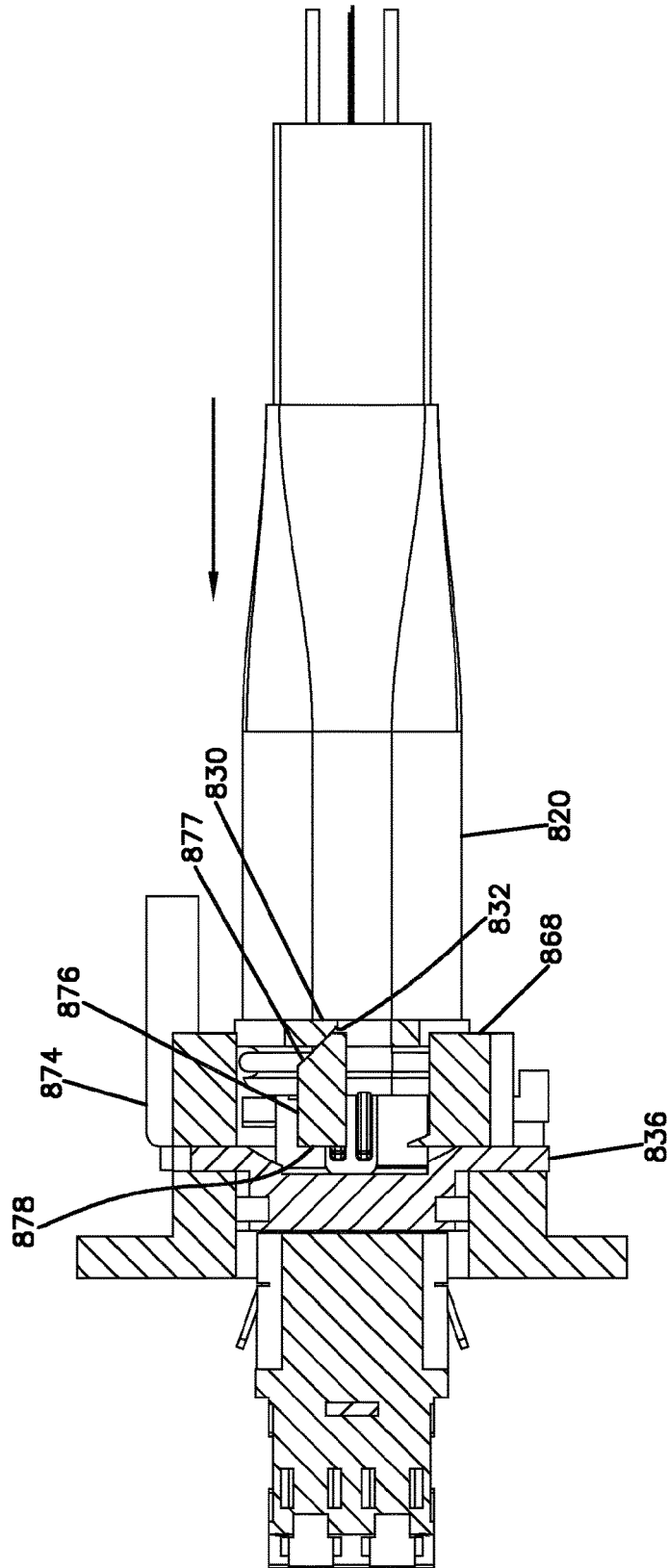

FIG. 22

FIG. 23

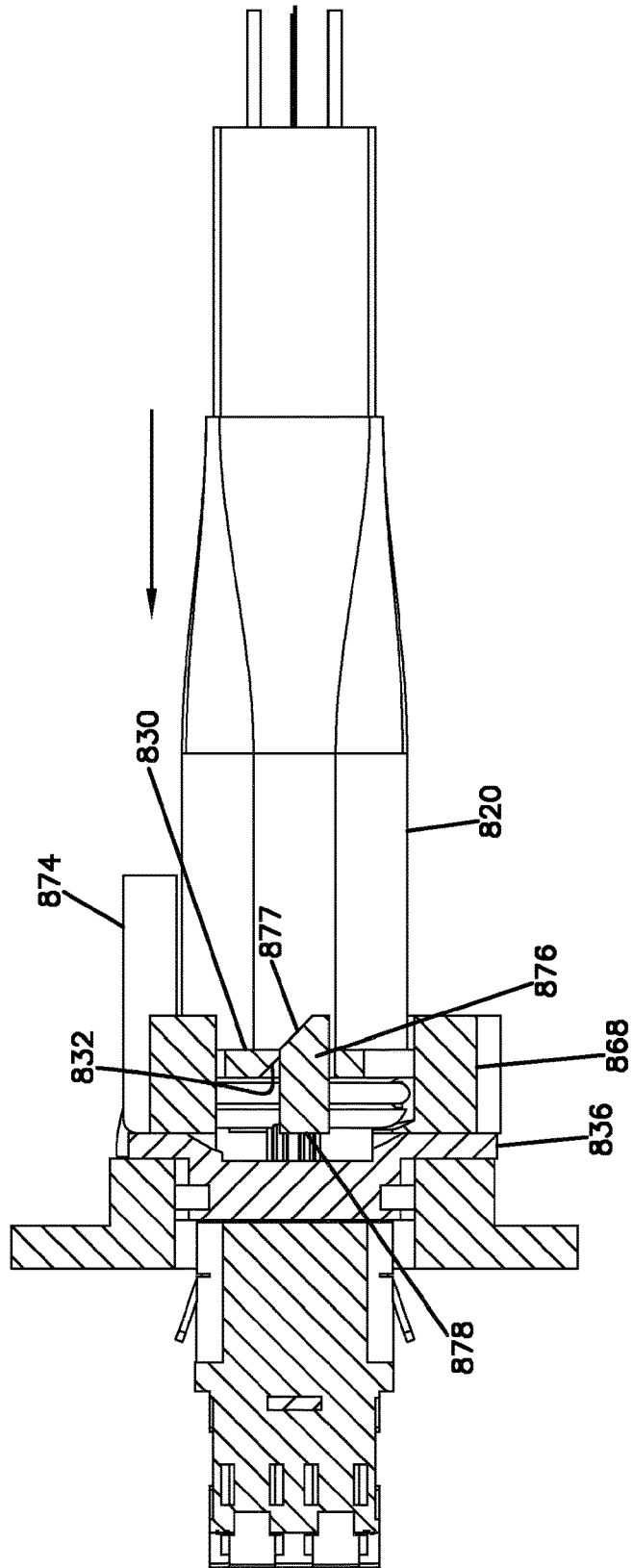
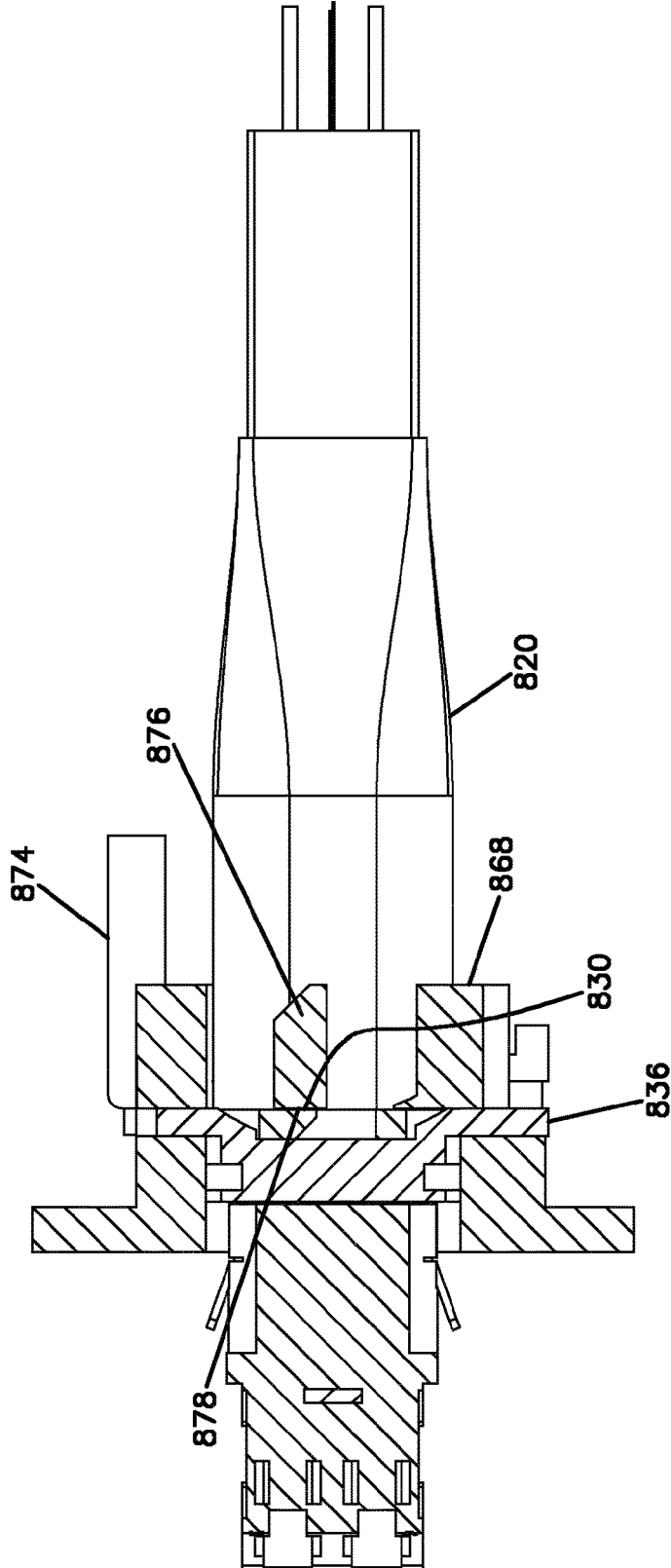

FIG. 24



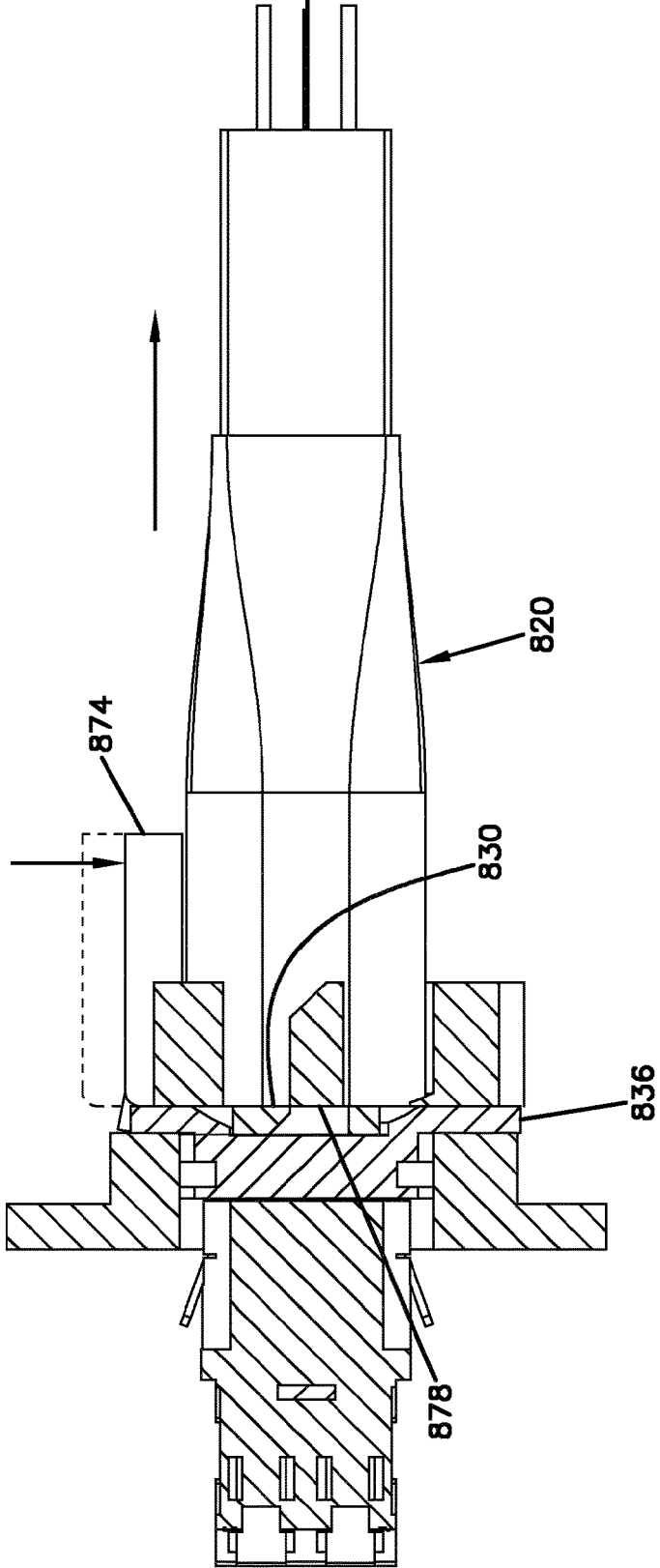

FIG. 25

FIBER OPTIC CONNECTION SYSTEM

Matter enclosed in heavy brackets [] appears in the original patent but forms no part of this reissue specification; matter printed in italics indicates the additions made by reissue; a claim printed with strikethrough indicates that the claim was canceled, disclaimed, or held invalid by a prior post-patent action or proceeding.

CROSS-REFERENCE TO RELATED APPLICATION

Notice: More than one reissue application has been filed for the reissue of U.S. Pat. No. 10,422,962 B2. The reissue applications are: U.S. application Ser. No. 17/003,664, filed Aug. 26, 2020; this U.S. application Ser. No. 17/012,859, filed Sep. 4, 2020, which is a continuation reissue of U.S. application Ser. No. 17/003,664; and U.S. application Ser. No. 17/012,884, filed Sep. 4, 2020, which is also a continuation reissue of U.S. application Ser. No. 17/003,664.

This application is a continuation reissue of U.S. application Ser. No. 17/003,664, filed on Aug. 26, 2020, which is an application for reissue of U.S. Pat. No. 10,422,962 B2, which issued from U.S. application Ser. No. 16/018,895, filed Jun. 26, 2018, which is a continuation of U.S. [patent] application Ser. No. 15/300,147, filed Sep. 28, 2016, now U.S. Pat. No. 10,061,090 B2, which is a National Stage Application of PCT/EP2015/056720, filed Mar. 27, 2015, which claims the benefit of U.S. Provisional [Patent] Application [Ser.] No. 61/971,739, filed Mar. 28, 2014, and which applications], U.S. application Ser. No. 15/300,147, International Application No. PCT/EP2015/056720, and U.S. Provisional Application No. 61/971,739 are incorporated herein by reference. To the extent appropriate, a claim of priority is made to each of the above disclosed applications.

BACKGROUND

In today's telecommunications market there is growing demand to support active devices such as fixed location transceivers for generating wireless communication coverage areas (e.g., Wi-Fi access points, macrocells, microcells, picocells, femtocells, other cell sizes, wireless hot spots, nodes, etc.), power-over-Ethernet extenders, Optical Network Terminals (ONT) that provide optical to electrical signal conversion, and IP devices (e.g., digital cameras such as security cameras, computing devices, etc.). There is also desire to support such devices with faster transmission rates, higher power and longer spans. To achieve faster transmission rates, it is desirable to support such active devices using an optical fiber network. However, traditional fiber optic networks are generally passive (e.g., passive optical local area networks (POLAN), fiber-to-the-home (FTTH), fiber-to-the-desk (FTTD), fiber-to-the-node (FTTN), fiber-to-the-curb (FTTC) and other network architectures) and therefore do not provide ready access to power. Thus, there is a need to support active devices with both electrical power and optical signals in a cost-effective manner. There is also a need to integrate hybrid connectivity (e.g., both electrical power and fiber optics) into existing fiber optic networks.

SUMMARY

Aspects of the present disclosure relate to connectors and connector systems capable of providing optical connections

and electrical power connections in a telecommunications network such as a fiber optic network. In certain examples, the connectors and connector systems can be hardened (e.g., sealed and ruggedized) for use in outdoor environmental applications. In certain examples, the connectors and connector systems can be used to provide efficient power and fiber connections in a mobile network topology. In certain examples, the connectors and connector systems can be used with cables having central sections containing optical fibers and strippable outer sections including electrical power conductors. In certain examples, the hybrid connectors can be small form-factor connectors. In certain examples, the hybrid connectors can be suitable for use in indoor passive optical local area networks or outdoor networks. In certain examples, the hybrid connectors can include robust configurations for providing retention of the connectors within mating fiber optic adapters. In certain examples, active robust coupling structure can be provided with the fiber optic adapters rather than the connectors.

Another aspect of the present disclosure relates to a hybrid fiber optic connector including a connector body having a transverse cross-sectional shape. The connector body includes two generally cylindrical sleeves at a front of the connector body. The two generally cylindrical sleeves each include a separate ferrule mounted therein. Electrical contacts mount over the two generally cylindrical sleeves so as to be carried with the connector body.

A further aspect of the present disclosure relates to a fiber optic connector including a connector body that supports first and second ferrules each supporting an optical fiber. The fiber optic connector also includes first and second shutters pivotally movable relative to the connector body between open and closed positions. The first shutter corresponds to the first ferrule and the second shutter corresponds to the second ferrule. End faces of the first and second ferrules are covered when the first and second shutters are in the closed position. The end faces of the first and second ferrules are accessible when the first and second shutters are in the open position.

Still another aspect of the present disclosure relates to a hybrid fiber optic connector including a connector body that supports first and second ferrules each supporting an optical fiber. The hybrid fiber optic connector also includes electrical contacts mounted in a region between the first and second ferrules.

A further aspect of the present disclosure relates to a fiber optic connection system including a connector body that supports at least one ferrule supporting at least one optical fiber, and a fiber optic adapter defining a port for receiving the connector body. The fiber optic connection system also includes an environmental seal for providing a seal between the connector body and the fiber optic adapter. The fiber optic connection system further includes a robust active coupler mounted to the fiber optic adapter and not carried with the connector body. The robust active coupler is movable relative to the fiber optic adapter and is configured to retain the connector body within the port. The robust active coupler is configured to retain the connector body within the port so as to withstand a pull-out force of at least 25 pounds.

Still another aspect of the present disclosure relates to a fiber optic connection system including a connector body that supports at least one ferrule supporting at least one optical fiber, and a fiber optic adapter defining a port for receiving the connector body. The system also includes a slide clip mounted to the fiber optic adapter and not carried with the connector body. The slide clip is movable relative

3

to the fiber optic adapter between a coupling position and non-coupling position. The slide clip is configured to retain the connector body within the port when in the coupling position, and is configured to allow removal of the connector body from the port when in the non-coupling position.

A further aspect of the present disclosure relates to a hardened fiber optic connection system. The system includes a fiber optic connector defining a longitudinal axis, and a fiber optic adapter defining a port for receiving the fiber optic connector. The system also includes a seal for providing environmental sealing between the fiber optic connector and the fiber optic adapter when the fiber optic connector is received within the port of the fiber optic adapter. The system further includes a retention clip mounted on the fiber optic connector or the fiber optic adapter for retaining the fiber optic connector within the port of the fiber optic adapter. The retention clip is configured to slide in a transverse orientation relative to the longitudinal axis between a coupling position and a non-coupling position. A spring is provided for biasing the retention clip towards the coupling position. The retention clip slides from the coupling position to the non-coupling position as the fiber optic connector is being axially inserted into the port of the fiber optic adapter. The spring move the retention clip from the non-coupling position back to the coupling position once the fiber optic connector has been fully axially inserted into the port of the fiber optic adapter.

BRIEF DESCRIPTION OF THE DRAWINGS

FIG. 1 is a system diagram showing an example distribution architecture including wireless coverage areas deployed using a power and optical fiber interface system;

FIG. 2 is a transverse cross-sectional view of an electrical power/optical fiber hybrid cable used in the architecture of FIG. 1 and taken along section line 2-2 shown in FIG. 1;

FIG. 3 is a perspective view of a portion of the hybrid cable of FIG. 2 with electrically conductive portions of the cable showing separated from a central optical fiber portion of the cable;

FIG. 4 is a plan view of the hybrid cable of FIGS. 2 and 3 with the electrically conductive portions of the hybrid cable trimmed relative to the central fiber optic portion of the hybrid cable;

FIG. 5 is a transverse cross-sectional view of another electrical power/optical fiber hybrid cable in accordance with principles of the present disclosure;

FIG. 6 is a perspective view of a hybrid electrical and fiber optic connector in accordance with the principles of the present disclosure;

FIG. 7 is another view of the hybrid electrical and fiber optic connector in accordance with the principles of the present disclosure;

FIG. 8 is a front end view of the hybrid electrical and fiber optic connector of FIGS. 6 and 7;

FIG. 9 shows a fiber optic adapter configured to receive the hybrid electrical and fiber optic connector of FIGS. 6-8 within an outer port of the fiber optic adapter;

FIG. 10 is another view of the fiber optic adapter of FIG. 9;

FIG. 11 is [still another] a cross-sectional view of the fiber optic adapter of FIG. 9;

FIG. 12 is an end perspective view of the adapter of FIGS. 9-11 showing an inner end defining an inner port adapted to receive LC fiber optic connectors (e.g., duplex LC connectors);

4

[FIG. 13 shows another hybrid electrical and fiber optic connector in accordance with the principles of the present disclosure with protective shutters shown in a closed position suitable for covering the ferrule ends;]

FIG. 14 is another view of the hybrid electrical and fiber optic connector of FIG. 13 with the shutters in the closed position;

FIG. 15 illustrates the hybrid electrical and fiber optic connector of FIGS. 13 and 14 with shutters shown in an open position;

FIG. 16 shows another hybrid optical and electrical connection system in accordance with the principles of the present disclosure;

FIG. 17 is an exploded view of a hybrid connector of the hybrid optical and electrical connection system of FIG. 16; FIG. 18 is a front end view of the hybrid connector of FIG. 17;

FIG. 19 is an exploded view of a hybrid adapter of the hybrid optical and electrical connection system of FIG. 16;

FIG. 20 is a partial cross-sectional view of the hybrid optical and electrical connection system of FIG. 16;

FIG. 21 is a cross-sectional view showing the hybrid connector aligned with a port of the hybrid adapter, a slide clip of the hybrid adapter is shown in a coupling position;

FIG. 22 is a cross-sectional view showing the hybrid connector inserted into the fiber optic adapter to a point where a ramp surface of the hybrid connector engaging a ramp surface of the slide clip, the slide clip is still in the coupling position;

FIG. 23 is a cross-sectional view showing the hybrid connector inserted into the fiber optic adapter to a point where engagement of the ramp surfaces has caused the slide clip to move to a non-coupling position adapted for allowing the hybrid connector to pass through the slide clip;

FIG. 24 is a cross-sectional view showing the hybrid connector fully inserted into the fiber optic adapter and the slide clip moved to a coupling position where the slide clip retains the hybrid connector within the hybrid adapter; and

FIG. 25 is a cross-sectional view showing the hybrid connector fully inserted into the fiber optic adapter and the slide clip being manually depressed to the non-coupling position so as to allow the hybrid connector to be removed from the hybrid adapter.

DETAILED DESCRIPTION

In the following Detailed Description, reference is made to the accompanying drawings, which form a part hereof, and in which is shown by way of illustration specific embodiments in which the invention may be practiced. In this regard, directional terminology, such as top, bottom, front, back, etc., is used with reference to the orientation of the Figure(s) being described. Because components of embodiments can be positioned in a number of different orientations, the directional terminology is used for purposes of illustration and is in no way limiting. It is to be understood that other embodiments may be utilized and structural or logical changes may be made without departing from the scope of the present invention. The following detailed description, therefore, is not to be taken in a limiting sense.

FIG. 1 shows a system 10 in accordance with the principles of the present disclosure for enhancing the coverage areas provided by cellular technologies (e.g., GSM, CDMA, UMTS, LTE, WiMax, WiFi, etc.). The system 10 includes a base location 11 (i.e., a hub) and a plurality of wireless coverage area defining equipment 12a, 12b, 12c, 12d, 12e and 12f (sometimes collectively referred to as equipment 12

herein) distributed about the base location **11**. In certain examples, the base location **11** can include a structure **14** (e.g., a closet, hut, building, housing, enclosure, cabinet, etc.) protecting telecommunications equipment such as racks, fiber optic adapter panels, passive optical splitters, wavelength division multiplexers, fiber splice locations, optical fiber patching and/or fiber interconnect structures and other active and/or passive equipment. In the depicted example, the base location **11** is connected to a central office **16** or other remote location by a fiber optic cable such as a multi-fiber optical trunk cable **18** that provides high bandwidth two-way optical communication between the base location **11** and the central office **16** or other remote location. In the depicted example, the base location **11** is connected to the wireless coverage area defining equipment **12a**, **12b**, **12c**, **12d**, **12e** and **12f** by hybrid cables **20**. The hybrid cables **20** are each capable of transmitting both power and communications between the base location **11** and the wireless coverage area defining equipment **12a**, **12b**, **12c**, **12d**, **12e** and **12f**.

The wireless coverage area defining equipment **12a**, **12b**, **12c**, **12d**, **12e** and **12f** can each include one or more wireless transceivers **22**. The transceivers **22** can include single transceivers **22** or distributed arrays of transceivers **22**. As used herein, a "wireless transceiver" is a device or arrangement of devices capable of transmitting and receiving wireless signals. A wireless transceiver typically includes an antenna [for enhancing] that enhances receiving and transmitting [the] wireless signals. Wireless coverage areas are defined around each of the wireless coverage area defining equipment **12a**, **12b**, **12c**, **12d**, **12e** and **12f**. Wireless coverage areas can also be referred to as cells, cellular coverage areas, wireless coverage zones, or like terms. Examples of and/or alternative terms for wireless transceivers include radio-heads, wireless routers, cell sites, wireless nodes, etc.

In the depicted example of FIG. 1, the base location **11** is shown as a base transceiver station (BTS) located adjacent to a radio tower **24** supporting and elevating a plurality of the wireless coverage area defining equipment **12a**. In one example, the equipment **12a** can define wireless coverage areas such as [a] macrocells or microcells (i.e., cells each having a coverage area less than or equal to about 2 kilometers wide). The wireless coverage area defining equipment **12b** is shown deployed at a suburban environment (e.g., on a light pole in a residential neighborhood) and the equipment **12c** is shown deployed at a roadside area (e.g., on a roadside power pole). The equipment **12c** could also be installed at other locations such as tunnels, canyons, coastal areas, etc. In one example, the equipment **12b**, **12c** can define wireless coverage areas such as microcells or picocells (i.e., cells each having a coverage area equal to or less than about 200 meters wide). The equipment **12d** is shown deployed at a campus location (e.g., a university or corporate campus), the equipment **12e** is shown deployed at a large public venue location (e.g., a stadium), and the equipment **12f** is shown installed at an in-building or near-building environment (e.g., multi-dwelling unit, high rise, school, etc.). In one example, the equipment **12d**, **12e**, and **12f** can define wireless coverage areas such as microcells, picocells, or femtocells (i.e., cells each having a coverage area equal to or less than about 10 meters wide).

The wireless coverage area defining equipment **12** are often located in areas without power outlets conveniently located. As noted above, the hybrid cable **20** provides both power and data to the equipment **12**. FIG. 2 is a transverse cross-sectional view taken through an example of one of the hybrid cables **20** of FIG. 1. Hybrid cable **20** includes an

outer jacket **100** having a transverse cross-sectional profile that defines a major axis **102** and a minor axis **104**. The outer jacket has a height **H** measured along the minor axis **104** and a width **W** measured along the major axis **102**. The width **W** is greater than the height **H** such that the transverse cross-sectional profile of the outer jacket **100** is elongated along the major axis **102**.

The outer jacket **100** can include a left portion **106**, a right portion **108** and a central portion **110**. The left portion **106**, the right portion **108** and the central portion **110** can be positioned along the major axis **102** with the central portion **110** being disposed between the left portion **106** and the right portion **108**. The left portion **106** can define a left passage **112**, the right portion **108** can define a right passage **114** and the central portion **110** can define a central passage **116**. The passages **112**, **114** and **116** can have lengths that extend along a central longitudinal axis **118** of the cable **20** for the length of the cable. A left electrical conductor **120** is shown positioned within the left passage **112**, a right electrical conductor **122** is shown positioned within the right passage **114** and at least one optical fiber **124** is shown positioned within the central passage **116**. Certain embodiments include from 1 to 12 fibers **124**, for example. The left electrical conductor **120**, the right electrical conductor **122** and the optical fiber **124** have lengths that extend along the central longitudinal axis **118** of the cable **20**.

Still referring to FIG. 2, the hybrid cable **20** includes a left pre-defined tear location **126** positioned between the central portion **110** and the left portion **106** of the outer jacket **100**, and a right pre-defined tear location **128** positioned between the central portion **110** and the right portion **108** of the outer jacket **100**. The left pre-defined tear location **126** is weakened such that the left portion **106** of the outer jacket **100** can be manually torn from the central portion **110** of the outer jacket **100**. Similarly, the right pre-defined tear location **128** is weakened such that the right portion **108** of the outer jacket **100** can be manually torn from the central portion **110** of the outer jacket **100**. The left pre-defined tear location **126** is configured such that the left portion **106** of the outer jacket **100** fully surrounds the left passage **112** and the central portion **110** of the outer jacket **100** fully surrounds the central passage **116** after the left portion **106** of the outer jacket **100** has been torn from the central portion **110** of the outer jacket **100**. In this way, the left electrical conductor **120** remains fully insulated and the optical fiber **124** remains fully protected after the left portion **106** has been torn from the central portion **110**. The right pre-defined tear location **128** is configured such that the right portion **108** of the outer jacket **100** fully surrounds the right passage **114** and the central portion **110** of the outer jacket **100** fully surrounds the central passage **116** after the right portion **108** of the outer jacket **100** has been torn from the central portion **110** of the outer jacket **100**. In this way, the right electrical conductor **122** remains fully insulated and the optical fiber **124** remains fully protected after the right portion **108** has been torn from the central portion **110**.

FIG. 3 shows the hybrid cable **20** with both the left portion **106** and the right portion **108** torn away from the central portion **110**. In this configuration, both the left electrical conductor **120** and the right electrical conductor **122** are fully insulated by their corresponding left and right portions **106**, **108**. Additionally, the central portion **110** has a rectangular transverse cross-sectional shape that fully surrounds the central passage **116** so as to protect the optical fiber or fibers **124**.

It will be appreciated that the left and right electrical conductors **120**, **122** have a construction suitable for carry-

ing electricity. It will be appreciated that the electrical conductors can have a solid or stranded construction. Example sizes of the electrical conductors include 12 gauge, 16 gauge, or other sizes.

The outer jacket **100** is preferably constructed of a polymeric material. In one example, the hybrid cable **20** and the outer jacket **100** are plenum rated. In certain examples, the outer jacket **100** can be manufactured of a fire-retardant plastic material. In certain examples, the outer jacket **100** can be manufactured of a low smoke zero halogen material. Example materials for the outer jacket include polyvinyl chloride (PVC), fluorinated ethylene polymer (FEP), polyolefin formulations including, for example, polyethylene, and other materials.

The central passage **116** can contain one or more optical fibers **124**. In certain examples, the optical fibers **124** can be coated optical fibers having cores less than 12 microns in diameter, cladding layers less than 240 microns in diameter, and coating layers less than 300 microns in diameter. It will be appreciated that the core and cladding layers typically include a silica based material. In certain examples, the cladding layer can have an index of a refraction that is less than the index of refraction of the core to allow optical signals that are transmitted through the optical fibers to be confined generally to the core. It will be appreciated that in certain examples, multiple cladding layers can be provided. In certain examples, optical fibers can include bend insensitive optical fibers having multiple cladding layers separated by trench layers. In certain examples, protective coatings (e.g., a polymeric material such as acelate) can form coating layers around the cladding layers. In certain examples, the coating layers can have diameters less than 300 microns, or less than 260 microns, or in the range of 240 to 260 microns. In certain examples, the optical fibers **124** can be unbuffered. In other examples, the optical fibers can include a tight buffer layer, a loose buffer layer, or a semi-tight buffer layer. In certain examples, the buffer layers can have an outer diameter of about 800 to 1,000 microns. The optical fibers can include single mode optical fibers, multi-mode optical fibers, bend insensitive fibers or other fibers. In still other embodiments, the optical fibers **124** can be ribbonized.

As shown at FIG. 4, the left and right portions **106**, **108** can be trimmed relative to the central portion **110** after the left and right portions **106**, **108** have been torn away from the central portion **110**. In this configuration, the central portion **110** extends distally beyond the ends of the left and right portions **106**, **108**. In certain examples, insulation displacement connectors can be used to pierce through the jacket materials of the left and right portions **106**, **108** to electrically connect the left and right electrical connectors **120**, **122** to an electrical power source, ground, active components or other structures. It will be appreciated that the optical fibers **124** can be connected to other fibers with mechanical or fusion splices, or directly terminated with optical connectors. In other examples, connectorized pigtailed can be spliced to the ends of the optical fibers **124**.

Referring back to FIG. 2, the outer jacket **100** includes a top side **130** and a bottom side **132** separated by the height H. As depicted, the top and bottom sides **130**, **132** are generally parallel to one another. Each of the left and right pre-defined tear locations **126**, **128** includes an upper slit **134** that extends downwardly from the top side **130**, a lower slit **136** that extends upwardly from the bottom side **132** and a non-slitted portion **138** positioned between the upper and lower slits **134**, **136**. In one example embodiment, the upper and lower slits **134**, **136** are partially re-closed slits. In the

depicted embodiment, the left and right pre-defined tear locations **126**, **128** also include jacket weakening members **140** that are imbedded in the non-slitted portions **138**. By way of example, the jacket weakening members **140** can include strands, monofilaments, threads, filaments or other members. In certain examples, the jacket weakening members **140** extend along the central longitudinal axis **118** of the cable **20** for the length of the cable **20**. In certain examples, the jacket weakening members **140** are aligned along the major axis **102**. In certain examples, the upper and lower slits **134**, **136** as well as the jacket weakening member **140** of the left pre-defined tear location **126** are aligned along a left tearing plane PL that is oriented generally perpendicular relative to the major axis **102**. Similarly, the upper and lower slits **134**, **136** as well as the jacket weakening member **140** of the right pre-defined tear location **128** are aligned along a right tearing plane PR that is oriented generally perpendicular with respect to the major axis **102**.

Referring again to FIG. 2, the hybrid cable **20** can include a tensile strength structure **142** that provides tensile enforcement to the hybrid cable **20** so as to prevent tensile loads from being applied to the optical fibers **124**. In certain embodiments, the tensile strength structure **142** can include reinforcing structures such as Aramid yarns or other reinforcing fibers. In still other embodiments, the tensile strength structure **142** can have an oriented polymeric construction. In still other examples, a tensile strength structure **142** can include a reinforcing tape. In certain examples, the reinforcing tape can be bonded to the outer jacket **100** so as to line the central passage **116**. In certain examples, no central buffer tube is provided between the optical fibers **124** and the tensile reinforcing structure **142**. In certain examples, the tensile strength structure **142** can include a reinforcing tape that extends along the length of the hybrid cable **20** and has longitudinal edges/ends **[144]** that are separated so as to define a gap **144** therein between. In use, the tensile strength member **142** can be anchored to a structure such as a fiber optic connector, housing or other structure so as to limit the transfer of tensile load to the optical fibers **124**. It will be appreciated that the tensile strength structure **142** can be anchored by techniques such as crimping, adhesives, fasteners, bands or other structures.

FIG. 5 shows an alternative hybrid cable **20'** having the same construction as the hybrid cable **20** except two tensile strength structures **142a**, **142b** have been provided within the central passage **116**. Tensile strength members **142a**, **142b** each include a tensile reinforcing tape that is bonded to the central portion **110** of the outer jacket **100**. The tensile strength members **142a**, **142b** can include portions that circumferentially overlap one another within the central passage **116**. In certain examples, by stripping away an end portion of the central portion **110**, the tensile strength structures **142a**, **142b** can be exposed and readily secured to a structure such as a fiber optic connector, a panel, a housing or other structure.

As noted above, the electrical conductors **120**, **122** could be 12 gauge (AWG) or 16 gauge, for example. In certain examples, a 12 gauge conductor **120**, **[120]** **122** provides up to 1175 meter reach at 15 W, and a 750 meter reach for 25 W devices. The 16 gauge implementations can provide reduced cost for shorter reach applications or lower power devices, for example.

Providing power to remote active devices such as the wireless coverage area defining equipment **12** is often difficult and expensive. Providing required power protection and backup power further complicates powering such remote devices. Optical Network Terminals (ONT's) and

Small Cell devices (such as picocells and metrocells) have “similar” power requirements. For example, 25 W, 12 VDC or 48 VDC devices are common, although variations occur.

FIG. 6 illustrates a hybrid electrical and fiber optic connector 620 in accordance with the principles of the present disclosure. In one example, the connector 620 is adapted to be used in combination with the hybrid cable 20 and includes ferrules 622 that receive optical fibers of the hybrid cable 20 and also includes electrical contacts 624 that are adapted to be electrically connected to the electrical conductors 120, 122 of the hybrid cable 20. The connector 620 includes a connector body 626 having a transverse cross-sectional shape that complements or matches the transverse cross-sectional shape of the hybrid cable 20. For example, the transverse cross-sectional shape of the connector body 626 can be elongate and generally oval shaped. In one example, the transverse cross-sectional shape of the connector body 626 can include a major axis M1 and a minor axis M2 (see FIG. 8), with a height H1 measured along the minor axis M2 and a width W1 measured along the major axis M1. Preferably, the width W1 is greater than the height H1 such that the transverse cross-sectional profile of the connector body 626 is elongated along the major axis M1. In certain examples, opposite ends of the connector body 626 are rounded. In certain examples, the transverse cross-sectional profile of the connector body 626 has major sides 627 that are positioned on opposite sides of the major axis M1 and that extend along the width W1. The transverse cross-sectional profile of the connector body 626 also includes minor sides 629 that positioned on opposite sides of the minor axis M2 that extend along the height H1 between the major sides 627. The major sides 627 are parallel and extend between the minor sides 629. The minor sides 629 form opposite rounded ends of the transverse cross-sectional profile.

Referring to FIGS. 6 and 7, the connector body 626 includes two forwardly positioned, cylindrical sleeves 628. The ferrules 622 are mounted within the [sleeve] sleeves 628. An intermediate structure 630 can be positioned generally between the [sleeve] sleeves 628. Intermediate [structures] structure 630 can include a key feature 632 that ensures the connector 620 is inserted into an adapter at a suitable rotational orientation. The intermediate structure 630 can also include catches or latch features adapted to engage a latch of an adapter for receiving the connector 620. The connector body 626 defines a first peripheral groove 634 for receiving a sealing member or element such as an O-ring. The connector body 626 also includes another peripheral groove 636 (e.g., second peripheral groove) spaced from the peripheral groove 634. The second peripheral groove 636 can be adapted for receiving a retention member of an adapter configured for receiving the connector 620. For example, when the connector 620 is inserted within the adapter, the retention member can be slid or otherwise moved into the second peripheral groove 636 so as to lock the connector 620 within the adapter.

Referring still to FIGS. 6 and 7, the electrical contacts 624 are depicted as electrically conductive bands or sleeves that mount over the [sleeve] sleeves 628. In certain examples, the bands or sleeves can include an electrically conductive material such as metal.

FIGS. 9-12 illustrate an adapter 638 configured for receiving the connector 620. In certain examples, adapter 638 is configured for optically coupling the optical fibers supported by the connector 620 to [responding] corresponding optical fibers of other optical connectors. Additionally, the adapter 638 is configured for electrically connecting the electrical

[contact] contacts 624 to electrical contacts of the adapter. Electrical contacts of the adapter allow power to be routed from the connector 620 to one or more active components in need of power. Thus, optical signals can be configured to pass through the adapter 638 from the connector 620 to one or more other fiber optic connectors, while electrical power from the connector 620 is routed laterally out from the connector 620 and is not directed to the corresponding fiber optic connectors.

As depicted at FIGS. 9-11, adapter 638 includes opposite receptacles 640, 642. The receptacle 640 is adapted for receiving the connector 620, and the receptacle 642 is adapted for receiving standard fiber optic connectors (e.g., LC connectors or other types of fiber optic connectors). The adapter 638 includes internal alignment sleeves 644 for coaxially aligning the ferrules 622 of the connector 620 with corresponding ferrules of the connectors inserted within the receptacle 642. The adapter 638 can include an internal flexible latch adapted for engaging the latch feature on the connector 620. The adapter 638 also includes a locking element 646 (e.g., a clip or wedge) that is slid into the peripheral groove 636 when the connector 620 is inserted within the receptacle 640 so as to lock the connector 620 within the receptacle 640. It will be appreciated that the locking element 646 can be slid relative to the main body of the adapter 638 between a locking position and a non-locking position. When the connector 620 is inserted within the receptacle 640, the seal within the first peripheral groove 634 can provide a peripheral seal between the exterior of the connector body 626 and a corresponding sealing surface provided within the receptacle 640 of the adapter 638. It will be appreciated that the seal may be optional for certain applications such as indoor applications.

In certain examples, the locking element 646 can slide along the major axis M1 of the connector 620 when moving between the locking and unlocking positions. When in the locking position, the locking element 646 can engage the connector 620 on opposite sides of the connector body [628] 626. For example, the locking element 646 can engage both of the major sides 627 of the transverse cross-sectional profile of the connector body [628] 626 so that retaining engagement is provided on opposite sides of the major axis M1. In other examples, an alternate locking element may slide along the minor axis M2 and provide retaining engagement on opposite sides of the minor axis M2 (e.g., the locking element may engage both of the minor sides of the transverse cross-sectional profile of the connector).

In certain examples, the locking element 646 provides robust retention of the connector body [628] 626 within the fiber optic adapter 638. In certain examples, the locking element 646 engages the connector body [628] 626 such that the connection can resist a pull-out force of at least 25 pounds or at least 50 pounds. In certain examples, the locking element 646 can be mounted with the fiber optic adapter 638 and not carried with the connector body [628] 626. Thus, the active portion (i.e., the movable portion) of the robust retention system can be provided with the fiber optic adapter and not the connector. This allows the fiber optic connector to have a transverse cross-sectional shape with a relatively small form factor. A connector with a small cross-sectional form factor can assist in routing connectorized cables along various pathways having relatively small clearances. In one example, the maximum width W1 of the transverse cross-sectional shape of the connector 620 is less than 2 centimeters and the maximum height H1 of the transverse cross-sectional shape of the connector 620 is less than 1.5 centimeters. In one example, the maximum width

W1 is about 1.8 centimeters and the maximum height H1 is about 1.2 centimeters. In certain examples, the active portion of the retention system that is integrated within the adapter can include a slide clip. In other examples, the active portion of the retention system that is integrated or otherwise included with the adapter includes other structures such as rotating sleeves, collars, nuts or other fastening elements that may include fastening parts such as threads, bayonet structures or other structures.

The adapter 638 can include an adapter flange 648 and an external latch 650. The flange 648 and the latch 650 can be configured to secure the adapter 638 within an opening such as an opening in a panel or in an enclosure. In certain examples, a seal can be provided adjacent the flange for providing a seal between the adapter 638 and the structure to which the adapter is mounted.

Referring to FIGS. 9 and 10, electrical contacts 652 are mounted on opposite sides of the main body of the adapter 638. The electrical contacts include internal portions 654 that are positioned within the receptacle 640 and that are adapted to engage the electrical contacts 624 of the connectors 620 when the connector 620 is secured within the receptacle 640. The electrical contacts 652 also include external portions 656 that project outwardly from the main body of the adapter 638 so as to be accessible from the exterior of the adapter 638. The external portions 656 can be electrically connected (e.g., wired or otherwise electrically connected) to active devices in need of electrical power from the hybrid cable 20.

Referring to FIG. 11, the main body of the adapter 638 can have a two-piece construction including a first piece 658 defining the receptacle 640 and a second piece 660 defining one or more ports corresponding to the receptacle 642. In certain examples, first and second parts can be interconnected by a snap-fit connection. As shown at FIGS. 11 and 12, the second piece of the adapter 638 defines the receptacle 642 and the receptacle 642 has a duplex configuration configured for receiving two LC-style fiber optic connectors.

[FIGS. 13-15 illustrate an alternative hybrid electrical and fiber optic connector 720 in accordance with the principles of the present disclosure. The connector 720 includes two separate ferrules 722 mounted in corresponding sleeves of a connector body 719. When the connector 720 is not fully inserted within an adapter 721, shutters 723 protect end faces of the ferrules 722. As shown at FIG. 14, electrical contacts 725 can be provided at a center position between the two ferrules 722. Electrical contacts 725 are adapted to be connected to the electrical conductors of the hybrid cable 20 when the connector 720 is mounted to the end of the hybrid cable 20. Similarly, the separate ferrules 722 are adapted to receive optical fibers of the hybrid cable 20 when the connector 720 is mounted at the end of the cable 20. Similar to the previously described embodiment, the connector 720 can be secured within a corresponding adapter such as the adapter 721. The adapter 721 can include a connector retention feature such as a slide clip 746 of the type previously described. In certain examples, the adapter can include ramp structures 770 for automatically moving the shutters 723 from a closed position to an open position as the connector 720 is fully inserted within the adapter 721 (see FIG. 15). It will be appreciated that the connector body 719 of the connector 720 can have an elongate transverse cross-sectional shape and size comparable to the connector 620.]

In certain alternative examples, a sliding retention element or component (e.g., a slide clip) can be carried with the connector. When the connector is inserted within its corre-

sponding adapter, the sliding retention element can be moved from a non-retaining position to a retaining position. With the clip in the retaining position, the connector is effectively locked within the adapter.

FIG. 16 illustrates a hybrid electrical and fiber optic connection system 810 in accordance with the principles of the present disclosure. The connection system 810 is adapted to provide both optical (e.g., for fiber optic communications) and electrical (e.g., for electrical power) connectivity. The connection system 810 includes a hybrid connector 820 configured to mate with a corresponding hybrid adapter 836. The hybrid connector 820 is shown mounted at the end of a hybrid cable 811. The hybrid cable 811 is shown having an outer jacket with an elongate cross-sectional shape (i.e., flat cable). A plurality of optical fibers 812 extend through a central passage defined by the jacket. In one example, two optical fibers 812 are provided within the jacket of the hybrid cable 811. Electrical conductors 813 also extend through the jacket of the hybrid cable 811. The electrical conductors 813 are positioned on opposite sides of the central passage containing the optical fibers 812. The hybrid adapter 836 is shown mounted within a port 814 (see FIG. 19) of a structure 815 (e.g., a panel, a wall, a wall of a housing, etc.). In certain examples, the structure 815 can include an enclosure such as an optical network terminal, a camera housing, an enclosure housing wireless connectivity equipment such as small cell devices, or other types of enclosures.

Referring to FIG. 17, the hybrid connector 820 includes a connector body 821 having a front end 822 and a rear end 823. A longitudinal axis 824 of the connector extends through the hybrid connector 820 in front-to-rear direction. Two front sleeves 825 are provided at the front end 822 of the connector body 821. Keying structures 826 (see FIG. 18) are provided in a region generally between the front sleeves 825. The keying structures 826 can mate with corresponding keying structures provided in the hybrid adapter [830] 836 to ensure that the hybrid connector is oriented in the proper rotational orientation when inserted into the hybrid adapter 836.

Referring still to FIG. 17, the connector body 821 defines a peripheral groove 827 that extends around the longitudinal axis 824 and about a circumference of the connector body 821. The peripheral groove 827 is adapted for receiving a seal 828 that provides an environmental seal between the connector body 821 and the hybrid adapter 836 when the hybrid connector 820 is mated with the hybrid adapter 836. The connector body 821 also includes a peripheral retention flange 829 that extends around the longitudinal axis 824 and about the circumference of the connector body 821. The retention flange 829 includes a retention surface 830 (see FIG. 16) that faces in a rearward direction such that the retention surface 830 faces outwardly from the hybrid adapter 836 when the hybrid connector 820 is being inserted therein. The retention flange 829 defines side notches 831 which are formed by gaps in the retention flange 829. Ramps 832 can be provided at the side notches 831.

As indicated above, the hybrid connector 820 can be configured to provide both fiber optic and electrical conductivity. In this regard, ferrules 833 supporting the optical fibers 812 of the hybrid cable 811 can be mounted within the cylindrical front sleeves 825. In certain examples, one ferrule 833 can be mounted within each of the front sleeves 825. In certain examples, the ferrules 833 can be spring-biased in a forward direction relative to the connector body 821. The hybrid connector 820 also includes connector electrical contacts 834 having partial cylinders 835 that

mount over the front sleeves **825**. The connector electrical contacts **834** also include rear tails **837** that extend rearwardly through the connector body **821**. The rear tails **837** are adapted to be electrically connected to the electrical conductors **813** of the hybrid cable **811**.

The hybrid connector **820** can also include a rear housing **838** that mounts to the rear end **823** of the connector body **821** by means such as a snap-fit connection or other connection technique. The rear housing **838** includes two mating half-pieces **838a**, **838b** that mount to the rear end **823** of the connector body **821**. In certain examples, forward portions **839** of the half-pieces **838a**, **838b** can fit inside the rear end **823** of the connector body **821**. Tabs **840** of the rear housing **838** can snap within corresponding openings **841** of the connector body **821** to retain the rear housing **838** in place relative to the connector body **821**. The rear housing **838** can define an interior receptacle **842** having an elongate transverse cross-section sized to receive a jacketed end of the hybrid cable **811**. The rear housing **838** can define a central opening **843** for routing the optical fibers **812** from the hybrid cable **811** to the interior of the connector body **821** for termination at the ferrules **833**. The forward portions **839** of the half-pieces **838a**, **838b** can define openings such as slits **844** for receiving the rear tails **837** of the connector electrical contacts **834**. In this way, the rear tails **837** can extend into the receptacle **842** of the rear housing **838** to facilitate making electrical contact with the connector electrical conductors **813** of the hybrid cable **811**.

In certain examples, the hybrid connector **820** can include an outer sleeve **845** that fits over the exterior of the hybrid cable **811** and also fits over the exteriors of the rear housing **838** and the connector body **821**. In certain examples, the outer sleeve **845** can provide a sealed interface between the outer jacket of the hybrid cable **811** and the exterior of the hybrid connector **820**. In certain examples, the outer sleeve **845** extends forwardly generally to the retention surface **830** of the retention flange **829**. In one example embodiment, the outer sleeve **845** can be a shape memory material such as a heat-shrink tube. In certain examples, adhesive can be provided within the outer sleeve **845** to facilitate sealing and retention. It will be appreciated that the outer sleeve **845** can function to assist in securing the rear housing **838** to the connector body **821**. The outer sleeve **845** can also provide a retention function for assisting in axially securing the hybrid cable **811** to the hybrid connector **820**.

Referring to FIG. 18, the connector body **821** has an elongate transverse cross-sectional shape that is elongated so as to be longer along a major axis **M3** as compared to along a minor axis **M4**. In certain examples, connector body **821** defines a width **W2** along the major axis **M3** that is longer than a height **H2** defined along the minor axis **M4**. As shown at FIG. 18, ferrules **833** are aligned along the major axis **M3**. Also, the side notches **831** are positioned on opposite sides of the major axis **M3**. The connector body **821** has major sides **846** positioned on opposite sides of the major axis **M3** and minor sides **847** positioned on opposite sides of the minor axis **M4**. The side notches **831** are provided at the major sides **846**. The minor sides **847** define rounded ends of the elongate transverse cross-sectional shape of the connector body **821**.

Referring to FIG. 19, the hybrid adapter **836** is configured to mount within the port **814** of the structure **815**. The hybrid adapter **836** includes an adapter housing **850** defined by an outer part **851** and an inner part **852**. In the depicted example, the outer part **851** defines a port **853** sized for receiving the hybrid connector **820** and the inner part **852** defines one or more ports **854** (see FIG. 21) for receiving

fiber optic connectors (e.g., LC connectors, duplex LC connectors, SC connectors, or other types of connectors). The outer part **851** includes flexible extensions **856** having tabs **857** for retaining the outer part **851** within the port **814** by a snap-fit connection. The inner part **852** mounts between the extensions **856** and includes recesses **858** that receive tabs **859** of the outer part **851** to secure the parts **851**, **852** together. Adapter electrical contacts **860** mount at an outer end of the inner part **852**. In certain examples, the adapter electrical contacts **860** mounted within the interior of the inner part **852**. The adapter electrical contacts **860** can include C-shaped portions **862** for engaging the connector electrical contacts **834** and tabs **863** for allowing the adapter electrical contacts **860** to be electrically connected (e.g., wired) to an active component in need of power.

Referring to FIG. 20, the hybrid adapter **836** can include internal sleeves **864** positioned within the interior of the hybrid adapter **836**. The sleeves **864** can be configured to receive the ferrules **833** of the hybrid connector **820**. The sleeves **864** can also be configured to receive corresponding ferrules of the fiber optic connectors inserted within the ports **854** defined by the inner part **852**. In this way, sleeves **864** can be configured to optically connect the optical fibers of the hybrid connector **820** to corresponding optical fibers of the fiber optic connectors mated with the ports **854** of the inner part **852**. It will be appreciated that the ferrules **833** can fit inside the sleeves **864** and the front sleeves **825** of the connector body **821** may slide over the sleeves **864** of the hybrid adapter **836**. The C-shaped portions **862** of the adapter electrical contacts **860** are positioned such that ends of the C-shaped portions **862** are positioned on opposite sides of the sleeves **864**. In this way, when the hybrid connector **820** is inserted within the hybrid adapter **836**, the C-shaped portions **862** flex apart and make gripping contact with the connector electrical contacts **834**.

Referring still to FIG. 20, the hybrid adapter **836** defines a connector insertion axis **866** that extends through the hybrid adapter **836**. When the hybrid connector **820** is inserted into the hybrid adapter **836**, the longitudinal axis **824** of the hybrid connector **820** coaxially aligns with the connector insertion axis **866** of the hybrid adapter **836**.

In certain examples, the width **W2** of the transverse cross-sectional shape of the connector body **821** can be less than 2 centimeters and the height **H2** of the transverse cross-sectional shape of the connector body **821** can be less than 1.5 centimeters.

Referring back to FIG. 19, the connection system **810** can include a robust active coupler for securely retaining the hybrid connector **820** within the hybrid adapter **836**. In certain examples, robust active coupler is configured to retain the connector body **821** within the port **853** of the hybrid adapter **836** so as to withstand a pull-out force of at least 25 pounds. In other examples, robust active coupler is configured to retain the connector body **821** within the port **853** of the hybrid adapter **836** to withstand a pull-out force of at least 50 pounds.

Referring to FIG. 19, one example of a robust active coupler is shown as a slide clip **868**. The slide clip **868** integrated as part of the hybrid adapter **836** and is not carried with the hybrid connector **820**. This allows the hybrid connector **820** to maintain a relatively small transverse cross-sectional profile. The slide clip **868** is slidably mounted to an outer end of the outer part **851**. For example, the slide clip **868** includes rails **869** that slide within corresponding channels **870** defined by the outer part **851** of the hybrid adapter **836**. The slide clip **868** defines an opening **872** for receiving the hybrid connector **820** when the hybrid

connector is inserted into the hybrid adapter **836**. The opening **872** is elongated and has a matching transverse cross-sectional shape with the connector body **821**. As shown at FIG. 20, the slide clip **868** includes a release tab **874** that is intersected by a reference plane **875** that includes the connector insertion axis **866** as well as a major axis of the opening **872**. The slide clip **868** includes retention structures **876** positioned on opposite sides of the reference plane **875**. The retention structures **876** are positioned at major sides of the opening **872**. Each of the retention structures **876** includes a ramp **877** that faces at least partially in an outward direction. Each of the retention structures **876** also includes a retention surface **878** (see FIG. 21) that faces in an inward direction.

The slide clip **868** is movable relative to the adapter housing **850** between a coupling position and a non-coupling position. The slide clip **868** slides along the channels **870** of the hybrid adapter **836** when moving between the coupling position and the non-coupling position. It will be appreciated that the direction of movement of the slide clip **868** between the coupling position and the non-coupling position is generally transverse relative to the connector insertion axis **866**. The slide clip **868** is configured to retain the connector body **821** within the port **853** of the hybrid adapter **836** when in the coupling position. The slide clip **868** is configured to allow the connector body **821** to be removed from the port **853** of the hybrid adapter **836** when in the non-coupling position.

In certain examples, the hybrid adapter **836** can be configured to bias the slide clip **868** toward the coupling position. For example, referring to FIG. 19, the hybrid adapter **836** includes a spring such as a leaf spring **880** that is configured to bias the slide clip **868** toward the coupling position. The leaf spring **880** mounts within an elongate pocket **881** defined within the release tab **874**. The outer part **851** of the adapter housing **850** includes a spring reaction structure **882** that cooperates with the leaf spring **880** to bias the slide clip **868** toward the coupling position. Referring to FIG. 19, the slide clip **868** is loaded into the outer part **851** of the adapter housing **850** by inserting the clip **868** upwardly such that the rails **869** are received within the channels **870**. The slide clip **868** is then slid upwardly until the release tab **874** is positioned above the outer part **851** of the adapter housing **850**. It will be appreciated that the slide clip **868** includes a slot **883** for allowing the spring reaction structure **882** to pass through the slide clip **868** as the slide clip is moved upwardly. Once the release tab **874** is positioned higher than the spring reaction structure **882**, the leaf spring **880** is slid into the elongate retention pocket **881**. As so positioned, a free end of the leaf spring **880** is positioned directly over the spring reaction structure **882**. In this way, contact between the spring reaction structure **882** and the spring **880** prevents the slide clip **868** from being removed downwardly from the adapter housing **850**. The spring reaction structure **882** has an angled top surface **884** that opposes the underside of the leaf spring **880**. A peak **885** of the angled top surface **884** contacts the leaf spring **880**. The angled configuration of the angle top surface **884** provides clearance for allowing the leaf spring **880** to flex as the release tab **874** is manually depressed downwardly to move the slide clip **868** from the coupling position to the non-coupling position. Once the release tab **874** is released, the elasticity of the leaf spring **880** causes the slide clip **868** to return to the coupling position from the non-coupling position.

To provide secure retention of the hybrid connector **820** within the hybrid adapter **836**, the retention structures **876** of

the slide clip **868** are adapted to engage the connector body **821** on opposite sides of the connector body **821**. For example, in the depicted embodiment, the retention structures **876** engage the connector body **821** on both of the major sides **846** of the connector body **821**. Thus, the retention structures **876** engage the connector body **821** on opposite sides of the major axis **[M1]** *M3*.

To mate the hybrid connector **820** with the hybrid adapter **836**, the hybrid connector **820** is oriented such that the longitudinal axis **824** of the hybrid connector **820** coaxially aligns with the connector insertion axis **866** of the hybrid adapter **836** (see FIGS. 20 and 21). As so positioned, the side notches **831** provided at the major sides **846** of the connector body **821** align with the retention structures **876** provided at the major sides of the opening **872** of the slide clip **868**. The hybrid connector **820** is then inserted axially along the connector insertion axis **866** into the hybrid adapter **836**. As the hybrid connector **820** is inserted into the hybrid adapter **836**, the ramps **832** at the side notches **831** of the hybrid connector **820** engage the ramps **877** of the retention structures **876** of the hybrid adapter **836** (see FIG. 22). Contact between the ramps **832**, **877** as the hybrid connector **820** is continued to be inserted into the hybrid adapter **836** causes the slide clip **868** to move from the coupling position (see FIG. 22) to the non-coupling position (see FIG. 23). Inward insertion of the hybrid connector **820** continues until the retention surface **830** of the retention flange **829** of the hybrid connector **820** moves inwardly past the retention surfaces **878** at inner ends of the retention structures **876**. When this occurs, the spring **880** biases the spring clip **868** back to the coupling position as shown at FIG. 24.

With the hybrid connector **820** fully inserted within the hybrid adapter **836** and the slide clip **868** in the coupling position, the retention surfaces **830** defined by the retention flange **829** at the major sides **[848]** *846* of the connector body **821** are opposed by the retention surfaces **878** of the retention structures **876** of the slide clip **868**. In this way, interference between the retention surfaces **830**, **878** prevent the hybrid connector **820** from being withdrawn from the hybrid adapter **836**. With the hybrid connector **820** fully inserted within the hybrid adapter **836**, the ferrules **833** are received within the sleeves **864** of the hybrid adapter **836**, the front sleeves **825** of the hybrid connector **820** fit over the sleeves **864** of the hybrid adapter **836**, and the adapter electrical contacts **860** engage the conductor electrical contacts **834**.

To remove the hybrid connector **820** from the hybrid adapter **836**, the release tab **874** is manually depressed as shown at FIG. 25 to move the slide clip **868** from the coupling position to the non-coupling position. Once the slide clip **868** has been depressed to the non-coupling position, the hybrid connector **820** can be axially withdrawn from the hybrid adapter **836**.

Aspects of the present disclosure relate to hybrid connection systems that facilitate the fast, low cost and simple deployment of optical fiber and electrical power to interface with active devices. In certain examples, the hybrid connectivity system can provide power and optical signals to active devices in a local area network (LAN). In certain examples, the active devices can include optical network terminals (ONT) within a building. The ONTs can be located at or near desktop locations. The ONTs can include circuitry for providing optical-to-electrical and electrical-to-optical signal conversion. The ONTs can be coupled to active devices such as computing devices. In other examples, the active devices can include devices for generating wireless communication coverage areas (e.g., wireless transceivers) and other active

devices (e.g., cameras, computing devices, monitors, etc.). In still other examples, systems in accordance with the principles of the present disclosure can provide power and fiber optics to a power-over-Ethernet extender. The power-over-Ethernet extender can include optical-to-electrical conversion circuitry for converting optical signals to electric signals that are transmitted through copper cabling such as twisted pair cabling. Electrical power provided to the power-over-Ethernet extender can be directed over the twisted pair cabling to provide power in a power-over-Ethernet format.

While aspects of the present disclosure have been shown used with hybrid connection systems, it will be appreciated that the various aspects are also applicable to non-hybrid fiber optic connection systems and non-hybrid electrical connection systems

Various modifications and alterations of this disclosure may become apparent to those skilled in the art without departing from the scope and spirit of this disclosure, and it should be understood that the scope of this disclosure is not to be unduly limited to the illustrative examples set forth herein.

PARTS LIST

10 A system
 11 Base location
 12a-f Equipment
 14 Structure
 16 Central office
 18 Multi-fiber optical trunk cable
 20 Hybrid cable
 22 Transceivers
 24 Radio Tower
 100 Outer jacket
 102 Major axis
 104 Minor axis
 106 Left portion
 108 Right portion
 110 Central portion
 112 Left passage
 114 Right passage
 116 Central passage
 118 Central longitudinal axis
 120 Left electrical conductor
 122 Right electrical conductor
 124 Optical fiber
 126 Left pre-defined tear location
 128 Right pre-defined tear location
 130 Top side
 132 Bottom side
 134 Upper slit
 136 Lower slit
 138 Non-slitted portion
 140 Jacket weakening members
 142a-b Tensile strength structure
 144 [Longitudinal edges/ends] *Gap*
 620 [Fiber optical] *Hybrid* connector
 624 Electrical contacts
 626 Connector body
 627 Major sides
 628 Cylindrical sleeves
 629 Minor sides
 630 Intermediate structure
 632 Key feature
 634 First peripheral groove
 636 Second peripheral groove
 638 Adapter

640 Receptacle
 642 Receptacle
 644 Alignment sleeves
 646 Locking element
 5 648 Flange
 650 Latch
 652 Electrical contacts
 654 Internal portions
 656 External portions
 10 658 First piece
 660 Second piece
 [719 Connector body
 720 Connector
 721 Adapter
 15 722 Ferrules
 723 Shutters
 725 Electrical contacts
 746 Slide clip
 770 Ramp structures for moving shutters]
 20 810 Connection system
 811 Hybrid cable
 812 Optical fibers
 813 [Connector electrical contacts] *Electrical conductors*
 814 Port
 25 815 Structure forming enclosure
 820 Hybrid connector
 821 Connector body
 822 Front end
 823 Rear end
 30 824 Longitudinal axis of connector
 825 Front sleeves
 826 Key structure
 827 Peripheral groove
 828 Seal
 35 829 Retention flange
 830 Retention surface
 831 Side notches
 832 Ramps
 833 Ferrules
 40 834 Adapter electrical contacts
 835 Partial cylinder
 836 Hybrid adapter
 820 Hybrid connector
 [838 Rear housing]
 45 839 Forward portions
 840 Tabs
 841 Opening
 842 Receptacle
 843 Central opening
 50 844 Slits
 845 Outer sleeve
 846 Major sides
 847 Minor sides
 850 Adapter housing
 55 851 Outer part
 852 Inner part
 853 Outer port of adapter
 854 Inner ports of adapter
 856 Extensions
 60 857 Tabs
 858 Recess
 859 Tabs
 860 Adapter electrical contacts
 862 C-shaped portions
 65 863 Tabs
 864 Sleeves
 866 Connector insertion axis

868 Slide clip
 869 Rails
 870 Channels
 872 Opening
 874 Release tab
 875 Reference plane
 876 Retention structure
 877 Ramp
 878 Retention surface
 880 Leaf spring
 881 Elongate pocket
 882 Spring reaction structure
 883 Slot
 884 Angled top surface
 885 Peak

What is claimed is:

[1. A hybrid fiber optic connector comprising:

a connector body having a transverse cross-sectional shape, the connector body including two generally cylindrical sleeves at a front of the connector body, the two generally cylindrical sleeves each including a separate ferrule mounted therein;

electrical contacts that at least partially mount over the two generally cylindrical sleeves so as to be carried with the connector body; and

an adapter configured to mate with the connector body for optically coupling optical fibers supported by the connector body to responding optical fibers of other optical connectors, wherein the adapter defines a port for receiving the connector body;

wherein a robust active coupler is included with the adapter and not carried with the connector body, the robust active coupler being movable relative to the port of the adapter and being configured to retain the connector body within the port.]

[2. The hybrid fiber optic connector of claim 1, wherein the robust active coupler is a slide clip, the slide clip including a release tab that is intersected by a reference plane, the release tab being adapted to be manually depressed downwardly to move the slide clip from a coupling position to a non-coupling position.]

[3. The hybrid fiber optic connector of claim 1, wherein the electrical contacts are electrically conductive bands.]

[4. The hybrid fiber optic connector of claim 2, wherein the adapter includes a spring that mounts within an elongate pocket defined within the release tab, the spring being configured to bias the slide clip toward the coupling position.]

[5. The hybrid fiber optic connector of claim 4, wherein the spring flexes as the release tab is depressed downwardly to move the slide clip from the coupling position to the non-coupling position, when the release tab is released, the elasticity of the spring causes the slide clip to return to the coupling position from the non-coupling position.]

[6. The hybrid fiber optic connector of claim 2, wherein the slide clip includes rails that slide within corresponding channels defined by the adapter, and wherein the slide clip defines an opening for receiving the hybrid fiber optic connector when the hybrid fiber optic connector is inserted into the adapter.]

[7. The hybrid fiber optic connector of claim 6, wherein the slide clip includes retention structures positioned on opposite sides of the reference plane, the retention structures being positioned at major sides of the opening and the retention structures being adapted to engage the connector body on opposite major sides of the connector body.]

[8. The hybrid fiber optic connector of claim 7, wherein each of the retention structures includes a ramp that faces at least partially in an outward direction, and each of the retention structures also includes a retention surface that faces in an inward direction.]

[9. The hybrid fiber optic connector of claim 8, wherein when the hybrid fiber optic connector is inserted axially along a connector insertion axis into the adapter, ramps at side notches of the hybrid fiber optic connector engage the ramps of the retention structures of the adapter.]

[10. The hybrid fiber optic connector of claim 4, wherein the adapter includes a spring reaction structure that cooperates with the spring to bias the slide clip toward the coupling position.]

[11. The hybrid fiber optic connector of claim 10, wherein the slide clip includes a slot for allowing the spring reaction structure to pass through the slide clip as the slide clip is moved upwardly, wherein contact between the spring reaction structure and the spring prevents the slide clip from being removed downwardly from the adapter.]

[12. A fiber optic connection system comprising:

a connector body that supports at least one ferrule supporting at least one optical fiber;

a fiber optic adapter defining a port for receiving the connector body;

an environmental seal for providing a seal between the connector body and the fiber optic adapter; and

a robust active coupler included with the fiber optic adapter and not carried with the connector body, the robust active coupler being movable relative to the port of the fiber optic adapter and being configured to retain the connector body within the port, the robust active coupler being configured to retain the connector body within the port so as to withstand a pull-out force of at least 25 pounds;

wherein the robust active coupler is slidably movable between a coupling position and non-coupling position.]

[13. The fiber optic connection system of claim 12, wherein the robust active coupler engages the connector body at retention locations positioned at opposite sides of the connector body, the robust active coupler being configured to retain the connector body within the port when in the coupling position, and the robust active coupler being configured to allow removal of the connector body from the port when in the non-coupling position.]

[14. The fiber optic connection system of claim 13, wherein the robust active coupler is a slide clip, wherein the slide clip is spring biased toward the coupling position by a spring.]

[15. The fiber optic connection system of claim 12, wherein the connector body has a transverse cross-sectional shape, wherein the transverse cross-sectional shape of the connector body has a small form-factor with a maximum width less than 2 centimeters along the major axis and a maximum height less than 1.5 centimeters along a minor axis.]

[16. The fiber optic connection system of claim 14, further comprising a ramp arrangement for automatically moving the robust active coupler against the bias of the spring from the coupling position to the non-coupling position while the connector body is being inserted in the port, wherein the spring returns the robust active coupler to the coupling position once the connector body has been fully inserted in the port.]

21

[17. A fiber optic connection system comprising:

a connector body that supports at least two ferrules positioned along a major axis, the at least two ferrules each supporting at least one optical fiber;

a fiber optic adapter defining a port for receiving the connector body; and

a slide clip included with the fiber optic adapter and not carried with the connector body, the slide clip being movable relative to the port of the fiber optic adapter between a coupling position and non-coupling position, the slide clip being configured to retain the connector body within the port when in the coupling position, and the slide clip being configured to allow removal of the connector body from the port when in the non-coupling position;

wherein when the slide clip is in the coupling position, the slide clip engages the connector body at retention locations positioned at opposite sides of the connector body, and wherein the slide clip is spring biased toward the coupling position by a spring.]

[18. The fiber optic connection system of claim 17, wherein a transverse cross-sectional shape of the connector body has a small form-factor with a maximum width less than 2 centimeters along the major axis and a maximum height less than 1.5 centimeters along a minor axis.]

[19. The fiber optic connection system of claim 17, further comprising a ramp arrangement for automatically moving the slide clip against the bias of the spring from the coupling position to the non-coupling position while the connector body is being inserted in the port, wherein the spring returns the spring clip to the coupling position once the connector body has been fully inserted in the port.]

20. A fiber optic connection system comprising:

a fiber optic connector including at least one ferrule supporting at least one optical fiber;

a housing defining a port for receiving the fiber optic connector;

an environmental seal for providing a seal around the fiber optic connector within the port;

a ferrule alignment sleeve for receiving the ferrule when the fiber optic connector is inserted in the port;

a robust active coupler carried by the housing and not carried with the fiber optic connector, the robust active coupler being movable relative to the port and being configured to retain the fiber optic connector within the port, the robust active coupler being configured to retain the fiber optic connector within the port so as to withstand a pull-out force of at least 25 pounds;

wherein the robust active coupler is slidably movable between a coupling position and a non-coupling position, wherein the robust active coupler is spring biased toward the coupling position, wherein the robust active coupler is pressed to move the robust active coupler against the spring bias from the coupling position to the non-coupling position, and

a ramp arrangement for automatically moving the robust active coupler against the spring bias from the coupling position to the non-coupling position when the fiber optic connector is being inserted into the port, wherein the spring bias returns the robust active coupler to the coupling position once the fiber optic connector has been fully inserted into the port.

21. The fiber optic connection system of claim 20, wherein the fiber optic connector is insertable into the port along a connector insertion axis, wherein the robust active coupler defines a connector opening for receiving the fiber optic

22

connector, and wherein the connector opening has a matching transverse cross-sectional shape with the fiber optic connector.

22. The fiber optic connection system of claim 21, wherein the ramp arrangement includes at least one ramp positioned at the connector opening of the robust active coupler.

23. A fiber optic connection system comprising:

a fiber optic connector including at least one ferrule supporting at least one optical fiber;

a housing defining a port for receiving the fiber optic connector;

an environmental seal for providing a seal around the fiber optic connector within the port;

a ferrule alignment sleeve for receiving the ferrule when the fiber optic connector is inserted in the port;

a robust active coupler carried by the housing and not carried with the fiber optic connector, the robust active coupler being movable relative to the port and being configured to retain the fiber optic connector within the port, the robust active coupler being configured to retain the fiber optic connector within the port so as to withstand a pull-out force of at least 25 pounds;

wherein the robust active coupler is slidably movable between a coupling position and a non-coupling position, wherein the robust active coupler is spring biased toward the coupling position, wherein the robust active coupler includes a release tab that is pressed to move the robust active coupler against the spring bias from the coupling position to the non-coupling position, and

a ramp arrangement for automatically moving the robust active coupler against the spring bias from the coupling position to the non-coupling position when the fiber optic connector is being inserted into the port, wherein the spring bias returns the robust active coupler to the coupling position once the fiber optic connector has been fully inserted into the port, and wherein the ramp arrangement includes at least one ramp positioned at the connector opening of the robust active coupler.

24. A fiber optic connection system comprising:

a fiber optic connector including at least one ferrule supporting at least one optical fiber;

a housing defining a port for receiving the fiber optic connector;

an environmental seal for providing a seal around the fiber optic connector within the port;

a ferrule alignment sleeve for receiving the ferrule when the fiber optic connector is inserted in the port;

a robust active coupler carried by the housing and not carried with the fiber optic connector, the robust active coupler being movable relative to the port and being configured to retain the fiber optic connector within the port, the robust active coupler being configured to retain the fiber optic connector within the port so as to withstand a pull-out force of at least 25 pounds;

wherein the robust active coupler is slidably movable between a coupling position and a non-coupling position, wherein the robust active coupler is spring biased toward the coupling position, and

a ramp arrangement for automatically moving the robust active coupler against the spring bias from the coupling position to the non-coupling position when the fiber optic connector is being inserted into the port, wherein the spring bias returns the robust active coupler to the coupling position once the fiber optic connector has been fully inserted into the port.

25. The fiber optic connection system of claim 24, wherein the fiber optic connector is insertable into the port along a

connector insertion axis, wherein the robust active coupler defines a connector opening for receiving the fiber optic connector, and wherein the connector opening has a matching transverse cross-sectional shape with the fiber optic connector.

5

26. The fiber optic connection system of claim 25, wherein the ramp arrangement includes at least one ramp positioned at the connector opening of the robust active coupler.

* * * * *