



INTERNATIONAL APPLICATION PUBLISHED UNDER THE PATENT COOPERATION TREATY (PCT)

(51) International Patent Classification ⁶ : A47K 10/32	A1	(11) International Publication Number: WO 99/55213 (43) International Publication Date: 4 November 1999 (04.11.99)
<p>(21) International Application Number: PCT/IB99/00738</p> <p>(22) International Filing Date: 23 April 1999 (23.04.99)</p> <p>(30) Priority Data: 98870094.4 28 April 1998 (28.04.98) EP</p> <p>(71) Applicant (for all designated States except US): THE PROCTER & GAMBLE COMPANY [US/US]; One Procter & Gamble Plaza, Cincinnati, OH 45202 (US).</p> <p>(72) Inventor; and (75) Inventor/Applicant (for US only): TACK, Joris, Jozef, Gustaaf [BE/IT]; Via Male, 73, I-00124 Rome (IT).</p> <p>(74) Agents: REED, T., David et al.; The Procter & Gamble Company, 5299 Spring Grove Avenue, Cincinnati, OH 45217-1087 (US).</p>	<p>(81) Designated States: AE, AL, AM, AT, AT (Utility model), AU, AZ, BA, BB, BG, BR, BY, CA, CH, CN, CU, CZ, CZ (Utility model), DE, DE (Utility model), DK, DK (Utility model), EE, EE (Utility model), ES, FI, FI (Utility model), GB, GD, GE, GH, GM, HR, HU, ID, IL, IN, IS, JP, KE, KG, KP, KR, KZ, LC, LK, LR, LS, LT, LU, LV, MD, MG, MK, MN, MW, MX, NO, NZ, PL, PT, RO, RU, SD, SE, SG, SI, SK, SK (Utility model), SL, TJ, TM, TR, TT, UA, UG, US, UZ, VN, YU, ZA, ZW, ARIPO patent (GH, GM, KE, LS, MW, SD, SL, SZ, UG, ZW), Eurasian patent (AM, AZ, BY, KG, KZ, MD, RU, TJ, TM), European patent (AT, BE, CH, CY, DE, DK, ES, FI, FR, GB, GR, IE, IT, LU, MC, NL, PT, SE), OAPI patent (BF, BJ, CF, CG, CI, CM, GA, GN, GW, ML, MR, NE, SN, TD, TG).</p> <p>Published <i>With international search report.</i></p>	

(54) Title: A CONTAINER

(57) Abstract

A container (1), preferably a container containing wetted tissues comprising a container body (10) and a lid (11), said lid comprising a stationary lid member (13) and a movable lid member (14). The container comprises at least one elastically deformable strip (15) that extends from the outer side of the movable lid member to the outer side of the stationary lid member. Moreover, the container also preferably features a releasable locking mechanism (25) for securing the movable lid member into the close position, or releasing it by a single finger push into the open position. Furthermore, and since the movable lid member is hingedly connected to the stationary lid member, each hinge housing of the stationary lid member preferably features an angle in its back side to control and fix the opening angle of the movable lid member. Finally, in case the wipes are to be dispensed from a roll, the lid preferably features a slit opening so that the user can dispense a desired length for a wipe and cut it from the rest of the roll.

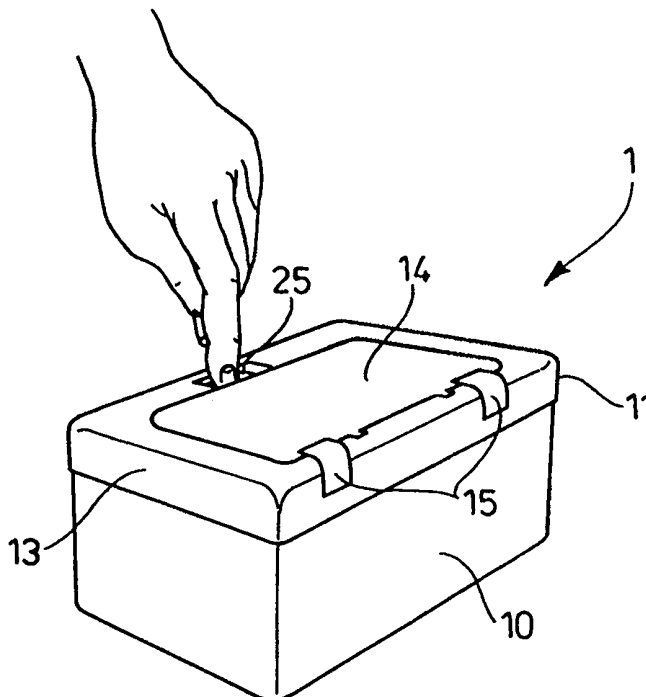

FOR THE PURPOSES OF INFORMATION ONLY

Codes used to identify States party to the PCT on the front pages of pamphlets publishing international applications under the PCT.

AL	Albania	ES	Spain	LS	Lesotho	SI	Slovenia
AM	Armenia	FI	Finland	LT	Lithuania	SK	Slovakia
AT	Austria	FR	France	LU	Luxembourg	SN	Senegal
AU	Australia	GA	Gabon	LV	Latvia	SZ	Swaziland
AZ	Azerbaijan	GB	United Kingdom	MC	Monaco	TD	Chad
BA	Bosnia and Herzegovina	GE	Georgia	MD	Republic of Moldova	TG	Togo
BB	Barbados	GH	Ghana	MG	Madagascar	TJ	Tajikistan
BE	Belgium	GN	Guinea	MK	The former Yugoslav Republic of Macedonia	TM	Turkmenistan
BF	Burkina Faso	GR	Greece	ML	Mali	TR	Turkey
BG	Bulgaria	HU	Hungary	MN	Mongolia	TT	Trinidad and Tobago
BJ	Benin	IE	Ireland	MR	Mauritania	UA	Ukraine
BR	Brazil	IL	Israel	MW	Malawi	UG	Uganda
BY	Belarus	IS	Iceland	MX	Mexico	US	United States of America
CA	Canada	IT	Italy	NE	Niger	UZ	Uzbekistan
CF	Central African Republic	JP	Japan	NL	Netherlands	VN	Viet Nam
CG	Congo	KE	Kenya	NO	Norway	YU	Yugoslavia
CH	Switzerland	KG	Kyrgyzstan	NZ	New Zealand	ZW	Zimbabwe
CI	Côte d'Ivoire	KP	Democratic People's Republic of Korea	PL	Poland		
CM	Cameroon	KR	Republic of Korea	PT	Portugal		
CN	China	KZ	Kazakstan	RO	Romania		
CU	Cuba	LC	Saint Lucia	RU	Russian Federation		
CZ	Czech Republic	LI	Liechtenstein	SD	Sudan		
DE	Germany	LK	Sri Lanka	SE	Sweden		
DK	Denmark	LR	Liberia	SG	Singapore		
EE	Estonia						

A CONTAINER

Field of the invention

The present invention generally relates to a container with a spring open mechanism, preferably to a container for wetted tissues.

Background of the invention

Containers for wetted tissues are the most representative of containers for consumer products to which the present invention applies; such containers typically comprise, for example, a body of the container constructed so that wetted tissues for house-cleaning and/or personal cleaning purposes can be picked out one by one, either from a stack of wetted tissues or from a roll packed therein, and a lid adapted to fit on the body to close its upper opening. This lid usually comprises a stationary lid member directly fitting on the upper opening of the container body and a movable lid member having its base end hinged to one side end of an opening, or dispensing device, formed in a central zone of the stationary lid member, through which the wetted tissues will be picked out one by one. Furthermore, these containers typically comprise a spring open mechanism that is achieved by using a releasable locking mechanism combined to a spring means that is usually made out of rubber.

The following references are directed to containers for wetted tissues comprising a lid and a dispensing device: European Patent Application n° EP-0-748 748 A1, Uni-charm Corporation, publication date: 18 dec. 1996 which discloses a container for wetted tissues comprising a container body, a movable lid member which is hinged to a stationary lid member. An elastic strip is provided, combined to a releasable lock for automatic opening of the package; European Patent

Application EP-0-629 560 A3, Kao Corp., published 21-12-1994 which describes a cap with a hinged top lid, which are attached through a hinge. A rubber like elastic member is provided on the cap body and/or the inner surface of the top lid such as to be elastically deformed between the cap body and the top lid, when the top lid is closed.

A main problem with the above mentioned inventions is that in some cases, the container is to be filled with wetted wipes that are usually moistened with a lotion comprising volatile chemicals and/or organic solvents. Then, there is a risk that these chemicals chemically react with the rubber and damage the spring very rapidly. In the above-cited executions of wipe containers, the spring system is positioned inside the cover, and as a result, is likely to be in contact with vapors of the lotion which is contained inside the container, and so, early damaged, then, losing their properties.

Thus, the present invention provides the user with a container preferably for wetted tissues, which comprises at least one elastically deformable strip that extends from the outer side of the movable lid member to the outer side of the stationary lid member, so as to create a spring open mechanism which is not sensitive to the container contents.

It is another object of the present invention to provide a container with a releasable locking mechanism to secure/release the movable lid member respectively in the close/open positions.

It is a further object of the present invention to provide a container with a means to control the opening angle of the movable lid member.

It is then another object of the present invention to provide the consumer with a container that comprises a means to facilitate the tearing and cutting operations of a wipe when it is dispensed from a roll.

Summary of the invention

The present invention is directed to a container, preferably to a container containing wetted tissues comprising a container body and a lid, said lid comprising a stationary lid member and a movable lid member, characterized in that the container comprises at least one elastically deformable strip that extends from the outer side of the movable lid member to the outer side of the stationary lid member. Moreover, the container also preferably features a releasable locking mechanism for securing the movable lid member into the close position, or releasing it by a single finger push into the open position. Furthermore, and since the movable lid member is hingeably connected to the stationary lid member, each hinge housing of the stationary lid member preferably features an angle in its back side to control and fix the opening angle of the movable lid member. Finally, in the case the wipes are to be dispensed from a roll, the lid preferably features a slit opening so that the user can dispense a desired length for a wipe and cut it from the rest of the roll.

Brief description of the drawings

The invention will now be explained in detail with reference to the accompanying drawings, in which:

- Figure 1 is a perspective view of the container in closed position with push button and elastic strips in stretched position.
- Figure 2 is a perspective view of the container in open position and rubber strips in relaxed position.
- Figure 3 is an enlarged view of the lid, showing one possibility to attach the rubber strip to the stationary and movable lids.
- Figure 4 shows the push button in close (A) and open (B) position via profile views.

- Figure 5 is a perspective and enlarged view showing the angle in back side of hinge housing to control/ fix the opening angle of the lid.
- Figure 6 is a perspective view of the container with partial lid to form a slit opening for dispensing/cutting of a sheet from a roll.
- Figure 7 is an enlarged profile view of a rubber strip, showing its thicker ends with retaining notches.

Detailed description of the invention

A container (1) comprises a lid member (11) that fits onto a container body (10), or is part of said container body (10). A stack of tissues, preferably a stack of wetted tissues is packed in to said container body (10). The tissues can be dispensed for example from a roll of tissues packed therein. Alternatively, they can be pop-up tissues, that is to say, they are inter-folded, for example in a zigzag folding pattern, such a pop-up system of tissue dispensing is well known in the art. Said container body (10), comprises an upper opening (12) That is closed by the lid member (11). Said lid member (11) comprises a stationary lid member (13) and a movable lid member (14) both made of any suitable synthetic resin material, for example polypropylene. The movable lid member (14) is hingeably attached to the stationary lid member (13), and both of them are moreover provided with at least one rubber-like strip (15) which is positioned on the outside of the container (1). A more detailed description of some embodiments of the present invention will now be made with reference to the accompanying figures.

As shown in figures 1, 2 and 6, the container (1) comprises a container body (10), with any suitable shape, such as for example a polygonal or rounded shape, but preferably a substantially rectangular parallelepipedic shape. Said container body (10) comprises side walls and an upper opening (12). It is made

out of any suitable thermoplastic polymer, such as, for example a polypropylene material or polyethylene, polystyrene, acrylonitril butadiene styrene, polyester, polyvinyl chloride, polycarbonate or elastomer, but preferably from a polypropylene material, which is preferably molded by an injection molding process. Optionally, the container body (10) can be made out of a transparent or semi-transparent plastic material, or it can be made out of a multi-injection molding process, so as to allow molding of different parts, out of different materials, at the same time.

In one embodiment of the present invention, the container body (10) comprises a second open side, preferably the bottom side, which is closed by a removable cover. Thus, when it is empty, the container can be refilled with a new stack or a new roll of tissues. Optionally but preferably, the bottom surface of the container (10) is greater than the top surface, so as to increase the stability of the container. Moreover and optionally, the removable cover is made out of a material whose flexibility is such as to increase the tightness between said removable cover and the container body.

In the second embodiment of the present invention, the lid member (11) can be molded as an integral part of the container body (10), and then preferably forms the upper side of said container body. It can also be a separate part which fits onto the container body (10), preferably at its top part.

The stationary lid member (13) comprises a top floor (16) with at least one opening (17) onto which the movable lid member (14) is attached and free to move hingeably. Said opening (17) has a surface comprised within the range of 5 to 90% of the stationary lid member surface.

In one preferred embodiment of the present invention, when the contents is wetted tissues that are to be removed one by one from the container (as shown in figure 2), the stationary lid member (13) comprises a dispensing means, which is either part of the stationary lid member (13), or a separate element which fits

onto said stationary lid member (13). This dispensing means comprises surfaces which are free of sharp angles, said surfaces forming a restricting channel through which the successive tissues are directed during use. In this case the tissues are folded (for example zigzag folded) in a manner which is well known by those skilled in the art. The dispensing means can also be a large opening in the stationary lid member through which tissues are taken from a flat stack of tissues.

In another embodiment of the present invention (shown in figure 6), particularly when the tissues are dispensed from a roll, the stationary lid member (13) comprises a slit opening (18) which is to be closed by a partial movable lid member (14). The slit opening (18) and the corresponding partial movable lid member (14) are preferably located in the front part of the lid (11), as shown in figure 6, along most of its length, so as to allow the user to dispense a tissue in its full width from a tissue roll which is contained inside. Moreover, the front edge of the partial movable lid member (14) can be used to block the tissue as soon as the desired length is achieved from the roll (from a perforated or non-perforated web). Additionally, said front edge of said partial movable lid member (14) preferably comprises a means (19), for example, a series of teeth or conic-shaped sharp profiles (see figure 6) that is to be used to facilitate the blocking of the tissue in its desired length and to cut the dispensed tissue from the roll.

The stationary lid member (13) further comprises at least one hinge housing (20) (see figure 5) into which the movable lid member (14) is hingeably positioned. This hinge housing (20) preferably features a back side (21) with an angle α that is used as a stop, so that the angle α at which the lid opens when unlocked, can be defined and controlled. The value of the angle α of the hinge housing (20) back side (21) can vary depending on the use which is made of the container. For tissues to be dispensed from the top of the container, the back side (21) angle of the hinge housing (20) is preferably within the range of 90° to 120°. In

case the container is to be attached on a wall, it is preferably within the range of 45-90°. In the case the tissue is to be dispensed from a roll, the angle is preferably comprised within the range of 20° to 45°.

Finally, the stationary lid member (13) comprises at least one attaching means (22) (see figure 3) onto which one end of the rubber strip (15) is to be attached. This attaching means (22) is preferably located in the rear side of the stationary lid member (13). In one preferred embodiment of the present invention, an axle (29) is positioned into a recess (30), and one end of the rubber strip (15) is mechanically attached onto this axle (29). In another embodiment, especially when the end parts of the rubber strips (15) are to be attached to the parts of the lid (11) by ultrasonic sealing or heat bonding, the attaching means (22) corresponds to the area, preferably recessed, of the stationary lid member (13) onto which the seal or heat bond is made.

The movable lid member (14) is hingeably attached onto the stationary lid member (13). It has preferably the shape of a plate and comprises pivot-like elements (see figure 5), that are to be rotateably fixed into the hinge housing (20) of the stationary lid member (13). Furthermore, it comprises at least one attaching means (22), preferably similar to the at least one which is located on the stationary lid member (13) (for example a recess (30) which contains an axle (29), or a simple area of the movable lid member (14) onto which one end of the rubber strip (15) is sealed by ultrasonic sealing or fixed by heat bonding), onto which another end of the rubber strip (15) is attached. This attaching means (22) is preferably located in the rear portion of the movable lid member (14), as shown in figures 1, 2 and 6.

In order to create an automatic opening, at least one rubber-like, or elastomeric, strip (15) is provided. This rubber strip (15) can have several possible shapes, provided that it allows to create an automatic opening of the movable lid

member (14) relatively to the stationary lid member (13). In one embodiment of the present invention, it is a rectangular band with both ends that are thicker than the central portion of the band (see figures 3 and 7).

In the case each attaching means (22) of the movable (14) and stationary (13) lid members comprises a recess (30) and an axle (29), each portion of the rubber strip (15) which is thicker has a length defined so that this thicker end (23) fits into the corresponding recess of the attaching means (22) of the stationary or movable lid member, as shown in figure 3, and moreover, each thicker end (23) of the rubber strip (15) has a corresponding attaching means, for example in the shape of a retaining notch (24) that fits onto the axle (29), as shown in figures 3 and 7. One thicker end (23) of this rubber strip (15) is fixed to the outside of the stationary lid member (13) and the other thicker end (23) is fixed to the outside of the movable lid member (14) (as shown in figure 3). The rubber strip (15) is attached in such a way that it is normally stretched (see figure 1) across the top rear edge of the container (1) when the movable lid member (14) is in the close position, and thus, charged with an elastic energy, and stays in a stretched condition until the movable lid member (14) has reached a complete open position, then it is relaxed as shown in figure 2. As previously described, in the embodiment of the present invention, where the tissues are to be dispensed from a roll, the movable lid member (14) is preferably located in the front part of the stationary lid member top side (see figure 6). Thus, in this particular case, the rubber strip (15) is not stretched across the rear angle of the container (1), as shown for example in figure 1, but it is stretched along the top surface of the stationary lid member (13) (see figure 6).

It is made out of natural or synthetic rubber or any other suitable material, so that it can be stretched and charged with sufficient potential elastic energy to create a spring open mechanism. For the fixing of the rubber strip (15) onto the attaching means (22) of said stationary and movable lid members, alternative

fixing techniques can be used such as ultrasonic sealing or heat clipping that are known by those skilled in the art.

In another embodiment of the present invention, it can also be molded at the same time the stationary and movable lid member (14) are molded, by using a multi-injection molding process. Such a process that is well known by those skilled in the art, presents the advantage to reduce the number of making operations, and thus the manufacturing cost of the package.

As shown in figures 1 and 4 (A & B), a releasable locking mechanism (25) is achieved by using a first means (26), for example a catch that fits onto another corresponding means (27) for example another catch, or a recess, one being located on the movable lid member (14), and the other being located on the stationary lid member (13), so that said locking mechanism (25) keeps the movable lid member (14) in the closed position when both means (26) and (27) are attached to one another. In one embodiment of the present invention, said locking mechanism (25) is directly released (see figure 4, A and B) by displacing a movable element, for example a push-button (28), onto which one means (26) or (27) is connected, thus disengaging said means from the other corresponding means. In another embodiment of the present invention, said locking mechanism (25) is indirectly released by applying an elastic deformation onto the lid (11) near to a movable element, for example a push-button (28), thus displacing said movable element, and then disengaging said means from the other corresponding means.

The combination between the rubber strip (15) and the releasable locking mechanism (25) constitutes a spring open mechanism: with a single finger push, the lid unlocks and pops-up completely in the open position, which preferably is defined by the angle in back side (21) of the hinge housing (20), thereby providing immediate access to the container contents, preferably through the dispensing opening which is located onto the stationary lid member (13).

Claims

1. A container (1) for containing tissues, preferably wetted tissues comprising a container body (10), a lid member (11) that fits onto, or is part of the container body (10), said lid member (11) comprising a stationary lid member (13) and a movable lid member (14), the movable lid member (14) being hingeably attached to the stationary lid member (13), characterized in that the container (1) comprises at least one elastically deformable strip (15) that extends from the outer side of the movable lid member (14) to the outer side of the stationary lid member (13).
2. A container (1) according to claim 1, wherein at least one elastically deformable strip (15) is stretched over the top rear edge of the container (1) when the movable lid member (14) is in the closed position, so that it is charged with an elastic energy.
3. A container (1) according to claims 1 and 2, wherein at least one elastically deformable strip (15) is attached to the stationary (13) and movable (14) lid members by using retaining notches (24) that fit onto corresponding axles (29).
4. A container (1) according to claims 1 and 2, wherein at least one elastically deformable strip (15) is attached to the stationary (13) and movable (14) lid members by using ultrasonic sealing.
5. A container (1) according to claims 1 and 2, wherein at least one elastically deformable strip (15) is attached to the stationary (13) and movable (14) lid members by using heat clipping.

6. A container (1) according to any of the preceding claims, wherein the stationary lid member (13) and/or the movable lid member (14) comprise means to provide a releasable locking mechanism (25) for securing the movable lid member (14) in the closed position, or releasing the movable lid member (14) charged with elastic energy into the open position, thus giving access to the container contents.
7. A container (1) according to claims 1 to 6, wherein the releasable locking mechanism (25) is composed of a catch that fits into a corresponding recess.
8. A container (1) according to any of the preceding claims, wherein the releasable locking mechanism (25) is directly released by displacing a movable element to which the catch is connected, thus disengaging the catch from the recess.
9. A container (1) according to claims 1 to 7, wherein the releasable locking mechanism (25) is indirectly released by applying an elastic deformation onto an area, the area being located near enough to the locking mechanism, to disengage the catch from the recess.
10. A container (1) according to any of the preceding claims, wherein the means by which the movable lid member (14) is pivotally attached to the stationary lid member (13), enables to control the angle at which the movable lid opens, and wherein the angle is comprised within the range of 20° to 120°.
11. A container (1) according to any of the preceding claims, wherein the movable lid member (14) comprises a series of teeth-like profiles to facilitate the tearing and cutting operations of a tissue from a roll.

12. A container (1) according to any of the preceding claims, which further comprises a re-fill opening located at the bottom side of the container (1) body (10), said re-fill opening being closed by a flexible removable cover.

Fig. 1

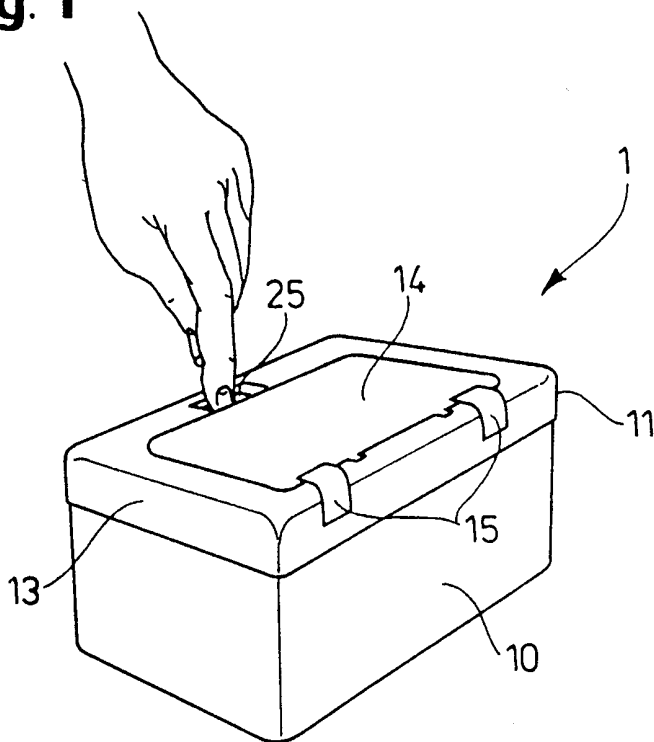

Fig. 2

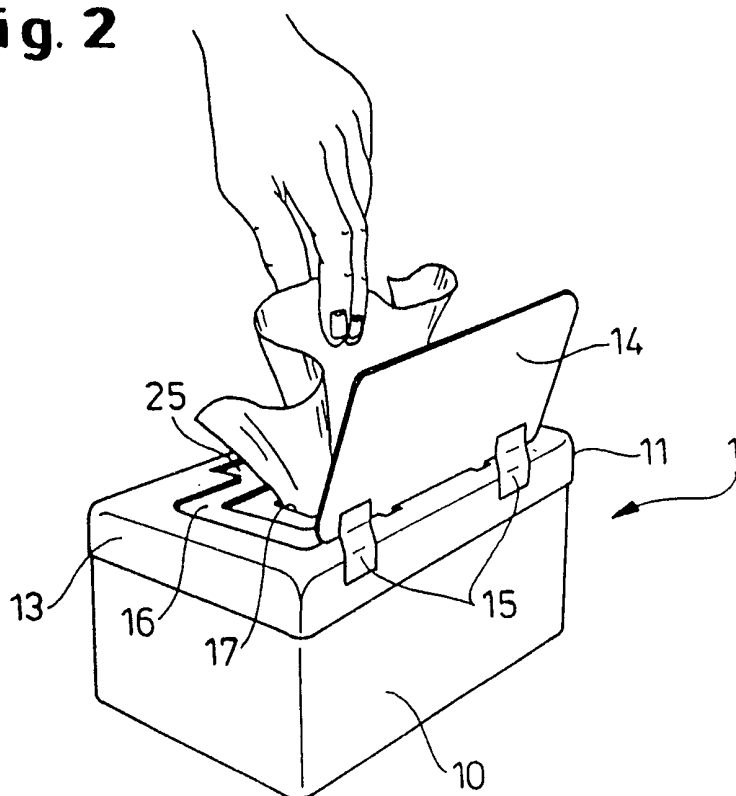

Fig. 3

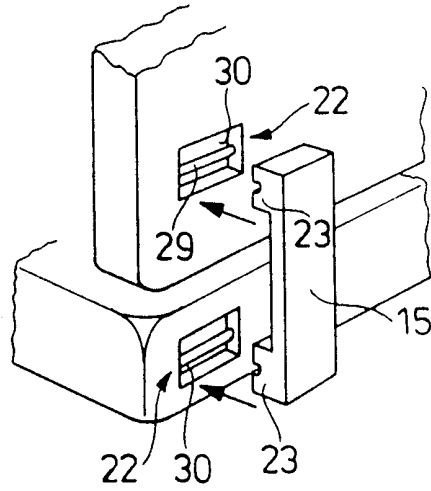

FIG. 4A

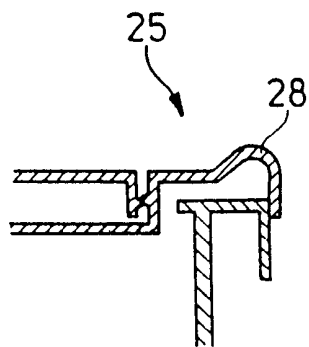

FIG. 4B

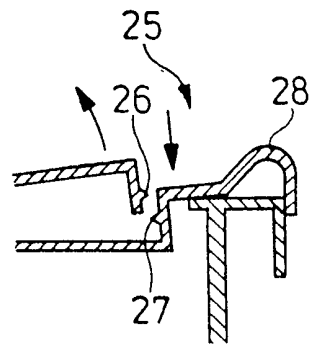

Fig. 5

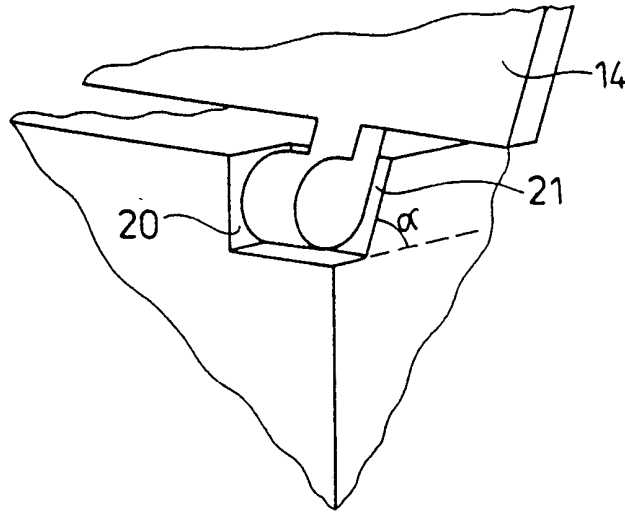

Fig. 6

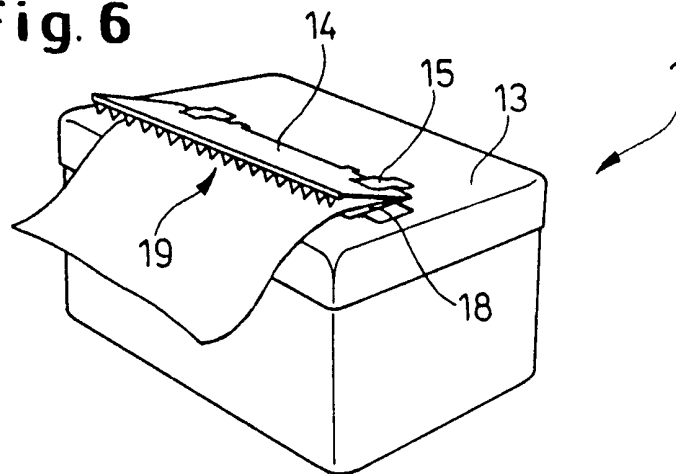
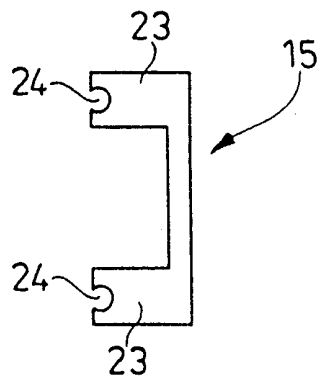

Fig. 7



INTERNATIONAL SEARCH REPORT

International Application No

PCT/IB 99/00738

A. CLASSIFICATION OF SUBJECT MATTER
IPC 6 A47K10/32

According to International Patent Classification (IPC) or to both national classification and IPC

B. FIELDS SEARCHED

Minimum documentation searched (classification system followed by classification symbols)
IPC 6 A47K

Documentation searched other than minimum documentation to the extent that such documents are included in the fields searched

Electronic data base consulted during the international search (name of data base and, where practical, search terms used)

C. DOCUMENTS CONSIDERED TO BE RELEVANT

Category °	Citation of document, with indication, where appropriate, of the relevant passages	Relevant to claim No.
X	US 3 967 756 A (BARISH ROBERT A) 6 July 1976 see the whole document ----	1,2,4,6, 7,9,10
X	US 3 994 417 A (BOEDECKER STEVEN M) 30 November 1976 see column 2, line 52 - column 4, line 2 see figures 1,3,4 ----	1,2,6,7, 9,10
X	DE 40 06 987 A (PENATEN GMBH) 12 September 1991 see the whole document ----	1,2,6,7, 9,10
X	DE 24 37 672 A (BOWATER SCOTT CORP) 20 February 1975 see page 4, paragraph 1 - page 5, paragraph 2; figures 1,2 ----- -/--	1,2



Further documents are listed in the continuation of box C.



Patent family members are listed in annex.

° Special categories of cited documents :

"A" document defining the general state of the art which is not considered to be of particular relevance

"E" earlier document but published on or after the international filing date

"L" document which may throw doubts on priority claim(s) or which is cited to establish the publication date of another citation or other special reason (as specified)

"O" document referring to an oral disclosure, use, exhibition or other means

"P" document published prior to the international filing date but later than the priority date claimed

"T" later document published after the international filing date or priority date and not in conflict with the application but cited to understand the principle or theory underlying the invention

"X" document of particular relevance; the claimed invention cannot be considered novel or cannot be considered to involve an inventive step when the document is taken alone

"Y" document of particular relevance; the claimed invention cannot be considered to involve an inventive step when the document is combined with one or more other such documents, such combination being obvious to a person skilled in the art.

"&" document member of the same patent family

Date of the actual completion of the international search

18 June 1999

Date of mailing of the international search report

01/07/1999

Name and mailing address of the ISA

European Patent Office, P.B. 5818 Patentlaan 2
NL - 2280 HV Rijswijk
Tel. (+31-70) 340-2040, Tx. 31 651 epo nl,
Fax: (+31-70) 340-3016

Authorized officer

Vrugt, S

INTERNATIONAL SEARCH REPORT

International Application No

PCT/IB 99/00738

C.(Continuation) DOCUMENTS CONSIDERED TO BE RELEVANT		
Category ³	Citation of document, with indication, where appropriate, of the relevant passages	Relevant to claim No.
A	WO 97 29025 A (BORDOY RIERA JUAN ;PERICH TOMAS FRANCISCO (ES); PROCTER & GAMBLE () 14 August 1997 see the whole document -----	1,3,6,7, 9,10

INTERNATIONAL SEARCH REPORT

information on patent family members

International Application No

PCT/IB 99/00738

Patent document cited in search report	Publication date	Patent family member(s)	Publication date
US 3967756 A	06-07-1976	NONE	
US 3994417 A	30-11-1976	AT 361177 B AT 399676 A AU 510987 B AU 1427776 A BE 842434 A BR 7603309 A CA 1039689 A CH 609857 A DE 2623976 A DK 240576 A FR 2313002 A GB 1545815 A GR 59907 A IE 42734 B JP 1248096 C JP 51148554 A JP 59020552 B NL 7605921 A PH 11841 A PT 65150 A, B SE 431819 B SE 7605897 A ZA 7602815 A	25-02-1981 15-07-1980 24-07-1980 01-12-1977 01-10-1976 15-02-1977 03-10-1978 30-03-1979 16-12-1976 03-12-1976 31-12-1976 16-05-1979 16-03-1978 08-10-1980 16-01-1985 20-12-1976 14-05-1984 06-12-1976 21-07-1978 01-06-1976 05-03-1984 03-12-1976 28-12-1977
DE 4006987 A	12-09-1991	DE 9007350 U	25-04-1991
DE 2437672 A	20-02-1975	GB 1476303 A BE 818553 A FR 2239972 A	10-06-1977 02-12-1974 07-03-1975
WO 9729025 A	14-08-1997	ES 1033201 U CA 2245698 A CN 1211957 A EP 0883555 A	01-08-1996 14-08-1997 24-03-1999 16-12-1998