

(19)
(12)

(KR)
(Y1)

(51) 。 Int. Cl. ⁷
E21C 37/00

(45)
(11)
(24)

2001 10 06
20 - 0232425
2001 05 17

(21) 20 - 2001 - 0004335
(22) 2001 02 20

(73) 171 - 6 106 - 506

(72) 171 - 6 106 - 506

203 - 302

(74)
:

가 :

(54)

(100) 가 (100)

(100) (110)가

4a

1 ,

2 1 ,

3 ,

4a 4d

* *

100 : , 102 : ,

110 : , 112 : .

(Chisel) , ,

	1	3		(10)	(12)
(18)	(14)	(14)	(14)	(16)	(18)

(14) (18)
가
가 .

	(14)	(18)		가
(18)	(14)	(18)	(12) (20)	(12)
	(2) ,	(12)		

가 .

가 가

가

가

4a

4d

12)	4a	(100)	(110)가	(110)가	(100)
(12)	(12)	(100)	가	(110)가	(110)가 (100)
(12)					(110)
					(100)

가	4b	(100)	4c	(100)	가	(104)가
	(110)가	(104)		(110)		(114) 가

106)	4d	(100)	(106)	(106)	(100)
	가	(120)	(122)가		(120)가

(RUBBER)

120) 가 (110,120) 가 (100) 가 (100) 가 (100) 가 (110,120)가 (100)

4a 4b 4d

(100) (104) (114) (104) (104)

(100) (102) (110,120)가 (100)

(110,120)가 (100) (12) (14) 4a

4d (100) (110,120) (110,120)가 (110,120) (122) (122) (110,120) (122) (110) (14) 가 가 가 가 (14) 가 (110,120) (122) (14) 가 (110,120)가 (12)

(100) 가 가 (110,120)가 (12)

가 가 가 가

가 가

1

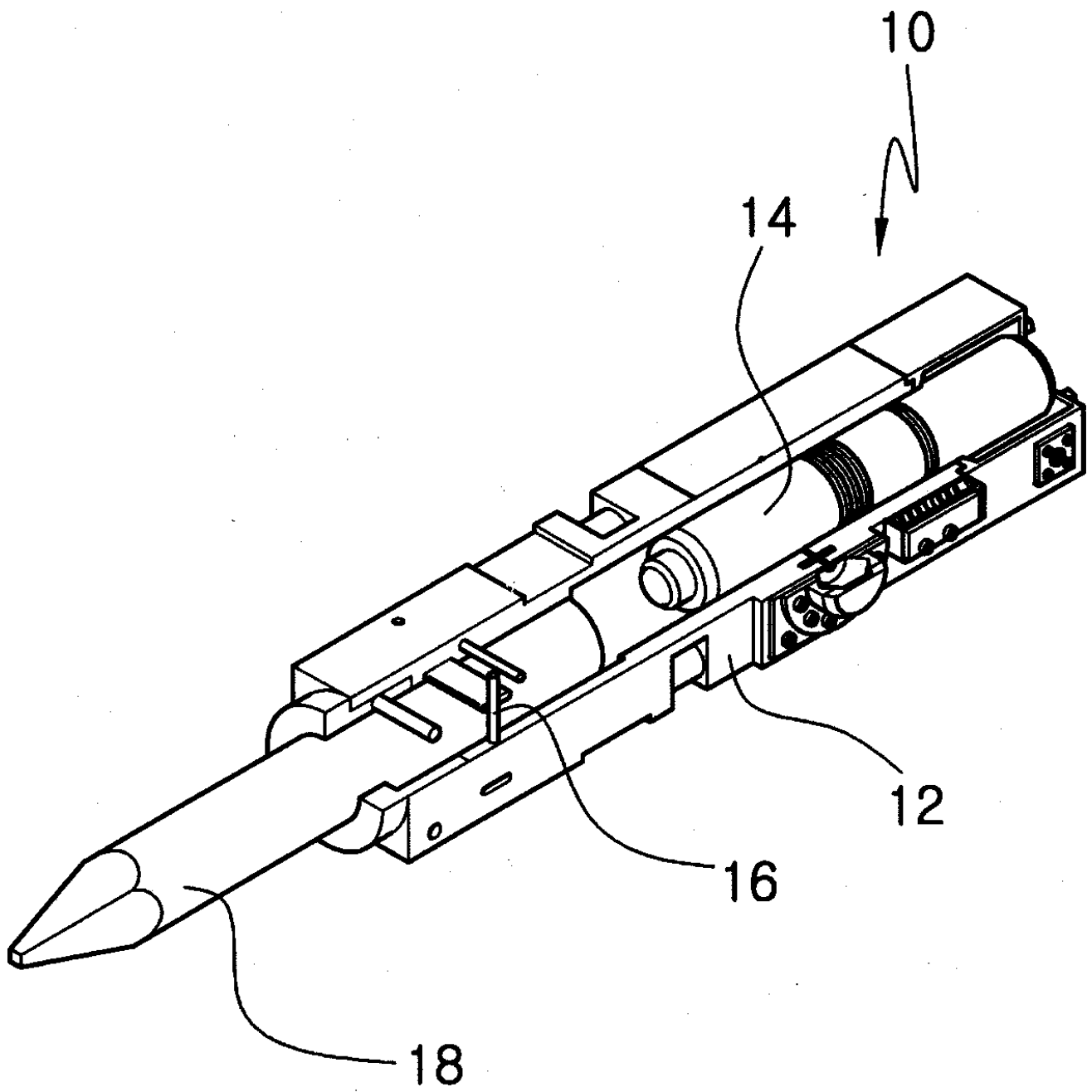

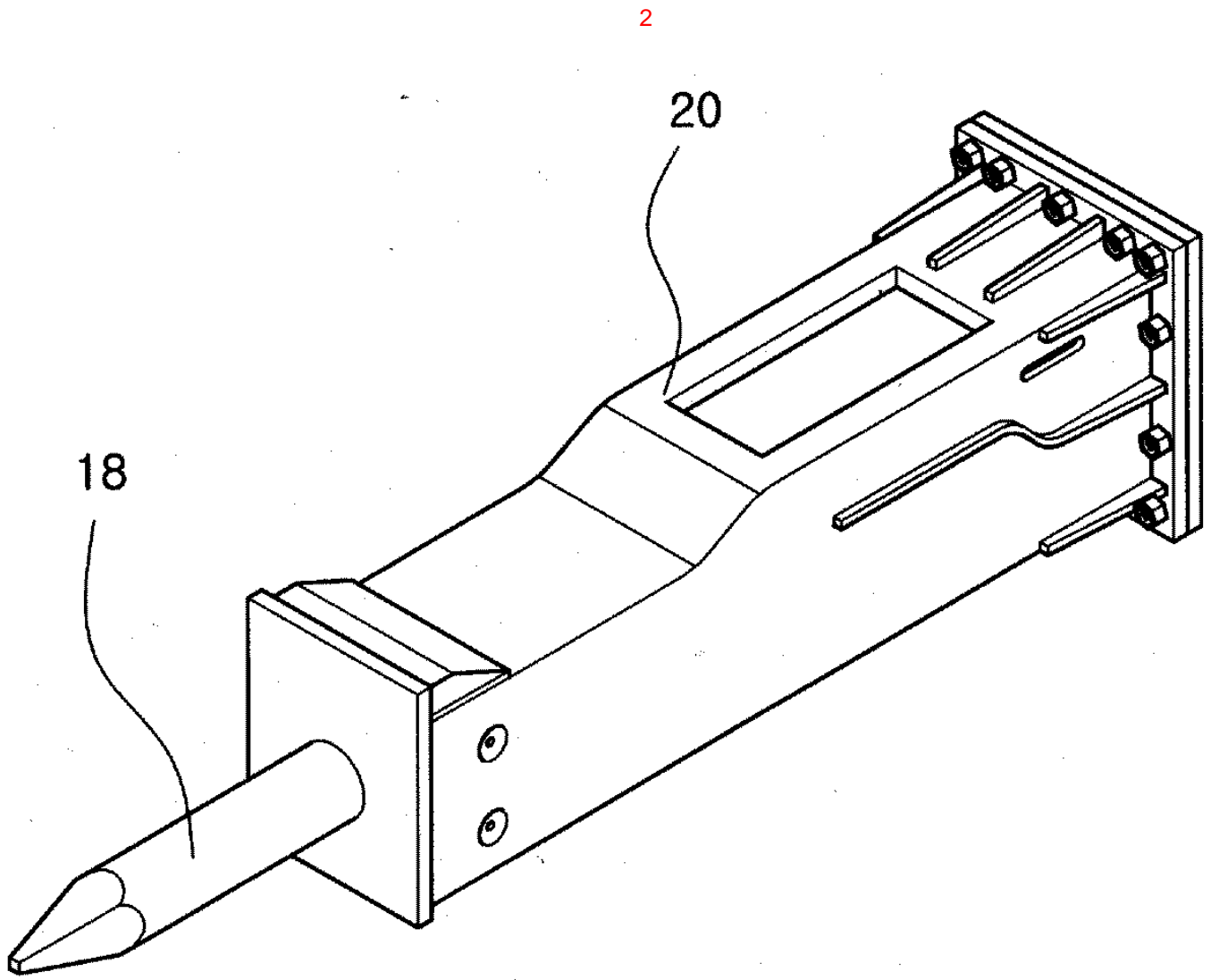

3

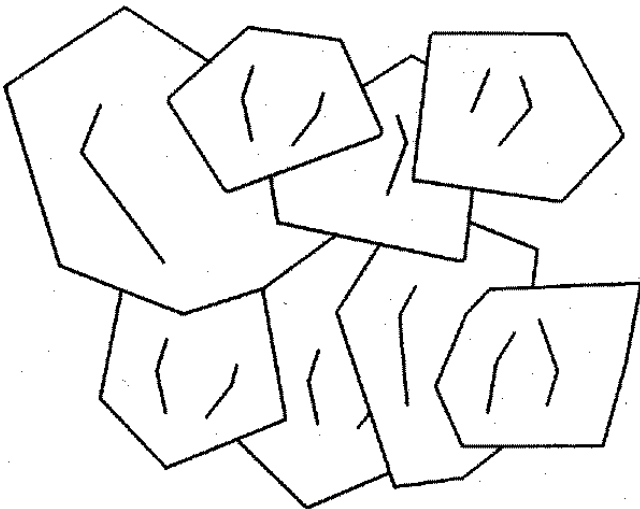
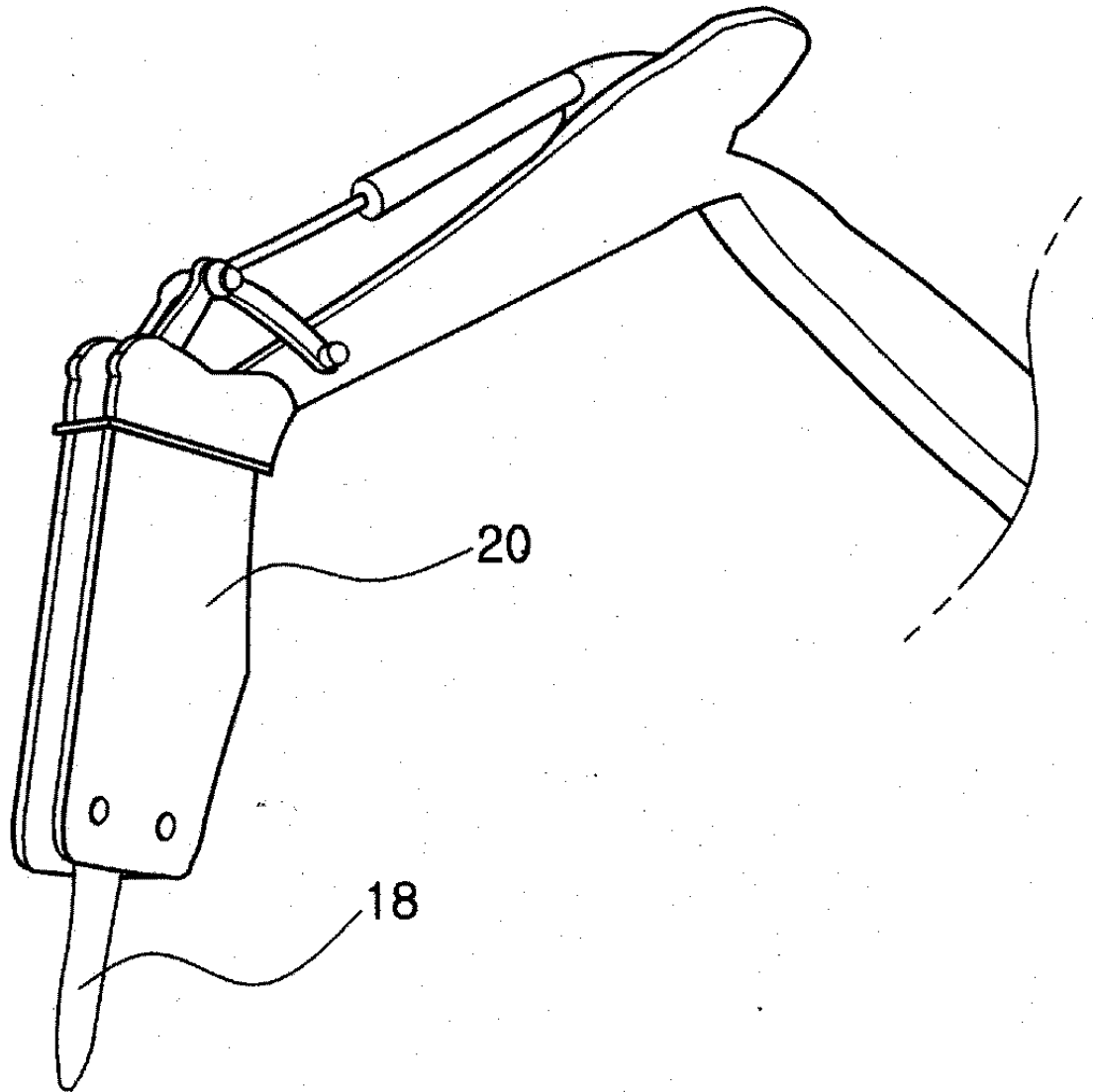

4a

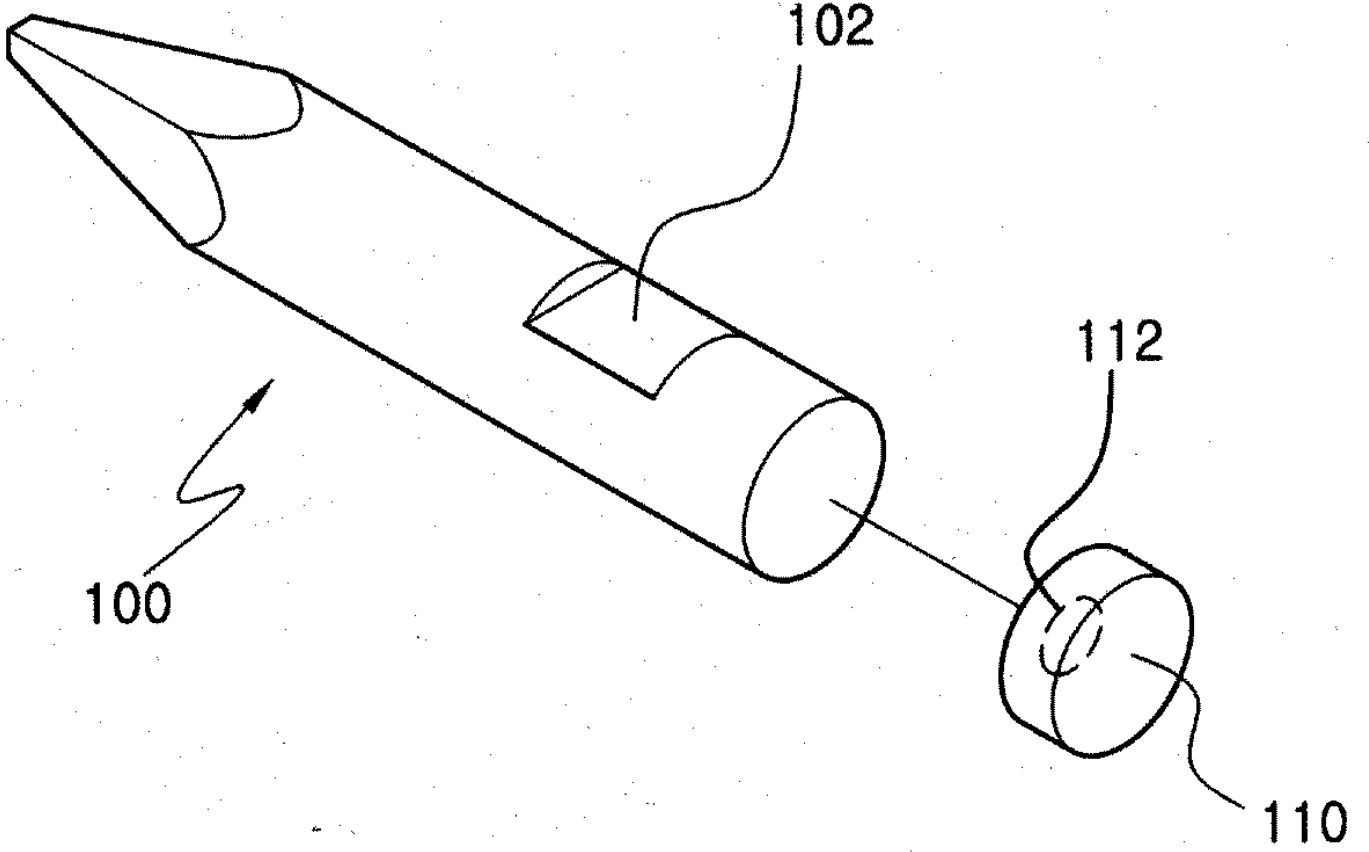

4b

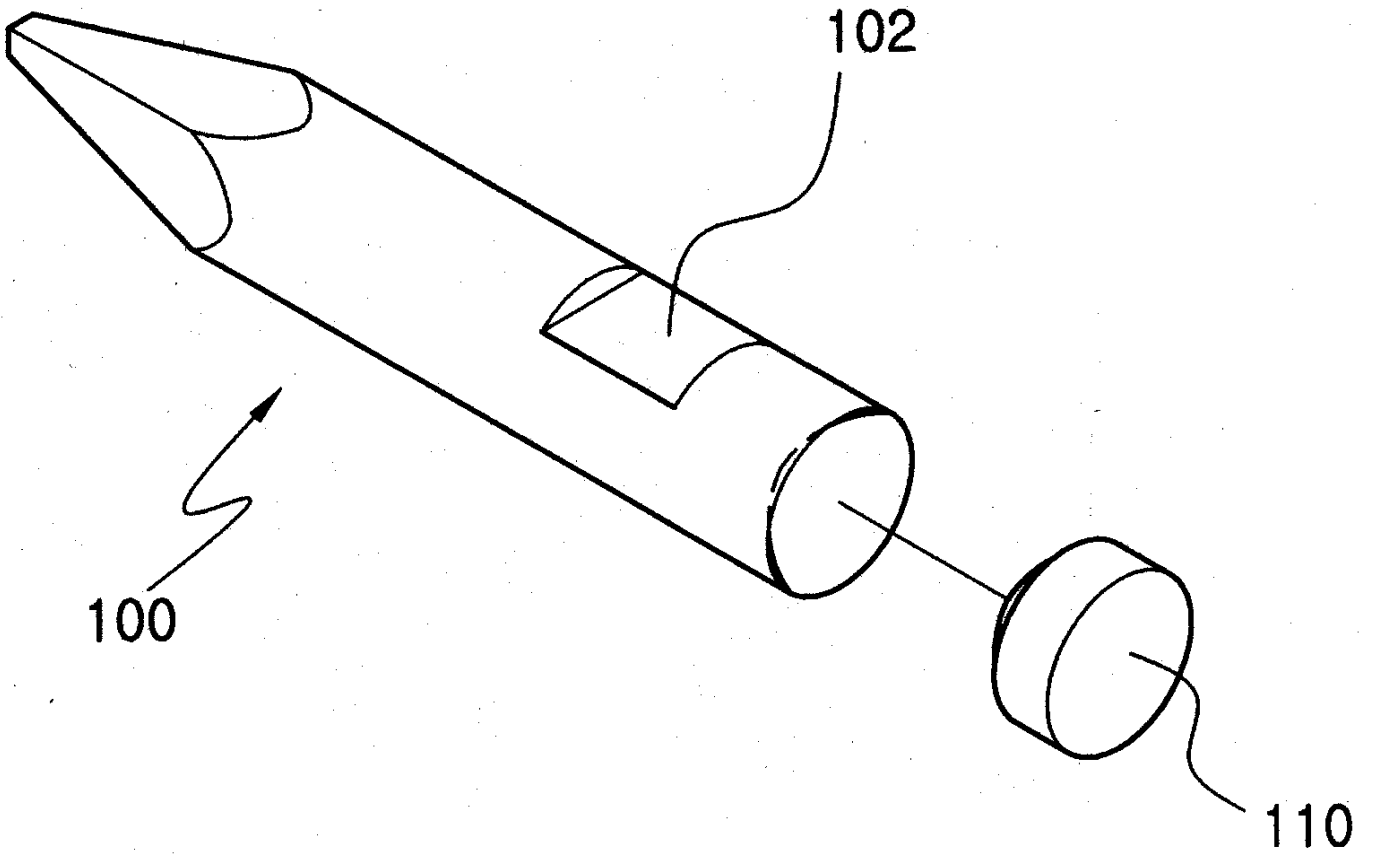

4c

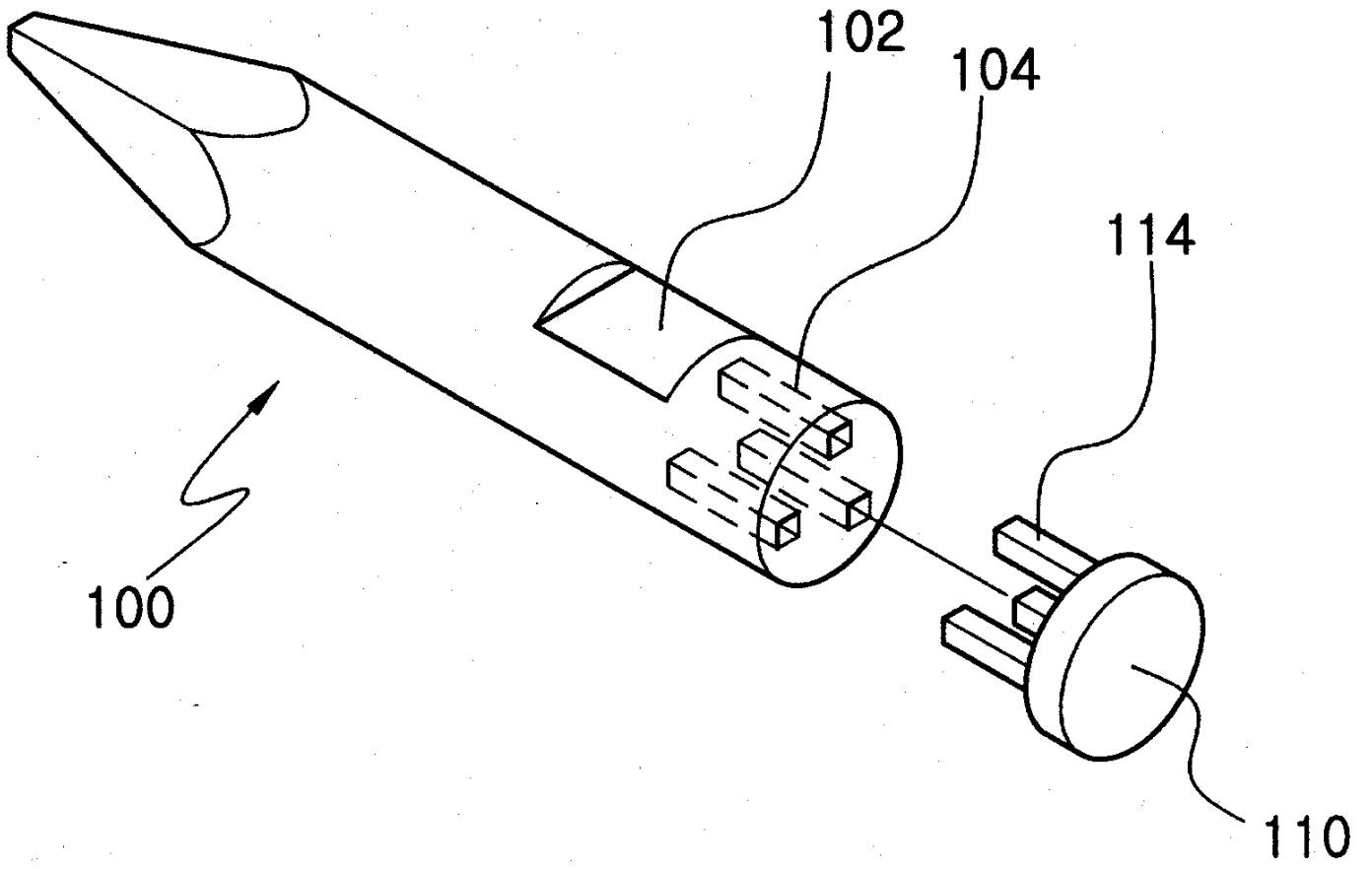

4d

