

(19) **DANMARK**

(10) **DK/EP 2784235 T3**



Patent- og  
Varemærkestyrelsen

(12) **Oversættelse af  
europæisk patentskrift**

- 
- (51) Int.Cl.: **E 04 B 9/06 (2006.01)** **E 04 B 9/20 (2006.01)**
- (45) Oversættelsen bekendtgjort den: **2016-09-05**
- (80) Dato for Den Europæiske Patentmyndigheds bekendtgørelse om meddelelse af patentet: **2016-06-29**
- (86) Europæisk ansøgning nr.: **14161677.1**
- (86) Europæisk indleveringsdag: **2014-03-26**
- (87) Den europæiske ansøgnings publiceringsdag: **2014-10-01**
- (30) Prioritet: **2013-03-26 EP 13161068**
- (84) Designerede stater: **AL AT BE BG CH CY CZ DE DK EE ES FI FR GB GR HR HU IE IS IT LI LT LU LV MC MK MT NL NO PL PT RO RS SE SI SK SM TR**
- (73) Patenthaver: **Rockwool International, Hovedgaden 584, 2640 Hedehusene, Danmark**
- (72) Opfinder: **Borgers, Stéphane, Jordaenslei 15, 2640 Mortsel, Belgien**  
**RAES, Tom, Heldenhuldelaan 4, 2640 Mortsel, Belgien**
- (74) Fuldmægtig i Danmark: **Plougmann Vingtoft A/S, Rued Langgaards Vej 8, 2300 København S, Danmark**
- (54) Benævnelse: **Ophængt loftssystem, ophængt loft og anvendelse af det ophængte loftssystem til at lave det ophængte loft**
- (56) Fremdragne publikationer:  
**EP-A1- 0 512 614**  
**US-A- 5 845 454**



## **DESCRIPTION**

**[0001]** The current invention relates to a suspended ceiling according to the preamble of the first claim.

**[0002]** The present invention also relates to a method for making suspended ceiling according to the invention.

**[0003]** Such suspended ceiling systems are already known to the person skilled in the art. US2004/0111995 A1 and EP512614A1 for example describe a suspended ceiling system for making a suspended ceiling. The suspended ceiling system comprises a wire hanger for suspending the suspended ceiling and a runner with a suspension opening. The wire hanger comprises suspension hooks at its end parts for hooking into the suspension opening of the runner of the suspended ceiling at one side and for further attachment to the construction at the other side. To hook the end parts of the wire hangers through the suspension openings in the runners, a rotating movement having its axis of rotation along length direction of the runner is required. In US2004/0111995 A1, one of the suspension hooks comprises a butted end part for attaching the suspension hook to the construction supporting the suspended ceiling.

**[0004]** However, it has been found that hooking the end part through the suspension opening with a rotating movement having its axis of rotation along length direction of the runner, is relatively difficult movement to perform by the installer as it requires the wire hanger to be moved considerably with respect to the runner due to the relatively large longitudinal dimensions of the wire hanger.

**[0005]** US5845454A describes a suspended ceiling according to the preamble of claim 1 in which a butted end part is received by the suspension opening by for example pushing the butted end part through the suspension opening along a pushing direction which is perpendicular to the suspension opening. However, it has been found that in the embodiment where the butted end part is pushed through the suspension opening along a pushing direction which is perpendicular to the suspension opening, the hook can unwantedly leave the suspension opening in a relative easy way, for example by pulling the hook out of the suspension opening along the pushing direction, for example during mounting of other runners to the suspended ceiling, while working on the suspended ceiling, during an earthquake, etc.

**[0006]** Therefore, it is desired to provide a suspended ceiling system in which the risk is reduced that the wire hanger unwantedly leaves the suspension opening without unduly increasing the difficulty with which the wire hangers are mounted to the runners of the suspended ceiling system.

**[0007]** This is achieved according to a suspended ceiling system according to the characterizing part of the first claim.

**[0008]** It has been found that with such wire hanger, the risk that the wire hanger unwantedly leaves the suspension opening is reduced without having to increase the protrusion of the wire hanger through the suspension opening. This way a reliable suspension of the runner can be achieved without increasing the risk that the ceiling tiles are hindered by the wire hanger.

**[0009]** According to the current invention, the wire hanger comprises a standing part adjacent to the end part of the wire hanger. The standing part is provided such that when the runner is hooked to the wire hanger at the suspension opening, the runner is located in between the butted end part and the standing part. An extending part of the suspension hook in between the butted end part and the standing part in such configuration protrudes through the suspension opening.

**[0010]** According to the current invention, the butted end part and the suspension opening are provided such that the suspension opening is provided to receive the butted end part of the suspension hook in a rotational movement with an axis of rotation along the standing part. Such a rotational movement of the suspension hook has been found to be easy to perform and requires less complicated movements for the installer installing the suspended ceiling when compared to a rotational movement with an axis of rotation which is, for example, perpendicular to the standing part and for example is positioned along the runner.

**[0011]** The largest cross section of the butted end part extending along a plane substantially parallel, or even parallel, to the suspension opening overlaps with at least part of the runner surrounding the suspension opening when the standing part is positioned substantially along, or even along, the gravitational direction and the runner is substantially horizontal, or even horizontal, for every position of the extending part protruding substantially perpendicularly, or even perpendicularly, through the suspension opening. In such configurations, it is avoided by the shape of the butted end part, more in particular by the overlapping part of the butted end part overlapping with the at least part of the runner surrounding the suspension opening, and the suspension opening that the butted end part leaves the suspension opening unwantedly in a movement along a direction substantially perpendicular to the suspension opening.

**[0012]** According to preferred embodiments of the current invention, the butted end part of the suspension hook of the wire hanger has a diameter which is larger than the diameter of the remainder of the wire hanger. More preferably, the butted end part of the wire hanger outwardly extends from the remainder of the wire hanger, preferably towards a direction opposing the gravitational direction. In this way, after moving the butted end part through the suspension opening, gravitation pulls down on the runner such that the suspension opening moves with respect to the butted end part such that part of the butted end part now faces the part of the runner surrounding the suspension opening preventing wire hanger from leaving the suspension opening. Preferably, the increase in diameter with respect to the remainder of the wire hanger is substantially abrupt such as to further prevent the butted end part from unwontedly moving back through the suspension opening.

**[0013]** According to preferred embodiments of the current invention, the rotational movement can be facilitated when the cross section of the butted end part along a plane comprising the standing and the extending part, which preferably is the largest cross section, fits in the suspension opening.

**[0014]** According to more preferred embodiments, the cross section of the butted end part along the plane comprising the standing and the extending part fits in the suspension opening when the standing part is positioned substantially along the gravitational direction and the runner is substantially horizontal. In such case, the movements required by the installer installing the suspended ceiling can be further facilitated as even less movements are required. According to this preferred embodiment, the wire hangers can be suspended to the structure in which the suspended ceiling is desired to be hung after which the runners are mounted to the wire hangers without having to perform elaborate movements with the wire hangers, limiting the time needed to mount the runners and thus the suspended ceiling and further for example limiting the risk that the wire hangers leave their suspended configuration due to the further manipulations of the installer.

**[0015]** According to more preferred embodiments, the butted end part comprises part of the outer surface of a sphere, preferably a spherical cap, the centre of the sphere being positioned substantially at the intersection of the standing part and the extending part. Such a configuration of the butted end part for example allows that by rotation of the butted end part with an axis of rotation along the standing part, the butted end part will be able to rotate through the suspension opening. Moreover, although alternative shapes for the butted end part are possible, the shape has been found relatively easy to make.

**[0016]** According to alternative embodiments of the current invention, the butted end part is in the form of a truncated cone. It has been found that with such a truncated cone a good interconnection between the suspension opening and the wire hanger can be achieved. Such truncated cone has for example been found to be easily pushable into the suspension opening whereas sufficiently preventing the butted end part from unwontedly leaving the opening especially when using a snap-fit connection. Moreover, the truncated shape allows that the protrusion of the wire hanger through the suspension opening is reduced, further decreasing the risk that ceiling tiles supported by the runner are hindered.

**[0017]** According to further alternative embodiments of the current invention, the suspension opening comprises a first suspension opening part with first dimensions allowing transfer of the butted end part through the suspension opening and a second suspension opening part with second more limited dimensions for preventing removal of the butted end part from the suspension opening. In such configuration transfer of the butted end part through the suspension opening, more in particular the first suspension opening part, is done along a first direction, for example by pushing the butted end part through the first suspension opening part, by tilting the butted end part through the first suspension opening part, etc. Moving the butted end part of the suspension hook through the first suspension opening part can be done, although not crucial for the invention, in a snap-fit way such as to further reduce the risk that the butted end part of the suspension hook unwontedly leaves the suspension opening. The butted end part is subsequently moved towards the second suspension opening part along a second direction such that the suspension hook protrudes through the second suspension opening part, the limited dimensions of the second suspension opening part preventing the unwanted removal of the butted end part from the suspension opening. The first direction and the second direction are different from each other such as to further reduce the risk that the butted end part unwontedly leaves the suspension opening of the runner. In such configuration, the dimensions of the opening between the first and the second suspension opening part is provided to allow at least part of the wire hanger to pass, although not critical for the invention the passing of the part of the wire hanger through the opening between the first and the second suspension opening part can be in a snap-fit connection.

**[0018]** According to further alternative embodiments of the current invention, the first suspension opening part is positioned below the second suspension opening part along gravitation direction. In such configuration of the first and the second suspension opening part, after having pushed the butted end part through the first suspension opening part, the butted end part is forced to the second suspension opening part by means of gravity, further reducing the risk that the butted end part unwontedly moves back to the first suspension opening part and there unwontedly leaves the first suspension opening part.

**[0019]** As referred to above, the first suspension opening part may be provided to receive the butted end part in a snap-fit connection such as to further reduce the risk that the butted end part of the suspension hook unwantedly leaves the suspension opening.

**[0020]** According to further alternative embodiments of the current invention, the first suspension opening part comprises at least one slit outwardly radiating from the edge of the first suspension opening part, the slit providing resilient properties to the edge of the first opening for providing the snap-fit connection. The slits can be provided in any way deemed appropriate by the person skilled in the art.

**[0021]** According to further alternative embodiments of the current invention, the first and/or the second suspension opening part are substantially circular and adjacent to each other. Although such configuration is preferred and allows an easy creation, for example, by punching through part of the runner at the desired location of the suspension opening, such configuration is not critical for the invention and can be determined by the person skilled in the art.

**[0022]** According to further alternative embodiments of the current invention, the first and the second suspension opening are substantially circular and the diameter of the second opening is smaller than the diameter of the first opening and more preferably substantially equals, or equals, the diameter of the wire hanger.

**[0023]** According to preferred embodiments of the current invention, the suspension opening is a triangle, especially when the butted end part and the suspension opening are provided such that the suspension opening is provided to receive the butted end part of the suspension hook in a rotational movement with an axis of rotation extending along the standing part. Without wanting to be bound by any theory such suspension opening allows a relative easy throughput of the butted end part through the suspension opening while at the same time decreasing the risk that the butted end part unwantedly leaves the suspension opening as the part of the butted end part facing the part of the runner surrounding the suspension opening and preventing wire hanger from leaving the suspension opening is enlarged, especially if the upper angle of the triangle is acute, for example when the triangle itself is an acute triangle. An example of an acute triangle for example is an equilateral, or a substantially equilateral, triangle.

**[0024]** According to preferred embodiments of the current invention, one of the heights of the acute triangle is positioned substantially along gravitational direction such that one of the angles of the triangle is positioned in an upper position improving guidance of the extending part of the wire hanger towards that angle.

**[0025]** The invention relates to a suspended ceiling. In such a ceiling, the suspension opening of the runner receives the butted end part of the hook with the suspension hook partly protruding through the suspension opening with the butted end part and the opposing end part of the suspension hook located at opposing sides of the suspension opening.

**[0026]** According to preferred embodiments of the current invention, the butted part hooks behind an edge of the suspension opening such as to prevent the butted end part of the hook from leaving the opening.

**[0027]** According to the current invention, the runner is a T-runner comprising a bead along the upper edge of its upright web. Although not critical for the invention, such runners are widely known and readily available to the person skilled in the art. However, other systems, such as for example so-called bandraaster systems, are also possible.

**[0028]** According to the current invention, the extending part of the suspension hook in between the butted end part and the standing part protruding through the suspension opening has a length which is at least half of the width of the bead of the runner. The length of the standing part protruding through the suspension opening and the dimensions of the butted end part are adapted such that the butted end part does not substantially extend beyond the bead when mounted to the runner such that the risk that the wire hanger interferes with ceiling tiles positioned on the runner is reduced.

**[0029]** The invention will be further elucidated by means of the following description and the appended figures.

Figure 1 shows a suspended ceiling according to the present invention.

Figures 2 - 7 show different steps of a method for making the suspended ceiling according to the present invention.

**[0030]** In the following detailed description, numerous specific details are set forth in order to provide a thorough understanding of the invention and how it may be practiced in particular embodiments. However, it will be understood that the present invention may be practiced without these specific details. In other instances, well-known methods, procedures and techniques have not been described in detail, so as not to obscure the present invention.

**[0031]** The present invention will be described with respect to particular embodiments and with reference to certain drawings but the invention is not limited thereto but only by the claims. The drawings described are only schematic and are non-limiting. In the drawings, the size of some of the elements may be exaggerated and not drawn on scale for illustrative purposes. The dimensions and the relative dimensions do not necessarily correspond to actual reductions to practice of the invention.

**[0032]** Furthermore, the terms first, second, third and the like in the description and in the claims, are used for distinguishing between similar elements and not necessarily for describing a sequential or chronological order. The terms are interchangeable under appropriate circumstances and the embodiments of the invention can operate in other sequences than described or illustrated herein.

**[0033]** Moreover, the terms top, bottom, over, under and the like in the description and the claims are used for descriptive purposes and not necessarily for describing relative positions. It is to be understood that the terms so used are interchangeable under appropriate circumstances and that the embodiments of the invention described herein are capable of operation in other orientations than described or illustrated herein.

**[0034]** The term "comprising", used in the claims, should not be interpreted as being restricted to the means listed thereafter; it does not exclude other elements or steps. It needs to be interpreted as specifying the presence of the stated features, integers, steps or components as referred to, but does not preclude the presence or addition of one or more other features, integers, steps or components, or groups thereof. Thus, the scope of the expression "a device comprising means A and B" should not be limited to devices consisting only of components A and B.

1. 1. Suspended ceiling system
2. 2. suspended ceiling
3. 3. wire hanger
4. 4. suspension hook
5. 5. suspension opening
6. 6. runner
7. 7. butted end part
8. 8. end part
9. 9. standing part
10. 10. extending part
11. 11. rotational movement
12. 12. axis of rotation of the rotational movement
13. 13. the intersection of the standing part and the extending part
14. 14. bead
15. 15. upright web of the runner
16. 16. supporting web of the runner
17. 17. wire hanger clamp
18. 18. further wire hanger
19. 19. further suspension hook

**[0035]** Figure 1 shows a suspended ceiling according to the present invention.

**[0036]** The suspended ceiling 2 shown in figure 1 is made from a suspended ceiling system 1 according to the invention.

**[0037]** The suspended ceiling system 1 for making the suspended ceiling 2 comprises a wire hanger 3 for suspending the suspended ceiling 2, more in particular a runner 6 of the suspended ceiling 2.

**[0038]** The wire hanger 3 comprises a suspension hook 4 at an end part 8 of the wire hanger 3 for hooking into a suspension opening 5 of the runner 6 of the suspended ceiling 2. The suspension hook 4 comprises a butted end part 7. As shown in figure 1, the wire hanger 3 preferably further comprises a standing part 9 adjacent to the end part 8 of the wire hanger 3. The standing

part 9 is such that the runner 6, when hooked to the wire hanger 3, at the suspension opening 5 is located in between the butted end part 7 and the standing part 9. As the wire hanger 3 often is suspended to a structure, the standing part 9 often is a vertical part of the wire hanger 3. The wire hanger 3 further preferably comprises an extending part 10 of the suspension hook 4 in between the butted end part 7 and the standing part 9 protruding through the suspension opening 5, as also shown in figure 1. The wire hanger 3, and more precisely the standing part 9, the suspension hook 4 with the butted end part 7 and the extending part 10 at the end part 8, is made from a wire, preferably a bent wire. The wire preferably is a metal wire, for example a steel wire or even a stainless steel wire or a galvanized steel, for example having a thickness of about 4 mm depending on the desired use of the wire. The butted end part 7 preferably is made by butting, a process which is known for making, for example, metal bucket carrying handles often called bails often for plastic buckets.

**[0039]** The wire hanger 3 shown in figure 1 further is attached to a further wire hanger 18 having a further suspension hook 19 using a wire hanger clamp 17. Such a wire hanger clamp 17 and further wire hanger 18 allow the adjustment of the height from which the suspended ceiling suspends from the ceiling of the structure to which it is suspended. Such configuration is however not critical to the current invention, as the wire hanger 3 can be provided with a further suspension hook 19 at a further end part 20 opposing the end part 8. The clamp 17 for example is made from steel, for example galvanized steel, spring steel, preferably galvanized spring steel.

**[0040]** The butted end part 7 and the suspension opening 5 are adapted to each other such that the suspension opening 5 is provided to receive the butted end part 7 of the suspension hook 4. This is for example shown in figure 4 in which the cross-section of the butted end part 7 and the suspension opening 5 are compared such that it can be observed that the butted end part 7 fits inside the suspension opening 5. Thereto, the cross section of the butted end part 7 extending along a plane comprising the standing 9 and the extending part 10 fits in the suspension opening 5. More in particular, figure 4 shows that the cross section of the butted end part 7 extending along a plane comprising the standing and the extending part 10 fits in the suspension opening 5 when the standing part 9 is positioned substantially along the gravitational direction and the runner 6 is substantially horizontal.

**[0041]** Figure 4 further shows that the butted end part 7 comprises part of the outer surface of a sphere, in particular as shown in figure 4 a spherical cap. The centre of the sphere preferably is positioned substantially, or positioned, at the intersection 13 of the standing part 9 and the extending part 10.

**[0042]** Although it has been found that such a butted end part 7 has benefits with respect to providing the butted end part 7 through the suspension opening 5, as will be explained further down, and the way of manufacturing the butted end part 7 having such a shape can be performed relatively easy, such shape is not critical for the invention and can be further adapted depending on the desired application by the person skilled in the art. The butted end part 7 can for example have the shape of an ellipse, a cone, a truncated cone, a pyramid, etc.

**[0043]** The runner 6 of the suspended ceiling system 1 and eventually of the suspended ceiling 2, is a known T-shaped, for example metal, runner, as for example shown in the figures. Such a runner 6 has an upright web 15 with a bead 14 along its upper edge and a supporting web 16, provided to support ceiling tiles, not shown for clarity sake. The suspension opening 15 is provided in the upright web 15, as shown in the figures.

**[0044]** The ceiling tiles supported by the runner 6 can be any type of ceiling tile deemed appropriate by the person skilled in the art such as for example a mineral wool ceiling tile. However, other types of ceiling tile are possible such as for example metal ceiling tiles, wood ceiling tiles, etc.

**[0045]** As can be seen in, for example, figure 4, the suspension opening 5 is a triangle, more specifically an acute triangle. More specifically, one of the heights of the acute triangle is positioned substantially along gravitational direction. This is however not critical for the invention and other shapes can be devised by the person skilled in the art keeping in mind that the butted end part 7 is to be received in the suspension opening 5.

**[0046]** In the suspended ceiling 2 as shown in figure 1, the suspension opening 5 of the runner 6 receives the butted end part 7 of the suspension hook 4 with the suspension hook 4 partly protruding through the suspension opening 5 with the butted end part 7 and the opposing end part 8 of the suspension hook 4 located at opposing sides of the suspension opening 5. This is for example shown in more detail in figure 7.

**[0047]** As can be further seen in figure 7, the butted part preferably hooks behind an edge of the suspension opening 5 such as to prevent the butted end part 7 of the hook from leaving the opening.

[0048] In such configuration, as shown in figure 7, the runner 6 at the suspension opening 5 is located in between the butted end part 7 and the standing part 9, the extending part 10 of the suspension hook 4 in between the butted end part 7 and the standing part 9 protruding through the suspension opening 5. Thereto, the extending part 10 has a length of at least half of the width of the bead 14 of the runner 6.

[0049] Although different ways can be devised to provide the mounting of the butted end part 7 through the suspension opening 5 while, preferably, keeping the risk that the butted end part 7 unwantedly leaves the suspension opening 5, such as for example a snap fit connection or with suspension openings allowing so-called bayonet-type mounts, it has been found that preferably the butted end part 7 and the suspension opening 5 are provided such that the suspension opening 5 is provided to receive the butted end part 7 of the suspension hook 4 in a rotational movement 11 with an axis of rotation 12 extending along the standing part 9.

[0050] This type of mount is illustrated in figures 2 - 7.

[0051] Figure 2 shows a first step of mounting the wire hanger 3 to the runner 6 in which step the wire hanger 3 is brought closer to the runner 6 with the butted end part 7 oriented such that plane comprising the standing part 9 and the extending part 10 is substantially parallel to the upright web 15 of the runner 6.

[0052] Figure 3 shows a result of such positioning along a direction along the upright web 15 of the runner 6. Figure 4 shows an overview of the configuration of figure 3 along a direction perpendicular to the direction of the upright web 15 of the runner 6.

[0053] Figure 5 shows the rotational movement 11 of the butted end part 7 with an axis of rotation 12 extending along the standing part 9. As indicated in figure 4 when comparing the cross section of the butted end part 7 and the dimensions of the suspension opening 5, such rotational movement 11 is allowed and will move the butted end part 7 through the suspension opening 5.

[0054] Figure 6 shows the result of the rotational movement 11 in which the butted end part 7 has fully rotated through the suspension opening 5. It can be seen that although the butted end part 7 was allowed through the suspension opening 5 by the rotating movement 11, it is prevented from leaving the suspension opening along a linear movement, for example a retracting movement back through the suspension opening 5 due to the dimensions of the suspension opening 5. Indeed, it can be seen that the largest cross section of the butted end part 7 extending along a plane substantially parallel to the suspension opening 5 overlaps with at least part of the runner 6 surrounding the suspension opening 5 when the standing part 9 is positioned substantially along the gravitational direction and the runner 6 is substantially horizontal, for every position of the extending part 10 protruding substantially perpendicularly through the suspension opening 5.

[0055] Figure 7 shows that due to the shape of the suspension opening, which tapers along a direction opposing gravitational direction, the risk that the butted end part 7 unwantedly leaves the suspension opening 5 is further reduced.

## **REFERENCES CITED IN THE DESCRIPTION**

This list of references cited by the applicant is for the reader's convenience only. It does not form part of the European patent document. Even though great care has been taken in compiling the references, errors or omissions cannot be excluded and the EPO disclaims all liability in this regard.

### **Patent documents cited in the description**

- [US20040111995A1 \[0003\] \[0003\]](#)
- [EP512614A1 \[0003\]](#)
- [US5845454A \[0005\]](#)

**Patentkrav**

1. Ophængt loft (1) omfattende en trådhænger (3) til ophængning af det ophængte loft (2) og en løbeliste (6) med en ophængningsåbning (5),  
5 trådhænger (3) omfattende en ophængningskrog (4) ved en endedel (8) af trådhænger (3) til hægning ind i ophængningsåbningen (5) af løbelisten (6) af det ophængte loft (2), ophængningskrogen (4) omfattende en fortykket endedel (7), hvor ophængningsåbningen (5) modtagende den fortykkede endedel (7) af ophængningskrogen (4) med ophængningskrogen (4) delvist fremspringende  
10 igennem ophængningsåbningen (5) med den fortykkede endedel (7) og den modstående endedel (8) af ophængningskrogen (4) lokaliseret ved modstående sider af ophængningsåbningen (5),  
hvor trådhænger (3) omfatter en stående del (9) tilstødende endedelen (8) af trådhænger (3), hvor løbelisten (6) når hægtet til trådhænger (3) ved  
15 ophængningsåbningen (5) er lokaliseret imellem den fortykkede endedel (7) og den stående del (9), en udstrækkende del (10) af ophængningskrogen (4) imellem den fortykkede endedel (7) og den stående del (9) fremspringer igennem ophængningsåbningen (5), hvor den fortykkede endedel (7) og ophængningsåbningen (5) er tilvejebragt således at ophængningsåbningen (5) er  
20 tilvejebragt til at modtage den fortykkede endedel (7) af ophængningskrogen (4) i en rotationsbevægelse (11) med en rotationsakse (12) strækkende sig langs den stående del (9), hvor det største tværsnit af den fortykkede endedel (7) strækkende sig langs et plan i alt væsentligt parallelt med ophængningsåbningen (5) overlapper med mindst en del af løbelisten (6) omgivende  
25 ophængningsåbningen (5) når den stående del (9) er positioneret i alt væsentligt langs tyngderetningen og løbelisten (6) er i alt væsentligt horisontal, for hver position af den udstrækkende del (10) fremspringende i alt væsentligt vinkelret igennem ophængningsåbningen (5) **kendetegnet ved at** løbelisten (6) er en T-løbeliste (6) omfattende en vulst (14) langs den øvre kant af sin opretstående  
30 krop, og den udstrækkende del (10) har en længde på mindst halvdelen af bredden af vulsten (14) af løbelisten (6) og **ved at** længden af den udstrækkende del fremspringer igennem ophængningsåbningen og dimensionerne af den fortykkede endedel er indrettede således at den fortykkede endedel i alt væsentligt ikke strækker sig ud over vulsten når monteret til løbelisten.

2. Ophængt loft (1) ifølge krav 1, hvor tværsnittet af den fortykkede endedel (7) strækkende sig langs et plan omfattende den stående og den udstrækkende del (9, 10) passer i ophængningsåbningen (5).
- 5 3. Ophængt loft (1) ifølge krav 2, hvor tværsnittet af den fortykkede endedel (7) strækkende sig langs et plan omfattende den stående og den udstrækkende del (10) passer i ophængningsåbningen (5) når den stående del (9) er positioneret i alt væsentligt langs tyngderetningen og løbelisten (6) er i alt væsentligt horisontal.
- 10
4. Ophængt loft (1) ifølge krav 3, hvor den fortykkede endedel (7) omfatter en del af den ydre flade af en kugle, hvor midten af kuglen er positioneret i alt væsentligt ved skæringspunktet (13) af den stående del (9) og den udstrækkende del (10).
- 15
5. Ophængt loft (1) ifølge krav 4, hvor delen af kuglen er en kuglekappe.
6. Ophængt loft (1) ifølge et hvilket som helst af kravene 1 - 5, hvor ophængningsåbningen (5) er en trekant.
- 20
7. Ophængt loft (1) ifølge krav 6, hvor trekanten er spidsvinklet.
8. Ophængt loft (1) ifølge krav 7, hvor en af højderne af den spidsvinklede trekant er positioneret i alt væsentligt langs tyngderetningen.
- 25
9. Ophængt loft (2) ifølge et hvilket som helst af de foregående krav, hvor den fortykkede del hægter bag en kant af ophængningsåbningen (5) for at forhindre den fortykkede endedel (7) af krogen i at forlade åbningen.
- 30 10. Fremgangsmåde til fremstilling af et ophængt loft (2) ifølge et hvilket som helst af de foregående krav, **kendetegnet ved at** ophængningskrogen (4) hægtes ind i ophængningsåbningen (5) af løbelisten (6) ved at overføre en fortykket endedel (7) af ophængningskrogen (4) igennem ophængningsåbningen (5) i en rotationsbevægelse (11) med en rotationsakse (12) strækkende sig langs
- 35 den stående del (9).

DRAWINGS

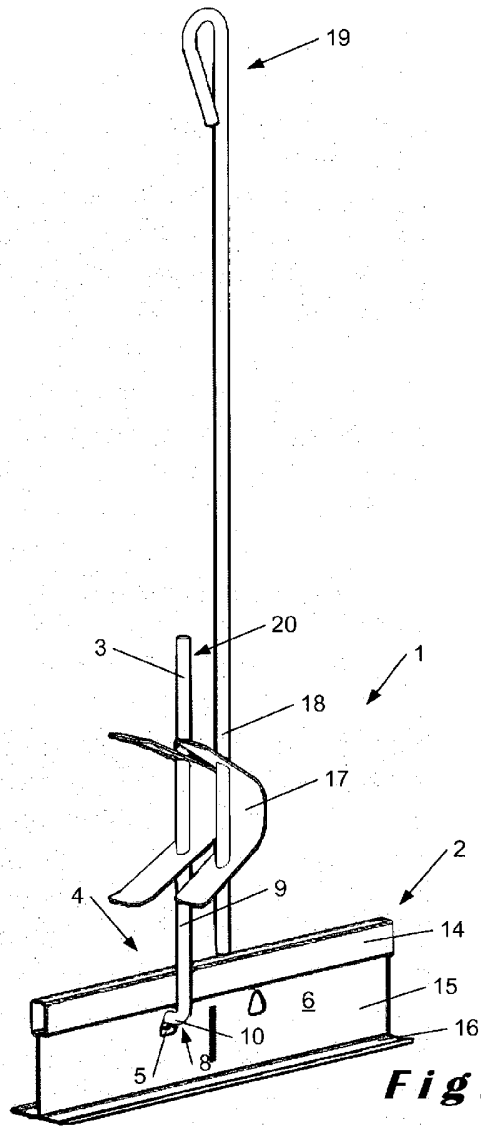

**Fig. 1**

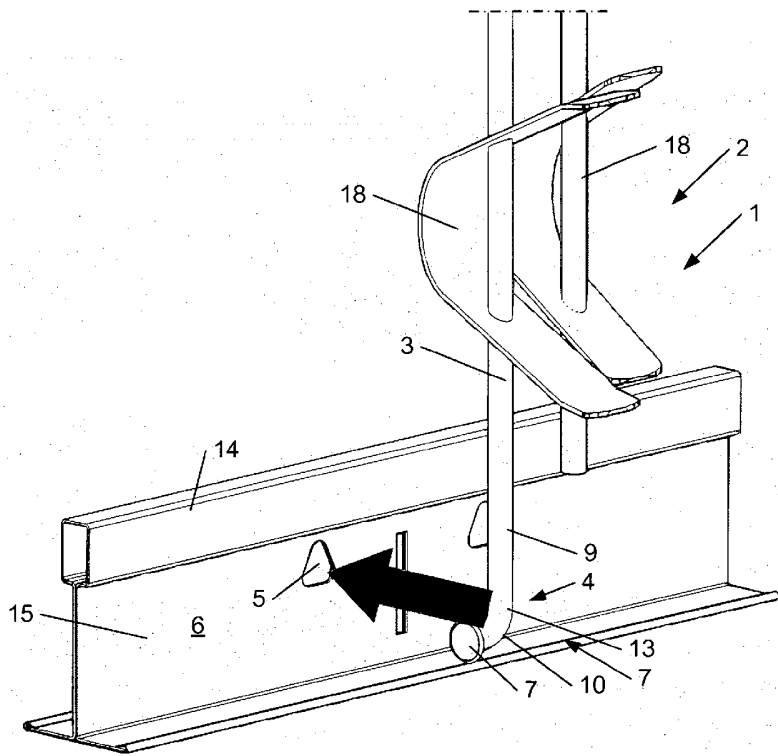

**Fig. 2**

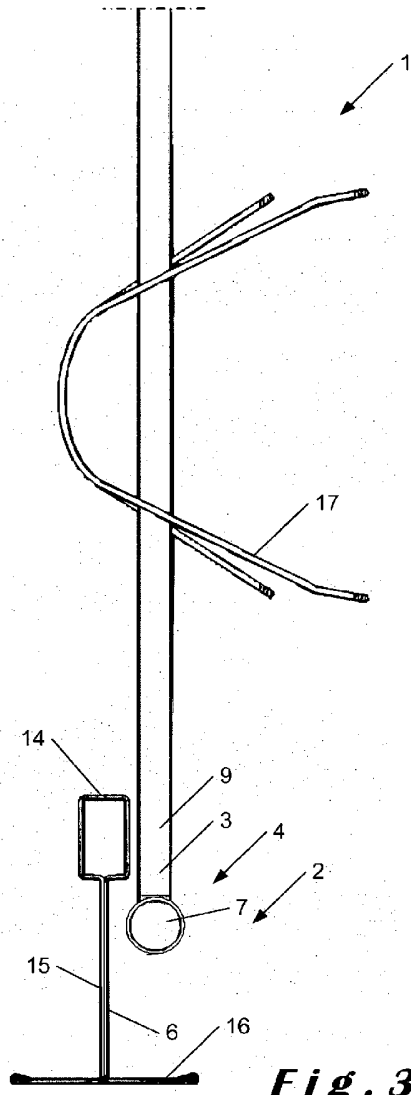

**Fig. 3**

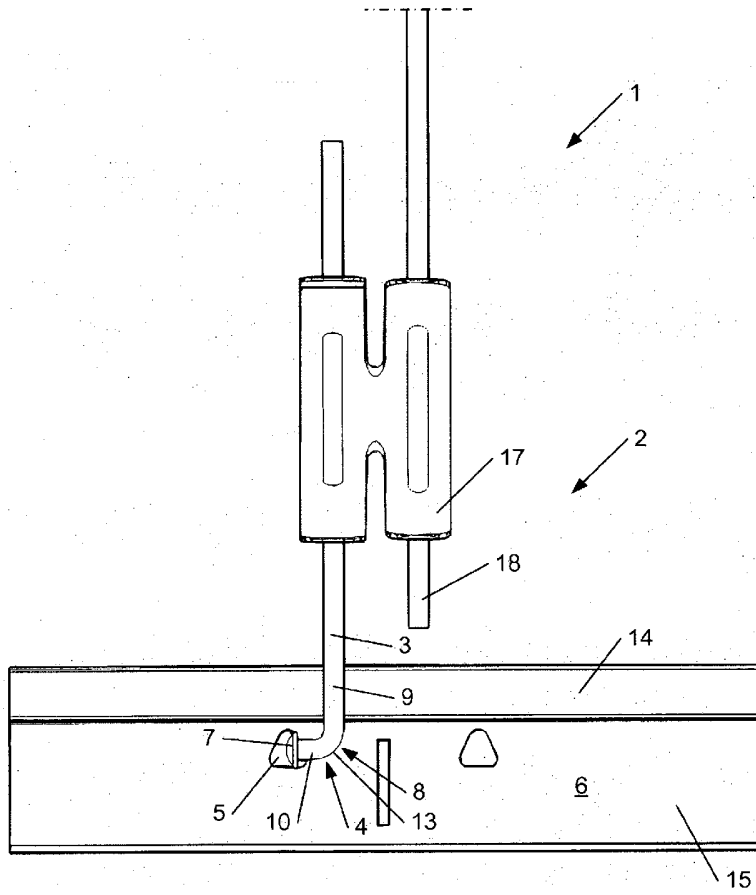

**Fig. 4**

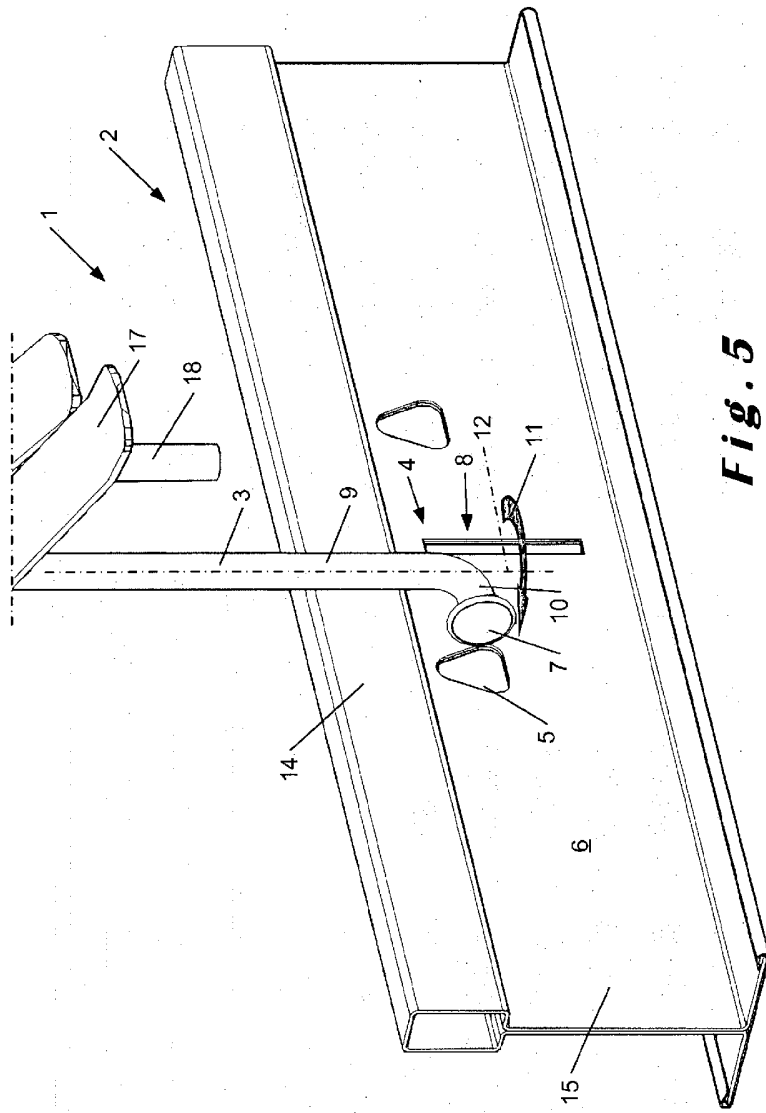

**Fig. 5**

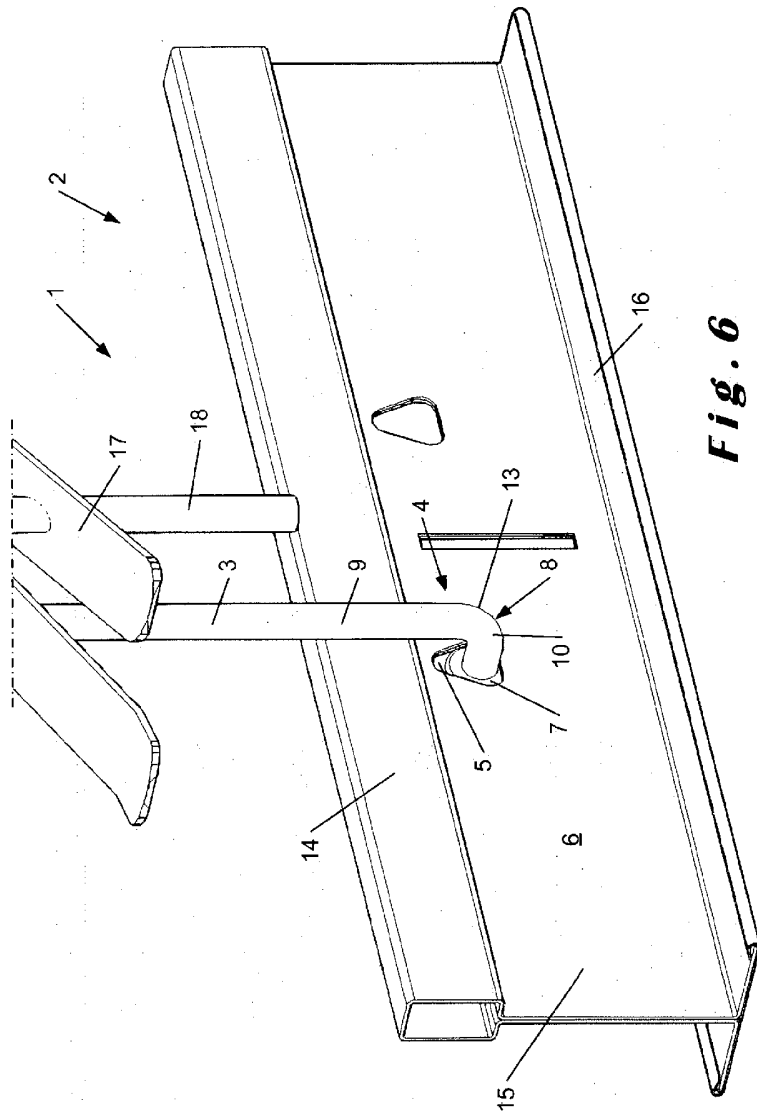

Fig. 6

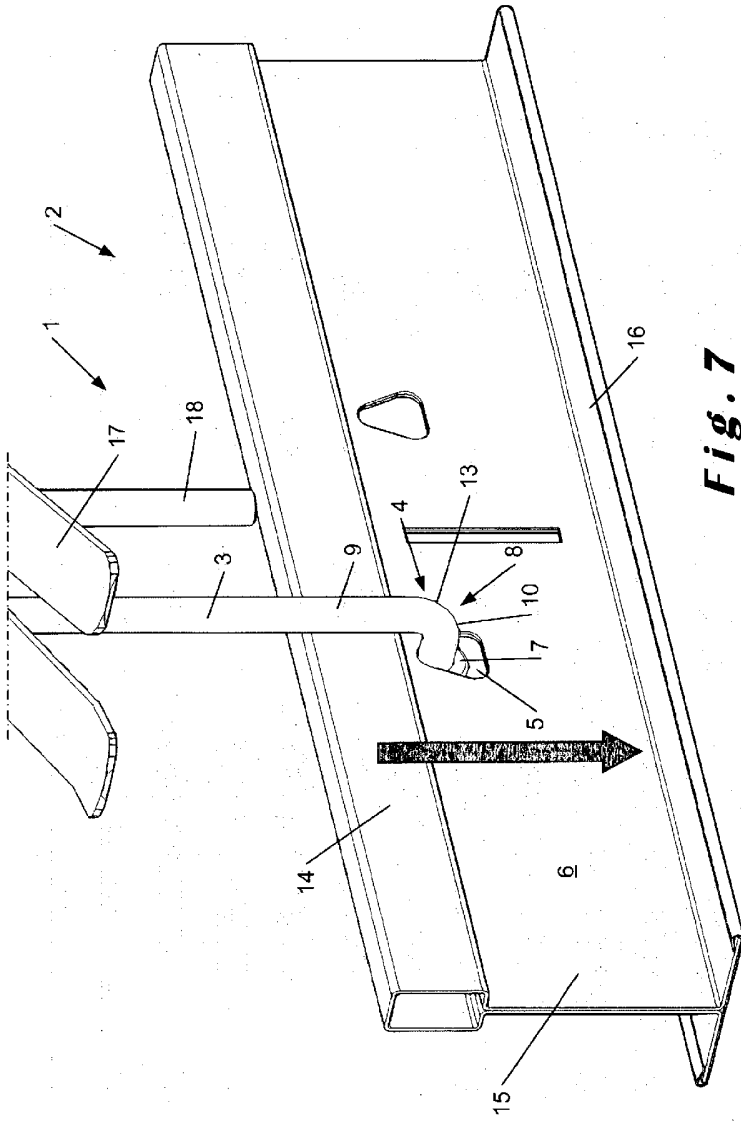

Fig. 7