



US00D677754S

(12) **United States Design Patent**  
**Pierog et al.**

(10) **Patent No.:** **US D677,754 S**  
(45) **Date of Patent:** **\*\* Mar. 12, 2013**

(54) **HOUSING FOR A DEVICE WITH DUAL SOLENOID VALVES**

(75) Inventors: **Dennis W. Pierog**, Hoffman Estates, IL (US); **James D. Kimble**, DeKalb, IL (US)

(73) Assignee: **Robertshaw Controls Company**, Carol Stream, IL (US)

(\*\*) Term: **14 Years**

(21) Appl. No.: **29/376,248**

(22) Filed: **Oct. 4, 2010**

(51) **LOC (9) Cl.** ..... **23-01**

(52) **U.S. Cl.** ..... **D23/233**

(58) **Field of Classification Search** ..... D23/233-237, D23/244-249, 255-269, 310; 137/505, 613, 137/614; 251/129.01

See application file for complete search history.

(56) **References Cited**

**U.S. PATENT DOCUMENTS**

D205,118 S *	6/1966	Rhodes	.....	D23/235
6,789,572 B2 *	9/2004	Pierog et al.	.....	137/613
2003/0020037 A1 *	1/2003	Pierog et al.	.....	251/129.01

\* cited by examiner

*Primary Examiner* — Garth Rademaker  
(74) *Attorney, Agent, or Firm* — Reinhart Boerner Van Deuren P.C.

(57) **CLAIM**

We claim the ornamental design for a housing for a device with dual solenoid valves, as shown and described.

**DESCRIPTION**

FIG. 1 is a perspective view of a housing for a device with dual solenoid valves;  
FIG. 2 is a front view thereof;  
FIG. 3 is a back view thereof;  
FIG. 4 is a side view thereof;  
FIG. 5 is an opposite side view thereof;  
FIG. 6 is a top view thereof;  
FIG. 7 is a bottom view thereof; and,  
FIG. 8 is a top view of the housing for a device with dual solenoid valves, with the unclaimed structure shown in broken lines of FIG. 6 in a different orientation to illustrate portions of the claimed design obscured in FIG. 6, the portions of the claimed design obscured in FIG. 8 and shown in the other figures remaining part of the claimed ornamental design.

The broken lines of FIGS. 1-8 depict environmental subject matter only and form no part of the claimed design.

**1 Claim, 5 Drawing Sheets**

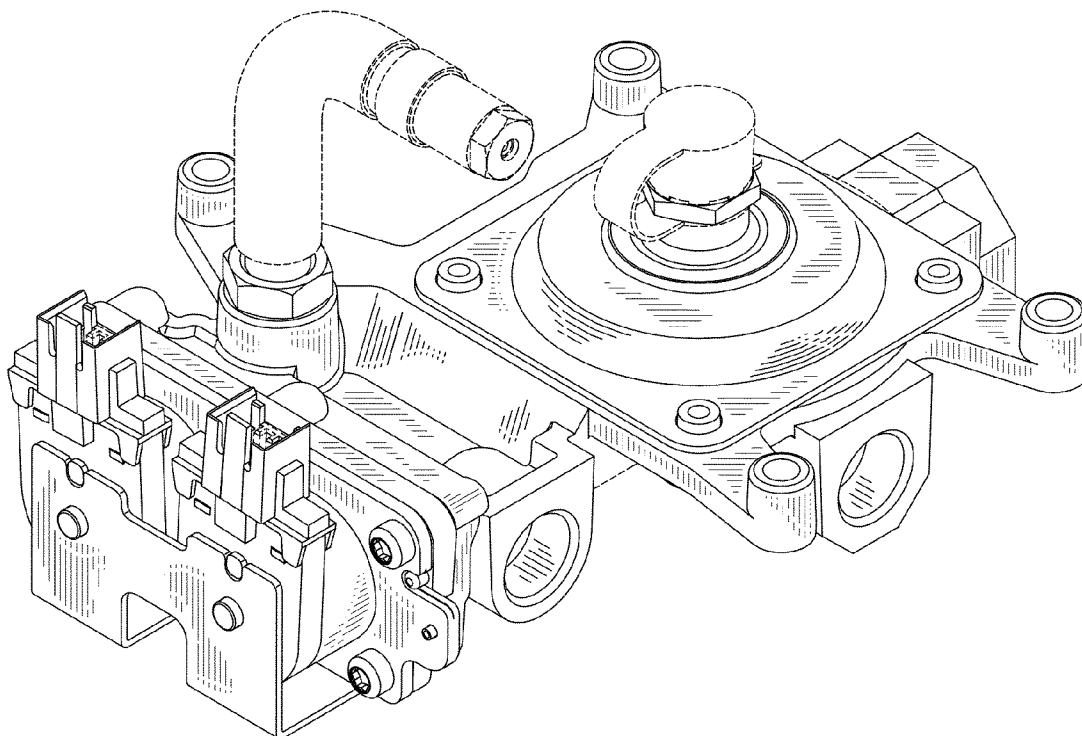

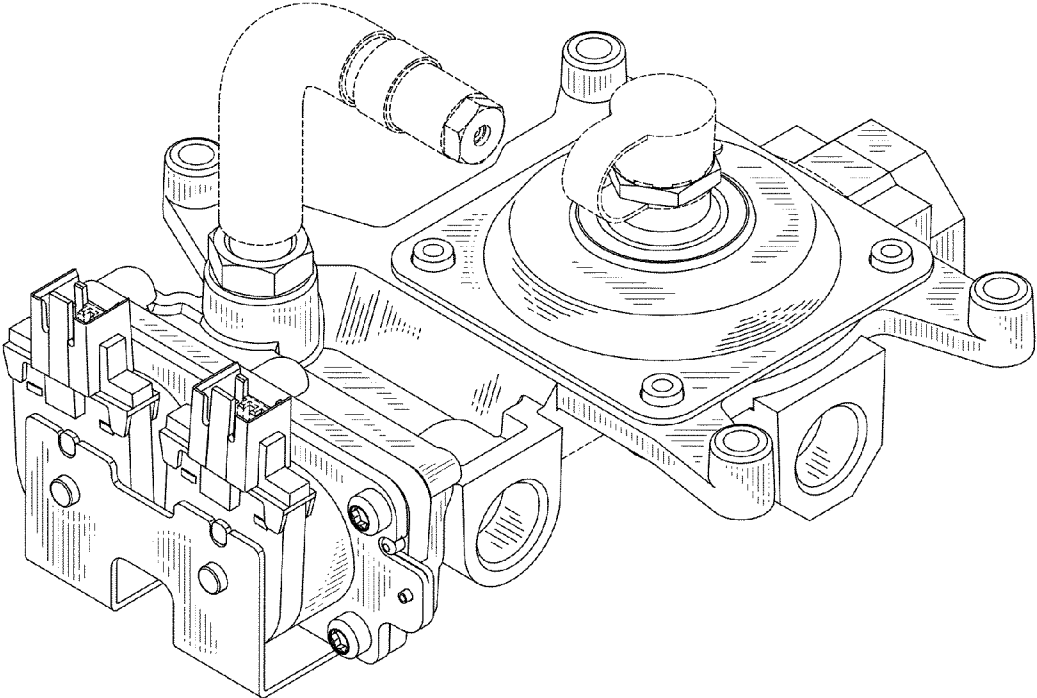

FIG. 1

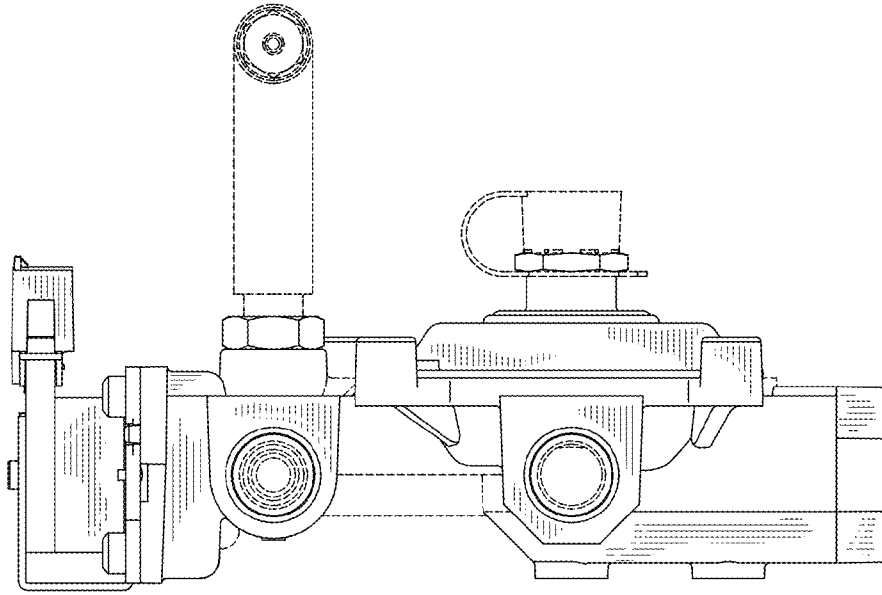

FIG. 2

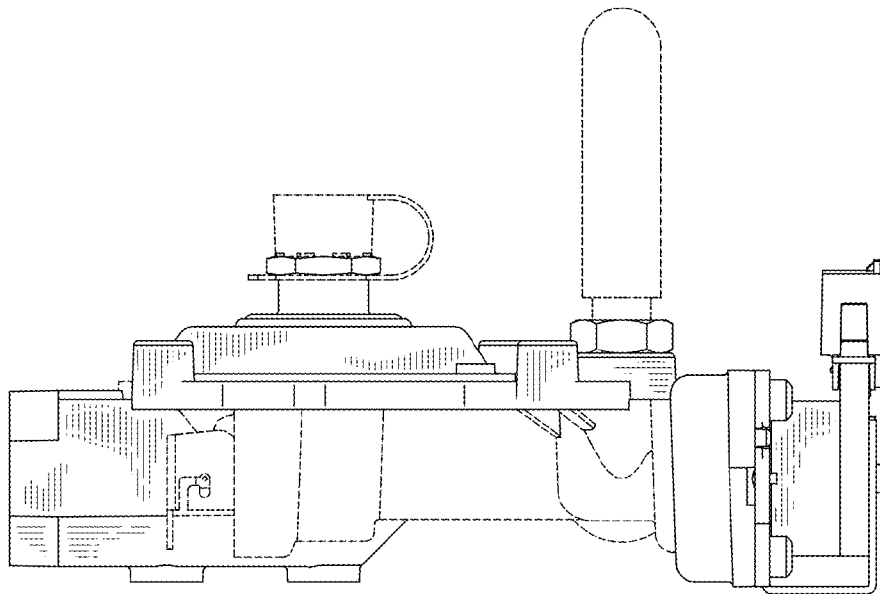

FIG. 3

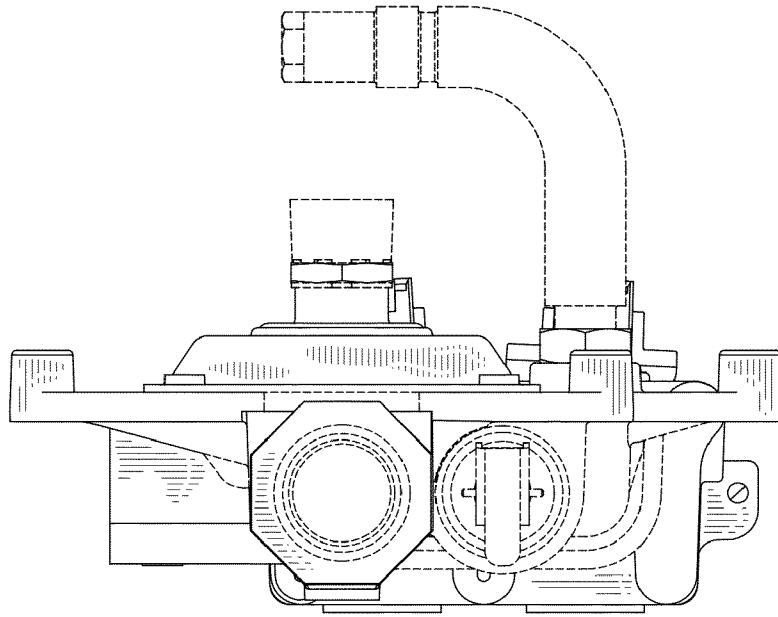

FIG. 4

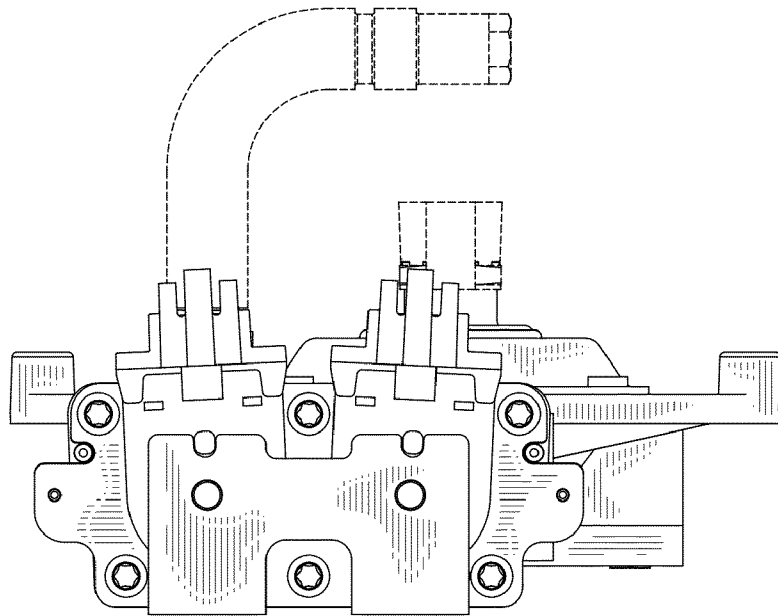

FIG. 5

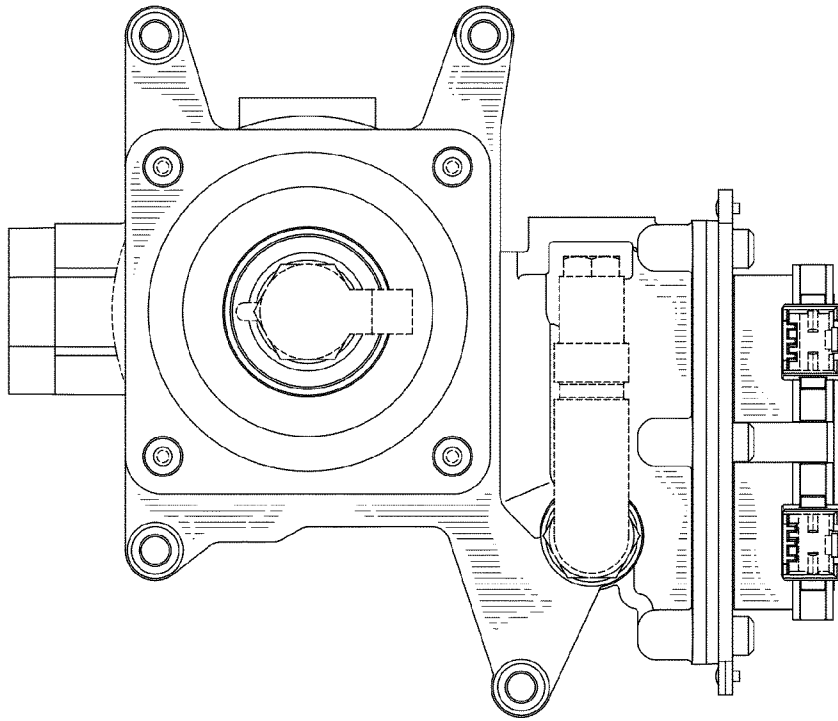

FIG. 6

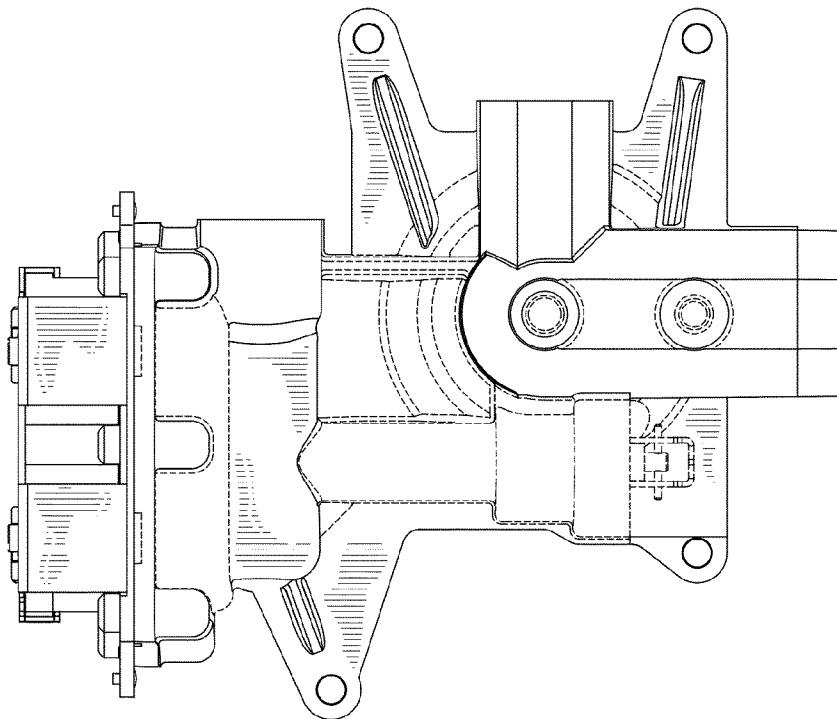

FIG. 7

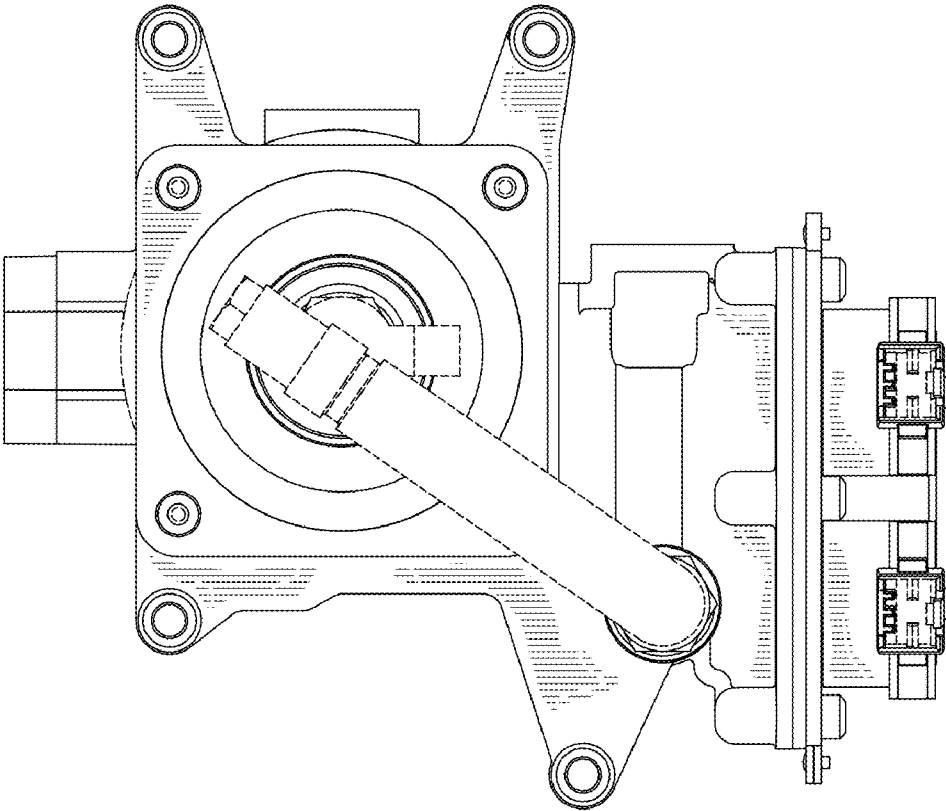

FIG. 8