

No. 837,815.

PATENTED DEC. 4, 1906.

H. S. ESCH.  
SPRING MOTOR.

APPLICATION FILED JAN. 4, 1905.

2 SHEETS—SHEET 1.

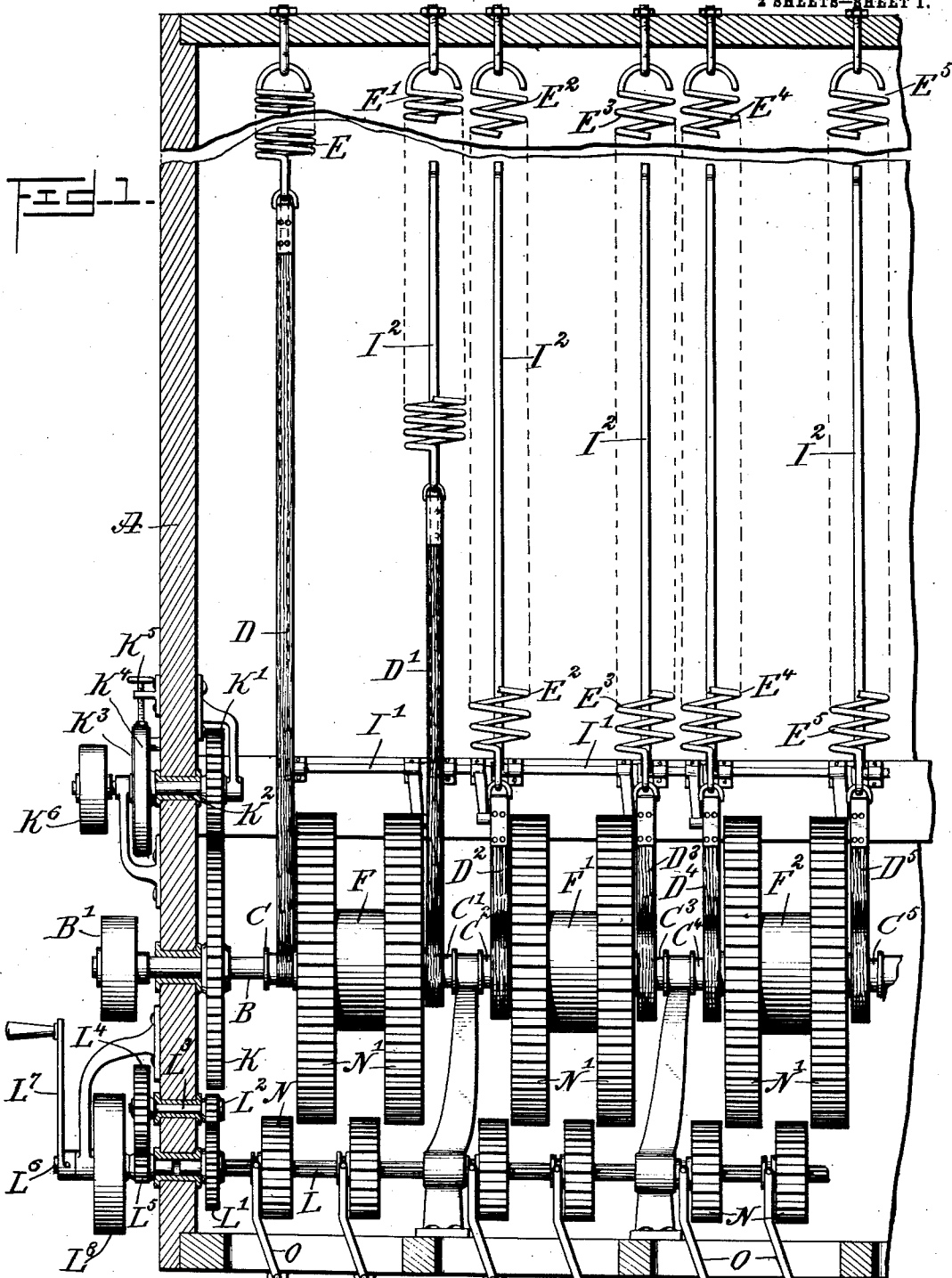

WITNESSES:  
*L. Empford Handy*  
*Rev. J. H. Foster*

INVENTOR  
*Henry S. Esch*  
 BY *W. M. M. M.*  
 ATTORNEYS

No. 837,815.

PATENTED DEC. 4, 1906.

H. S. ESCH.  
SPRING MOTOR.

APPLICATION FILED JAN. 4, 1905.

2 SHEETS—SHEET 2.

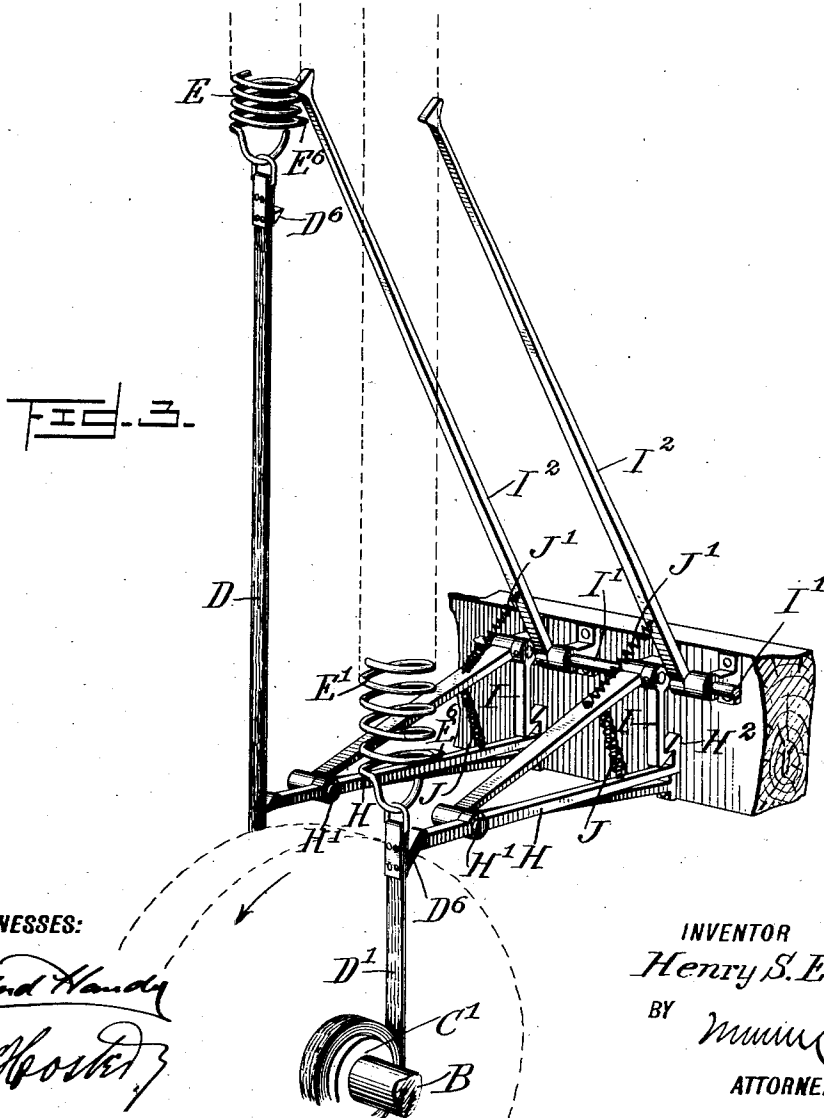
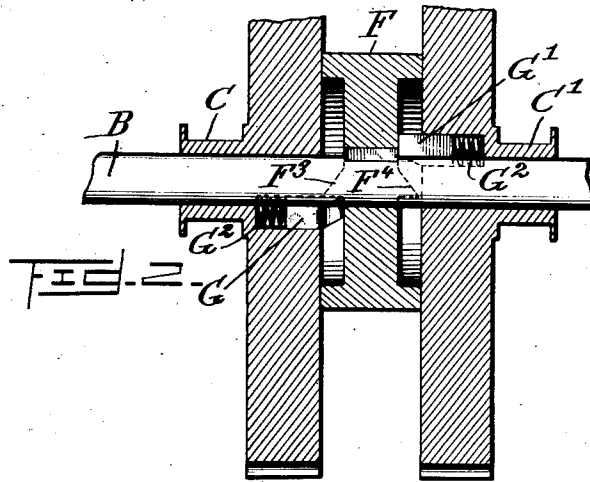

WITNESSES:

*L. Sanford Handy*  
*Henry Koster*

INVENTOR  
*Henry S. Esch*  
BY *Wm. M. Esch*  
ATTORNEYS

# UNITED STATES PATENT OFFICE.

HENRY S. ESCH, OF NEW YORK, N. Y.

## SPRING-MOTOR.

No. 837,815.

Specification of Letters Patent.

Patented Dec. 4, 1906.

Application filed January 4, 1905. Serial No. 239,565.

*To all whom it may concern:*

Be it known that I, HENRY S. ESCH, a citizen of the United States, and a resident of the city of New York, borough of Brooklyn, in the county of Kings and State of New York, have invented a new and Improved Spring-Motor, of which the following is a full, clear, and exact description.

The object of the invention is to provide a new and improved spring-motor capable of running for a considerable length of time without requiring rewinding of the springs and arranged to permit storing any desired amount of power for future use by the employment of a plurality of springs adapted to be thrown automatically and successively into action relative to the part to be rotated at a uniform power and speed.

The invention consists of novel features and parts and combinations of the same, as will be more fully described hereinafter and then pointed out in the claims.

A practical embodiment of the invention is represented in the accompanying drawings, forming part of this specification, in which similar characters of reference indicate corresponding parts in all the views.

Figure 1 is a side elevation of the improvement, the motor-casing or frame being shown in section and parts being broken out. Fig. 2 is an enlarged sectional side elevation of the shaft to be driven and two of the driving members on the said shaft. Fig. 3 is a perspective view of the automatic locking and releasing devices.

In the casing or frame A of the spring-motor is journaled the shaft B to be driven, and on this shaft are mounted loosely a number of drums C, C', C<sup>2</sup>, C<sup>3</sup>, C<sup>4</sup>, and C<sup>5</sup>, on which wind and unwind bands or belts D, D', D<sup>2</sup>, D<sup>3</sup>, D<sup>4</sup>, and D<sup>5</sup>, connected at their free ends with springs E, E', E<sup>2</sup>, E<sup>3</sup>, E<sup>4</sup>, and E<sup>5</sup>, attached to the casing A. Between adjacent drums C and C' is arranged a collar F, keyed or otherwise secured to the shaft B, and a similar collar F' is arranged between the drums C<sup>2</sup> and C<sup>3</sup> and a like collar F<sup>2</sup> is arranged between the drums C<sup>4</sup> and C<sup>5</sup>. Each of the collars F, F', and F<sup>2</sup> is provided on opposite faces of its web (see Figs. 2 and 4) with wedge-shaped lugs F<sup>3</sup> and F<sup>4</sup>, adapted to be engaged by the wedge-shaped free ends of catches G and G', mounted to slide lengthwise in suitable bearings on the correspond-

ing drums C, C', C<sup>2</sup>, C<sup>3</sup>, C<sup>4</sup>, and C<sup>5</sup>, each of the catches G and G' being pressed by a spring G<sup>2</sup> to engage the free end of the catch with the corresponding lug F<sup>3</sup> or F<sup>4</sup> and to allow the catch to slide in a reverse direction while the shaft B is rotated and during the time the corresponding drum C, C', C<sup>2</sup>, C<sup>3</sup>, C<sup>4</sup>, or C<sup>5</sup> is locked against rotation.

Each of the drums when under full tension—that is, when the corresponding belt is wound up and its spring is extended—is held against rotation, and for this purpose each of the belts is provided near its free end (see Fig. 3) with a lug D<sup>6</sup>, engaged by one end of a lever H, fulcrumed at H' on a suitable bracket carried by the main frame or casing A. The free end of each lever H is provided with a hook H<sup>2</sup>, adapted to be engaged by a catch I, secured on a shaft I', extending lengthwise and journaled in suitable bearings carried by the frame or casing A. On each shaft I' is secured an arm I<sup>2</sup>, arranged in such a manner that its free end extends in the path of a lug E<sup>6</sup>, formed on the lower end of the preceding spring, so that when a spring is nearly run out its lug E<sup>6</sup> acts on the arm I<sup>2</sup> to impart a swinging motion to the same to turn the corresponding shaft I', with a view to moving the catch I out of engagement with the hook H<sup>2</sup> of the lever H, normally locking the next following belt D' in position to hold the corresponding drum against rotation. Thus, as shown in Fig. 3, for instance, the second belt D' is held in a locked position by a locking and releasing device, which has its arm I<sup>2</sup> extending into the path of the lug E<sup>6</sup> of the spring E for the preceding belt D, and consequently when the belt D is released and the spring E exerts its pulling power on the belt D then the latter rotates the drum C and by its catch G in engagement with the lug F<sup>3</sup> rotates the collar F, and consequently the main shaft B. When the spring E is nearly run out, its lug E<sup>6</sup> imparts a swinging motion to the arm I<sup>2</sup> to turn the shaft I', with a view to releasing the lever H, thereby unlocking the belt D' to permit the spring E' to become active—that is, to pull on the belt D'—with a view to rotate the drum C' to give continuous rotary motion to the shaft B. When this spring E' is nearly run out, it acts on the arm I<sup>2</sup> of the locking and releasing device for the drum C<sup>2</sup>, and in a like manner this action is repeated throughout the series of drums,

belts, springs, and locking and releasing devices in the series.

Thus from the foregoing it will be seen that the locking and releasing device of one mechanism for driving the shaft B is controlled by the preceding driving device for the shaft B. It is understood that any desired number of such driving devices for the shaft B and locking and releasing devices may be employed on the shaft B, and hence I do not limit myself to any particular number of such devices.

Each lever H is pressed on by a light spring J to cause its free end to snap into engagement with the corresponding lug D<sup>6</sup>, and a similar spring J' presses each arm I<sup>2</sup> to hold the latter in the path of the lug E<sup>6</sup> of the preceding spring and to cause the catch I to snap into engagement with the hook H<sup>2</sup> of the lever H.

In order to govern the speed of the shaft B, a brake mechanism is provided, and for this purpose the shaft B carries a gear-wheel K, in mesh with a pinion K', secured on a shaft K<sup>2</sup>, journaled in a suitable bearing carried by the frame or casing A, and on the shaft K<sup>2</sup> is secured a brake-wheel K<sup>3</sup>, engaged by a brake-band K<sup>4</sup>, controlled by a screw-rod K<sup>5</sup>, to permit the operator to give more or less tension to the brake-band K<sup>4</sup>, according to the desired speed. The motion of the shaft B can be transmitted to other machinery by a pulley B', secured on the shaft and connected by belt with other mechanisms to be driven, or such a pulley K<sup>6</sup> may be secured on the shaft K<sup>2</sup>; but in either case I do not limit myself to this arrangement, as other devices may be employed for transmitting the rotary motion of the shaft B to other machinery.

In order to wind up any one of the belts D, D', D<sup>2</sup>, D<sup>3</sup>, D<sup>4</sup>, or D<sup>5</sup> on its corresponding drum C, C', C<sup>2</sup>, C<sup>3</sup>, C<sup>4</sup>, or C<sup>5</sup>, the following arrangement is made: A longitudinally-extending shaft L is journaled in suitable bearings on the casing or frame A, and on this shaft are mounted to turn and to slide lengthwise pinions N, adapted to mesh with gear-wheels N', secured or formed on the drum C, C', C<sup>2</sup>, C<sup>3</sup>, C<sup>4</sup>, or C<sup>5</sup>, and each of the said pinions N is connected with a suitable shifting device O under the control of the operator for moving the pinion in or out of mesh with the corresponding gear-wheel N'. When the shaft L is rotated and the pinion N or any number of the same are thrown in mesh with the corresponding gear-wheels N', then the latter are rotated to turn the drums, with a view to winding up their belts or bands D, D', D<sup>2</sup>, D<sup>3</sup>, D<sup>4</sup>, and D<sup>5</sup>.

The shaft L may be driven by power, but preferably by hand, and for this purpose the shaft L is provided with a gear-wheel L<sup>1</sup>, in mesh with a pinion L<sup>2</sup>, secured on a shaft L<sup>3</sup>, journaled in suitable bearings on the casing or frame A, and on the said shaft L<sup>3</sup> is secured a gear-wheel L<sup>4</sup>, in mesh with a pinion

L<sup>5</sup>, fastened on a shaft L<sup>6</sup>, carrying a crank-arm L<sup>7</sup>, under the control of the operator. On the shaft L<sup>6</sup> is secured a fly-wheel L<sup>8</sup>, which also may be used as a pulley, connected with other machinery whenever it is desired to turn the shaft L by power.

When it is desired to wind up any one or all of the belts or bands D, D', D<sup>2</sup>, D<sup>3</sup>, D<sup>4</sup>, and D<sup>5</sup>, it is only necessary for the operator to move the corresponding pinion N in mesh with its gear-wheel N' and then turn the crank-arm L<sup>7</sup>.

Presuming that all the belts D, D', D<sup>2</sup>, D<sup>3</sup>, D<sup>4</sup>, and D<sup>5</sup> are wound up on their drums C, C', C<sup>2</sup>, C<sup>3</sup>, C<sup>4</sup>, and C<sup>5</sup> and the springs E, E', E<sup>2</sup>, E<sup>3</sup>, E<sup>4</sup>, and E<sup>5</sup> are thus put under tension and the several driving mechanisms described are held in a locked position by the levers H and the first belt D is released, then the first spring E exerts a pull on the belt D to rotate the drum C, which by its catch G engaging the lug F<sup>3</sup> on the collar F rotates the latter, and consequently the shaft B. When the spring E is nearly run out—that is, at the time the belt D is almost completely unwound from the drum C—the lug E<sup>6</sup> acts on the first arm I<sup>2</sup> to cause a release of the lever H for the next belt D', so that the driving device, of which this belt D' forms a part, is set into action to give another impulse to the shaft B. When the spring E is run out, its drum C comes to a stop, and as the next drum C' is now in action the shaft B continues its rotation in the same direction by the transmission of power from the drum C' by the catch G', lug F<sup>4</sup>, and collar F, secured on the shaft B. This further rotation of the collar F does not affect the drum C, which now remains at a standstill, as the lug F<sup>3</sup> in passing the catch G simply pushes the same outward against the spring E<sup>2</sup> and then passes the same without rotating the drum C. When the spring E' has nearly run out, it actuates the next locking and releasing device for the belt D<sup>2</sup>, and the above-described operation is repeated for each of the driving devices.

In case it is desired to stop the operation of the shaft B at any time it is only necessary for the operator to turn the screw-rod K sufficiently to cause the brake-band K<sup>4</sup> to brake the wheel K<sup>3</sup> until the latter comes to a stop, and consequently with it the shaft B.

By the arrangement described any run-down spring can be rendered active without interfering with the running of the motor. It is understood that instead of the springs it is possible to use weights.

Thus from the foregoing it will be seen that the shaft B can be run for a considerable length of time without requiring rewinding of the springs unless it is desired to do so, and any desired amount of power can be stored to be used at one time or at different times, as the case may be.

Having thus described my invention, I claim as new and desire to secure by Letters Patent—

1. A spring-motor comprising a shaft to be driven, a plurality of drums loose on the said shaft, means for connecting each drum with the shaft, to rotate the latter when a drum is rotated, belts winding on the said drum, springs connected with the said belts, a locking device engaging each belt, and means for successively releasing the belts, the releasing means of one belt being controlled by the spring of the preceding belt.

2. A spring-motor comprising a shaft to be driven, a plurality of drums loose on the said shaft, means for connecting each drum with the shaft, to rotate the latter when a drum is rotated, belts winding on the said drum and each provided with a projection, springs connected with the said belts and provided with projections, and a locking and releasing device for each belt, controlled by a preceding spring, the said locking and releasing device consisting of a locking-lever for engaging the projection on the belt, a catch for engaging the locking-lever and an arm for turning the catch and arranged in the path of a projection on the preceding spring.

3. A spring-motor comprising a shaft to be driven, a plurality of drums loose on the said shaft, means for connecting each drum with the shaft, to rotate the latter when a drum is rotated, belts winding on the said drum and each provided with a projection, springs connected with the said belts and provided with projections, and a locking and releasing device for each belt, controlled by a preceding spring, the said locking and releasing device consisting of a locking-lever for engaging the projection on the belt, a catch for engaging the locking-lever, an arm for turning the catch and arranged in the path of a projection on the preceding spring, and springs for the said lever and arm.

4. A spring-motor provided with a part to be driven, a plurality of members loose on said part and under spring tension, a locking device for each member, means for successively releasing the members, the releasing means of one member being controlled by the preceding released rotating member, means for connecting a member with the said part, to turn the latter when the member is released and turning, and a winding-up device for each member, consisting of a shaft, a pinion mounted to slide on and to turn with the said shaft and a gear-wheel on each member, adapted to be engaged by the said pinion.

5. A spring-motor provided with a part to be driven, a plurality of members loose on said part and under spring tension, a locking de-

vice for each member, means for successively releasing the members, the releasing means of one member being controlled by the preceding released rotating member, means for connecting a member with the said part, to turn the latter when the member is released and turning, a winding-up device for each member, consisting of a shaft, a pinion mounted to slide on and to turn with the said shaft and a gear-wheel on each member, adapted to be engaged by the said pinion, and a manually-controlled shifting device for the said pinion.

6. In a spring-motor, a shaft to be driven, drums loose on the shaft, means for connecting the drums with the shaft, belts winding upon the drums and each provided with a projection at or near its end, springs connected with the belts and provided with projections, pivoted and spring-pressed locking-levers for engaging the projections of the belts, pivoted and spring-pressed arms extending in the path of the projection of the preceding spring, and catches controlled by the arms for engaging the locking-levers.

7. In a spring-motor, a shaft to be driven, drums loose on the shaft, means for connecting the drums with the shaft, belts winding on the drums and each provided with a beveled projection near its outer end, springs connected with the belts and provided with projections, pivoted locking-levers for engaging projections of the belts and provided with hooks, a rock-shaft, catches on the shaft for engaging the hooks of the locking-levers, and spring-pressed arms also on rock-shaft and each extending into the path of the projection of the preceding spring.

8. A spring-motor comprising a shaft to be driven, a plurality of spring-actuated members loose on the shaft, means for connecting the members with the shaft, a locking device for the members, and means for successively releasing the members, the releasing means of one member being controlled by the preceding member.

9. A spring-motor comprising a shaft to be driven, a plurality of drums loose on the shaft, means for connecting the drums with the shaft, belts winding on the drums, a tension device connected with each belt, means for locking the belts wound upon the drums, and means operated by the unwinding of the preceding belt for releasing the locking device of the following belt.

In testimony whereof I have signed my name to this specification in the presence of two subscribing witnesses.

HENRY S. ESCH.

Witnesses:

THEO. G. HOSTER,  
EVERARD B. MARSHALL.