

(19) World Intellectual Property Organization
International Bureau



(43) International Publication Date
11 June 2009 (11.06.2009)

PCT

(10) International Publication Number
WO 2009/073549 A1

(51) International Patent Classification:

A61N 1/32 (2006.01) A61F 2/00 (2006.01)
A61F 2/82 (2006.01) A61L 31/00 (2006.01)
A61F 2/30 (2006.01) A61N 1/30 (2006.01)

(21) International Application Number:

PCT/US2008/084960

(22) International Filing Date:

26 November 2008 (26.11.2008)

(25) Filing Language:

English

(26) Publication Language:

English

(30) Priority Data:

11/947,150 29 November 2007 (29.11.2007) US

(71) Applicant (for all designated States except US): BOSTON SCIENTIFIC LIMITED [IE/BB]; P.O. Box 1317, Seaston House, Hastings, Christ Church (BB).

(72) Inventors; and

(75) Inventors/Applicants (for US only): VANCAMP, Daniel [US/US]; 10838 185TH Ct. NW, Elk River, Minnesota 55330 (US). RADHAKRISHNAN, Rajesh [IN/US]; 17385 72nd Place N., Maple Grove, Minnesota 55311 (US). NIELSON, Eric [US/US]; 6646 119th Ave. SE, Bellevue, Washington 98006 (US). CHANDRASEKARAN, Verivada [US/US]; 4232 94th Ave. S.E., Mercer Island, Washington 98040 (US).

(74) Agents: SHIPSIDES, Geoffrey P. et al.; Fish & Richardson P.C., P.O. Box 1022, Minneapolis, Minnesota 55440-1022 (US).

(81) Designated States (unless otherwise indicated, for every kind of national protection available): AE, AG, AL, AM, AO, AT, AU, AZ, BA, BB, BG, BH, BR, BW, BY, BZ, CA, CH, CN, CO, CR, CU, CZ, DE, DK, DM, DO, DZ, EC, EE, EG, ES, FI, GB, GD, GE, GH, GM, GT, HN, HR, HU, ID, IL, IN, IS, JP, KE, KG, KM, KN, KP, KR, KZ, LA, LC, LK, LR, LS, LT, LU, LY, MA, MD, ME, MG, MK, MN, MW, MX, MY, MZ, NA, NG, NI, NO, NZ, OM, PG, PH, PL, PT, RO, RS, RU, SC, SD, SE, SG, SK, SL, SM, ST, SV, SY, TJ, TM, TN, TR, TT, TZ, UA, UG, US, UZ, VC, VN, ZA, ZM, ZW.

(84) Designated States (unless otherwise indicated, for every kind of regional protection available): ARIPO (BW, GH, GM, KE, LS, MW, MZ, NA, SD, SL, SZ, TZ, UG, ZM, ZW), Eurasian (AM, AZ, BY, KG, KZ, MD, RU, TJ, TM), European (AT, BE, BG, CH, CY, CZ, DE, DK, EE, ES, FI, FR, GB, GR, HR, HU, IE, IS, IT, LT, LU, LV, MC, MT, NL, NO, PL, PT, RO, SE, SI, SK, TR), OAPI (BF, BJ, CF, CG, CI, CM, GA, GN, GQ, GW, ML, MR, NE, SN, TD, TG).

Declarations under Rule 4.17:

- as to applicant's entitlement to apply for and be granted a patent (Rule 4.17(ii))
- as to the applicant's entitlement to claim the priority of the earlier application (Rule 4.17(iii))

[Continued on next page]

(54) Title: MEDICAL ARTICLES THAT STIMULATE ENDOTHELIAL CELL MIGRATION

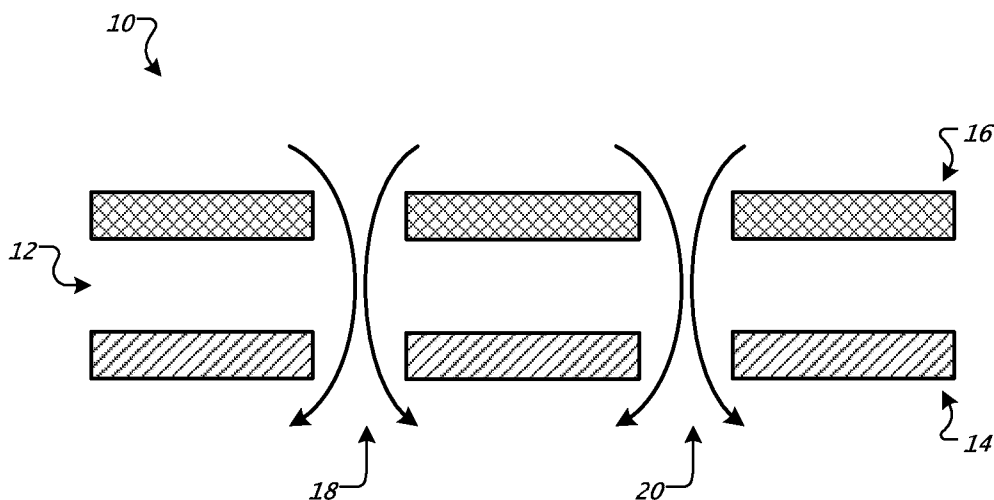

FIG. 1

(57) Abstract: A medical article that includes (a) an electronically conductive substrate having a specific conductivity of at least 1 ?S/cm and (b) a galvanic couple that includes a first member and a second member arranged in sufficient proximity to each other to generate a localized electric field under physiological conditions. The first and second members are selected such that the galvanic couple exhibits an average plateau current density of at least 25 microamps/cm² when short circuited in a zero resistance ammeter test at room temperature using a saline electrolyte.

WO 2009/073549 A1



Published:

— *with international search report*

MEDICAL ARTICLES THAT STIMULATE ENDOTHELIAL CELL MIGRATION

TECHNICAL FIELD

This invention relates to stimulating endothelial cell migration in medical articles.

BACKGROUND

5 Endothelial cells promote healing of damaged blood vessels within the body by promoting angiogenesis. In addition, endothelial cells can inhibit platelet adhesion and thrombus formation on blood-contacting surfaces. Directional or accelerated endothelial cell migration can be stimulated through application of an electric field.

SUMMARY

10 There is described a medical article that includes (a) an electronically conductive substrate having a specific conductivity of at least 1 $\mu\text{S}/\text{cm}$ and (b) a galvanic couple that includes a first member and a second member arranged in sufficient proximity to each other to generate a localized electric field under physiological conditions. The galvanic couple is chosen based upon the current density observed upon short circuiting at room temperature in 0.9% saline. Galvanic couples exhibiting a current density of at least 25 microamps/cm² are useful. The galvanic current is measured using the zero resistance ammeter method. In this test, each member of the couple is provided in the form of a foil measuring 5 cm x 5 cm, and included in a cell with 0.9% saline solution. The foils are spaced 4 cm apart. The cell is then short circuited and the current density on each foil measured at room temperature. The average of the two current density values is the average plateau current density of the galvanic couple.

25 The members of the galvanic couple act as electrodes, and could generate a localized electric field in the presence of ion-containing fluids such as plasma and blood. The localized electric field could promote endothelial cell migration under physiological conditions that the article would encounter upon implantation within a patient's body (in the case of implantable medical devices) or on the surface of the patient's body (in the case of external wound healing articles), thus eliminating the need for an external voltage source. Endothelializing the surface of the article, in

turn, could promote healing. By selectively placing the members of the galvanic couple on the device, the pattern of endothelialization could be controlled.

As used herein, "metal" means both elemental metals and compounds such as oxides, chlorides, carbonates, and the like.

5 The details of one or more embodiments are set forth in the accompanying drawings and the description below. Other features, objects, and advantages will be apparent from the description and drawings, and from the claims.

DESCRIPTION OF DRAWINGS

10 FIG. 1 is a cross-sectional view of an implantable medical device having a porous structure that includes a galvanic couple.

FIG. 2 is a perspective view of a strut of a stent that includes a galvanic couple.

Like reference symbols in the various drawings indicate like elements.

DETAILED DESCRIPTION

15 There is described a medical article that includes an electronically conductive substrate having a specific conductivity of at least 1 $\mu\text{S}/\text{cm}$, and a galvanic couple, as described in the Summary, above. The galvanic couple, in the presence of ion-containing fluids such as plasma a blood, forms an electrochemical cell in which the members of the couple act as electrodes and the fluid acts as an ion-conducting
20 electrolyte. The localized electric field that the cell generates could promote endothelial cell migration under physiological conditions, thereby effecting selective placement of endothelial cells on designated portions of the surface of the medical article. Examples of suitable medical articles include implantable articles such as stents, vascular grafts, heart valves, and indwelling catheters. Other examples of
25 suitable medical articles include external wound healing articles such as bandages and wound dressings.

The electronically conductive substrate, as noted above, has a specific conductivity of at least 1 $\mu\text{S}/\text{cm}$, and could be at least 1 mS/cm . Examples of suitable materials for the substrate could include metals (e.g., stainless steel, cobalt-chromium
30 alloys, platinum enhanced stainless steel alloys, Nitinol alloys, and the like), electrically conductive polymers (e.g., polyvinylidene fluoride, polyaniline, and the

like), and electrically conductive polymer composites (e.g., polymer matrices containing electrically conductive particles, wires, meshes, or the like).

The members of the galvanic couple are selected with the objective of maximizing the strength of the localized electric field. This objective could be achieved by selecting the members of the galvanic couple such that the couple exhibits an average plateau current density of at least 25 microamps/cm² (preferably at least 250 microamps/cm²) when short circuited according to the zero resistance ammeter test described in the Summary, above. Such current densities, in turn, could be achieved by selecting the members of the galvanic couple such that the first member of the galvanic couple is less electrochemically active than the second member of the galvanic couple.

Suitable materials for the first member of the galvanic couple could include, for example, noble metals such as platinum, iridium, and ruthenium, as well as oxides of these metals (e.g., iridium oxide). Other examples could include refractory metals such as titanium, hafnium, zirconium, and niobium, and oxides thereof. Suitable materials for the second member of the galvanic couple could include, for example, alkali metals, alkaline earth metals (e.g., magnesium or calcium), transition metals such as zinc, as well as compounds of these metals such as oxides, carbonates, chlorides, and the like. Specific examples of suitable galvanic couples could include:

- (a) Pt/Zn;
- (b) Iridium Oxide/Zn;
- (c) Iridium Oxide/Mg; and
- (d) Ruthenium Oxide/Zn.

When the Pt/Zn couple was evaluated in the zero resistance ammeter test, a current density of 0.07 mA/cm² was measured on the platinum foil and a current density of 0.35 mA/cm² was measured on the zinc foil, yielding an average plateau current density of 0.21 mA/cm² (210 μA/cm²).

One or both members of the galvanic couple could be deposited on the electronically conductive substrate using a variety of techniques, including electrodeposition, electrochemical metallization, PVD, CVD, IBAD, FIB, micro-contact printing, self assembly, micro-molding in capillaries, e-beam lithography, photolithography, and the like. Alternatively, one or both members of the galvanic

couple could be provided in the form of particles, meshes, or foils. The particles, meshes, and foils, in turn, could be embedded within a matrix.

Fig. 1 illustrates one embodiment of a medical article incorporating a galvanic couple on an electronically conductive substrate. As shown in Fig. 1, medical article 10 includes an electronically conductive substrate 12 (e.g., a polymer such as polyvinylidene fluoride or a porous metal). The inner surface of substrate 12 is provided with the first member 14 of a galvanic couple (e.g., a platinum or iridium oxide layer), while the outer surface of substrate 12 is provided with the second member 16 of the galvanic couple (e.g., a zinc layer). Substrate 12 also includes a plurality of pores 18, 20. When article 10 is in contact with physiological fluids such as blood or saline (e.g., when the article is implanted within a patient's body), current could flow between members 16 and 14 (as shown by the arrows in Fig. 1). The current flow, in turn, could stimulate endothelial cell migration from, e.g., surrounding vessel walls to deposit the cells on the inner surface of substrate 12.

Fig. 2 illustrates another embodiment in which a stent strut 22 is provided on one surface with the first member 24 of a galvanic couple (e.g., a conformal iridium oxide layer) and on another surface with the second member 26 of the galvanic couple (e.g., a zinc layer). Upon exposure to blood or plasma, current could flow between members 26 and 24 (as shown by the arrows in Fig. 2) to deposit endothelial cells on strut 22.

In the case of medical articles such as wound dressings or bandages designed for external application, the members of the galvanic couple could be provided in the form of fibers or particles incorporated within the dressing or bandage. For example, the fibers could be interwoven with the fibers of a gauze pad. Alternatively, the members could be incorporated in semi-porous pouches. The dressing or bandage could further include a conductive gel to improve current flow.

The members of the galvanic couple could be arranged on the medical article in the form of a pattern. By adjusting the shape and dimensions of the pattern, it may be possible to deposit endothelial cells on specific, pre-determined portions of the medical article. The members could be deposited along the entire length or surface of the medical article, or confined to specific portions of the article. In addition, more than one type of galvanic couple could be incorporated in the article.

A number of embodiments have been described. Nevertheless, it will be understood that various modifications may be made without departing from the spirit and scope of the invention. Accordingly, other embodiments are within the scope of the following claims.

WHAT IS CLAIMED IS:

- 1 1. A medical article comprising (a) an electronically conductive substrate having a
2 specific conductivity of at least 1 $\mu\text{S}/\text{cm}$ and (b) a galvanic couple that comprises
3 a first member and a second member arranged in sufficient proximity to each
4 other to generate a localized electric field under physiological conditions, wherein
5 the first and second members are selected such that the galvanic couple exhibits
6 an average plateau current density of at least 25 microamps/ cm^2 when short
7 circuited in a zero resistance ammeter test at room temperature using a saline
8 electrolyte.
- 1 2. A medical article according to claim 1 wherein the first and second members are
2 selected such that the galvanic couple exhibits an average plateau current density
3 of at least 250 microamps/ cm^2 when short circuited in a zero resistance ammeter
4 test at room temperature using a saline electrolyte.
- 1 3. A medical article according to claim 1 wherein the substrate has a specific
2 conductivity of at least 1 mS/cm.
- 1 4. A medical article according to claim 1 wherein the first member of the galvanic
2 couple comprises a noble metal.
- 1 5. A medical article according to claim 4 wherein the noble metal is selected from
2 the group consisting of platinum, iridium, ruthenium, and combinations thereof.
- 1 6. A medical article according to claim 1 wherein the first member of the galvanic
2 couple comprises a refractory metal.
- 1 7. A medical article according to claim 6 wherein the refractory metal is selected
2 from the group consisting of titanium, hafnium, zirconium, and niobium, and
3 combinations thereof.
- 1 8. A medical article according to claim 1 wherein the second member of the galvanic
2 couple is a metal selected from the group consisting of alkali metals, alkaline earth
3 metals, zinc, and combinations thereof.

- 1 9. A medical article according to claim 8 wherein the second member of the galvanic
2 couple comprises zinc.
- 1 10. A medical article according to claim 1 wherein the first member of the galvanic
2 couple is selected from the group consisting of platinum, iridium, ruthenium, and
3 combinations thereof, and the second member of the galvanic couple is selected
4 from the group consisting of zinc, magnesium, and combinations thereof.
- 1 11. A medical article according to claim 1 wherein the substrate is selected from the
2 group consisting of metals, electrically conductive polymers, electrically
3 conductive polymer composites, and combinations thereof.
- 1 12. A medical article according to claim 1 wherein the substrate comprises an outer
2 surface, an inner surface, and pores extending between the outer and inner
3 surfaces, wherein one of the members of the galvanic couple is provided on the
4 outer surface of the substrate and the other member of the galvanic couple is
5 provided on the inner surface of the substrate.
- 1 13. A medical article according to claim 1 wherein the one of the members of the
2 galvanic couple is provided in the form of a layer deposited on the substrate and
3 the other member of the galvanic couple is provided in the form of particles in a
4 matrix deposited on the substrate.
- 1 14. A medical article according to claim 13 wherein the matrix comprises a
2 biodegradable polymer or metal matrix.
- 1 15. A medical article according to claim 1 wherein the first and second members of
2 the galvanic couple are deposited on the substrate in the form of a pattern along
3 the length of the article.
- 1 16. A medical article according to claim 1 wherein the article is an implantable
2 medical device.
- 1 17. A medical article according to claim 16 wherein the implantable medical device is
2 a stent.

- 1 18. A medical article according to claim 16 wherein the implantable medical device is
2 a vascular graft.
- 1 19. A medical article according to claim 1 wherein the article is an external wound
2 healing article.
- 1 20. A medical article according to claim 19 wherein the article is a bandage in which
2 the galvanic couple is incorporated in a fabric arranged in electrical contact with
3 the electrically conductive substrate.
- 1 21. An implantable medical device comprising (a) an electronically conductive
2 substrate having a specific conductivity of at least 1 mS/cm selected from the
3 group consisting of metals, electrically conductive polymers, electrically
4 conductive polymer composites, and combinations thereof; and (b) a galvanic
5 couple that comprises a (i) first member selected from the group consisting of
6 platinum, iridium, ruthenium, and combinations thereof, and (ii) a second member
7 selected from the group consisting of zinc, magnesium, and combinations thereof,
8 wherein the first and second members are arranged in sufficient proximity to each
9 other to generate a localized electric field under physiological conditions, and the
10 first and second members are selected such that the galvanic couple exhibits an
11 average plateau current density of at least 250 microamps/cm² when short
12 circuited in a zero resistance ammeter test at room temperature using a saline
13 electrolyte.
- 1 22. An implantable medical device according to claim 21 wherein the device is a
2 stent.



1/1

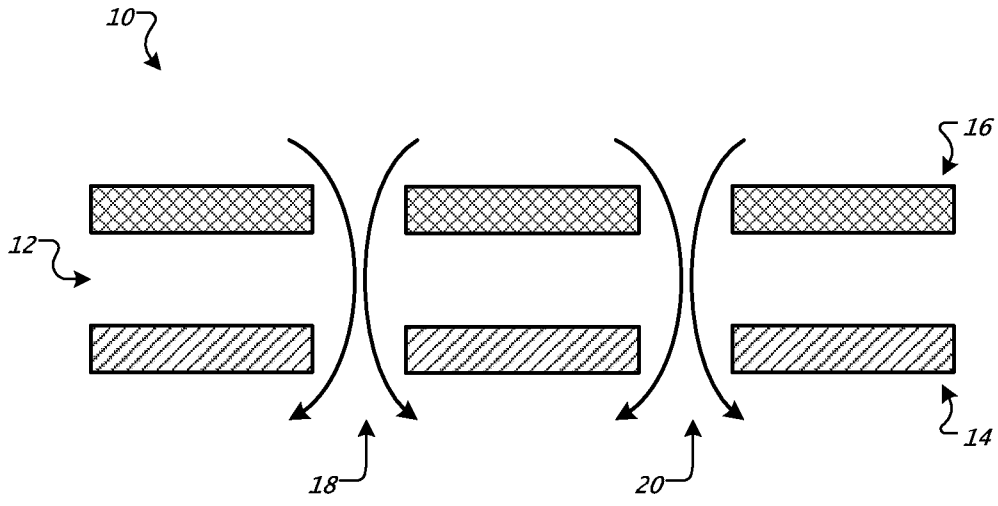

FIG. 1

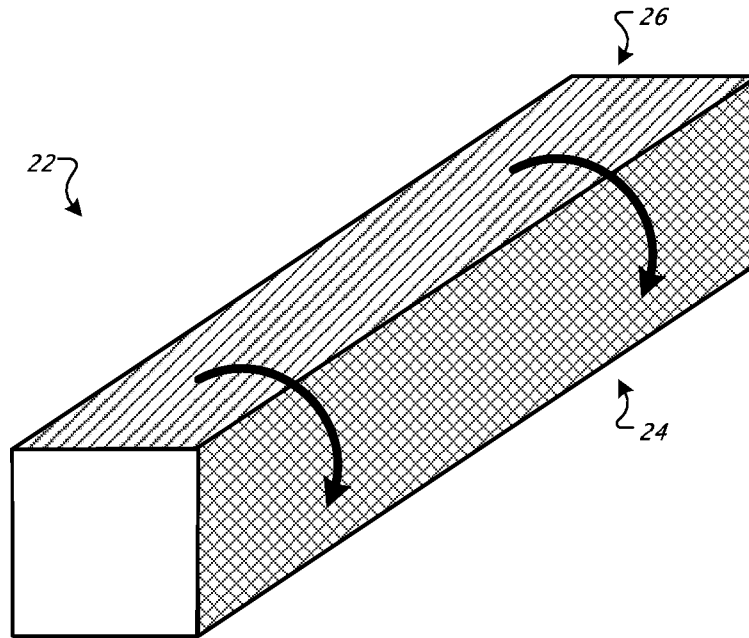

FIG. 2



INTERNATIONAL SEARCH REPORT

International application No PCT/US2008/084960

A. CLASSIFICATION OF SUBJECT MATTER
 INV. A61N1/32 A61F2/82 A61F2/30 A61F2/00 A61L31/00
 ADD. A61N1/30

According to International Patent Classification (IPC) or to both national classification and IPC

B. FIELDS SEARCHED
 Minimum documentation searched (classification system followed by classification symbols)
 A61F A61N A61L

Documentation searched other than minimum documentation to the extent that such documents are included in the fields searched

Electronic data base consulted during the international search (name of data base and, where practical, search terms used)
 EPO-Internal

C. DOCUMENTS CONSIDERED TO BE RELEVANT

Category*	Citation of document, with indication, where appropriate, of the relevant passages	Relevant to claim No.
X	NL 7 707 627 A (SEIDERMAN MAURICE) 14 July 1978 (1978-07-14) In particular page 8, line 6 - page 11, line 18; figures 1-3	1-12,15
X	US 2006/015052 A1 (CRISP WILLIAM E [US]) 19 January 2006 (2006-01-19) paragraphs [0009], [0013] - [0015] paragraphs [0037] - [0045]; figures 1-3	1-4,8,9, 11,19,20
X	US 2007/270942 A1 (THOMAS RICHARD [US]) 22 November 2007 (2007-11-22)	1-11, 15-18, 21,22
Y	paragraphs [0010] - [0018] paragraphs [0052] - [0059]; table 1 ----- -/--	12-14

Further documents are listed in the continuation of Box C. See patent family annex.

* Special categories of cited documents :

A document defining the general state of the art which is not considered to be of particular relevance	*T* later document published after the international filing date or priority date and not in conflict with the application but cited to understand the principle or theory underlying the invention
E earlier document but published on or after the international filing date	*X* document of particular relevance; the claimed invention cannot be considered novel or cannot be considered to involve an inventive step when the document is taken alone
L document which may throw doubts on priority claim(s) or which is cited to establish the publication date of another citation or other special reason (as specified)	*Y* document of particular relevance; the claimed invention cannot be considered to involve an inventive step when the document is combined with one or more other such documents, such combination being obvious to a person skilled in the art.
O document referring to an oral disclosure, use, exhibition or other means	*&* document member of the same patent family
P document published prior to the international filing date but later than the priority date claimed	

Date of the actual completion of the international search 18 March 2009	Date of mailing of the international search report 26/03/2009
--	--

Name and mailing address of the ISA/ European Patent Office, P.B. 5818 Patentlaan 2 NL - 2280 HV Rijswijk Tel. (+31-70) 340-2040, Fax: (+31-70) 340-3016	Authorized officer Loveniers, Kris
--	---

INTERNATIONAL SEARCH REPORT

International application No
PCT/US2008/084960

C(Continuation). DOCUMENTS CONSIDERED TO BE RELEVANT		
Category*	Citation of document, with indication, where appropriate, of the relevant passages	Relevant to claim No.
X	<p>WO 2005/030026 A (TURNER JOSEF [IL]) 7 April 2005 (2005-04-07) page 1, lines 10-12 page 3, line 11 - page 4, line 16 page 8, lines 1-13; figure 2 page 11, line 24 - page 12, line 8; figures 5,6</p> <p>-----</p>	1-4, 8, 9, 11
X	<p>US 4 314 554 A (GREATBATCH WILSON) 9 February 1982 (1982-02-09) column 6, line 24 - column 7, line 47; figure 3</p> <p>-----</p>	1
Y	<p>WO 03/063733 A (RADI MEDICAL SYSTEM AB [SE]; TENERZ LARS [SE]; VON MALMBORG PAER [SE];) 7 August 2003 (2003-08-07) abstract page 5, line 20 - page 6, line 23 page 8, line 16 - page 9, line 13; figure 5</p> <p>-----</p>	12-14
A	<p>WO 2007/013065 A (GROSS YOSSI [IL]) 1 February 2007 (2007-02-01) page 14, lines 13-16 page 17, lines 14-25; figure 1</p> <p>-----</p>	16-18, 21,22
A	<p>WO 2005/023361 A (POWER PAPER LTD [IL]) 17 March 2005 (2005-03-17) abstract page 2, line 22 - page 3, line 25 figure 2</p> <p>-----</p>	19,20

INTERNATIONAL SEARCH REPORT

Information on patent family members

International application No

PCT/US2008/084960

Patent document cited in search report	A	Publication date	Patent family member(s)	Publication date
NL 7707627	A	14-07-1978	AT 367300 B AU 2691077 A BE 856603 A1 CA 1113396 A1 DE 2730990 A1 FR 2377204 A1 JP 53089295 A	25-06-1982 18-01-1979 31-10-1977 01-12-1981 13-07-1978 11-08-1978 05-08-1978
US 2006015052	A1	19-01-2006	US 2006015053 A1	19-01-2006
US 2007270942	A1	22-11-2007	EP 2032075 A1 WO 2007136965 A1	11-03-2009 29-11-2007
WO 2005030026	A	07-04-2005	NONE	
US 4314554	A	09-02-1982	AU 6041880 A CA 1164531 A1 DE 3020200 A1 FR 2461506 A1 GB 2053687 A JP 56015762 A NL 8003323 A SE 8001238 A	22-01-1981 27-03-1984 12-02-1981 06-02-1981 11-02-1981 16-02-1981 20-01-1981 17-01-1981
WO 03063733	A	07-08-2003	AT 362741 T DE 60220319 T2 EP 1482864 A1 JP 2005515831 T	15-06-2007 17-01-2008 08-12-2004 02-06-2005
WO 2007013065	A	01-02-2007	EP 1909694 A2 JP 2009502302 T US 2008033501 A1 US 2008215117 A1	16-04-2008 29-01-2009 07-02-2008 04-09-2008
WO 2005023361	A	17-03-2005	EP 1673139 A2 JP 2007504882 T	28-06-2006 08-03-2007