

J. HAWORTH.
Motor for Sewing-Machines.

No. 203,035.

Patented April 30, 1878.

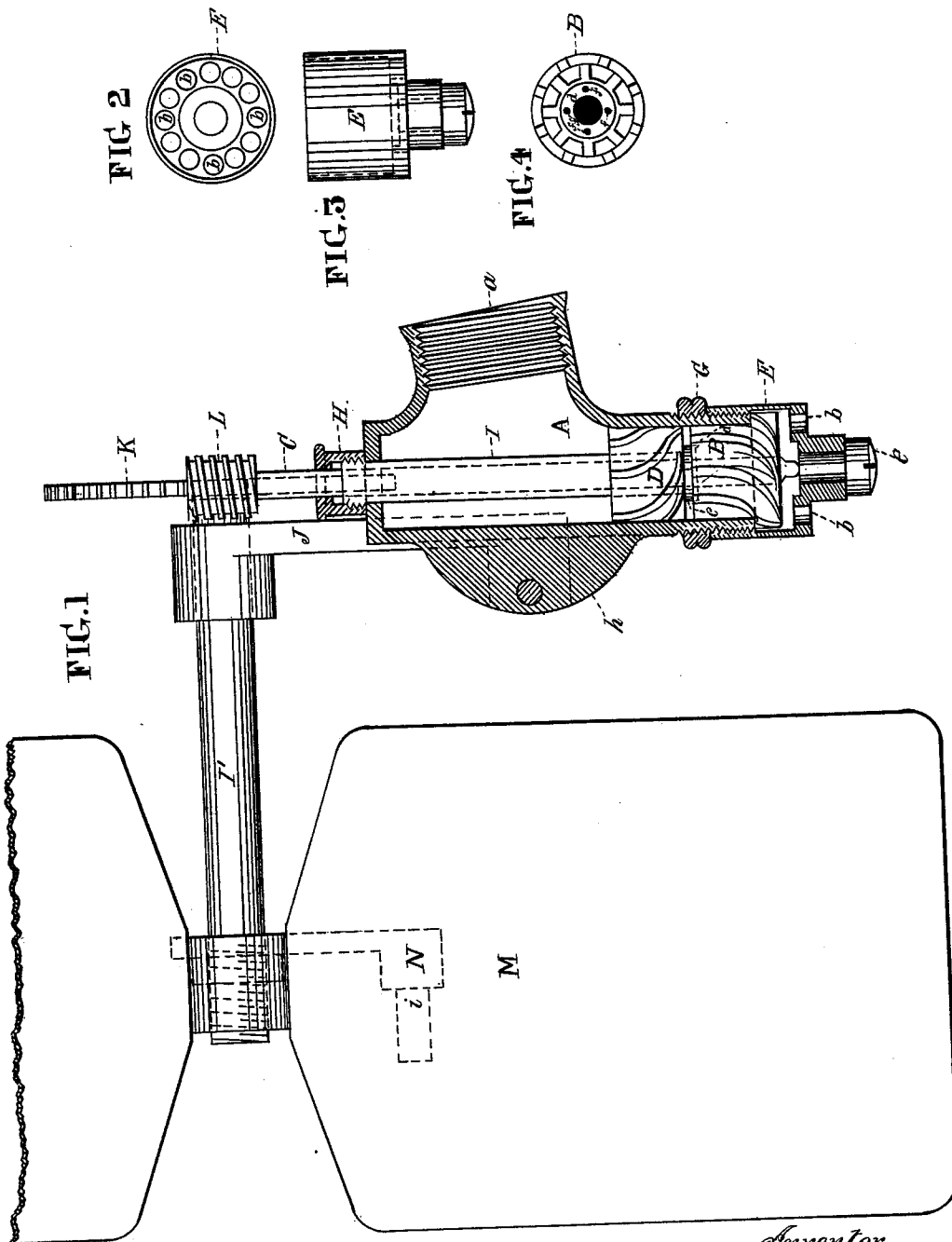

Witnesses
 Thomas J. Bewley.
 S. R. Mallett.

Inventor
 John Haworth
 per Stephen Utich Attorney

J. HAWORTH.
Motor for Sewing-Machines.

No. 203,035.

Patented April 30, 1878.

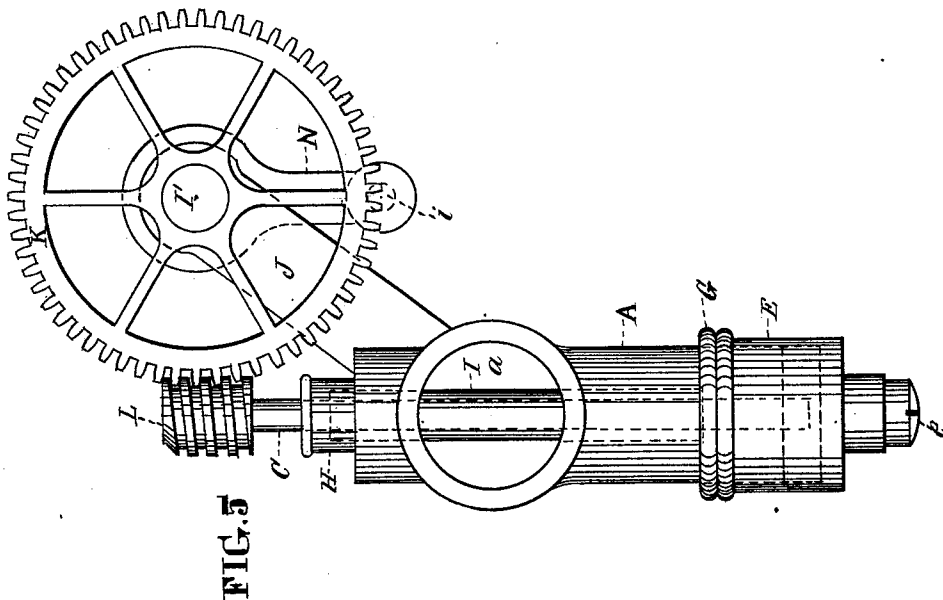

Witnesses

Thomas G. Dewley.
S. H. Mallett.

Inventor

John Howarth
per Stephen Urick Attorney

UNITED STATES PATENT OFFICE.

JOHN HAWORTH, OF PHILADELPHIA, PENNSYLVANIA.

IMPROVEMENT IN MOTORS FOR SEWING-MACHINES.

Specification forming part of Letters Patent No. **203,035**, dated April 30, 1878; application filed October 8, 1877.

To all whom it may concern:

Be it known that I, JOHN HAWORTH, of the city and county of Philadelphia, in the State of Pennsylvania, have invented a new and useful Improvement in Motors for Sewing-Machines, &c., which improvement is fully set forth in the following specification and the accompanying drawings, in which—

Figure 1 is a side elevation of my improved motor, partly in section. Fig. 2 is a top view of the cap D. Fig. 3 is a side elevation of the same. Fig. 4 is a top view of the water-wheel B. Fig. 5, Sheet No. 2, is a side elevation of the motor at right angles to Fig. 1.

Like letters of reference in all the figures indicate the same parts.

The nature of my invention consists of the following particulars: The motor is on the turbine principle. It has a permanent reacting-chute in a cylindrical case, and a water-wheel beneath the chute on a vertical shaft, which revolves at its lower end in the hub of the chute and at its upper end in the upper end of the cylindrical case. This part of the case is made solid with the cylindrical portion, for the sake of simplicity and cheapness of construction. The water-wheel extends partly below the lower end of the case, and is enlarged in its diameter at this point, and is covered by a cap, which is screwed onto this end of the case and fits the peripheral edges of the buckets thus inclosed. The object of this enlargement of the wheel is fully described hereinafter. The bottom of the cap is perforated for the passage of water, as it leaves the bottom of the wheel, to the waste-pipe. (Not seen in the drawings.) The cap is provided with a set-screw for adjusting the water-wheel to the chute; and in accommodation to this adjustment, the cap, by means of its screw-connection with the case, is adjusted on the latter. There is an adjustable nut on the case immediately above the cap, for locking the latter in its adjusted position.

In order to prevent any waste-water passing up around the water-wheel shaft to the stuffing-box, the shaft is inclosed by means of a tube, which is connected at its upper end with the upper end of the case, and at its lower end with the chute, as shown in the patent of James Haworth and W. N. Newell, dated April 17, 1877,

No. 189,624. The use of the tube is therefore not new in this application; but in order to prevent the water passing from between the upper side of the water-wheel and the lower side of the chute up the tube to the stuffing-box, I form a central projection on the lower side of the chute and a corresponding recess in the upper side of the wheel, and perforate the latter from the recess to the lower side of the wheel, to conduct the water from between the chute and the wheel.

The upper end of the wheel-shaft is provided with a worm-wheel, which gears into a spur-wheel of a driving-shaft, which is supported by an arm projected from the case, as hereinafter described.

In the drawings, A represents the water-wheel case, which is of cylindrical form, and has an opening, *a*, at one side, to receive the water from the feed-pipe. B is the water-wheel on the vertical shaft C, and D the reacting-chute, under which it runs. The chute is permanently connected with the case A. The lower bearing of the shaft C is in the hub of the chute, and its upper bearing in the upper end of the case. This end of the case is cast solid with it, for the sake of simplicity and cheapness of construction. The water-wheel B extends partly below the lower end of the case A, and is enlarged on this part and fits the cap E, which is screwed onto the lower end of the case. The object of this enlargement of the case is to utilize the force of the water, that rapidly descends down the peripheral surface of the case, by causing it to strike the extended surfaces of the buckets of the wheel B. The lower side of the cap E has perforations *b*, for the passage of the water to the waste-pipe, (not seen in the drawings,) the pipe being connected to the cap. The cap is provided with the set-screw *e*, for adjusting the wheel B to the chute D, the lower end of the shaft C of the wheel resting on the end of the screw; and to suit such adjustment, the height of the cap E is adjusted by means of its screw-connection with the case A. The cap is locked in its adjusted position by means of the nut G on the case A. (Seen in Figs. 1 and 5.)

To prevent the water passing up to the stuffing-box H, I surround the wheel-shaft C with

the tube I, the lower end being connected with the chute D and the upper end with the upper end of the case A, as seen in Fig. 1, the tube projecting above the end of the case, to connect the stuffing-box therewith.

To prevent the water passing up the tube from between the chute and the wheel, there is a central projection, *c*, on the lower side of the chute, which fits the depression *d* in the upper side of the wheel B; and from this depression there are perforations *f* through the hub of the wheel, for the passage of the water to the bottom of the cap E, from whence it passes through perforations *b* in its bottom into the waste-pipe along with the spent water from the water-wheel.

I' is the driving-shaft, which is supported at one end in the upper end of the arm J, the lower end of which is bolted to the flange *h* of the case A. This end of the shaft has a geared connection with the upper end of the water-wheel shaft C by means of the spur-wheel K and worm-wheel L. M is a fan on the opposite end of the shaft to that on which the spur-wheel is placed, for fanning the operator of a sewing or other machine which is driven by the motor. When the fan is not used, the sewing-machine, instead of being driven by a band connected with the motor, may be driven by connecting the pin *i* of the arm N of the shaft I with a hole in the fly-wheel of such machine, or with a lug of the wheel. The fan M

and the arm N may be both used at the same time by making the shaft I long enough to admit of the fan being arranged on the middle portion of the shaft.

I claim as my invention—

1. The cylindrical case A, having its upper end cast solid with the cylindrical part, and provided with the stuffing-box H, substantially as and for the purpose set forth.

2. The adjustable cap E, having perforations *b* in its lower side, in combination with the lower end of the case A and the water-wheel B, substantially as and for the purpose set forth.

3. The water-wheel B, enlarged at its lower end to project under the lower end of the case A, in combination with the cap E, substantially in the manner and for the purpose set forth.

4. The adjustable nut G, in combination with the case A and cap E, for locking the latter in its adjusted position, substantially as set forth.

5. The chute D, having a central projection, *c*, in combination with the wheel B, having a corresponding recess, *d*, and perforations *f*, for conducting the water from between the chute and the wheel, substantially as set forth.

JOHN HAWORTH.

Witnesses:

STEPHEN USTICK,
THOMAS J. BEWLEY.