

S. VARNEY.
CLOTHES WRINGER.
APPLICATION FILED JULY 7, 1908.

915,513.

Patented Mar. 16, 1909.

2 SHEETS—SHEET 1.

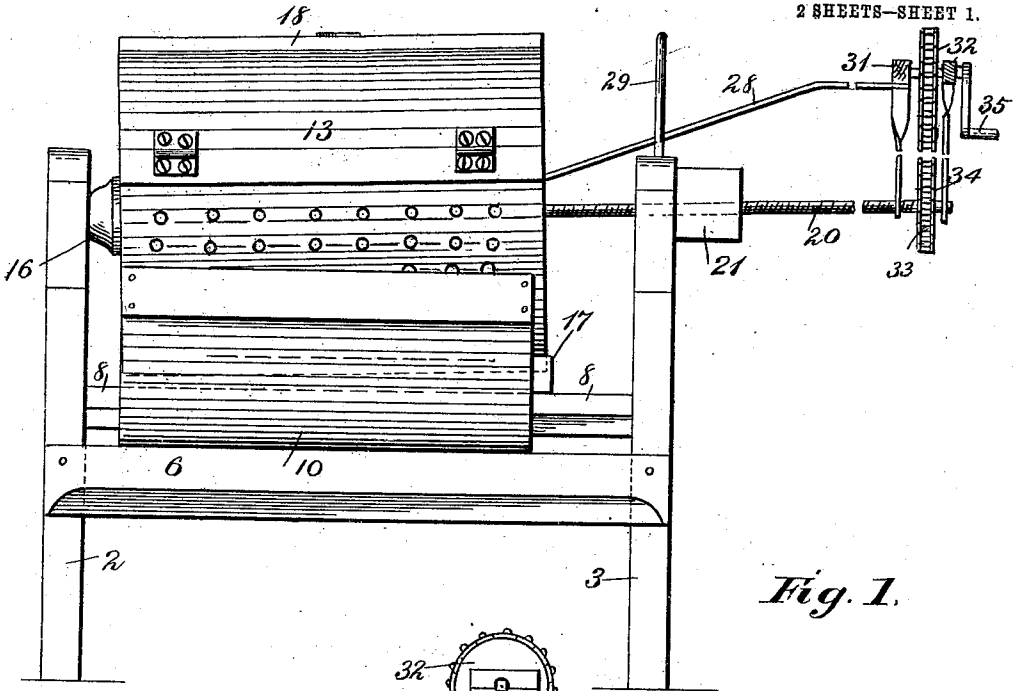

Fig. 1.

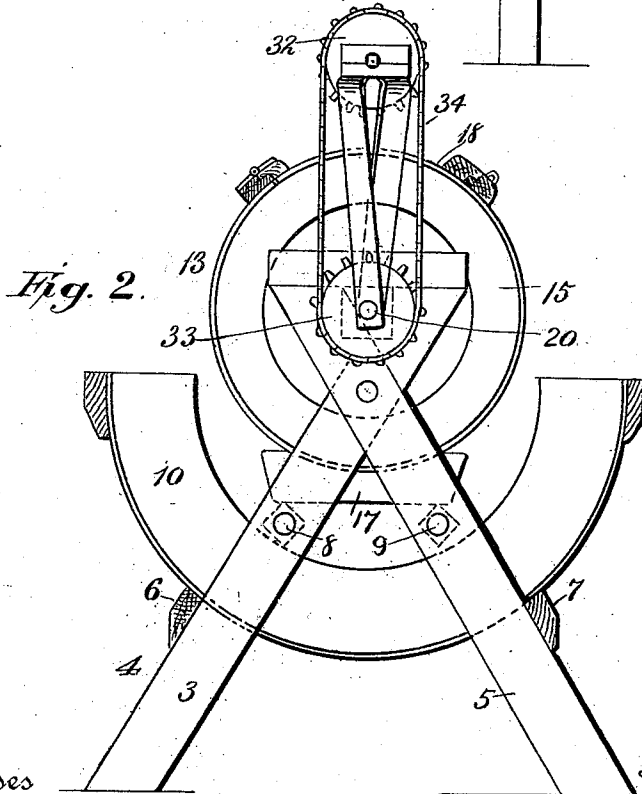

Fig. 2.

Witnesses
J. L. Orrand
C. H. Giesbauer.

Inventor
Sylvester Varney,

By *A. B. Wilson & Co.*
Attorneys

915,513.

S. VARNEY.
CLOTHES WRINGER.
APPLICATION FILED JULY 7, 1908.

Patented Mar. 16, 1909.

2 SHEETS—SHEET 2.

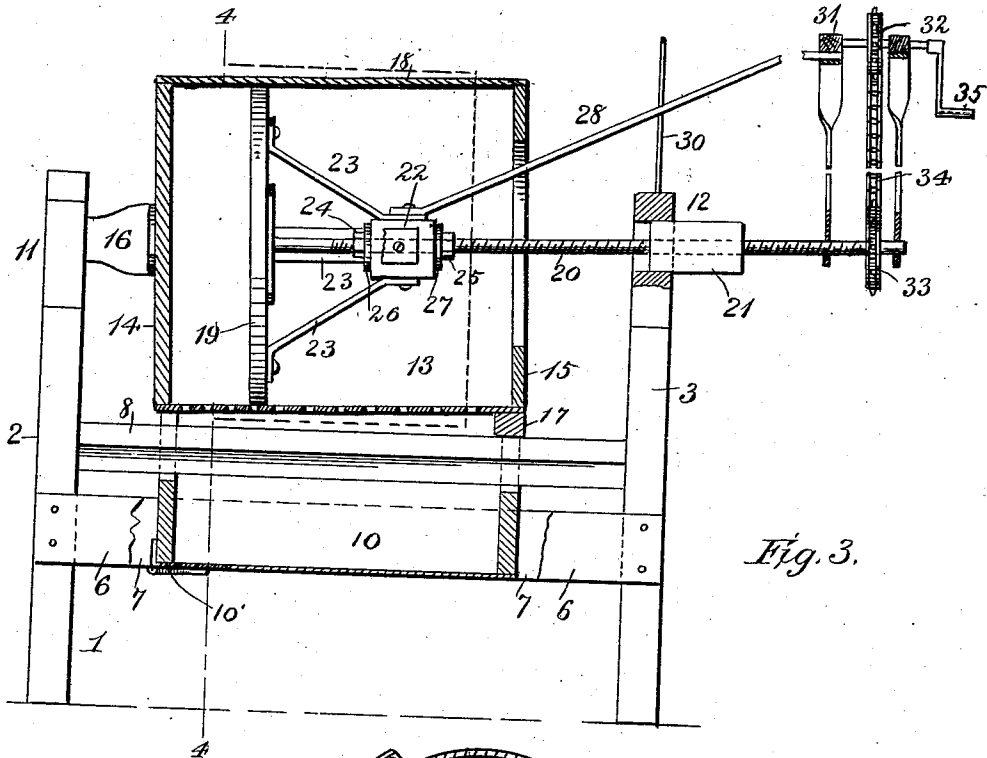

Fig. 3.

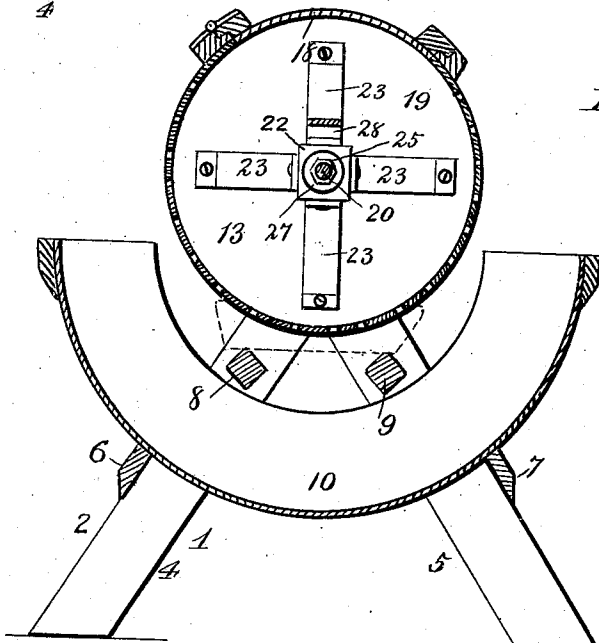

Fig. 4.

Witnesses
F. L. Orrand
C. H. Griesbauer.

Inventor
Sylvester Varney.

By *A. B. Wilson & Co.*
Attorneys

UNITED STATES PATENT OFFICE.

SYLVESTER VARNEY, OF SCARVILLE, IOWA.

CLOTHES-WRINGER.

No. 915,513.

Specification of Letters Patent.

Patented March 16, 1909.

Application filed July 7, 1908. Serial No. 442,371.

To all whom it may concern:

Be it known that I, SYLVESTER VARNEY, a citizen of the United States, residing at Scarville, in the county of Winnebago and State of Iowa, have invented certain new and useful Improvements in Clothes-Wringers; and I do declare the following to be a full, clear, and exact description of the invention, such as will enable others skilled in the art to which it appertains to make and use the same.

This invention relates to an improved clothes wringer.

The object of the invention is to provide a machine for removing water from a large number of articles in a single operation without any wringing or twisting such as would be liable to injure the clothes, and is especially adapted for use in laundries.

With these and other objects in view, the invention consists of certain novel features of construction, combination and arrangement of parts as will be more fully described and particularly pointed out in the appended claims.

In the accompanying drawings, Figure 1 represents a side elevation of this improved machine; Fig. 2 is a front end elevation thereof; Fig. 3 is a longitudinal, vertical section partly in elevation; and Fig. 4 is a transverse section taken on line 4-4 of Fig. 3.

In the embodiment illustrated a supporting structure, 1, is shown, preferably constructed of two end members, 2 and 3, each of which is preferably formed of two crossed bars, 4 and 5, bolted together and recessed on their inner faces to fit one on the other with their outer faces flush with each other. The lower ends of the members, 2 and 3, are braced and connected by side bars, 6 and 7, and similar bars, 8 and 9, connect said end members at a point above the bars 6 and 7, with spaces formed between them to receive a drain water receptacle to be described. This drain receptacle, 10, is preferably made as shown in the form of a semi-cylindrical member having cut-out portions at the ends thereof, said end members being of a width to fit between the side bars of the supporting structure by means of which it is held securely in position without any extraneous means being necessary. Two blocks, 11 and 12, are mounted in the upper ends of the end members, 2 and 3, for a purpose to be described.

The clothes receptacle, 13, is mounted be-

tween the end members, 2 and 3, and is preferably made in the form of a cylindrical casing, having the round body portion thereof perforated to permit the passage of water therethrough. One end of this cylinder is closed by means of a solid head, 14, and the other end is provided with an annular head, 15, secured therein for a purpose to be described. The solid head, 14, of the clothes container, 13, is fixed to the upper end of one of the end members at the rear of the machine, preferably by means of a spacing block 16 and the front or open end thereof has a block 17 arranged between the lower side of the receptacle and the side bars, 8 and 9, said block being designed to elevate the cylindrical receptacle at this end to permit the water compressed from the clothes to run downwardly toward the rear of the cylinder. This cylinder as shown is mounted in horizontal position and is provided at its top portion with a hinged door or closure 18 through which the clothes are inserted into and removed from the cylinder. A piston or compressing member 19 is disposed within the cylinder 13 and is made of a diameter slightly less than that of the cylinder to permit it to move freely therein. A screw threaded shaft, 20, is revolvably connected at the inner end with the outer face of the piston and extends through the open annular ring-shaped member at the front end thereof and through a block, 21, mounted at the upper end of the end member 3. This shaft, 20, is screw threaded throughout the length thereof and is sufficiently long to project beyond the block, 21, when the piston is at its extreme limit of its compression stroke. A block-like member, 22, is loosely mounted on the screw-shaft, 20, and brace arms, as 23, connect this block with the outer face of the piston, 19, and two nuts, 24 and 25, are secured on said shaft at opposite ends of said block, 22, and are preferably provided with washers, 26 and 27, arranged between them and the faces of said block, said nuts turning with the shaft 20 and bearing against the washers which prevent wear of the block 22. A bar, 28, is fastened at one end to said block, 22, and extends through the ring-shaped member at the end of the cylinder and is arranged between guides 29 and 30 mounted on the end member 3 and this bar projects some distance beyond said end member and is inclined upwardly to space the free end thereof a suitable distance above

the shaft 20 to support a bracket, 31, in which a sprocket (32) wheel is revolubly mounted. A similar sprocket wheel 33 is fixed to the outer end of the shaft 20 and a sprocket chain 34 connects the wheels 32 and 33 for a purpose to be described. The sprocket wheel, 32, is connected with any suitable source of power, being driven either by means of a crank handle 35, or it may be connected with an engine and driven mechanically.

The drain water vessel, 10, is preferably provided at the bottom thereof with an opening provided with a hinged closure, 10', said closure being opened when desired for letting off the water in said receptacle.

In the use of this improved clothes wringer the sprocket wheel, 32, is turned by any suitable means in one direction to cause the rotation of the shaft 20 and cause it to move longitudinally in the block 21 drawing with it the piston, 19. The clothes are then placed within the receptacle between the smooth inner face of the piston, 19, and the closed head of the cylinder. The sprocket wheels are then turned in the opposite direction to move the shaft inward and cause the piston 19 to compress the clothes and force the water out therefrom, and the water so forced out passes through the perforations in the cylinder into the drain receptacle arranged therebelow, from which it may be removed by buckets or any suitable means to a place of deposit.

From the fore-going description taken in connection with the accompanying drawings, the construction and operation of the invention will be readily understood without requiring a more extended explanation.

Various changes in the form, proportion and the minor details of construction may be resorted to without departing from the principle or sacrificing any of the advantages of this invention as defined in the appended claims.

I claim as my invention:—

1. In a clothes wringer the combination of a supporting structure, a perforated clothes receptacle or casing mounted in said structure and having one end thereof closed; a compressing member arranged within said receptacle, a screw threaded shaft revolubly connected at one end with said compressing member and extending

through and having screw-threaded engagement with said supporting structure, a member loosely mounted on said shaft intermediately of its ends, braces connecting said loosely mounted member with said compressing member, a bar secured at one end to said loosely mounted member and projecting through the end of the casing through which the shaft projects, the free end of said bar being connected with the free end of said shaft at the other end, a revolubly mounted sprocket wheel supported on the free end of the bar, a sprocket wheel fixed to the free end of said shaft, a sprocket chain connecting said wheels, and means for rotating said first mentioned sprocket wheel for imparting motion to the shaft in either direction.

2. In a clothes wringer, the combination of a supporting structure, a perforated clothes receptacle or casing thereof mounted in said structure and having one end thereof closed, a piston mounted within said casing and of a diameter slightly less than the diameter of the casing, a screw threaded shaft rotatably connected at one end with said piston and projecting through one end of the casing and having screw threaded engagement with said supporting structure, a block mounted on said shaft intermediately of its ends, braces connecting said block with said piston, nuts secured on said shaft on opposite sides of said block, a bar secured at one end to said block and projecting through the end of the casing through which the shaft projects, said bar being inclined upwardly and the free end thereof connected with the free end of said shaft by bracket arms, a revolubly mounted sprocket wheel supported by the free end of said bar, a sprocket wheel fixed to the free end of said shaft, a sprocket chain connecting said wheels and means for rotating said first-mentioned sprocket wheel for imparting motion to the shaft to move it in either direction.

In testimony whereof I have hereunto set my hand in presence of two subscribing witnesses.

SYLVESTER VARNEY.

Witnesses:

G. G. HERM,
GEO. J. THRAUTWEIT.