

July 16, 1968

K. W. TANTLINGER

3,392,857

SEPARABLE WHEELED UNITS FOR VEHICLIZING CONTAINERS

Original Filed July 25, 1963

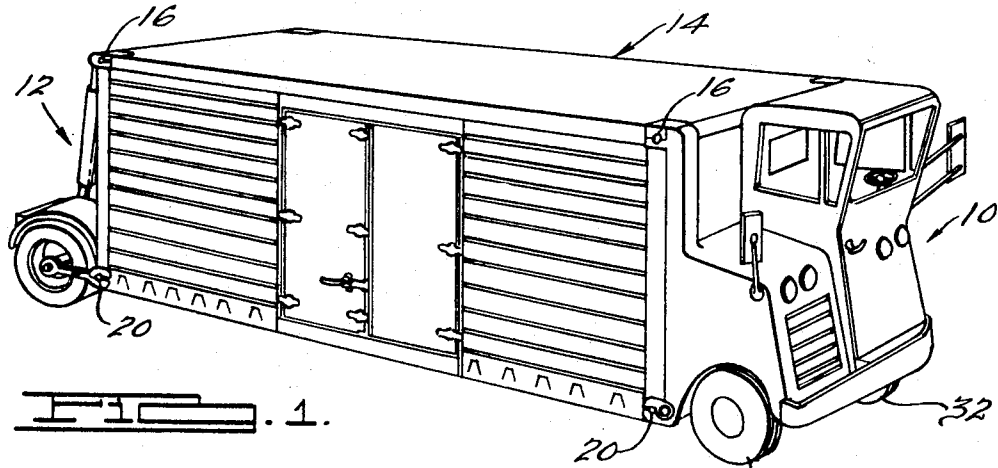

FIG. 1.

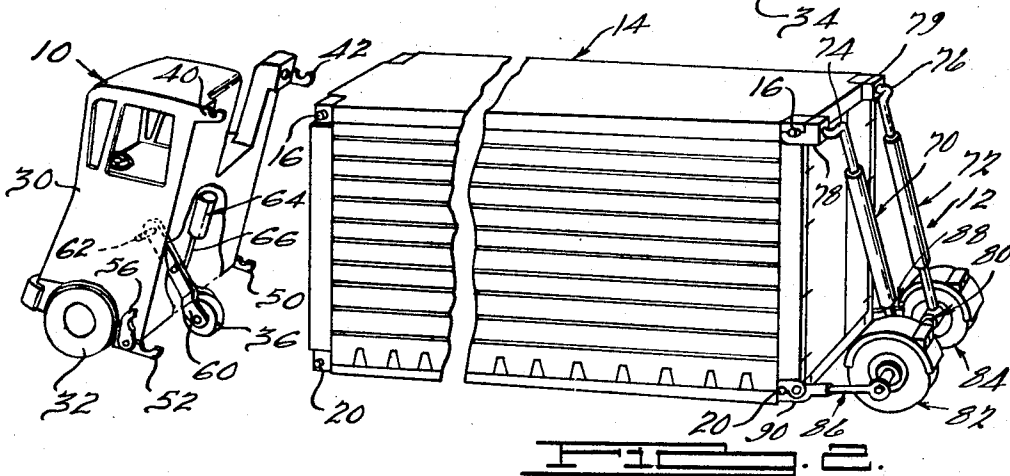

FIG. 2.

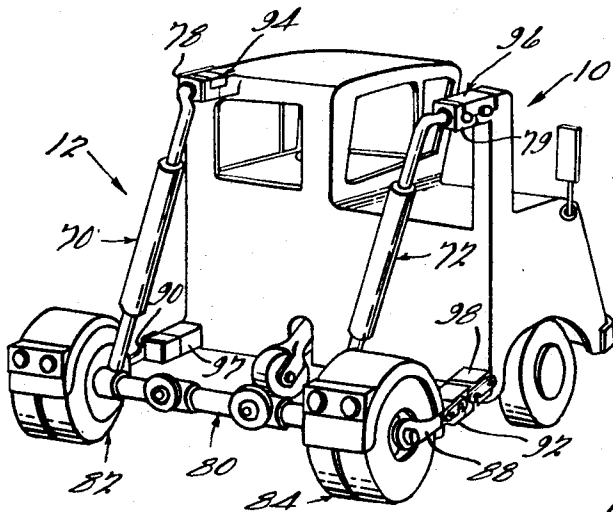

FIG. 3.

INVENTOR.

Keith W. Tantlinger.

BY

Harves, Dickey, Pence  
ATTORNEYS.

1

2

3,392,857

**SEPARABLE WHEELED UNITS FOR  
VEHICLIZING CONTAINERS**

Keith W. Tantlinger, Grosse Pointe Shores, Mich.,  
assignor to Fruehauf Corporation, a corporation  
of Michigan

Original application July 25, 1963, Ser. No. 297,605, now  
Patent No. 3,253,668. Divided and this application  
May 31, 1966, Ser. No. 569,778

1 Claim. (Cl. 214—390)

**ABSTRACT OF THE DISCLOSURE**

The disclosure relates to a wheeled unit that is engageable with a shipping container or another wheeled unit to mobilize the container or combined unit.

This application is a division of Ser. No. 297,605, filed July 25, 1963, now Patent 3,253,668.

This invention relates generally to shipping apparatus, and more particularly to a means for vehiclizing shipping containers to facilitate movement thereof about a dock facility or the like.

The modern modular shipping container has revolutionized the transfer of goods and materials in that such shipping containers materially expedite the loading of ships, trains, aircraft and the like in addition to being relatively easily adapted for highway travel. However, because such containers are generally quite large, a need has developed for an improved means for moving such container about a shipping facility.

The separable wheeled units of the instant invention offer a unique solution to this problem. The wheeled units are relatively easily attached to a shipping container to facilitate movement thereof, thence easily detachable therefrom.

A separable wheeled vehiclizing means, in accordance with an exemplary embodiment of the instant invention, comprises what is essentially a two-armed apparatus that grips the top and bottom of a shipping container. A wheel is provided at the juncture of the two arms. After attachment to the shipping container one of the arms is elongated to vary the angular relationship of the arms to the vertical side wall of the shipping container thereby effecting elevation of the shipping container and transfer of the load of the container to the wheel on the vehiclizing apparatus.

Accordingly, one object of the instant invention is an improved means for vehiclizing a shipping container.

Another object is a wheeled unit that is relatively easily attached to and detached from a shipping container to facilitate movement thereof.

Another object is a wheeled unit having a minimum number of moving parts for attachment to a shipping container.

Other objects and advantages of the instant invention will be apparent from the following description, claim and drawings, wherein:

FIGURE 1 is a perspective view of a pair of wheeled units, one of which is motorized, shown in operative association with a conventional shipping container;

FIG. 2 is a view similar to FIG. 1 showing the motorized unit detached from the shipping container;

FIG. 3 is a perspective view of the front and rear wheeled units coupled to one another to facilitate movement thereof independently of the shipping container.

Referring now to FIGURE 1 of the drawings, a pair of wheeled units 10 and 12 are shown in operative association with a conventional shipping container 14. The shipping container 14 is provided with a plurality of horizon-

tally extending pins 16 at each of the upper corners thereof and a like plurality of pins 20 at each of the lower corners thereof to facilitate coupling of the front and rear wheeled units 10 and 12 to the container 14.

As best seen in FIGURE 2 of the drawings, the wheeled unit 10 comprises a cab 30 having a pair of spaced axially aligned wheels 32 and 34 with an intermediate wheel 36 spaced rearwardly from the axis thereof. The wheeled unit 10 is provided with a pair of spaced upper pin couplers 40 and 42 at the upper extremity thereof for engagement with the pins 16 on the container 14. It should be apparent that when the unit 10 is in the condition shown in FIGURE 2, namely, canted rearwardly, the couplers 40 and 42 are relatively lower than when the wheeled unit 10 is in the condition shown in FIGURE 1 thereby facilitating engagement of the couplers 40 and 42 under the pins 16.

The wheeled unit 10 is provided with a pair of rigid lower couplers 50 and 52 that are engageable with the lower pins 20 and on the container 14. A pair of pivotable jaws 54 and 56 are provided on the couplers 50 and 52, respectively, to preclude inadvertent miscoupling of the wheeled unit 10 from the container 14.

The intermediate wheel 36 of the wheeled unit 10 is supported on a downwardly depending arm 60 that is pivotally supported within the wheeled unit 10 as by a pin 62. The rotative position of the arm 60 is controlled by a hydraulic actuator 64, a piston 66 of which is connected to the arm 60. Appropriate energization of the hydraulic cylinder 64 effects clockwise movement of the arm 60 about the pin 62, as seen in FIGURE 2 of the drawings, thereby to vary the angular relationship between a plane containing the axis of the wheels 32, 34 and the pin 62, and a plane containing the wheel 36 and pin 62 thereby to effect elevation of the couplers 40, 42, 50 and 52. It should be noted that the couplers 40 and 42 are engaged with the pins 16 on the container 14 prior to engagement of the couplers 50 and 52 with the pins 20. Energization of the hydraulic actuator 64 effects movement of the wheel unit to the vertical position. As the wheeled unit 10 moves to the vertical position the couplers 50 and 52 are interposed under the pins 20 on the container 14.

As best seen in FIGS. 2 and 3 of the drawings the wheeled unit 12 comprises a pair of generally vertically extending arms defined by extensible hydraulic actuators 70 and 72 having pistons 74 and 76 at the upper ends thereof, respectively. The pistons 74 and 76 are provided with upper couplers 78 and 79 that are engageable under the upper pins 16 on the container 14 to effect elevation thereof, as will be described.

The hydraulic actuators 70 and 72 are pivotally coupled to a transverse axle 80 upon which a pair of road contacting wheels 82 and 84 are journaled. A pair of generally horizontally extending arms 86 and 88 are pivotally coupled to the axle 80 and have suitable lower couplers 90 and 92 attached thereto for engagement with the lower pins 20 of the container 14. Energization of the actuators 70 and 72 effects elongation of the vertically extending arm defined thereby varying the angular relationships of the arms to the container 14 to effect elevation of the container 14.

As best seen in FIGURE 3 of the drawings suitable dummy pin blocks 94 and 96 are provided to effect coupling of the upper couplers 40 and 42 on the unit 10 with the upper couplers 78 and 79 on the wheel unit 12. Similarly, lower dummy pin blocks 97 and 98 are provided to facilitate coupling of the lower couplers 50 and 52 on the unit 10 with the lower couplers 90 and 92 on the wheel unit 12. When the units 10 and 12 are thus

3

coupled they are movable as a self-powered unit about, for example, a dock facility.

As best seen in FIGURES 4 through 7 of the drawings, a modified embodiment of the instant invention comprises a two-armed wheeled unit **100** having a generally vertically extending extensible arm **102** and a generally horizontal arm **104** of fixed length. The arm **102** is extended by, for example, movement of a gear rack **105** relative to a gear **108**. Rotation of the gear is effected through a complementary drive shaft **110** as by a conventional crank (not shown).

The extensible arm **102** is pivotally connected to the arm **104** as by a pin **120**. The arm **104** has a ground-contacting wheel **122** thereon and a fixed jaw **124**. The jaw **124** is engageable with a complementary pin **126** on a shipping container **130**, a pivotable upper jaw **132** being provided for locking purposes.

The arm **102** has a bracket **134** pivotally connected to the upper end thereof that is engageable with an upper pin **136** on a container **130**.

As best seen by comparing FIGURES 6 and 7 of the drawings, elevation of the container **130** is effected by elongation of the arm **102** of the unit **100** thereby effecting rotation of the horizontal arm **104** about the pin **126** on the container **130**. Similarly, the arm **102** rotates relative to the pin **136** engaged by the coupler at the upper end thereof. It is to be noted that, when in the vehiclizing condition, the wheeled unit **100** utilizes the container **130** as one leg of a triangle.

As best seen in FIGURE 5, a plurality of wheeled units **100** can be coupled to containers **130** and the containers **130** coupled to one another as by tow bars **140** and **142** thereby to facilitate movement of the containers **130** in a train about a dock or loading facility.

As best seen in FIGURES 8, 9, and 10 of the drawings, yet another embodiment of the instant invention comprises a wheeled unit **200** having an upwardly extending arm **202** and a generally horizontally extending arm **204** that are rigidly coupled to one another. A ground-contacting wheel **126** is disposed at the juncture of the arm portions **202** and **204**. In air bag **210** is disposed at an upper end portion **212** of the arm **202** for engagement with one wall **214** of a container **215**.

The lower arm **204** of the unit **200** has a container coupler **216** thereon for engagement under a complementary pin **218** on the container **215**. An upper coupler jaw **220** is provided for locking purposes.

As best seen by comparing FIGURES 9 and 10, the coupler **216** of the wheeled unit **200** is engageable with the container **130** with the air bag **210** in the deflated condition. Inflation of the air bag **210** effects rotation of the arms **202** and **204** counterclockwise about the ground-contacting wheel **206** thereby effecting elevation of the containers **215** and conditioning the container **215** for movement about a dock or loading facility.

From the foregoing description it should be apparent that the separable wheeled units of the instant invention are particularly well suited for vehiclizing a shipping container for movement about, for example, a dock facility. It is to be noted that each of the disclosed wheeled units utilizes the end wall of the shipping container as one leg of a triangle the sides of which vary in their angular relationship to one another to effect elevation of the container relative to a ground-contacting wheel.

4

The angular relationship of the sides of the triangle defined by the generally vertically and horizontally extending arms of wheeled units in conjunction with the end wall of the container may be varied by either lengthening of one of the arms or by rotating the arms relative to the end wall of the container.

Engagement of the wheeled units with the shipping container is easily accomplished by couplers on the units that are positionable under complementary pins on the containers. Elevation of the couplers on the wheeled units incident to changing in the angular relationship of the arms thereof to the end wall of the container effects both engagement of the couplers with the pins on the containers and elevation of the containers.

It is to be understood that the specific construction of the improved wheeled units for vehiclizing a container herein disclosed and described is presented for the purpose of explanation and illustration and is not intended to indicate limits of the invention, the scope of which is defined by the following claim.

I claim:

1. A pair of wheeled units for vehiclizing a shipping container having generally planar vertically extending end walls with coupling means at the top and bottom corners thereof, respectively, each of said wheeled units comprising, wheel and axle means, first extensible arms extending generally vertically and having means at the upper end thereof for releasably and pivotally engaging the coupling means at the top of the shipping container and means pivotally engaging the axle means laterally inwardly of said wheel means at the lower end, second non-extensible arms extending generally horizontally and having one end pivotally secured to said axle means laterally outwardly of said wheel means and having means at the other end thereof for releasably and pivotally engaging the coupling means at the bottom of the shipping container, the arms of said wheeled unit defining a triangle in conjunction with the end wall of the shipping container, said first arm being extensible to vary the angular relationship of said second arm to the end wall of the container thereby to vary the vertical position of the shipping container, said engaging means on said first and second arms being oriented in vertical alignment when said first and second arms are in said vertical and horizontal positions, respectively, and means for coupling the upper ends of said first arms and said other ends of said second arms on one of said wheeled units to the upper ends of said first arms and said other ends of said second arms on the other of said units, respectively, to form a separate wheeled unit independent of the shipping container.

#### References Cited

##### UNITED STATES PATENTS

2,968,490	1/1961	Baus	214—390 X
3,156,484	11/1964	Talbert	214—390 X
3,193,301	7/1965	Talbert et al.	214—390 X
3,243,193	3/1966	Fulmer et al.	214—390 X

GERALD M. FORLENZA, *Primary Examiner*.

ALBERT J. MAKAY, *Assistant Examiner*.