



INTERNATIONAL APPLICATION PUBLISHED UNDER THE PATENT COOPERATION TREATY (PCT)

<p>(51) International Patent Classification ⁴ : H04S 1/00, H03G 5/02</p>	<p>A1</p>	<p>(11) International Publication Number: WO 87/ 06090 (43) International Publication Date: 8 October 1987 (08.10.87)</p>
<p>(21) International Application Number: PCT/US87/00099 (22) International Filing Date: 27 January 1987 (27.01.87) (31) Priority Application Numbers: 844,929 929,452 (32) Priority Dates: 27 March 1986 (27.03.86) 12 November 1986 (12.11.86) (33) Priority Country: US (71) Applicant: HUGHES AIRCRAFT COMPANY [US/US]; 7200 Hughes Terrace, Los Angeles, CA 90045-0066 (US). (72) Inventor: KLAYMAN, Arnold, I. ; 16821 Phelps Lane, Huntington Beach, CA 92649 (US). (74) Agents: SZABO, Joseph, E. et al.; Hughes Aircraft Company, Building C1, M/S A126, Post Office Box 45066, Los Angeles, CA 90045-0066 (US).</p>		<p>(81) Designated States: AU, CH (European patent), DE (European patent), FR (European patent), GB (European patent), JP, KR, NL (European patent), SE (European patent). Published With international search report.</p>

(54) Title: STEREO ENHANCEMENT SYSTEM

(57) Abstract

A stereo enhancement system (300) which provides an enhanced wider stereo image and a wider listening area, and further provides perspective correction for achieving correct stereo sound perspective with speakers at different locations and with headphones. The stereo enhancement system includes a stereo image enhancement system (100, 10, 110) which includes circuitry (11, 13, 111, 113) for generating sum and difference signals based on left and right stereo signals, circuitry (17, 18, 19, 22, 30,

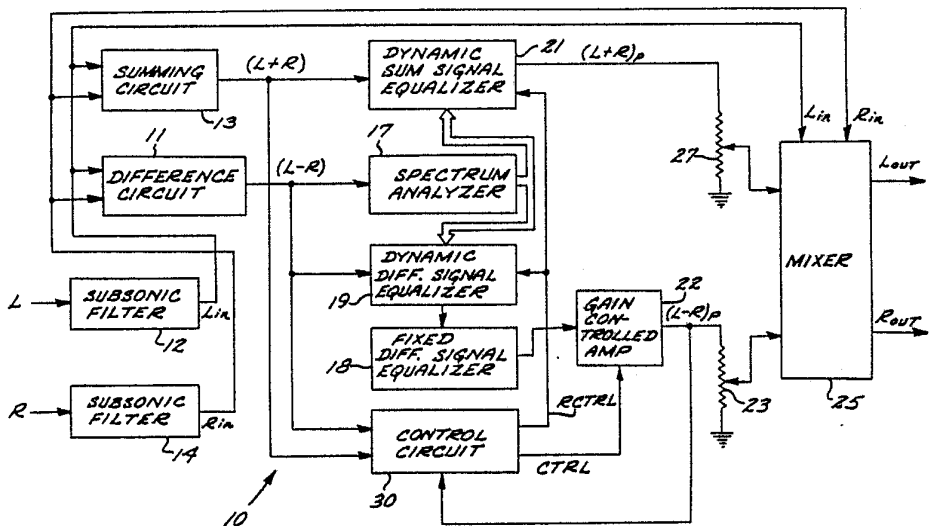

115, 125, 129, 40) for selectively altering the relative amplitudes of the difference signal components, circuitry (17, 21, 30, 117, 127, 40) for selectively altering the relative amplitudes of the sum signal components, and circuitry (23, 25, 27, 119, 121, 123) for combining the processed sum and difference signals with the original left and right stereo signals to produce enhanced left and right stereo signals. The enhancement system further includes a perspective correction system (200, 210) which is responsive to the enhanced left and right signals provided by the stereo image enhancement system or to left and right stereo signals of an audio system. The perspective correction system includes circuitry (211, 213) for generating sum and difference signals from the left and right stereo signals, equalization circuitry (215, 217, 221, 223) for providing fixed equalization for the sum and difference signals to compensate for the variation with direction of the frequency response of the human ear, and mixing circuitry (225) for combining the equalized sum and difference signals to produce left and right signals.

FOR THE PURPOSES OF INFORMATION ONLY

Codes used to identify States party to the PCT on the front pages of pamphlets publishing international applications under the PCT.

AT	Austria	FR	France	ML	Mali
AU	Australia	GA	Gabon	MR	Mauritania
BB	Barbados	GB	United Kingdom	MW	Malawi
BE	Belgium	HU	Hungary	NL	Netherlands
BG	Bulgaria	IT	Italy	NO	Norway
BJ	Benin	JP	Japan	RO	Romania
BR	Brazil	KP	Democratic People's Republic of Korea	SD	Sudan
CF	Central African Republic	KR	Republic of Korea	SE	Sweden
CG	Congo	LI	Liechtenstein	SN	Senegal
CH	Switzerland	LK	Sri Lanka	SU	Soviet Union
CM	Cameroon	LU	Luxembourg	TD	Chad
DE	Germany, Federal Republic of	MC	Monaco	TG	Togo
DK	Denmark	MG	Madagascar	US	United States of America
FI	Finland				

STEREO ENHANCEMENT SYSTEM

1 This application is a continuation-in-part of my application for STEREO
ENHANCEMENT SYSTEM filed March 27, 1986, Serial No. 844,929.

BACKGROUND OF THE INVENTION

5 The disclosed invention generally relates to an enhancement system for
stereo sound reproduction systems, and is particularly directed to a stereo
enhancement system which broadens the stereo sound image, provides for an
increased stereo listening area, and provides for perspective correction for
the use of speakers or headphones.

10 As is well known, a stereo sound reproduction system attempts to
produce a sound image wherein the reproduced sounds are perceived as
emanating from different locations, thereby simulating the experience of a
live performance. The aural illusion of a stereo sound image is generally
perceived as being between the speakers, and the width of the stereo image
depends to a large extent on the similarity or dissimilarity between the
15 information respectively provided to the left and right speakers. If the
information provided to each speaker is the same, then the sound image will
be centered between the speakers at "center stage." In contrast, if the
information provided to each speaker is different, then the extent of the
sound image will spread between the two speakers.

20 While the general concept of stereo sound imaging is not complex, its
use and implementation is more difficult. The width of the stereo sound
image depends not only on the information provided to the speakers, but also
on listener position. Ideally, the listener is equidistant from the speakers.
With many speaker systems, as the listener gets closer to one speaker, the
25 sound from the more distant speaker contributes less to the stereo image, and
the sound is quickly perceived as emanating only from the closer speaker.

1 This is particularly so when the information in each speaker is not very
different. However, even with the listener equidistant from the speakers, the
perceived sound image is generally between the physical locations of the
speakers and does not extend beyond the region between the speakers.

5 Some known speaker systems have been designed to reduce the limita-
tion that a listener should ideally be located equidistant between speakers.
However, such speaker systems are generally complex and the resulting
stereo image is still limited to the region between the physical locations of
the speakers.

10 Another consideration in stereo sound reproduction is the fact that the
sound transducers (typically speakers or headphones) are located at predeter-
mined locations, and therefore provide sound emanating from such predeter-
mined locations. However, in a live performance, the perceived sound may
emanate from many directions as a result of the acoustics of the structure
15 where the performance takes place. The human ears and brain cooperate to
determine direction on the basis of different phenomena, including relative
phase shift for low frequency sounds, relative intensity for sounds in the
voice range, and relative time arrival for sounds having fast rise times and
high frequency components.

20 As a result of the predetermined locations of speakers or headphones, a
listener receives erroneous cues as to the directions from which the repro-
duced sounds are emanating. For example, for speakers located in front of
the listener, sounds that should be heard from the side are heard from the
front and therefore are not readily perceived as being sounds emanating from
25 the sides. For headphones or side mounted speakers, sounds that should
emanate from the front emanate from the sides. Thus, as a result of the
placement of speakers or headphones, the sound perspective of a recorded
performance is incorrect.

30 There have been numerous attempts to spread and widen the stereo
image with mixed results. For example, it is known that the left and right
stereo signals may be mixed to provide a difference signal (such as left minus
right) and a sum signal (left plus right) which can be selectively processed and
then mixed to provide processed left and right signals. Particularly, it is well
known that increasing or boosting the difference signal produces a wider
35 stereo image.

1 Another advantage would be to provide a stereo enhancement system which provides for a stereo sound image that may be perceived over a large listening area.

5 Still another advantage would be to provide a stereo correction system which provides for sound perspective correction for use with speakers or headphones.

10 The foregoing and other features and advantages are achieved by the stereo enhancement system of the invention which includes a stereo image enhancement system for providing a wider stereo image and listening area, and a perspective correction system which provides for sound perspective correction for use with speakers or headphones. The stereo image enhancement system and the perspective correction system may be utilized in combination or individually.

15 In accordance with the invention, a wider stereo sound image and listening area are achieved by generating sum and difference signals based on left and right stereo signals, selectively altering the relative amplitudes of the difference signal frequencies and the relative amplitudes of the sum signal frequencies, and combining the processed sum and difference signals with the original left and right signals to produce enhanced left and right stereo signals.

20 Particularly, selected frequency components of the difference signal are boosted (emphasized) relative to other difference signal frequency components, and selected frequency components of the sum signal are boosted relative to other sum signal frequency components. The selective boosting of the difference signal provides for a wider stereo image and a wider listening area, and the selective boosting of the sum signal prevents the sum signal from being overwhelmed by the difference signal.

25 In one embodiment of the invention, a spectrum analyzer that is responsive to the difference signal controls the relative amplitudes of the difference signal frequency components so that the quieter difference signal frequency components are boosted relative to louder difference signal frequency components. The difference signal is also equalized by a fixed equalizer so that the difference signal frequencies having wavelengths comparable to the distance between a listener's ears are deemphasized. The spectrum analyzer further controls the relative amplitudes of the sum signal frequency components so that sum signal frequency components are boosted

30

35

1 in proportion to the levels of corresponding difference signal frequency
components.

In another embodiment of the invention, the difference signal is
equalized with a fixed difference signal equalizer so that difference signal
5 frequency components that statistically include quieter difference com-
ponents are boosted relative to difference signal frequency components that
statistically include louder difference signal frequencies. The sum signal is
equalized with a fixed sum signal equalizer so that the sum signal in the
frequency range that statistically includes difference signal frequency com-
10 ponents are boosted.

As a result of the selective emphasis or boost of the difference signal
components, a wider stereo image is provided, and the harshness and image
shifting problems associated with indiscriminate increase of the difference
signal are substantially reduced by the equalization provided by the fixed
15 equalizer utilized by the invention. The selective emphasis or boost of the
quieter difference signal components further enhances the stereo image for
the following reasons. Ambient reflections and reverberant fields at a live
performance are readily perceived and are not masked by the direct sounds.
In a recorded performance, however, the ambient sounds are masked by the
20 direct sounds, and are not perceived at the same level as at a live
performance. The ambient sounds generally tend to be in the quieter
frequencies of the difference signal, and boosting the quieter frequencies of
the difference signal unmask the ambient sounds, thereby simulating the
perception of ambient sounds at a live performance.

25 The selective emphasis of the difference signal also provides for a
wider listening area for the following reasons. The louder frequency
components of the difference signal tend to be in the mid-range which
includes frequencies having wavelengths comparable to the ear-to-ear dis-
tance around the head of a listener (the previously mentioned "difference
30 signal frequency components of increased phase sensitivity"). As a result of
the selective emphasis provided by the invention, the difference signal
frequency components of increased phase sensitivity are not inappropriately
boosted. Therefore, the stereo image shifting problem resulting from
indiscriminate increase of the difference signal (discussed above in the
35 background) is substantially reduced, and the listener is not limited to being
equidistant from the speakers.

1 In providing the selective boosting of the difference signal, the amount
of enhancement, which is determined by the level of the selectively boosted
difference signal that is mixed, is automatically adjusted so that the amount
of stereo provided is relatively consistent. Without such automatic adjust-
5 ment, the amount of enhancement provided would have to be manually
adjusted for the differing amounts of stereo in different recordings.

 The process of selectively boosting the difference signal also boosts any
artificial reverberation introduced in the recording process since artificial
reverberation is predominantly in the difference signal. In order to avoid the
10 inappropriate boosting of artificial reverberation, the enhancement system of
the invention monitors the sum and difference signals for characteristics that
indicate the possible presence of artificial reverberation. If the possibility of
artificial reverberation is detected, the amount of boost provided for the
difference signal is selectively reduced and the amount of boost for the sum
15 signal is selectively increased.

 A further aspect of the disclosed invention is a sound perspective
correction system which provides perspective correction for recorded perfor-
mances reproduced with speakers located at different positions or with
headphones. The perspective correction system selectively modifies sum and
20 difference signals derived from the left and right stereo signals to that the
reproduced sounds are perceived as emanating from the directions a listener
would expect at a live performance. Thus, with speakers located in front of
the listener, sounds that should be heard as emanating from the sides are
perceived as emanating from the sides. With headphones, sound that should
25 be heard as emanating from the front are perceived as emanating from the
front.

 The sound perspective correction system achieves perspective correc-
tion by generating sum and difference signals from left and right stereo
signals, providing fixed equalization for the sum and difference signals to
30 compensate for the variation with direction of the frequency response of the
human ear, and combining the equalized sum and difference signals to
produce left and right signals. For speakers located in front of the listener,
the difference signal is selectively boosted so that side sounds are restored to
the appropriate levels that would have been perceived had they been
35 reproduced to emanate from the sides. For speakers located to the side or
for headphones, the sum signal is selectively attenuated to restore front

1 sounds to the appropriate levels that would have been perceived had they
been reproduced to emanate from the front.

As indicated previously, the sound perspective correction system of the
invention may be utilized in conjunction with the above-summarized stereo
5 image enhancement system of the invention or may be utilized alone with
other audio components.

Principles of the present invention are applicable both for playback of
conventional stereo phonograph records, magnetic tapes and digital discs
through a conventional sound reproducing system including a pair of loud-
10 speakers and for making unique recordings on phonograph records, digital
discs or magnetic tape which recordings can be played on a conventional sound
reproducing system to produce left and right stereo output signals providing
the advantageous effects described above.

15 BRIEF DESCRIPTION OF THE DRAWINGS

The advantages and features of the disclosed invention will readily be
appreciated by persons skilled in the art from the following detailed
description when read in conjunction with the drawing wherein:

FIG. 1 is a block diagram of the stereo enhancement system of the
20 invention.

FIG. 2 is a block diagram of a dynamic stereo image enhancement
system in accordance with the invention which provides for dynamic equali-
zation.

FIG. 3 is a block diagram of the feedback and reverberation control
25 circuit for the stereo image enhancement systems of FIGS. 2 and 4.

FIG. 4 is a block diagram of a non-dynamic or fixed stereo image
enhancement system in accordance with the invention which provides for
fixed equalization.

FIGS. 5A and 5B are plots of the equalization provided by the fixed
30 stereo image enhancement system of FIG. 4.

FIG. 6 is a block diagram of a sound perspective correction system in
accordance with the invention.

FIGS. 7A and 7B are frequency responses of the human ear which are
helpful in understanding stereo image enhancement systems of FIGS. 2 and 4
35 and the sound perspective correction system of FIG. 5.

1 FIG. 7C is the frequency response of FIG. 7A relative to FIG. 7B.
 FIG. 7D is the frequency response of FIG. 7B relative to FIG. 7A.
 FIGS. 8 and 9 illustrate sound reproducing and sound recording systems
 respectively, each of which employs either or both of the stereo image
5 enhancement and perspective correction arrangements embodying principles
 of the present invention.
 FIG. 10 is a block diagram of the stereo enhancement system having
 automatic and manual control of reverberation enhancement.
 FIG. 11 shows an alternative attenuating reverberation filter.

10

DETAILED DESCRIPTION OF THE DISCLOSURE

In the following detailed description and in the several figures of the drawing, like elements are identified with like reference numerals.

15 In order to facilitate the understanding of the invention, the following
 discussion is provided in different sections, with each subsequent section
 being more detailed than the previous section. Thus, an overview is first
 presented wherein the overall functions provided are discussed. Then, the
 invention is discussed in more detail with more emphasis on operating
 parameters.

20 I. OVERVIEW

 Referring now to FIG. 1, shown therein is a block diagram of the stereo
 enhancement system 300 of the invention, which includes a stereo image
 enhancement system 100 and a perspective correction system 200. The
 stereo image enhancement system 100 receives left and right stereo signals L
25 and R and processes such signals to provide image enhanced left and right
 stereo signals L' and R' to the perspective correction system 200. The
 perspective correction system 200 processes the image enhanced stereo
 signals to provide image enhanced stereo signals which have been corrected
 to provide for proper sound perspective when amplified and played through
30 speakers or headphones.

 For use with standard commercially available audio components, the
 stereo enhancement system 300 of the invention may be utilized in the tape
 monitor loop or, if available, in an external processor loop of a preamplifier.
 Such loops are not affected by the preamplifier controls such as tone
35 controls, balance control, and volume control. Alternatively, the stereo
 enhancement system 300 may be interposed between the preamplifier and

1 power amplifier of a standard stereo sound reproduction system. However,
with such installation, the balance and tone controls are preferably disabled
or nulled.

5 The disclosed stereo enhancement system 300 may be readily incorpor-
ated for production into audio preamplifiers that are manufactured and sold
as separate units, as well as into audio preamplifiers that are included in
integrated amplifiers and receivers. As so incorporated, the stereo enhance-
ment system 100 is preferably upstream of the tone and balance controls and
preferably is capable of being bypassed.

10 It should be noted that the enhancement provided by the disclosed
stereo enhancement system 300 can be advantageously utilized to enhance
recordings. Such recordings can be played back on an audio system which
does not include the stereo enhancement system 300, or an audio system
which does include the stereo enhancement system 300 and which has been
15 bypassed. Thus, for example, a recording which includes image enhancement
and perspective correction can be made for playback in an automobile with
side mounted speakers. It should be noted that perspective correction may
not be desired in making recordings unless the playback conditions are known,
e.g., that playback will be only through side mounted automobile speakers.

20 It should also be noted that the stereo image enhancement system 100
and/or the perspective correction 200 may be utilized independently in an
audio system. Thus, for example, the perspective correction system 200
alone may be incorporated into an automobile audio system for correcting the
improper sound perspective caused by side mounted speakers. Also, for cost
25 considerations, the stereo image enhancement system 100 alone may be
incorporated in an audio system for home use.

Referring to FIG. 2, shown therein is a block diagram of a stereo image
enhancement system 10 which may be utilized as the stereo image enhance-
ment system 100 in the stereo enhancement system 300 of FIG. 1, and which
30 provides for dynamic equalization of the sum and difference of left and right
stereo signals to achieve a wider stereo image and a wider listening area.
Particularly, subsonically filtered left and right stereo signals L and R at the
outputs of subsonic filters 12, 14 are provided to a difference circuit 11 and a
summing circuit 13 which respectively provide a difference signal (L-R) and a
35 sum signal (L+R). A dynamic difference signal equalizer 19, a fixed
difference signal equalizer 18, and a gain controlled amplifier 22 cooperate

1 to selectively alter or modify the relative amplitudes of the difference signal
frequency components (also referred to herein as "components" or "frequen-
cies") to provide a processed difference signal $(L-R)_p$. A dynamic sum signal
equalizer 21 selectively alters or modifies the relative amplitudes of the sum
5 signal frequency components (also referred to herein as "components" or
"frequencies" to provide a processed sum signal $(L+R)_p$.)

A spectrum analyzer 17, which is responsive to the difference signal
provided by the difference circuit 11, controls the dynamic difference signal
equalizer 19 so that the quieter components of the difference signal are
10 boosted relative to the louder components. More specifically, the dynamic
difference signal equalizer 19 is controlled to attenuate the louder difference
signal components more than the quieter difference signal components. The
subsequent amplification of the equalized difference signal provides for a
processed difference signal wherein the quieter components have been
15 boosted relative to the louder difference signal components.

The fixed difference signal equalizer 18 selectively attenuates the
equalized difference signal provided by the dynamic difference signal equali-
zer 19 to provide deemphasis in a predetermined manner.

The spectrum analyzer 17 also controls the sum signal equalizer so that
20 components of the sum signal are boosted as a direct function of the levels of
corresponding difference signal components. More specifically, the sum
signal equalizer 21 boosts the sum signal to provide a processed sum signal
wherein the sum signal components have been boosted in proportion to the
amplitudes of correspondening difference signal amplitudes.

25 A feedback and reverberation control circuit 30 controls the gain of the
gain controlled amplifier 22 so that the amount of stereo provided is
relatively consistent from recording to recording. The control circuit 30 also
controls the difference signal equalizer 19 and the sum signal equalizer 21 so
that difference signal components that may include artificial reverberation
30 are not inappropriately boosted when the possibility of artificial reverbera-
tion is detected. When the possibility of artificial reverberation is detected
by the control circuit 30, the reverberation control signal RCTRL controls
the dynamic difference signal equalizer 19 to provide further attenuation in
selected frequency bands where artificial reverberation statistically occurs,
35 and the dynamic sum signal equalizer 21 to provide further boost in such
selected frequency bands. In this manner, any artificial reverberation which

1 may be present in the difference signal is not inappropriately boosted in the
subsequent amplification of the difference signal. The further boost of the
sum signal ensures that the sum signal frequencies in the selected frequency
bands are of sufficient level to compensate any artificial reverberation which
5 may not have been sufficiently attenuated by the dynamic difference signal
equalizer 19 pursuant to the reverberation control signal RCTRL.

The control circuit 30 is responsive to the sum and difference signals
provided by the summing circuit 11 and the difference circuit 13, and also to
the processed difference signal provided by the gain controlled amplifier 22.

10 Referring now to FIG. 4, shown therein is a block diagram of a further
embodiment of a stereo image enhancement system 110 which may be
utilized as the stereo image enhancement system 100 in the stereo enhance-
ment system of FIG. 1, and which provides for respective fixed equalization
of the sum and difference of left and right stereo signals to achieve a wider
15 stereo image and a wider listening area. Particularly, subsonically filtered
left and right stereo signals L and R from subsonic filters 112, 114 are
provided to a difference circuit 111 and a sum circuit 113 which generate
respective difference and sum signals (L-R) and (L+R). A fixed difference
signal equalizer 115, a gain controlled amplifier 125, and a reverberation
20 filter 129 cooperate to selectively boost certain difference signal components
relative to other difference signal components. A fixed sum signal equalizer
117 and a gain controlled amplifier 127 cooperate to selectively boost certain
sum signal components relative to other sum signal components. Effectively,
the sum and difference signals are respectively spectrally shaped or equalized
25 in a fixed predetermined manner.

Particularly, the difference signal is equalized so that the frequencies
where the quieter difference signal components statistically occur more
frequently are boosted relative to the frequencies where the louder differ-
ence signal components statistically occur more frequently. The sum signal
30 is equalized so that frequencies where the difference signal components
statistically occur are boosted relative to other frequencies.

The stereo image enhancement system 110 further includes a feedback
and reverberation control circuit 40 which is substantially similar to the
control circuit 30 of FIGS. 2 and 3 and provides substantially similar
35 functions. Particularly, the control circuit 40 cooperates with the gain
controlled amplifier 125 so that substantially consistent stereo is provided for

1 differing amounts of stereo within a given recording and between different recordings.

5 The control circuit 40 further cooperates with the gain controlled amplifier 127 and the reverberation filter 129 to compensate the effects of artificial reverberation. When the possibility of artificial reverberation is detected, the gain controlled amplifier 127 boosts the sum signal, and the reverberation filter 129 attenuates the difference signal components that statistically include artificial reverberation relative to other difference signal components. In this manner, the difference signal components that
10 may include artificial reverberation are not inappropriately boosted. The further boost to the sum signal is to compensate for any artificial reverberation which may not have been sufficiently attenuated by the reverberation filter 129.

15 Referring now to FIG. 6, shown therein is a block diagram of a sound perspective correction system 210 which may be utilized as the sound perspective correction system 200 in the stereo enhancement system of FIG. 1. The perspective correction system 210 is responsive to left and right signals provided by the outputs of a stereo image enhancement system in accordance with the invention as discussed above relative to FIGS. 2 and 4.
20 Alternatively, as discussed with reference to the stereo enhancement system 300 of FIG. 1, the left and right signals may be provided by an appropriate audio preamplifier.

The sound perspective correction system 210 includes a summing circuit 211 and a difference circuit 213 for respectively providing sum and difference signals (L+R) and (L-R). The sum and difference signals are respectively
25 equalized by a fixed sum signal equalizer 215 and a fixed difference signal equalizer 221, which provide different equalization characteristics.

30 Particularly, the fixed sum signal equalizer 215 provides for one equalization output, and the fixed difference signal equalizer 221 provides for one equalization output. A pair of two position switches 217, 223 control whether equalized or non-equalized sum and difference signals are provided to a mixer 225. The selection of the signals provided to the mixer 225 is determined by the type of sound transducers (e.g., speakers or headphones) and/or the location of the sound transducers (e.g., front or side) used for
35 sound reproduction. The mixer 225 mixes the sum and difference signals to provide processed left and right output signals which are the outputs of the

1 sound perspective correction system 210. As discussed above relative to the
stereo enhancement system 300 of FIG. 1, the outputs of the sound
perspective system 210 may be provided to the preamplifier tape monitor
loop input or to a standard power amplifier.

5 II. DETAILED BLOCK DIAGRAM DISCUSSION

A. The Dynamic Stereo Image Enhancement System

Referring again to FIG. 2, the stereo image enhancement system 10 of
the invention includes a left input signal subsonic filter 12 and a right input
signal subsonic filter 14 which are responsive to left and right stereo signals
10 L and R provided by a stereo sound reproduction system (not shown). For
example, the left and right stereo signals L and R may be provided by a
preamplifier tape monitor loop output. The subsonic filters 12, 14 provide
subsonically filtered input signals L_{in} and R_{in} to a difference circuit 11 and a
summing circuit 13.

15 Each of the subsonic filters 12, 14 is a high pass filter having a -3 dB
frequency of 30 Hz and a roll-off of 24 dB per octave. The sharp roll-off
provides some protection against damage to speakers in the event a phono
cartridge is accidentally dropped. Vertical displacement of a stylus due to
dropping a phono cartridge is manifested as low frequency difference signal
20 components with large amplitudes, which could be potentially damaging to
speakers. The sharp subsonic filter roll-off cuts off such low frequency
components to reduce the possibility of damage.

The difference circuit 11 subtracts the right subsonically filtered signal
 R_{in} from the left subsonically filtered signal L_{in} to provide a difference
25 signal (L-R), while the summing circuit 13 adds the left and right subsonically
filtered input signals L_{in} and R_{in} to provide a sum signal (L+R).

The difference signal (L-R) is provided to a multi-band spectrum
analyzer 17. The difference signal (L-R) is further provided to a multi-band
dynamic difference signal equalizer 19 which is controlled by control signals
30 provided by the spectrum analyzer 17. The sum signal (L+R) is provided to a
multi-band dynamic sum signal equalizer 21 which is also controlled by the
control signals provided by the spectrum analyzer 17.

The multi-band spectrum analyzer 17 is responsive to predetermined
frequency bands and provides respective control signals associated with each
35 of the predetermined frequency bands. Particularly, such control signals are
proportional to respective average amplitudes of the difference signal (L-R)

1 within the respective predetermined frequency bands. By way of example,
the multi-band spectrum analyzer 17 includes a plurality of one octave wide
bandpass filters respectively centered in the predetermined frequency bands
and respectively having roll-offs of 6 dB per octave. The respective outputs
5 of the bandpass filters are rectified and appropriately buffered to provide the
control signals.

The dynamic difference signal equalizer 19 is also responsive to the
predetermined frequency bands and selectively cuts (attenuates) the differ-
ence signal frequencies in such predetermined frequency bands in response to
10 the control signals provided by the spectrum analyzer 17. Specifically, the
difference signal equalizer 19 attenuates the difference signal components
within the respective predetermined frequency bands as a direct function of
the respective control signals provided by the spectrum analyzer 17. That is,
for a given frequency band, attenuation increases as the average amplitude of
15 the difference signal (L-R) within such frequency band increases.

The output of the dynamic difference signal equalizer 19 is provided to
a fixed difference signal equalizer 18 which attenuates selected frequencies
of the dynamically equalized difference signal in a predetermined manner.
An appropriate equalization characteristic for the fixed difference signal
20 equalizer 18 is shown in FIG. 5A. By way of example, the fixed difference
signal equalizer 18 may include a plurality of parallel filter stages including a
low pass filter and a high pass filter having the following characteristics.
The low pass filter has a -3 dB frequency of about 200 Hz, a roll-off of 6 dB
per octave, and a gain of unity. The high pass filter has a -3 dB frequency of
25 about 7 KHz, a roll-off of 6 dB per octave, and a gain of one-half.

The fixed equalization of the fixed difference equalizer 18 is provided
(a) so that frequencies to which the ear has greater sensitivity (about 1 KHz
to about 4 KHz) are not inappropriately boosted, and (b) so that difference
signal components having wavelengths comparable to the distance between
30 the ears of a listener (the previously discussed "difference signal components
of increased phase sensitivity") are not inappropriately boosted. Alterna-
tively, such fixed equalization may be provided prior to dynamic equalization.

The difference signal provided by the fixed difference signal equalizer
18 is amplified by a gain controlled amplifier 22 to provide a processed
35 difference signal (L-R)_p.

1 The dynamic sum signal equalizer 21 is also responsive to the pre-
determined frequency bands and selectively boosts the sum signal frequencies
in such predetermined frequency bands in response to the control signals
provided by the spectrum analyzer 17. Specifically, the dynamic sum signal
5 equalizer 21 boosts the sum signal components within the respective prede-
termined frequency bands as a direct function of the respective control
signals provided by the spectrum analyzer 17. That is, for a given frequency
band, boost increases as the average amplitude of the difference signal (L-R)
within such frequency band increases. The output of the dynamic sum signal
10 equalizer 21 is a processed sum signal $(L+R)_p$.

 The predetermined frequency bands for the spectrum analyzer 17, the
dynamic difference signal equalizer 19, and the dynamic sum signal equalizer
21 include seven (7) bands of one octave width each which are respectively
centered at 125 Hz, 250 Hz, 500 Hz, 1 KHz, 2 KHz, 4 KHz, and 8 KHz. A
15 larger or smaller number of predetermined frequency bands may be readily
utilized.

 The dynamic difference signal equalizer 19 provides for each of the
frequency bands a maximum attenuation of 12 dB for the maximum level of
the corresponding control signals provided by the spectrum analyzer 17. No
20 attenuation would be provided for a control signal having a zero level.
Similarly, the dynamic sum signal equalizer 21 provides for each of the
frequency bands a maximum boost of 6 dB for the maximum level of the
corresponding control signals provided by the spectrum analyzer 17. No boost
would be provided for a control signal having a zero level.

25 The control signals provided by the spectrum analyzer 17 have a range
between 0 volts and 8 volts. The corresponding range of attenuation provided
by the dynamic difference signal equalizer 19 would be between 0 dB and -12
dB, while the corresponding range of boost provided by the sum signal
equalizer 21 would be between 0 dB and 6 dB.

30 It should be readily apparent that for a given control signal for a
particular frequency band, the value of the boost provided by the dynamic
sum signal equalizer 21 is one-half of the value of the attenuation provided
by the dynamic difference signal equalizer 19. Other ratios may be utilized,
but it is important that the level of boost provided by the dynamic sum signal
35 equalizer 21 be less than the corresponding level of attenuation provided by
the dynamic difference signal equalizer 19. Such reduced boost has been

1 found to be appropriate since most recordings include more sum signal than
difference signal. A maximum boost level approaching the maximum
attenuation level would result in inappropriately high levels of the processed
sum signal $(L+R)_p$.

5 As discussed further herein, selected frequency bands of the dynamic
difference signal equalizer 19 and the dynamic sum signal equalizer 21 are
further responsive to other control signals. The foregoing discussion of the
responses of such equalizers to the control signals provided by the spectrum
analyzer were based on such other control signals having zero levels. To the
10 extent that other control signals have non-zero levels, the total attenuation
or boost is the superposition of the individual attenuation or boost due to the
individual control signals. In other words, the respective control signals are
added.

It should be noted that preferably the dynamic difference signal
15 equalizer 19 is configured to provide for each of the frequency bands a
maximum attenuation, such as 12 dB, in order to avoid inappropriate levels of
attenuation. Similarly, the dynamic sum signal equalizer 21 is preferably
configured to provide for each of the frequency bands a maximum boost, such
as 6 dB, in order to avoid inappropriately high levels of boost.

20 The stereo image enhancement system 10 further includes a feedback
and reverberation control circuit 30 which cooperates with other elements in
the system to provide for automatic adjustment of the stereo image
enhancement provided and for reverberation compensation. The character-
istics of recordings that make automatic enhancement adjustment and
25 reverberation compensation desirable are discussed further below.

The control circuit 30 (described in more detail below relative to FIG.
3) is responsive to the difference signal $(L-R)$ provided by the difference
circuit 11 and the sum signal $(L+R)$ provided by the sum circuit 13. The
control circuit 30 provides a gain control signal CTRL for controlling the gain
30 controlled amplifier 22 which varies the gain applied to the difference signal
provided by the fixed difference signal equalizer 18. The control circuit 30 is
further responsive to the processed difference signal $(L-R)_p$ provided by the
gain controlled amplifier 22, thereby providing a closed loop system for
controlling the processed difference signal $(L-R)_p$.

35 The control circuit 30 controls the gain of the gain controlled amplifier
22 to maintain a constant ratio between (1) the sum signal $(L+R)$ provided by

1 the summing circuit 13 and (2) the processed difference signal $(L-R)_p$ output
of the gain controlled amplifier 22. By way of example, the gain controlled
amplifier 22 may be an appropriate voltage controlled amplifier.

5 The control circuit 30 further provides a reverberation control signal
RCTRL to the difference signal equalizer 19 and the sum signal equalizer 21
for controlling the amount of equalization provided in the frequency bands
centered at 500 Hz, 1 KHz, and 2 KHz (herein the "reverberation bands").
The presence of artificial reverberation, which is almost always in difference
10 signal frequencies in the reverberation bands, is indicated by a larger than
expected ratio between the sum signal and the difference signal, since a large
ratio indicates the presence of a center stage soloist (vocalist or instrumen-
talist), which in turn indicates the possibility of artificial reverberation. The
control circuit 30, therefore, monitors the ratio between the sum signal $(L+R)$
and the difference signal $(L-R)$. When the possible presence of artificial
15 reverberation is detected (for example, when the sum signal to difference
signal ratio is greater than a predetermined value), the reverberation control
signal RCTRL provides further control of the reverberation bands in the
difference signal equalizer 19 and the sum signal equalizer 21.

20 As to the difference signal equalizer 19, the reverberation control
signal RCTRL causes further attenuation in the above specified reverberation
bands in addition to the attenuation resulting from the control signals
provided by the spectrum analyzer 17. As to the sum signal equalizer 21, the
reverberation control signal RCTRL causes further boost in the above
specified reverberation bands in addition to the boost resulting from the
25 control signals provided by the spectrum analyzer 17.

The further attenuation of the difference signal components within the
reverberation bands is to prevent any artificial reverberation which may be
accompanying a soloist from being inappropriately boosted when the pro-
cessed difference signal is subsequently amplified. The further boost of the
30 sum signal components within the reverberation bands insures that the sum
signal components in the reverberation bands are of sufficient level to
compensate any artificial reverberation that is not sufficiently attenuated by
the dynamic difference signal equalizer 19.

35 The dynamic difference signal equalizer 19 provides for each of the
above specified reverberation bands a maximum attenuation of 12 dB for the
maximum level of the reverberation control signal RCTRL, with no corres-

1 ponding control signal from the spectrum analyzer 17 present. The total
attenuation provided in response to both the reverberation control signal
RCTRL and a corresponding control signal from the spectrum analyzer 17
would be the superposition of the respective attenuations in response to the
5 individual control signals. However, as noted previously, the dynamic
difference signal equalizer 19 is preferably configured to provide a predeter-
mined maximum attenuation, such as 12 dB, regardless of the levels of the
control signals.

The dynamic sum signal equalizer 21 provides for each of the above
10 specified reverberation bands a maximum boost of 6 dB for the maximum
level of the reverberation control signal RCTRL, with no corresponding
control signal from the spectrum analyzer 17 present. The total boost
provided in response to both the reverberation control signal RCTRL and a
corresponding control signal from the spectrum analyzer 17 would be the
15 superposition of the respective boosts in response to the individual control
signals. However, as noted previously, the dynamic sum signal equalizer 21 is
preferably configured to provide a predetermined maximum boost, such as 6
dB, regardless of the levels of the control signals.

Alternatively, reverberation compensation for the processed sum signal
20 may be achieved by utilizing a gain controlled amplifier (not shown) to vary
the gain applied to the equalized sum signal provided by the dynamic sum
signal equalizer 21. Such gain controlled amplifier would amplify the
processed sum signal as a function of the reverberation control signal
RCTRL. If a gain controlled amplifier to amplify the processed sum signal is
25 utilized to compensate the effects of artificial reverberation, the reverbera-
tion control signal RCTRL would not be provided to the dynamic sum signal
equalizer 21.

The output of the gain controlled amplifier 22 is coupled to one fixed
terminal of a potentiometer 23 which has its other fixed terminal coupled to
30 ground. The wiper contact of the potentiometer 23 is coupled to a mixer 25
which therefore receives the processed difference signal $(L-R)_p$ having a
level controlled by the gain controlled amplifier 22 and the potentiometer 23.

As mentioned previously, the control circuit 30 and the gain controlled
amplifier 22 control the ratio between the sum signal $(L+R)$ provided by the
35 summing circuit 13 and the processed difference signal $(L-R)_p$ provided by
the gain controlled amplifier 22. As discussed further herein, that ratio is

1 controlled by circuitry within the control circuit 30. The potentiometer 23 provides further control over the amount of stereo enhancement provided.

The output of the dynamic sum signal equalizer 21 is coupled to one fixed terminal of a potentiometer 27 which has its other fixed terminal
5 coupled to ground. The wiper contact of the potentiometer 27 is coupled to the mixer 25 which therefore receives the processed sum signal $(L+R)_p$ having a level controlled by the potentiometer 27. The potentiometer 27 controls the level of the sound image at center stage.

The left and right subsonically filtered input signals L_{in} and R_{in} are
10 provided as further inputs to the mixer 25. The mixer 25 combines the processed sum signal $(L+R)_p$ and the processed difference signal $(L-R)_p$ with the left and right input signals L_{in} and R_{in} to provide left and right output signals L_{out} and R_{out} . Particularly, the left and right output signals L_{out} and R_{out} are provided by the mixer 25 in accordance with the following:

15

$$L_{out} = L_{in} + K_1(L+R)_p + K_2(L-R)_p \quad (\text{Equation 1})$$

$$R_{out} = R_{in} + K_1(L+R)_p - K_2(L-R)_p \quad (\text{Equation 2})$$

20 The value of K_1 is controlled by the potentiometer 27; and the value of K_2 is controlled by the potentiometer 23.

The overall effect of processing the difference signal $(L-R)$ is that the quieter difference signal components are boosted relative to the louder difference signal components. That is, the selective attenuation of the
25 difference signal followed by amplification provides a processed difference signal wherein the louder components may be comparable in level to their original levels while the quieter difference signal components have levels greater than their original levels.

The processing of the sum signal $(L+R)$ is to raise the level of the sum
30 signal so that it is not overwhelmed by the selective boosting of difference signal components.

The potentiometers 23, 27 are user controlled elements to allow the user to control the respective levels of the processed sum signal $(L+R)_p$ and the processed difference signal $(L-R)_p$ that are mixed by the mixer 25. For
35 example, the potentiometers 23, 27 may be adjusted to minimize the processed difference signal and to maximize the processed sum signal. With

1 such adjustment, the listener would hear primarily any center stage soloist present in the recording being played.

The left and right output signals L_{out} and R_{out} are provided to the sound perspective correction system 200 of the stereo enhancement system 300 of FIG. 1. Alternatively, as discussed relative to the stereo enhancement system 300 of FIG. 1 and to the extent that the sound perspective correction system 200 is not utilized, the left and right output signals L_{out} and R_{out} are appropriately provided, for example, to the tape monitor loop input of the preamplifier tape monitor loop that provided the left and right stereo signals L and R.

B. The Feedback and Reverberation Control Circuit

Referring now to FIG. 3, shown therein is a block diagram of the feedback and reverberation control circuit 30 which includes a bandpass filter 32 that is responsive to the sum signal (L+R) and provides its output to an inverting peak detector 31. The output of the inverting peak detector 31 is an inverted sum signal envelope E_s . Preferably, the bandpass filter 32 has a -3 dB bandwidth of 4.8 KHz located between 200 Hz and 5KHz and a roll-off of 6 dB per octave. The bandpass filter 32 filters out the effects of clicks and pops that may be present in recordings, and further filters out high energy low frequency components which would have an undersirable effect on the control signals provided by the control circuit 30. The time constants of the peak detector circuit 31 provide a rise time in the order of one millisecond and a decay time in the order of one-half second.

The feedback and reverberation control circuit 30 further includes a bandpass filter 34 that is responsive to the difference signal (L-R) and provides its output to a non-inverting peak detector 33. The output of the non-inverting peak detector 33 is a non-inverted difference signal envelope E_d . The bandpass filter 34 has characteristics similar to those of the bandpass filter 32 and has a -3 dB bandwidth of 4.8 KHz located between 200 Hz and 5 KHz, and a roll-off of 6 dB per octave. The time constants of the peak detector circuit 33 provide a rise time in the order of one millisecond and a decay time in the order of one-half second.

The feedback and reverberation control circuit 30 includes another bandpass filter 36 that is responsive to the processed difference signal $(L-R)_p$ and provides its output to a non-inverting peak detector 35. The output of the non-inverting peak detector 35 is a non-inverted processed difference

1 signal envelope E_{dp} . The bandpass filter 36 has characteristics similar to
those of the bandpass filters 32, 34, and has a -3 dB passband of 4.8 KHz
located between 200 Hz and 5 KHz and a roll-off of 6 dB per octave. The
time constants of the peak detector 35 provide a rise time in the order of one
5 millisecond and a decay time in the order of one-half second.

The outputs of the inverting peak detector 31 and the non-inverting
peak detector 33 are respectively coupled to the fixed contacts of a
potentiometer 37. As discussed more fully further herein, the signal
available at the wiper contact of the potentiometer 37 is coupled to an
10 averaging circuit 60 which provides the reverberation control signal CTRL.

The output of the inverting peak detector 31 is further coupled to one
fixed terminal of a potentiometer 39 which has its other fixed terminal
coupled to ground. The inverted sum signal envelope E_s provided at the wiper
contact of the potentiometer 39 is coupled via a summing resistor 41 to the
15 summing junction 43 of an integrator 50. The non-inverted processed
difference signal envelope E_{dp} provided by the non-inverting peak detector
35 is also coupled to the summing junction 43 via a summing resistor 45.

The integrator 50 further includes an operational amplifier 47 which has
its inverting input connected to the summing junction 43 and has its non-
20 inverting input connected to ground. An integrating capacitor 49 is connected
between the output of the operational amplifier 47 and the summing
junction 43. A zener clamp diode 51 is coupled between the output of the
operational amplifier and the summing junction 43, and the functions to limit
the maximum level of the control signal CTRL provided by the operational
25 amplifier 47.

Further, the integrator 50 includes a zener diode 53 and a switch 55
serially coupled between the output of the operational amplifier 47 and the
summing junction 43. The zener diode 53 has a value that is about in the
middle of the output swing of the operational amplifier 47 as controlled by
30 the zener clamp diode 51. The switch 55 is controlled by a difference signal
detector 57 which is responsive to the difference signal envelope E_d provided
by the peak detector 33. Specifically, the difference signal detector 57
controls the switch 55 to close and clamp the level of the integrator output
CTRL when little or no difference signal envelope E_d is present. By way of
35 example, the difference signal detector 57 may be a voltage comparator (or

1 an operational amplifier biased as a voltage comparator) with an appropriate threshold reference near zero.

The switched clamp circuit including the zener diode 53 and the switch 55 prevent a substantial increase in the gain provided by the gain controlled amplifier 22 when the left and right input signals L_{in} and R_{in} contain very little or no stereo information. Without such a switched clamp circuit, left and right input signals containing very little or no stereo information would cause the integrator output CTRL to go to its maximum level since very little or no processed difference signal would be present. Such maximum level of the control signal CTRL would cause the gain controlled amplifier 22 to provide maximum gain, and when the input signals L_{in} and R_{in} subsequently contain stereo information, the processed difference signal would be dramatically amplified to the detriment of the audio equipment and listeners' comfort.

15 An alternative arrangement (not shown) of the switched clamp circuit 50 completely eliminates that one feedback path of amplifier 47 which includes zener diode 53 and switch 55. In such alternative arrangement, the switch 55 is connected between the summing junction 43 and the connection of the feedback path of capacitor 49, diode 51 to the inverting input to amplifier 47. The switch is still operated from the output of difference signal detector 57, which in this case, is connected to cause the switch to open when the difference signal detector 57 detects loss of the difference signal. Thus, with the loss of difference signal in such an alternative arrangement, the charge on integrating capacitor 49 remains frozen and, because the capacitor remains connected to the amplifier at all times, remains at the level existing upon the opening of the switch. Therefore the control signal from the output of amplifier 47 will not increase upon loss of the difference signal.

The output of the integrator 50 is the gain control signal CTRL and is indicative of the sum of (a) the inverted sum signal envelope E_s provided to the summing junction 43 and (b) the non-inverted processed difference signal envelope E_{dp} provided to the summing junction 43. The gain control signal CTRL is utilized to vary the gain applied to the difference signal (L-R) by the gain controlled amplifier 22 (FIG. 1) so that the sum of the sum and processed difference signal envelopes E_s , E_{dp} applied to the summing resistors 41, 45 of the integrator 50 tends toward zero. Thus, the non-inverted processed

1 difference signal envelope E_{dp} provided to the summing junction 43 tends to
inversely track or follow the inverted sum signal envelope E_s provided to the
summing junction 43. Stated another way, the processed difference signal $(L-$
2 $R)_p$ is adjusted by the control signal CTRL in such a way that the non-
5 inverted processed difference signal envelope E_{dp} tends to be equal and
opposite to the inverted sum signal envelope E_s provided at the wiper contact
of the potentiometer 39.

Referring to FIG. 2, the control circuit 30 and the gain controlled
amplifier 22 in essence cooperate to maintain a predetermined ratio between
10 the sum signal $(L+R)$ provided by the summing circuit 13 and the processed
difference signal $(L-R)_p$ provided by the gain controlled amplifier 22. That
predetermined ratio is set by the potentiometer 39 (FIG. 3).

As mentioned earlier, the averaging circuit 60 is responsive to the
signal at the wiper contact of the potentiometer 37. The signal at the wiper
15 contact of the potentiometer 37 is the sum of the inverted sum signal
envelope E_s and the non-inverted difference signal envelope E_d , where the
amount contributed by each envelope to the sum of envelopes is determined
by the position of the wiper contact. Since the sum signal envelope is
inverted and the difference signal is non-inverted, the sum of envelopes will
20 tend to go to zero if the sum and difference envelopes at the wiper contact
are close to being equal and opposite.

The averaging circuit 60 includes an operational amplifier 59 and an
input resistor 61 coupled between the inverting input of the operational
amplifier 59 and the wiper contact of the potentiometer 37. The non-
25 inverting input of the operational amplifier 59 is connected to ground, and
the output of the operational amplifier is the reverberation control signal
RCTRL. A capacitor 63 and a resistor 65 are coupled in parallel between the
output of the operational amplifier 59 and its inverting input. Effectively,
the averaging circuit 60 is an integrator with a resistor coupled across the
30 integrating capacitor.

So long as the sum of envelopes signal at the wiper contact of the
potentiometer 37 is near zero, the reverberation control signal provided by
the averaging circuit 60 is near zero. When the contribution of the sum
signal envelope to the sum of envelopes signal at the wiper contact becomes
35 predominant, the level of the reverberation control signal RCTRL increases.
The predominance of the contribution of the sum signal, as determined by the

1 setting of the potentiometer 37, indicates the possible presence of a center
stage soloist, which in turn indicates the possibility of artificial reverberation
in the difference signal.

In essence, the potentiometer 37 and the averaging circuit 60 cooperate
5 to provide the reverberation control signal RCTRL when the ratio between
(a) the inverted sum signal envelope E_s and (b) the non-inverted difference
signal envelope E_d exceeds a predetermined value. That predetermined value
is determined by the setting of the potentiometer 37. The reverberation
control signal RCTRL is indicative of the amount by which that predeter-
10 mined ratio is exceeded.

The reverberation control signal RCTRL provided at the output of the
averaging circuit 60 is utilized to provide further controls to the reverber-
ation bands (referenced previously in regard to FIG. 2 and centered at 500
Hz, 1 KHz, and 2 KHz) of the dynamic difference signal equalizer 19 and the
15 dynamic sum signal equalizer 21. Specifically, the reverberation control
signal RCTRL causes the dynamic difference signal equalizer 19 to provide
further attenuation in the reverberation bands and causes the dynamic sum
signal equalizer 21 to provide further boost in the reverberation bands. As
mentioned previously, reverberation compensation of the processed sum
20 signal may alternatively be achieved by selectively amplifying the output of
the dynamic sum signal equalizer 21 with a gain controlled amplifier (not
shown) pursuant to control by the reverberation control signal RCTRL. Such
an arrangement is illustrated in FIG. 10 and described in detail below.

Since artificial reverberation is generally manifested in the difference
25 signal components in the above-referenced reverberation bands, the further
attenuation caused by the reverberation control signal RCTRL reduces the
boost provided to any artificial reverberation that may be present. The
further boost to the sum signal components in the reverberation bands is to
compensate for any artificial reverberation which may not have been
30 sufficiently attenuated by the dynamic difference signal equalizer 19.

Preferably, the potentiometer 37 is adjusted so that the sum of
envelopes signal at the wiper contact is at a null or slightly biased toward the
difference signal for input stereo signals that do not include a soloist.

It should be noted that the input to the averaging circuit 60 may
35 alternatively be provided by other bandpass filter and peak detector cir-
cuitry, where each of such bandpass filters has a bandwidth which is more

1 suitable to the detection of the possibility of the presence of reverberation.

In the foregoing stereo image enhancement system 10, automatic enhancement adjustment and reverberation compensation have been provided for the following reasons.

5 It has been determined that the amount of stereo information present in recordings varies considerably from recording to recording. For example, one recording may be close to being monaural while another may have "ping-pong" stereo where a sound source appears to move from side-to-side. As a result of the recording to recording variation in stereo information, and also
10 such variation within a single recording, continual adjustment of the amount of enhancement may be required, and such adjustment is automatically and continually provided by the control circuit 30 and the gain controlled amplifier 22.

It has also been determined that recordings may include artificial
15 acoustical or electronic reverberation, for example, for soloists featured at center stage. Such artificial reverberation is generally manifested in the difference signal (L-R). Analysis of a variety of recordings revealed that the primary energy of artificial reverberation is in the range between 250 Hz and 2500 Hz, particularly as to male and female vocalists. Such artificial
20 reverberation may be a function of one or more of the vocal formants, possibly the first and/or second. See "The Acoustics of the Singing Voice," J. Sundberg, 1977, The Physics of Music, Scientific American, W.H. Freeman & Company.

When the processed difference signal $(L-R)_p$ is increased for greater
25 stereo enhancement, any artificial reverberation that may be present is also increased and may under some circumstances overwhelm the processed sum signal $(L+R)_p$. The presence of artificial reverberation is compensated by the control circuit 30 in cooperation with the selected reverberation bands of the difference signal equalizer 19 and the sum signal equalizer 21.

30 In the foregoing stereo image enhancement system 10, the sum signal equalizer 21 and the difference signal equalizer 19 are dynamically controlled by the spectrum analyzer 17, and in that sense the system is referred to as the dynamic stereo image enhancement system 10. Alternatively, a simplified non-dynamic equalization or fixed equalization stereo image enhance-
35 ment system may be provided which does not include the spectrum analyzer 17 and which provides for fixed equalization of the sum and difference

1 signals.

C. The Fixed Stereo Image Enhancement System

Referring particularly to FIG. 4, shown therein is a block diagram of a statistical or fixed stereo image enhancement system 110 which includes a left input signal subsonic filter 112 and a right input signal subsonic filter 114 which are responsive to left and right stereo signals L and R provided by a stereo sound reproduction system (not shown). For example, as discussed above relative to the stereo enhancement system 300 of FIG. 1, the left and right stereo signals L and R may be provided by a preamplifier tape monitor loop output. The subsonic filters 112, 114 provide subsonically filtered input signals L_{in} and R_{in} to a summing circuit 111 and a difference circuit 113.

As discussed above relative to the dynamic stereo image enhancement system of FIG. 2, the subsonic filters 112, 114 afford protection against damage due to dropping a phono cartridge.

15 The difference circuit 111 subtracts the right signal R_{in} from the left signal L_{in} to provide a difference signal (L-R), and the summing circuit 113 adds the subsonically filtered left and right input signals L_{in} and R_{in} to provide a sum signal (L+R).

The difference signal (L-R) provided by the difference circuit 111 is provided to a fixed difference signal equalizer 115 which selectively attenuates the difference signal as a function of frequency. The fixed difference signal equalizer 115 is substantially similar to the fixed difference signal equalizer 18 of the dynamic stereo image enhancement system 10 of FIG. 2, and an appropriate equalization characteristic is shown in FIG. 5A. By way of example, the fixed difference signal equalizer 115 may include a plurality of parallel filter stages including a low pass filter and a high pass filter having the following characteristics. The low pass filter has a -3 dB frequency of about 200 Hz, a roll-off of 6 dB per octave, and a gain of unity. The high pass filter has a -3 dB frequency of about 7 KHz, a roll-off of 6 dB per octave, and a gain of one-half.

As discussed further herein, further amplification for the equalized difference signal output of the fixed difference equalizer 115 is provided by a gain controlled amplifier 125. Such amplification may also be provided, at least in part, by the fixed difference signal equalizer 115. The output of the gain controlled amplifier 125 is coupled to a reverberation filter 129 which provides a processed difference signal $(L-R)_p$ as its output.

1 Referring again to FIG. 5A, it should be noted that the difference signal
is particularly attenuated in the range of about 1 KHz to about 4 KHz since
the human ear has greater sensitivity to such frequencies and since such
frequency range includes difference signal components having wavelengths
5 that are comparable to the distance between a listener's ears (the "frequencies
of increased phase sensitivity"). As discussed previously and relative to
the prior art, loud difference signals within such frequencies result in
annoying harshness and limit a listener to being located equidistant between
the speakers. By attenuating such frequencies, the harshness and the
10 limitation on location are substantially reduced.

The sum signal (L+R) provided by the summing circuit 113 is coupled to
a fixed sum signal equalizer 117. An appropriate equalization characteristic
for the fixed sum signal equalizer 117 is shown in FIG. 5B. By way of
example, the fixed sum signal equalizer 117 includes a bandpass filter which
15 has -3 dB frequencies at 200 Hz and 7 KHz and rolls off at 6 dB per octave.
The 200 Hz to 7 KHz bandwidth of the bandpass filter approximates the
operating range of the dynamic sum signal equalizer 21 of the dynamic stereo
image enhancement system 10 of FIG. 2.

It should be noted that the equalization characteristic of the fixed sum
20 signal equalizer 117 rolls off below 200 Hz at 6 dB per octave to avoid overly
emphasized bass. Moreover, there is very little difference signal in that
range, so that the processed sum signal in that range does not have to be
boosted very much.

As discussed further herein, further amplification of the processed sum
25 signal $(L+R)_p$ is provided by a gain controlled amplifier 127 which also
provides for artificial reverberation compensation. Such amplification may
also be provided, at least in part, by the fixed sum signal equalizer 117.

The equalization characteristics of the fixed equalizers 115, 117 and
the gains associated with the processed sum and difference signals are
30 intended to approximate the average behavior of the dynamic enhancement
system 10 of FIG. 1 for a large variety of recordings. Thus, the difference
signal components in the frequency ranges that statistically include predomi-
nantly quiet components are boosted relative to the difference signal
components in the frequency ranges that statistically include predominantly
35 louder components. The louder components of the difference signal are
typically in the mid-range, and the quieter components are on either side of

1 the mid-range. Particularly, the difference signal components in the mid-
range are attenuated to a greater degree than the difference signal compo-
nents on either side of the mid-range. The equalized signal is then boosted so
that the difference signal components on either side of the mid-range are
5 boosted relative to the difference signal components in the mid-range.

The enhancement system 110 further includes a feedback and reverber-
ation control circuit 40 which is substantially similar to the feedback and
reverberation control circuit 30 of FIG. 3. The control circuit 40 cooperates
with other elements in the system to provide for automatic adjustment of
10 stereo enhancement and for reverberation compensation.

The control circuit 40 is responsive to the difference signal (L-R)
provided by the difference circuit 111 and the sum signal (L+R) provided by
the summing circuit 113. The control circuit 40 provides a gain control signal
CTRL for controlling the gain controlled amplifier 125 which varies the gain
15 applied to the equalized difference signal provided by the fixed difference
signal equalizer 115. The control circuit 40 is further responsive to the
amplified difference signal provided by the gain controlled amplifier 125.
Particularly, the output of the gain controlled amplifier 125 would be
provided to the bandpass filter 36 of the control circuit 30 of FIG. 3.

20 The control circuit 40 controls the gain controlled amplifier 125 so as
to maintain a constant ratio between the sum signal (L+R) provided by the
summing circuit 111 and the difference signal provided by the gain controlled
amplifier 125.

The control circuit 40 further provides a reverberation control signal
25 RCTRL to the gain controlled amplifier 127 which provides for reverberation
compensation. By way of example, the gain controlled amplifier 127 may be
an appropriate voltage controlled amplifier.

The reverberation filter 129 is a variable rejection filter that includes
two one octave wide filters respectively centered at 500 Hz and 1.5 KHz, and
30 each having a low Q to provide sufficient bandwidth. Each of the filters of
the reverberation filter 129 may be similar to one of the equalizer bands in
the dynamic difference signal equalizer 19 of the dynamic stereo image
enhancement system 10 of FIG. 2, and provides a maximum attenuation of 12
dB for the maximum level of the reverberation control signal RCTRL. An
35 alternative reverberation filter is shown in FIG. 11 and described below.

1 By way of example, the gain controlled amplifier 125 may be an appropriate voltage controlled amplifier. The processed sum signal $(L+R)_p$ output of the gain controlled amplifier 127 is provided to a fixed terminal of a potentiometer 123 which has its other fixed terminal coupled to ground.
 5 The wiper contact of the potentiometer 123 is coupled to a mixer 121 which therefore receives the processed sum signal $(L+R)_p$ having a level controlled by the potentiometer 123.

The processed difference signal $(L-R)_p$ output of the reverberation filter 129 is coupled to a fixed terminal of a potentiometer 119 which has its
 10 other fixed terminal coupled to ground. The wiper contact of the potentiometer 119 is coupled to the mixer 121 which therefore receives the processed difference signal $(L-R)_p$ having a level controlled by the potentiometer 119.

The gain controlled amplifier 127 and the reverberation filter 129 are preferably controlled by the reverberation control signal RCTRL so that the
 15 resulting increase in the processed sum signal $(L+R)$ provided by the gain controlled amplifier 127 is less than the decrease in the processed difference signal $(L-R)_p$ provided by the reverberation filter 129. Increasing the level of the processed sum signal $(L+R)_p$ provided by the gain controlled amplifier 127 is to provide for a sufficient level of the processed sum signal $(L+R)_p$ to
 20 compensate for any artificial reverberation not sufficiently attenuated by the reverberation filter 129.

The left and right subsonically filtered input signals L_{in} and R_{in} are provided as further inputs to the mixer 121. The mixer 121 combines the
 25 processed difference signal $(L-R)_p$ and the processed sum signal $(L+R)_p$ with the left and right input signals L_{in} and R_{in} to provide left and right output signals L_{out} and R_{out} . The mixer 121 may be similar to the mixer 25 of the dynamic stereo enhancement system 10 of FIG. 1, and would provide the left and right output signals L_{out} , R_{out} in accordance with the following:

$$30 \quad L_{out} = L_{in} + K_1(L+R)_p + K_2(L-R)_p \quad (\text{Equation 3})$$

$$R_{out} = R_{in} + K_1(L+R)_p - K_2(L-R)_p \quad (\text{Equation 4})$$

The value of K_1 is controlled by the potentiometer 123; and the value
 35 of K_2 is controlled by the potentiometer 119.

1 The potentiometers 119, 123 are user controlled elements to allow the
user to control the levels of the processed difference signal $(L-R)_p$ and the
processed sum signal $(L+R)_p$ that are mixed by the mixer 121. For example,
the potentiometers 119, 123 may be adjusted to minimize the processed
5 difference signal and to maximize the processed sum signal. With such
adjustment, the listener would hear primarily any center stage soloist present
in the recording being played.

 The left and right output signals L_{out} and R_{out} are provided to the
sound perspective correction system 200 of the stereo enhancement system
10 300 of FIG. 1. Alternatively, as discussed relative to FIG. 1, to the extent
that the sound perspective correction system 200 is not utilized, the left and
right output signals L_{out} and R_{out} are appropriately provided, for example,
to the tape monitor loop input of the preamplifier that provided the left and
right stereo signals L and R.

15 D. The Perspective Correction System

 The sound perspective correction system 210 of FIG. 6 provides
perspective correction for (a) speakers located in front of the listener ("front
located speakers"); (b) headphones; and (c) speakers located to the side of the
listener ("side located speakers"), such as those in automobile doors. As used
20 herein, the term headphones shall refer to all headphones, including those
sometimes characterized as airline headsets. Generally, headphones can be
categorized as being (a) circumaural where the earcup surrounds the entire
large outer ear known as the pinna, (b) supraaural where the earcup sits on
the outer surface of the pinna, and (c) intraaural where the earcup fits within
25 the entrance to the ear canal.

 Referring specifically to FIG. 6, the sound perspective correction
system 210 includes a summing circuit 211 and difference circuit 213 which
are both responsive to left and right input L_{in} and R_{in} signals provided by a
stereo image enhancement system as described above or by a stereo sound
30 reproduction system (not shown). For example, as discussed above relative to
the stereo enhancement system 300 of FIG. 1, the left and right input signals
 L_{in} and R_{in} may be provided by the preamplifier tape monitor loop output of
such a stereo system.

 The summing circuit 211 adds the left and right input signals L_{in} and
35 R_{in} to provide a sum signal $(L+R)$, and the difference circuit 213 subtracts

1 the right signal R_{in} from the left signal L_{in} to provide a difference signal (L-R).

The sum signal (L+R) is provided to the input of a fixed sum signal equalizer 215 which provides for one equalization output that is coupled to the switchable terminal 2 of a two-position switch 217. The switchable terminal 1 of the two-position switch 217 is coupled to the output of the summing circuit 211. The switched terminal of the switch 217 provides a switched sum signal $(L+R)_s$.

The difference signal (L-R) is provided to the input of a fixed difference signal equalizer 221 which provides for one equalization output that is coupled to the switchable terminal 1 of a two-position switch 223. The switch 223 is ganged together with the switch 217 so that each is in the same corresponding position. The switchable terminal 2 of the switch 223 is coupled to the output of the difference circuit 213. The switched terminal of the switch 223 provides a switched difference signal $(L-R)_s$. The ganged two-position switches 217, 223 are controlled by the user, and are set as a function of whether (a) front located speakers are to be used, or (b) headphones or side located speakers are to be used. It should be readily apparent that in position 1, the fixed sum signal equalizer 215 is bypassed, and in position 2 the fixed difference signal equalizer 221 is bypassed.

The switched terminal of the switch 217 is connected as an input to a mixer 225, and the switched terminal of the switch 223 is also connected as an input to the mixer 225. The mixer 225 combines the switched sum signal $(L+R)_s$ and the switched difference signal $(L-R)_s$ to provide left and right output signals L_{out} and R_{out} . Particularly, the left and right output signals L_{out} and R_{out} are provided by the mixer 225 in accordance with the following:

$$L_{out} = (L+R)_s + (L-R)_s \quad (\text{Equation 5})$$

$$R_{out} = (L+R)_s - (L-R)_s \quad (\text{Equation 6})$$

Position 1 of the switches 217, 223 corresponds to sum and difference signals for use with front located speakers. Position 2 of the switches 217, 223 corresponds to sum and difference signals for use with headphones or side located speakers, such as in an automobile.

1 From the foregoing it should be evident that only the difference signal is equalized when front located speakers are utilized, and that only the sum signal is equalized when headphones or side located speakers are utilized.

5 Referring again to the fixed sum signal equalizer 215 and to the fixed difference signal equalizer 221, each includes a plurality of equalization bands which are about one-third octave wide. The following Tables I and II set forth the respective center frequencies of such equalizer bands and the amount of equalization provided.

10 Table I sets forth the equalization provided by the fixed difference signal equalizer 221 for the output connected to the switchable terminal 1 of the switch 223. As discussed above, the fixed sum signal equalizer 215 is bypassed when the switches 217, 223 are in position 1 (front speakers).

15 TABLE I

<u>Center Freq</u>	<u>Difference Signal Equalizer</u>
500 Hz	+ 5.0 dB
1 KHz	+ 7.5 dB
8 KHz	+15.0 dB

20 Table II sets forth the equalization provided by the fixed sum signal equalizer 215 for the output connected to the switchable terminal 2 of the switch 217. As discussed above, the fixed difference signal equalizer 221 is bypassed when the switches 217, 223 are in position 2 (headphones or side speakers).

25 TABLE II

<u>Center Freq</u>	<u>Sum Signal Equalizer</u>
500 Hz	- 5.0 dB
1 KHz	- 7.5 dB
8 KHz	-15.0 dB

1 The values set forth in Table I are representative values only and may
be modified on the basis of factors including speaker location and speaker
characteristics. Similarly, the values set forth in Table II are representative
values only, and with side located speakers may be modified on the basis of
5 factors including speaker location and speaker characteristics. With head-
phones, the values of Table II may also be modified on the basis of factors
including the type of headphone, as well as specific headphone characteris-
tics.

10 It should be noted that the equalization for headphones may differ from
the equalization for side placed speakers. With side located speakers, the
sound reaches the ear with little interference. However, with headphones,
the combined structure of the headphones and the ear influences the
spectrum of the sound reaching the eardrum. Moreover, the concha (the
section leading into the ear canal) and part of the ear canal may be occluded
15 by the headphone structure, which would further influence the spectrum of
sound reaching the eardrum. A discussion of the effects of airline entertain-
ment headsets on sound reproduction is set forth in "Some Factors Affecting
the Performance of Airline Entertainment Headsets," S. Gilman, J. Audio
Eng. Soc., Vol. 31, No. 12, December 1983, pp. 914-920.

20 The equalization provided by the sound perspective control system 210
can be further understood by reference to FIGS. 7A through 7D. FIG. 7A
represents a statistical average frequency response of the human ear to sound
emanating from zero degrees azimuth or straight ahead (herein the "front
response"). FIG. 7B represents a statistical average frequency response of
25 the human ear for sound emanating from 90 degrees azimuth as measured
relative to straight ahead (herein the "side response").

FIG. 7C is the front response relative to the side response, i.e., the
response of FIG. 7A (front) minus the response of FIG. 7B (side). Equalization
is required for sounds which should be emanating from the front but with side
30 located speakers or headphones are emanating from the sides. The response
of FIG. 7C is indicative of the equalization that would restore front sounds to
their appropriate levels when such sounds are reproduced by side located
speakers or headphones.

FIG. 7D is the side response relative to the front response, i.e., the
35 response of FIG. 7B (side) minus the response of FIG. 7A (front) provides the
response of FIG. 7D. Equalization is required for sounds which should be

1 emanating from the sides but are emanating from the front. The response of
FIG. 7D is indicative of the equalization that would restore side sounds to
their appropriate levels when such sounds are reproduced by forward placed
speakers.

5 The equalization characteristics of the equalizers 215, 221 are based on
the response of FIGS. 7C and 7D, but do not provide the entire equalization
indicated by such responses. It has been determined that equalization bands
of one-third octave widths respectively centered at 500 Hz, 1 KHz, and 8
KHz are sufficient. The characteristics of each equalization band have been
10 discussed previously.

The foregoing has been a disclosure of a stereo sound perspective
correction system which provides for a stereo image having a corrected
stereo sound perspective. It is readily utilized with or without the disclosed
stereo image enhancement systems. Its use with a stereo image enhancement
15 system would provide for a stereo image which is wider, a greater listening
area when used with speakers, and proper sound perspective.

The disclosed implementation of the sound perspective correction
system of the invention is not complex and effectively utilizes only a few
narrow equalization bands. As discussed above, the relative responses of the
20 front and side responses to one another tend to indicate that wider ranges of
equalization should be utilized, but the few narrow equalization bands have
been found to be a reasonable approximation over the entire audio bandwidth.

As previously mentioned, principles of the present invention are appli-
cable either for playback of conventional stereo sound recordings or for the
25 manufacture of unique stereo sound recordings which will provide advantages
described above when played back through conventional sound responsive
systems. Thus, as illustrated in Fig. 8, for playback of a conventional sound
recording, an exemplary system having the enhancement described herein
includes a conventional playback apparatus 300 which may respond to a
30 digital record, such as a laser disc, a phonograph record, a magnetic tape, or
the sound channel on video tape or motion picture film. The playback
apparatus provides left and right channel stereo signals L,R to a preamplifier
302 from which the left and right signals are fed to the stereo image
enhancement system 100 described above to provide processed output signals
35 L_{out} and R_{out} fed either directly to a pair of conventional loudspeakers 304,

1 306 or fed to the speakers via the perspective correction system 200
previously described.

A similar arrangement is used in making a recording that will itself
bear data in the form of physical grooves of a phonograph record, magnetic
domains of a magnetic tape or like medium, or digital information that may
5 be read by optical means. Such data defines left and right stereo signals
formed of signal components that, when played back on a conventional sound
reproducing system, produce all of the advantages described above. Thus, as
illustrated schematically in Fig. 9, a recording system for making a sound
10 recording embodying principles of the present invention may receive left and
right stereo input signals from either a pair of microphones 310 or a
conventional stereo playback system 312 which is adapted to provide left and
right stereo input signals L,R. The playback system 312, like the system 300
of Fig. 8, may provide its output signals from any conventional record
15 medium including digital records such as a laser disc, phonograph records,
magnetic tape, or video or film sound track media.

Ganged switches 314, 316 schematically indicate in FIG. 9 that the
system may use either left and right signals from a playback device or the
left and right signals from a pair of microphones. These signals are fed to a
20 preamplifier 318 and thence to the stereo image enhancement circuit 100
described above. From the stereo image enhancement circuit 100, the
processed left and right output signals are fed either directly to a recording
device 320 or indirectly to the recording device via the above described
perspective correction circuit 200. The recording device conventionally
25 records the left and right output signals L_{out} and R_{out} on a record medium
322 which may be any one of the record medium types commonly employed.
It will be noted that the output signals L_{out} and R_{out} that are fed to
recording device 320 are derived, in the case of the stereo image enhance-
ment, from mixer 25 of Fig. 2 or mixer 21 of Fig. 4, or in the case of the
30 perspective correction from the mixer 225 of Fig. 6.

The output signal L_{out} recorded on the medium 322 includes the several
left channel output signal components described, namely the described
combination of $L_{in} + K_1(L+R)_p + K_2(L-R)_p$ for the left channel output.
Similarly, the output signal R_{out} is recorded upon the record medium by the
35 recording apparatus and includes the components described above as $R_{in} +$
 $K_1(L+R)_p - K_2(L-R)_p$.

1 The record medium 322, when recorded with the arrangement illustra-
ted in Fig. 9, is simply played back on a conventional sound recording
responsive device to provide the above-described advantages. These advan-
tages are derived from the fact that the record medium so produced
5 embodies signal-producing means that cooperates with the sound recording
responsive device to produce left and right output signals that comprise a
combination of signal components including a processed difference signal and
a processed sum signal. The processed difference signal is a modification of
an input difference signal formed in the stereo image enhancement circuit
10 100. This input difference signal represents the difference of the left and
right input signals L and R, and as previously described, has relative
amplitudes of certain components modified to boost those of its components
that are within frequency bands wherein the input difference signal has
lowest amplitude relative to those components of such input difference signal
15 that are within frequency bands wherein the input difference signal compo-
nents have highest amplitude. Similarly, the recording will produce a right
stereo output signal component as a processed sum signal formed in the
stereo image enhancement circuit 100. This processed sum signal component
is a modification of the sum of the left and right channel input signals, and,
20 as previously described, has relative amplitudes of certain components
modified to boost those of its components in frequency bands where the input
difference signal has higher amplitudes relative to those components of the
input sum signal that are within frequency bands where the difference signal
has lower amplitude. Thus, the record cooperates with the sound responsive
25 system to cause the speakers to produce left and right stereo signals each
having sum and difference components wherein amplitudes of such com-
ponents are relatively deemphasized or boosted, respectively, within those
frequency bands wherein the difference signal has lower amplitudes. More-
over, the operation of the gain control amplifier 22 and control circuit 30 of
30 Fig. 2, and the corresponding circuits of Fig. 4 cause the stereo output signals
produced by playback of record 322 to have a substantially constant ratio of
the sum signal to the modified or processed difference signal, all as
previously described.

35 When the system of Fig. 9 is employed to make a record having
perspective correction in addition to or instead of image enhancement, such a
record will cooperate with the conventional stereo player to produce left and

1 right stereo output signals having components including a processed sum
signal which are increasingly attenuated in frequency bands centered on 500
Hz, 1 KHz and 8 KHz, respectively, as described above, and a component
5 comprising a difference signal. Such a record is made specifically to be
played back through a system including side mounted speakers. Where a
perspective corrected record made with the system of FIG. 9 is specifically
made for playback in a system with front mounted speakers, the record when
played back on a stereo player will provide left and right stereo output
signals wherein one output signal has components comprising a sum signal and
10 a component comprising a difference signal, where such difference signal has
amplitudes thereof increasingly boosted in frequency bands centered respec-
tively at 500 Hz, 1 KHz and 8 KHz, as described above. Stated otherwise,
the recording having perspective correction for front speakers, when played
in a stereo player, produces a left output signal which is formed of the sum of
15 a first component comprising the sum signal and a second component
comprising the processed difference signal as set forth in equation 5 above
and will provide a right output stereo signal formed of the difference
between the sum signal and the processed difference signal as set forth in
equation 6 above. When such a recording is made for use with side mounted
20 speakers, only the sum signals in equations 5 and 6 are equalized whereas
when the recording is made for use with front mounted speakers only the
difference signals of equations of 5 and 6 are equalized.

It will be seen that a method of making unique stereo sound recordings
having stereo image enhancement, or perspective correction, or both may be
25 carried out by the apparatus illustrated in Fig. 9. The method generally
comprises combining left and right input signals to generate sum and
difference signals, and creating a processed sum signal by selectively altering
relative amplitudes of components of the sum signal within respective
predetermined frequency bands so as to enhance those of the sum signal
30 components which are within frequency bands of highest difference signal
component amplitudes relative to those of the sum signal components which
are within frequency bands of lowest difference signal component amplitudes.
The method also includes the step of creating a processed difference signal
by selectively altering the relative amplitude of components of the
35 difference signal within the predetermined frequency bands so as to deemph-
size those of the difference signal components which are within frequency

1 bands where difference signal components are highest relative to those of the
difference signal components which are within frequency bands wherein the
difference signal components are lowest. The method also combines the left
and right signals with the processed sum and difference signals to provide
5 enhanced right and left output signals which are fed to a sound recording
device to make a sound recording. Other features of the method include the
described electronic analysis of the frequency spectrum of the difference
signal and generation of control signals as a function of the amplitudes of the
difference signal within respective predetermined frequency bands, and
10 utilizing the control signals to determine the extent to which amplitudes of
components of the sum and difference signals are altered within the
respective frequency bands.

According to an important aspect of the method described herein, right
and left signals are added and subtracted to generate sum and difference
15 signals, a dynamic control signal is generated representing the amount of
stereo in the input signals, the sum and difference signals are processed for
enhancement of the output signals and at least one of the processed signals is
modified in accordance with the amount of stereo in the input signals. A
specific feature of this aspect of the method involves modification of one of
20 the processed signals, which is accomplished so as to maintain a constant
ratio between one of the sum and difference signals and the processed signal.
In use of the described method, for making a recording that is corrected for
perspective with side mounted speakers, left and right signals are combined
to provide sum and difference signals, the sum signal is equalized as
25 previously described and combined with the unprocessed difference signal to
provide a left output formed of the sum of the processed sum signal and the
unprocessed difference signal and to form a right output signal comprising
the difference between the processed sum signal and the unprocessed
difference signal. These output signals are fed to the recording mechanism
30 to provide a record medium having perspective correction for side mounted
speakers.

For front mounted speakers, a perspective corrected record medium is
made by combining the right and left input signals to provide sum and
difference signals, equalizing the difference signal as previously described,
35 and combining the unprocessed sum signal with the equalized difference
signal to provide a left output formed of the sum of the unprocessed sum

1 signal and the processed or equalized difference signal and to provide a right
output signal formed of the difference between the unprocessed sum signal
and the equalized difference signal. These output signals are fed to a
recording mechanism to produce a record medium having perspective correc-
5 tion for front speakers.

A record made by the apparatus and method described herein is
uniquely distinguished from other stereo records in that unique signal
generating data is embodied in the record. Whether such data is in the form
of variable magnetic elements, varying grooves of a phonograph record or
10 digital information such as variations in optical reflectivity of a laser or
digital disc, for example, the unique aspects of such a record medium are
readily recognizable. Upon playback of such an unique record by convention-
al record playing medium, stereo sound will be produced having all of the
above-described advantages and composed of the specified signal compo-
15 nents.

The amount of enhancement is continually and automatically adjusted
by control circuit 30 and gain controlled amplifier 22 to compensate for
variation in the amount of stereo information from one recording to another
when using the described system for playback of conventional recordings. So
20 too, such continuous and automatic adjustment is embodied in a recording
made as indicated in Fig. 9. Thus, if the stereo information contained in a
record employed in the playback system 312, or, if the stereo information
reaching the microphone pair 310, should vary either from one recording to
the next or should vary during any given performance or recording, the
25 described control circuit 30 and gain control amplifier 22 will result in
adjustment of the amount of enhancement in the information recorded on the
record medium 322 and, therefore, result in such adjustment of output signals
when record medium 322 is played back in a conventional system.

As described above and illustrated in FIG. 4, where fixed sum and
30 difference equalizers are employed, amplitude of the processed sum channel
signal is boosted, and certain frequencies of the processed difference signal
are attenuated under control of the reverberation control signal RCTRL.
This arrangement provides automatic control of the amount of reverberation
by automatically increasing the level of the processed sum channel signal and
35 concomitantly decreasing the level of certain frequencies of the difference
channel signal. These increases and decreases in signal levels are effected in

1 the reverberation bands, as described above, to reduce boost of natural or
artificial reverberation that may be present, which boost is provided by the
enhancement circuits described herein. A similar reverberation control is
also described above in connection with the arrangement illustrated in FIG. 2,
5 in which the reverberation control signal is employed to cause the dynamic
difference signal equalizer 19 to provide further attenuation in the reverberation
bands and to cause the dynamic sum signal equalizer 21 to provide
further boost to the sum signal components.

Reverberation control illustrated in FIG. 2 may be considerably im-
10 proved by providing an automatic reverberation control through the use of a
gain controlled amplifier in the sum channel and an attenuating reverberation
filter in the difference channel. Such an improved arrangement is illustrated
in FIG. 10, which shows a system substantially similar to that illustrated in
FIG. 2, having many of the same components. Components which are the
15 same in both FIGS. 2 and 10 are designated by the same reference numerals
with the corresponding components of FIG. 10 having the prefix "4" so that
for example, summing circuit 13 of FIG. 2 is the same as summing circuit 413
of FIG. 10. The arrangement of FIG. 10 differs from that of FIG. 2 generally
by providing an automatically and manually controllable reverberation con-
20 trol signal, which is employed to control a gain controlled sum channel
amplifier 440, and the addition of a reverberation signal controlled reverberation
filter 429 (analogous to reverberation filter 129 of the fixed
equalizer arrangement of FIG. 4) to handle the processed difference signal.
In the circuit of FIG. 10 the tendency of the described enhancement circuits
25 to provide excessive emphasis of reverberation in the inputs is automatically
and selectively restrained.

Control circuit 430 is identical to the control circuit illustrated in FIG.
3 but the reverberation signal, RCTRL, provided from this circuit is derived
from the manually adjustable wiper arm 442 of a reverberation control
30 potentiometer 444, to which is fed the reverberation control signal from the
output of amplifier 59 of FIG. 3. The reverberation control signal from wiper
442 is fed to control the gain of the gain controlled amplifier 440 to which is
fed the output $(L + R)_p$ of dynamic sum signal equalizer 421. The output of
gain controlled amplifier 440 is fed to a potentiometer 427 for input to the
35 mixer 425, just as described in connection with the output of dynamic sum
signal equalizer 21 of FIG. 2. In this case the reverberation control signal is

1 not fed to the dynamic difference signal equalizer nor to the dynamic sum
signal equalizer directly.

The processed difference signal from the output of gain controlled
amplifier 422 is fed to the input of a reverberation filter 429 of which the
5 output is fed to potentiometer 423 and thence to mixer 425 just as described
in connection with the output of the gain controlled amplifier 22 of FIG. 2.

The reverberation filter 429 may be the same as reverberation filter
129 illustrated in FIG. 4. However, it is presently preferred to employ a
reverberation filter arranged as illustrated in FIG. 11, which is basically a
10 variable attenuation band reject filter. As illustrated in FIG. 11, the
processed difference signal $(L-R)_p$ is fed to the filter input and thence in
parallel to a lowpass filter 450, a highpass filter 452, and a bandpass filter
454. The output of the bandpass filter 454 is fed to a controlled attenuating
circuit 456 having the reverberation control RCTRL as its controlling input.
15 The three outputs, from filters 450 and 452 and from the attenuator 456, are
combined and fed to the inverting input of a differential amplifier 458 having
its noninverting input grounded, thus providing at its output 450 the gain
controlled and reverberation filter controlled processed difference signal to
be fed to the potentiometer 423. The filter sections of the reverberation
20 filter 429 collectively provide a lowpass up to about 250 hertz, a highpass
above about 4 kilohertz, and a controlled attenuation bandpass between about
400 hertz and 2.5 kilohertz.

Therefore, in a manner similar to the operation of the fixed equali-
zation arrangement of FIG. 4, the circuit of FIG. 10 provides for sensing of
25 the amount of reverberation, whether natural or artificial, in the input
signals and provides a reverberation control signal RCTRL based upon such
sensed reverberation. The control signal RCTRL boosts the processed sum
signal and attenuates a frequency band of the processed difference signal so
as to automatically control the effect of the described enhancement system
30 on the amount of reverberation in the input signal. The automatic control of
reverberation is manually selectable by manual control of the potentiometer
444, a feature that is of great importance in the recording industry. Close
selective adjustment of the amount of reverberation is required in making a
recording, and in particular in making a new or re-recording of an old
35 recording. Thus any undesired enhancement of reverberation that may be
introduced by the described enhancement circuitry is readily avoided by the

1 automatic control of both sum and difference channels and by the manually
selectable control of the level of the reverberation control signal itself. Of
course the manual control of the level of the reverberation control signal as
illustrated in FIG. 10 may be readily applied to obtain manual control of the
5 level of the reverberation control signal RCTRL shown in the circuit of FIG.
4, which is fed to control the reverberation filter 129.

Overall, the foregoing has been a disclosure of systems for substantially
improving the stereo image resulting from recorded performances, both in
playback of conventional records and in the production of improved re-
cordings. Such systems are readily utilized with standard audio equipment
and are readily added to installed audio equipment. Further, the disclosed
10 systems may be easily incorporated into preamplifiers and/or integrated
amplifiers. Such incorporation may include provisions for bypassing the
disclosed systems.

15 The disclosed stereo enhancement system is readily implemented using
analog techniques, digital techniques, or a combination of both. Further, the
disclosed stereo enhancement system is readily implemented with integrated
circuit techniques.

Also, the disclosed systems may be utilized with or incorporated into a
20 variety of audio systems including airline entertainment systems, theater
sound systems, recording systems for producing recordings which include
image enhancement and/or perspective correction, and electronic musical
instruments such as organs and synthesizers.

Further, the disclosed systems would be particularly useful in automo-
25 tive sound systems, as well as sound systems for other vehicles such as boats.

Although the foregoing has been a description and illustration of
specific embodiments of the invention, various modifications and changes
thereto can be made by persons skilled in the art without departing from the
scope and spirit of the invention as defined by the following claims.

CLAIMSWhat is claimed is:

- 1 1. A stereo image enhancement system for use in a stereo system having
respective left and right signals, comprising:

means for providing the sum of the left and right signals as a sum
signal and for providing the difference between the left and right
5 signals as a difference signal;

processing means responsive to said sum and difference signals for
selectively altering the relative amplitudes of components of said
difference signal within respective predetermined frequency bands so as
to boost difference signal components as an inverse function of the
10 level of difference signal components within said respective frequency
bands to provide a processed difference signal, and for selectively
altering the relative amplitudes of components of said sum signal within
said respective predetermined bands so as to boost sum signal compo-
nents as a function of the level of difference signal components within
15 said respective frequency bands to provide a processed sum signal; and

means for combining said processed difference signal, said pro-
cessed sum signal, and the left and right signals to provide left and
right output signals.

- 1 2. The stereo image enhancement system of claim 1 wherein said pro-
cessing means comprises:

analytical means for analyzing the frequency spectrum of said
difference signal for providing control signals respectively associated
5 with said predetermined frequency bands as a function of the ampli-
tudes of components of said difference signal within said respective
frequency bands;

first equalizing means responsive to said control signals for
attenuating components of said difference signal as a function of said
control signals so that louder components of said difference signal are
10 attenuated more than quieter components of said difference signal;

second equalizing means responsive to said control signals for
boosting components of said sum signal within said predetermined

15 frequency bands as a function of said control signals to provide said
processed sum signal; and

control means for amplifying said attenuated difference signal to
provide said processed difference signal.

1 3. The stereo image enhancement system of claim 2 wherein said first
equalizing means further provides predetermined fixed attenuation of se-
lected difference signal components.

1 4. The stereo image enhancement system of claim 3 wherein said selected
difference signal components include difference signal components between 1
KHz and 4 KHz.

1 5. The stereo image enhancement system of claim 2 wherein said control
means amplifies said attenuated difference signal as a function of the
magnitude of the said processed difference signal relative to that of the sum
5 amounts of stereo information within a given recording or between different
recordings.

1 6. The stereo image enhancement system of claim 5 wherein said control
means maintains said processed difference signal and said sum signal at a
constant ratio.

1 7. The stereo image enhancement system of claim 6 wherein said control
means comprises:

means for amplifying said attenuated difference signal to provide
said processed difference signal; and

5 gain control means responsive to said sum signal and said pro-
cessed difference signal for controlling the gain of said amplifying
means to maintain said constant ratio.

1 8. The stereo image enhancement system of claim 2 wherein said control
means further monitors the relative magnitudes of said sum signal and said
difference signal to detect conditions indicative of the presence of artificial
reverberation, and controls said second equalizing means pursuant to detec-

- 5 tion of conditions indicative of the presence of artificial reverberation to
compensate the effects of artificial reverberation.
- 1 9. The stereo image enhancement system of claim 8 wherein said control
means controls said second equalizing means to provide further attenuation in
selected ones of said predetermined frequency bands pursuant to detection of
conditions indicative of the presence of artificial reverberation.
- 1 10. The stereo image enhancement system of claim 9 wherein said control
means further controls said first equalizing means pursuant to detection of
conditions indicative of the presence of artificial reverberation to compen-
sate the effects of artificial reverberation.
- 1 11. The stereo image enhancement system of claim 10 wherein said control
means controls said first equalizing means to provide further boost in
selected ones of said predetermined frequency bands pursuant to detection of
conditions indicative of the presence of artificial reverberation.
- 1 12. The stereo image enhancement system of claim 11 wherein said control
means monitors the ratio between said sum signal and said difference signal,
and controls said first equalizing means and said second equalizing means
when said ratio exceeds a predetermined value.
- 1 13. The stereo enhancement system of claim 2 wherein said analytical
means comprises a spectrum analyzer.
- 1 14. The stereo enhancement system of claim 13 wherein said first and
second equalizing means respectively comprise a first multi-band dynamic
equalizer and a second multi-band dynamic equalizer.
- 1 15. The stereo enhancement system of claim 14 wherein said spectrum
analyzer and said first and second multi-band dynamic equalizers respectively
include predetermined frequency bands centered at 125 Hz, 250 Hz, 500 Hz, 1
KHz, 2 KHz, 4 KHz, and 8 KHz.

1 16. A stereo enhancement system for use with a stereo sound reproduction
system having respective left and right signals, comprising:

means for providing the difference of the left and right signals as
a difference signal and for providing the sum between the left and right
5 signals as a sum signal;

analytical means responsive to said difference signal for deter-
mining the frequency content of said difference signal;

10 first equalizing means responsive to said analytical means for
selectively attenuating components of said difference signal as a
function of the frequency content of said difference signal to provide a
processed difference signal;

15 second equalizing means responsive to said analytical means for
selectively boosting components of said sum signal as a function of the
frequency content of corresponding components of said difference
signal to provide a processed sum signal;

enhancement and reverberation control means for controlling the
ratio between said sum signal and said processed difference signal, and
for controlling said first and second equalizing means to compensate for
the effects of artificial reverberation; and

20 means for selectively combining said processed sum signal, said
processed difference signal, and the left and right signals to provide
left and right output signals.

1 17. A stereo enhancement system for use with a stereo sound reproduction
system having respective left and right signals, comprising:

5 means for providing the difference of the left and right signals as
a difference signal and for providing the sum of the left and right
signals as a sum signal;

10 processing means responsive to said sum and difference signals for
selectively altering the relative amplitudes of components of said
difference signal so as to boost selected difference signal components
relative to other difference signal components to provide a processed
difference signal, and for selectively altering the relative amplitudes of
said sum signal so as to boost selected sum signal components relative
to other sum signal components to provide a processed sum signal; and

means for combining said processed sum and difference signals and the left and right signals to provide processed left and right signals.

- 1 18. The stereo enhancement system of claim 17 wherein said processing means comprises:

5 first equalizing means for selectively attenuating difference signal components so as to attenuate frequencies that statistically include louder components more than frequencies that statistically include quieter components; and

10 second equalizing means for selectively passing sum signal components within a predetermined frequency range which statistically includes difference signal components, and for attenuating sum signal components outside said predetermined frequency range;

control means for amplifying said selectively passed sum signal to provide said processed sum signal and for amplifying said selectively attenuated difference signal to provide said processed difference signal.

- 1 19. The stereo enhancement system of claim 18 wherein said first and second equalizing means respectively include a first fixed equalizer and a second fixed equalizer.

- 1 20. The stereo enhancement system of claim 18 wherein said control means selectively amplifies said selectively attenuated difference signal as a function of its magnitude relative to that of the sum signal to provide a substantially consistent stereo image for differing amounts of stereo information within a given recording or between different recordings.

- 1 21. The stereo enhancement system of claim 20 wherein said control means maintains said amplified difference signal and said sum signal at a constant ratio.

- 1 22. The stereo enhancement system of claim 21 wherein said control means comprises:

means for amplifying said selectively attenuated difference signal; and

5 gain control means responsive to said sum signal and said amplified difference signal for controlling the gain of said amplifying means to maintain said constant ratio.

1 23. The stereo enhancement system of claim 18 wherein said control means monitors the relative magnitudes of said sum signal and said difference signal to detect conditions indicative of the presence of artificial reverberation, and further filters said amplified difference signal to compensate the effects
5 of artificial reverberation.

1 24. The stereo enhancement system of claim 23 wherein said control means further includes a variable rejection filter for variably attenuating selected components of said amplified difference signal to compensate the effects of artificial reverberation.

1 25. The stereo enhancement system of claim 24 wherein said control means further amplifies said selectively passed sum signal to compensate the effects of artificial reverberation.

1 26. The stereo enhancement system of claim 25 wherein said control means includes a gain controlled amplifier for amplifying said selectively passed sum signal to compensate the effects of artificial reverberation.

1 27. The stereo enhancement system of claim 26 wherein said control means monitors the ratio between said sum signal and said difference signal, and controls said variable rejection filter and said gain controlled amplifier when said ratio exceeds a predetermined amount.

1 28. A sound perspective correction system for use in a stereo system having respective left and right signals, comprising:

5 means for providing the sum of the left and right signals as a sum signal and for providing the difference between the left and right signals as a difference signal;

first means for equalizing said sum signal within predetermined frequency bands to provide a processed sum signal, said first equalizing means selectively attenuating said sum signal within said predetermined

10 frequency bands when the sound perspective correction system is
utilized with headphones or speakers located to the sides of the
listener; and

second means for equalizing said difference signal within said
predetermined frequency bands to provide a processed difference
signal, said second equalizing means selectively boosting said difference
15 signal within said predetermined frequency bands when the sound
perspective correction system is utilized with speakers located in front
of the listener;

means for selectively combining said processed sum and dif-
ference signals, to provide processed left and right signals.

1 29. The sound perspective correction system of claim 28 wherein said first
equalizing means includes a first fixed equalizer, and wherein said second
equalizing means includes a second fixed equalizer.

1 30. The sound perspective correction system of claim 29 wherein said first
and second fixed equalizers have equalization bands of about one-third octave
width.

1 31. The sound perspective correction system of claim 30 wherein said first
and second fixed equalizers, respectively, have three equalization bands.

1 32. The sound perspective correction system of claim 31 wherein said three
equalization bands are centered at 500 Hz, 1 KHz, and 8 KHz.

1 33. A method of deriving stereo enhanced signals from the left and right
signals of a stereo sound system comprising the steps of:

a. electronically adding said left and right signals so as to
generate a sum signal, and electronically subtracting one of said left
5 and right signals from the other to generate a difference signal;

b. creating a processed sum signal by selectively altering the
relative amplitudes of components of said sum signal within respective
predetermined frequency bands so as to enhance those of said sum
signal components which are within frequency bands of highest dif-
10 ference signal component amplitudes relative to those of said sum

signal components which are within frequency bands of lowest difference signal component amplitudes;

15 c. creating a processed difference signal by selectively altering the relative amplitudes of components of said difference signal within said predetermined frequency bands so as to deemphasize those of said difference signal components which are within frequency bands wherein said difference signal components are highest relative to those of said difference signal components which are within frequency bands wherein said difference signal components are the lowest; and

20 d. combining said left and right signals with said processed difference signal, and with said processed sum signal to provide stereo enhanced left and right output signals.

1 34. The method of claim 33 wherein said steps of creating processed sum and difference signals are augmented by the step of electronically analyzing the frequency spectrum of said difference signal and generating a set of control signals as a function of the amplitudes of said difference signal within
5 said respective predetermined frequency bands, and utilizing said control signals to determine the extent to which the amplitudes of components of said sum and difference signals are altered within said respective frequency bands.

1 35. The method of claim 33 additionally including the additional step of continually and automatically amplifying said processed difference signal as a function of its magnitude relative to that of said sum signal so as to maintain a substantially consistent stereo separation between said left and right
5 signals for differing amounts of stereo information within a given recording or between different recordings.

1 36. The method of claim 35 wherein said step of continually and automatically amplifying said processed difference signal is performed so as to maintain a constant ratio between said processed difference signal and said sum signal.

1 37. The method of claim 33 including the additional step of selectively boosting components of said sum signal, and selectively attenuating com-

ponents of said difference signal within selected ones of said predetermined frequency bands in order to prevent inappropriate boosting of artificial reverberation information in said difference signal.

38. The method of claim 37 wherein said step of continually and automatically amplifying is accomplished by averaging the sum of (a) the inverted peak envelope of said sum signal, and (b) the non-inverted peak envelope of said difference signal so as to generate a reverberation control signal, and boosting and attenuating components of said sum and difference signals, respectively, as a function of said reverberation control signal.

39. The method of claim 33 wherein the step of combining each of said left and right signals with said processed difference signal and with said processed sum signal is in accordance with the equations:

$$L_{out} = L_{in} + K_1 (L+R)_p + K_2 (L-R)_p, \text{ and}$$

$$R_{out} = R_{in} + K_1 (L+R)_p + K_2 (L-R)_p,$$

where

- L_{out} = stereo enhanced left output signal,
 R_{out} = stereo enhanced right output signal,
 $(L+R)_p$ = processed sum signal,
 $(L-R)_p$ = processed difference signal,
 L_{in} = left signal,
 R_{in} = right signal,
 K_1 = first independent variable, and
 K_2 = second independent variable.

40. The method of claim 33 wherein the step of creating a processed sum signal is performed by selectively boosting said sum signal components in given ones of said frequency bands in direct proportion to the magnitude of said difference signal components in said given ones of said frequency bands.

41. The method of claim 40 wherein the step of creating a processed difference signal is performed by selectively boosting said difference signal components in given ones of said frequency bands in inverse proportion to the

5 magnitude of said difference signal components in said given ones of said
frequency bands.

1 42. A method of deriving stereo enhanced signals from the left and right
signals of a stereo sound system comprising the steps of:

5 a. electronically adding said left and right signals so as to
generate a sum signal, and electronically subtracting one of said left
and right signals from the other to generate a difference signal;

b. creating a processed sum signal by selectively altering the
relative amplitudes of components of said sum signal so as to boost
selected sum signal components relative to other sum signal com-
ponents;

10 c. creating a processed difference signal by selectively al-
tering the relative amplitudes of components of said difference signal
so as to boost selected difference signal components relative to other
difference signal components; and

15 d. combining said left and right signals with said processed
difference signal, and with said processed signal to provide stereo
enhanced left and right output signals.

1 43. The method of claim 42 wherein said step of creating a processed sum
signal includes the steps of:

5 filtering said sum signal so that components outside a pre-
determined frequency range which statistically includes difference sig-
nal components are attenuated; and

amplifying the filtered sum signal.

1 44. The method of claim 42 wherein said step of creating a processed
difference signal includes the steps of:

5 selectively attenuating difference signal components so as to
attenuate frequencies that statistically include louder components more
than frequencies that statistically include quieter components; and

amplifying the selectively attenuated difference signal signal so
as to boost selected difference signal components relative to other
difference signal components.

- 1 45. A sound perspective correction system for use with a stereo sound
reproduction system having respective left and right signals, comprising
means for providing the sum of the left and right signal as a sum
signal and providing the difference between the left and right signals as
5 a difference signal;
first means for equalizing said sum signal within predetermined
frequency bands to provide a processed sum signal, said first equalizing
means including means for selectively attenuating said sum signal
within said predetermined frequency bands to provide for perspective
10 correction;
second means for equalizing said difference signal within said
determined frequency bands to provide a processed difference signal,
said second equalizing means including means for selectively boosting
said difference signal within said predetermined frequency bands;
15 a mixer having first and second inputs and providing left and right
perspective corrected output signals,
first switch means for alternatively coupling either said sum
signal or said equalized sum signal to said first mixer input, and
second switch means connected for operation together with said
20 first switch means for alternatively coupling either said difference
signal or said equalized difference signal to the second input of said
mixer, whereby the sound perspective correction system may be uti-
lized with speakers located in front of or to the sides of a listener
according to the position of said first and second switch means.
- 1 46. The stereo image enhancement system of any one of claims 1 through 5,
7, 10 and 15, including right and left speakers connected to receive said left
and right output signals respectively.
- 1 47. The stereo image enhancement system of any one of claims 1 through 5,
7, 10 and 15 including recording means responsive to said means for
combining said processed difference signals for recording said left and right
output signals on a record medium.
- 1 48. The method of any one of claims 33, 34, 35, 36 and 38 including the step

of transducing said stereo enhanced left and right output signals into left and right output sound signals.

1 49. The method of any one of claims 33, 34, 35, 36, 38 and 39 including the step of recording said stereo enhanced left and right output signals on a record medium.

1 50. The sound perspective correction system of any one of claims 28, 29, 30, 31 and 32 including first and second sound reproducing means connected to respectively receive said processed left and right signals.

1 51. The sound perspective correction system of any one of claims 28, 29, 30, 31 and 32 including means responsive to said means for selectively combining said processed sum and difference signals for recording said processed left and right signals.

1 52. A system for enhancing left and right stereo signals provided from a source of stereo sound comprising

stereo image enhancement circuit means for processing the left and right input signals to provide processed stereo signals,

5 stereo sensing means responsive to left and right stereo input signals from said source of stereo sound for sensing the amount of stereo in said input signals,

first control means responsive to said stereo sensing means for generating a dynamic control signal representing such amount of stereo,

10 second control means responsive to said control signal for modifying one of said processed stereo signals in accordance with the amount of stereo in said input signal, and

means for combining said processed stereo signals to provide left and right output signals.

1 53. The system of claim 52 wherein said stereo sensing means comprises means responsive to said left and right stereo input signals for providing sum and difference signals respectively representing the sum of said left and right input signals and the difference of said left and right input signals, and
5 wherein said first control means includes means responsive to said sum and

difference signals for generating said dynamic control signal as a function of a predetermined relation between said sum and difference signals.

1 54. The system of claim 52 wherein said stereo image enhancement circuit
means includes sum and difference circuit means responsive to said left and
right stereo input signals respectively for generating sum and difference
signals respectively representative of the sum and difference of said left and
5 right stereo input signals, means for processing said sum and difference
signals to provide processed sum and difference signals which form said
processed stereo signals, said control means comprising means for modifying
one of said processed sum and difference signals in a sense to decrease
variation of a selected relation between said one of said processed sum and
10 difference signals, and one of said sum and difference signals.

1 55. The system of claim 52 wherein said stereo image enhancement circuit
means comprises circuit means responsive to said left and right stereo input
signals for generating sum and difference signals respectively representing
the sum and difference of said stereo input signals, difference signal
5 equalizer means responsive to said difference signal for selectively altering
components in different frequency bands of said difference signal to provide
a processed difference signal, and sum equalizer means responsive to said
sum signal for selectively altering components of said sum signal in different
frequency bands to provide a processed sum signal, said processed sum and
10 difference signals forming said processed stereo signals.

1 56. The system of claim 54 wherein said means for modifying one of said
processed sum and difference signals comprises means for maintaining a
substantially constant ratio between said sum signal and said processed
difference signal.

1 57. The system of claim 56 wherein said first control means includes means
for clamping said control signal to a predetermined magnitude in response to
a sensed amount of stereo in said input signals below a predetermined
amount.

- 1 58. The system of claim 53 including means for feeding to said second
control means a signal representing said one processed stereo signal as
modified by said first control means.
- 1 59. The system of claim 52 including means for transducing said left and
right output signals into left and right sound signals.
- 1 60. The system of claim 52 including the step of recording said left and
right output signals.
- 1 61. A method for enhancing left and right stereo input signals provided
from a source of stereo sound, said method comprising the steps of
processing the left and right input signals to provide processed stereo
signals,
5 sensing the amount of stereo in said input signals and generating a
dynamic control signal representing such amount of stereo,
employing said dynamic control signal to modify one of said
processed stereo signals in accordance with the amount of stereo in said
input signal to provide a modified processed signal, and
10 combining one of said processed stereo signals and said modified
processed stereo signal to provide left and right output signals.
- 1 62. The method of claim 61 including the step of transducing said left and
right output signals into left and right sound signals.
- 1 63. The method of claim 61 including the step of recording said left and
right output signals.
- 1 64. The method of claim 61 wherein said step of sensing comprises the
steps of providing sum and difference signals respectively representing the
sum of said left and right input signals and the difference of said left and
right input signals, and wherein said step of generating a dynamic control
5 signal comprises generating said dynamic control signal as a function of a
predetermined relation between said sum and difference signals.

1 65. The method of claim 61 including the step of generating sum and
difference signals respectively representing the sum and difference of said
left and right stereo input signals, processing said sum and difference signals
to provide process sum and difference signals which form said processed
5 stereo signals, said step of employing said dynamic control signal comprising
modifying one of said processed sum and difference signals in a sense to
decrease variation of a predetermined relation between said one of said
processed sum and difference signals and that one of said sum and difference
signals which provides the other of said processed sum and difference signals.

1 66. The method of claim 61 wherein said step of processing the left and
right input signals comprises generating sum and difference signals respec-
tively representing the sum and difference of said left and right input signals,
selectively altering components in different frequency bands of said dif-
5 ference signal to provide a processed difference signal, and selectively
altering components of said sum signal in said different frequency bands to
provide a processed sum signal, said processed difference signal and pro-
cessed sum signals forming said processed stereo signals.

1 67. The method of claim 61 wherein said step of processing the left and
right input signals comprises generating sum and difference signals as the
sum and difference respectively of said left and right input signals, selec-
tively attenuating said sum signal within predetermined frequency bands and
5 combining said attenuated sum signal and said difference signal to provide
said left and right output signals.

1 68. The method of claim 61 wherein said step of processing the left and
right input signals comprises generating sum and difference signals as the
sum and difference respectively of said left and right input signals, selec-
tively boosting said difference signal within predetermined frequency bands
5 and combining said sum and said boosted difference signal to provide said left
and right output signals.

1 69. The method of claim 61 wherein said step of processing the left and
right input signals comprises generating sum and difference signals respec-
tively representative of the sum and difference of said left and right stereo

5 input signals, and processing said sum and difference signals to provide processed sum and difference signals which form said processed stereo signals and wherein said step of employing said dynamic control signal comprises modifying one of said processed sum and difference signals in a sense to maintain a constant ratio between said processed difference signal and said sum signal.

1 70. Apparatus for making a stereo enhanced sound recording from left and right stereo source signals comprising

- a. means for electronically adding said left and right signals to generate sum and difference signals;
- 5 b. means for creating a processed sum signal by selectively altering the relative amplitudes of components of said sum signal within respective predetermined frequency bands so as to enhance those of said sum signal components which are within frequency bands of highest difference signal component amplitudes relative to those of said sum signal components which are within frequency
10 bands of lowest difference signal component amplitudes;
- c. means for creating a processed difference signal by selectively altering the relative amplitudes of components of said difference
15 signal within said predetermined frequency bands so as to de-emphasize those of said difference signal components which are within frequency bands wherein said difference signal components are highest relative to those of said difference signal components which are within frequency bands wherein said difference signal components are the lowest;
- 20 d. means for combining said left and right signals with said processed difference signal, and with said processed sum signal to provide stereo enhanced left and right output signals;
- e. a sound recording device connected to receive said stereo enhanced left and right output signals; and
- 25 f. means for operating said sound recording device to make a sound recording.

1 71. The apparatus of claim 70 wherein said means for creating processed sum and difference signals comprises means for electronically analyzing the frequency spectrum of said difference signal and for generating a set of

- 5 control signals as a function of the amplitudes of said difference signal within said respective predetermined frequency bands, and means for utilizing said control signals to control the extent to which the amplitudes of components of said sum and difference signals are altered within said respective frequency bands.
- 1 72. The apparatus of claim 70 including means for continually and automatically amplifying one of said processed sum and difference signals as a function of its magnitude relative to that of one of said sum and difference signals so as to maintain a substantially consistent stereo separation between
5 said left and right signals for differing amounts of stereo information within said left and right stereo source signals.
- 1 73. The apparatus of claim 72 wherein said means for continually and automatically amplifying one of said processed sum and difference signals includes means for maintaining a constant ratio between said processed difference signal and said sum signal.
- 1 74. The apparatus of claim 70 including means for selectively boosting components of said sum signal, and means for selectively attenuating components of said difference signal within selected ones of said predetermined frequency bands in order to prevent inappropriate boosting of
5 artificial reverberation information in said difference signal.
- 1 75. The apparatus of claim 72 wherein said means for continually and automatically amplifying includes means for averaging the sum of (a) the inverted peak envelope of said sum signal, and (b) the non-inverted peak envelope of said difference signal so as to generate a reverberation control
5 signal, and means for boosting and attenuating components of said sum and difference signals, respectively, as a function of said reverberation control signal.
- 1 76. The apparatus of claim 70 wherein said means for combining left and right signals with said processed difference signal and with said processed sum signal combines said signals in accordance with the equations:

60

$$L_{out} = L_{in} + K_1(L+R)_p + K_2(L-R)_p, \text{ and}$$

$$5 \quad R_{out} = R_{in} + K_1(L+R)_p + K_2(L-R)_p,$$

where

L_{out} = stereo enhanced left output signal,

R_{out} = stereo enhanced right output signal,

$(L+R)_p$ = processed sum signal,

10 $(L-R)_p$ = processed difference signal,

L_{in} = left signal,

R_{in} = right signal,

K_1 = first independent variable, and

K_2 = second independent variable.

1 77. Apparatus for making a stereo sound recording from left and right stereo source signals comprising:

- a. means for electronically combining said left and right signals so as to generate sum and difference signals;
- 5 b. means for creating a processed sum signal by selectively altering the relative amplitudes of components of said sum signal so as to boost selected sum signal components relative to other sum signal components;
- c. means for creating a processed difference signal by selectively altering the relative amplitudes of components of said difference signal so as to boost selected difference signal components relative to other difference signal components;
- 10 d. means for combining said left and right signals with said processed difference signal, and with said processed sum signal to provide stereo enhanced left and right output signals; and
- 15 e. a sound recording device connected to receive said left and right output signals; and
- f. means for operating said sound recording device to make a sound recording.

1 78. Apparatus for making a stereo sound recording, corrected for perspective, from left and right stereo source signals comprising

means for electronically adding left and right signals to provide sum and difference signals,

5 means for equalizing said sum signal within predetermined frequency bands to provide a processed sum signal, said means for equalizing comprising the step of selectively attenuating said sum signal within said predetermined frequency bands, and

means for combining said selectively attenuated sum signal with said
10 difference signal to provide left and right perspective corrected output signals,

recording means for making a stereo sound recording connected to receive said left and right perspective corrected output signals, and

15 means for operating said recording means to make a stereo sound recording.

1 79. Apparatus for making a stereo sound recording, corrected for perspective, left and right stereo source signals comprising

means for electronically adding left and right signals to provide sum and difference signals,

5 means for equalizing said difference signal within predetermined frequency bands to provide a processed difference signal, said means for equalizing comprising means for selectively boosting said difference signal within said predetermined frequency bands,

10 combining said selectively boosted difference signal with said sum signal to provide left and right perspective corrected output signals,

recording means for making a stereo sound recording connected to receive said left and right perspective corrected output signals, and

means for operating said recording means to make a stereo sound recording.

1 80. A method of making a stereo enhanced sound recording from left and right stereo source signals comprising the steps of

a. electronically combining said left and right signals to generate sum and difference signals,

5 b. creating a processed sum signal by selectively altering the relative amplitudes of components of said sum signal within respective predetermined frequency bands so as to enhance those of said

- 10 sum signal components which are within frequency bands of highest difference signal component amplitudes relative to those of said sum signal components which are within frequency bands of lowest difference signal component amplitudes;
- 15 c. creating a processed difference signal by selectively altering the relative amplitudes of components of said difference signal within said predetermined frequency bands so as to deemphasize those of said difference signal components which are within frequency bands wherein said difference signal components are highest relative to those of said difference signal components which are within frequency bands wherein said difference signal components are the lowest;
- 20 d. combining said left and right signals with said processed difference signal, and with said processed sum signal to provide stereo enhanced left and right output signals;
- e. feeding said stereo enhanced left and right output signals to a sound recording device; and
- 25 f. operating said sound recording device to make a sound recording.

1 81. The method of claim 80 wherein said steps of creating processed sum and difference signals are augmented by the step of electronically analyzing the frequency spectrum of said difference signal and generating a set of control signals as a function of the amplitudes of said difference signal within

5 said respective predetermined frequency bands, and utilizing said control signals to determine the extent to which the amplitudes of components of said sum and difference signals are altered within said respective frequency bands.

1 82. The method of claim 80 additionally including the additional step of continually and automatically amplifying said processed difference signal as a function of its magnitude relative to that of said sum signal so as to maintain a substantially consistent stereo separation between said left and right

5 signals for differing amounts of stereo information within said left and right stereo source signals.

1 83. The method of claim 82 wherein said step of continually and auto-
matically amplifying said processed difference signal is performed so as to
maintain a constant ratio between said processed difference signal and said
sum signal.

1 84. The method of claim 80 including the additional step of selectively
boosting components of said sum signal and selectively attenuating com-
ponents of said difference signal within selected ones of said predetermined
5 frequency bands in order to prevent inappropriate boosting of artificial
reverberation information in said difference signal.

1 85. The method of claim 82 wherein said step of continually and auto-
matically amplifying is accomplished by averaging the sum of (a) the inverted
peak envelope of said sum signal, and (b) the non-inverted peak envelope of
said difference signal so as to generate a reverberation control signal, and
5 boosting and attenuating components of said sum and difference signals,
respectively, as a function of said reverberation control signal.

1 86. The method of claim 80 wherein the step of combining said left and
right signals with said processed difference signal and with said processed
sum signal is in accordance with the equations:

5
$$L_{out} = L_{in} + K_1(L+R)_p + K_2(L-R)_p, \text{ and}$$

$$R_{out} = R_{in} + K_1(L+R)_p + K_2(L-R)_p,$$

where

L_{out} = stereo enhanced left output signal,

10 R_{out} = stereo enhanced right output signal,

$(L+R)_p$ = processed sum signal,

$(L-R)_p$ = processed difference signal,

L_{in} = left signal,

R_{in} = right signal,

15 K_1 = first independent variable, and

K_2 = second independent variable.

- 1 87. A method of making a stereo sound recording from left and right stereo
source signals comprising the steps of:
- a. electronically combining said left and right signals so as to
generate sum and difference signals,
 - 5 b. creating a processed sum signal by selectively altering the rela-
tive amplitudes of components of said sum signal so as to boost
selected sum signal components relative to other sum signal
components;
 - 10 c. creating a processed difference signal by selectively altering the
relative amplitudes of components of said difference signal so as
to boost selected difference signal components relative to other
difference signal components;
 - d. combining said left and right signals with said processed dif-
ference signal and with said processed sum signal to provide
15 stereo enhanced left and right output signals; and
 - e. feeding said stereo enhanced left and right output signals to a
sound recording device; and
 - f. operating said sound recording device to make a sound recording.
- 1 88. The method of claim 87 wherein said step of creating a processed sum
signal includes the steps of:
- filtering said sum signal so as to attenuate components outside a
predetermined frequency range which statistically includes difference
5 signal components and amplifying the filtered sum signal.
- 1 89. The method of claim 87 wherein said step of creating a processed
difference signal includes the steps of:
- selectively attenuating difference signal components so as to
attenuate frequencies that statistically include louder components more
5 than frequencies that statistically include quieter components, and
amplifying the selectively attenuated difference signal components so
as to boost selected difference signal components relative to other
difference signal components.
- 1 90. A method of making stereo sound recording, corrected for perspective,
from left and right stereo source signals comprising the steps of

electronically combining left and right stereo source signals to provide sum and difference signals,

5 equalizing said sum signal within predetermined frequency bands to provide a processed sum signal, said equalizing comprising the step of selectively attenuating said sum signal within said predetermined frequency bands,

10 combining said selectively attenuated sum signal with said difference signal to provide left and right perspective corrected output signals,

feeding said left and right perspective corrected output signals to an apparatus for making a stereo sound recording, and operating said apparatus to make a stereo sound recording.

1 91. A method of making stereo sound recording, corrected for perspective, from left and right stereo source signals comprising the steps of

electronically combining left and right signals to provide sum and difference signals,

5 equalizing said difference signal within predetermined frequency bands to provide a processed difference signal, said step of equalizing comprising the step of selectively boosting said difference signal within said predetermined frequency bands,

10 combining said selectively boosted difference signal with said sum signal to provide left and right perspective corrected output signals,

feeding said left and right perspective corrected output signals to an apparatus for making a stereo sound recording, and

operating said apparatus to make a stereo sound recording.

1 92. A stereo enhanced sound recording made by the method of any one of claims 49 and 80 through 91, inclusive.

1 93. An enhanced image stereo sound recording for use in a sound recording playback system, said sound recording comprising

5 a record medium embodying signal producing means adapted to operate with a sound recording responsive device to produce left and right stereo output signals that are modifications of left and right

66

stereo source signals, said stereo output signals each comprising a combination of signal components including

- 10 (1) a processed difference signal which comprises a modification of an input difference signal representing the difference of said left and right stereo source signals,
- (2) a processed sum signal which comprises a modification of an input sum signal representing the sum of said left and right stereo source signals,
- 15 (3) one of said processed sum and difference signals and one of said input sum and difference signals having a predetermined relation that is substantially constant.

1 94. The sound recording of claim 93 wherein said processed difference signal includes components of said input difference signal boosted in quieter frequency bands where input difference signal amplitudes are relatively lower, relative to components in louder frequency bands wherein input
5 difference signal amplitudes are relatively higher, and wherein said processed sum signal includes components of said input sum signal that are boosted in said louder frequency bands relative to input sum signal components in said quieter frequency bands.

1 95. A stereo sound recording adapted to generate signal responses in a stereo player that is used in conjunction with a pair of speakers, said sound recording comprising

5 a record medium having signal producing means adapted to act on a sound recording responsive device of a stereo player to cause such sound recording responsive device to produce left and right stereo output signals that are modifications of left and right stereo source signals,

10 said left stereo output signal being composed of a combination of the following left components:

- (1) a left stereo source signal component,
- (2) a processed difference signal component that comprises a modification of an input difference signal representing the difference between left and right stereo source signals,

- 15 (3) a processed sum signal component that comprises a modification of an input sum signal representing the sum of left and right stereo source signals,

said right stereo output signal being composed of the following right components:

- 20 (1) a right stereo source signal component,
(2) a processed difference signal component that comprises a modification of an input difference signal representing the difference between said left and right stereo source signals,
25 (3) a processed sum signal component that comprises a modification of an input sum signal representing the sum of left and right stereo source signals.

1 96. The sound recording of claim 95 wherein said left stereo output signal is composed of the sum of said left components and wherein said right stereo output signal is composed of the difference between (a) the sum of said first and last mentioned right components and (b) said second mentioned right
5 component.

1 97. A stereo sound recording for use with a stereo player that is used in conjunction with a pair of speakers to cause the speakers to produce enhanced stereo sound, said sound recording comprising

5 a record medium having signal producing means adapted to act on a sound recording responsive device of a stereo player to cause said sound recording responsive device to produce left and right stereo signal outputs that are modifications of left and right stereo source signals,

- (a) said left signal stereo output having
10 1. a left stereo source signal component,
2. a processed difference signal component that comprises an input difference signal representing the difference between left and right stereo source signals modified to boost input difference signal components
15 in quieter frequency bands wherein input difference signal amplitudes are relatively low, relative to input difference signal components in louder frequency

bands wherein input difference signal amplitudes are relatively high, and

- 20 3. a processed sum signal component that comprises an input sum signal representing the sum of left and right stereo source signals modified to boost input sum signal components in said louder frequency bands relative to input sum signal components in said quieter frequency bands,

25

(b) said right stereo signal output having

1. a right stereo source signal component,
2. a processed difference signal component that comprises an input difference signal representing the difference between left and right stereo source signals modified to boost input difference signal components in quieter frequency bands wherein input difference signal amplitudes are relatively low, relative to input difference signal components in louder frequency bands wherein input difference signal amplitudes are relatively high, and
3. a processed sum signal component that comprises an input sum signal representing the sum of left and right stereo source signals modified to boost input sum signal components in said louder frequency bands relative to input sum signal components in said quieter frequency bands.

30

35

40

1 98. The stereo sound recording of claim 97 wherein the ratio of amplitudes of one of said input sum and difference signals to one of said processed sum and difference signal components is substantially constant.

1 99. The sound recording of claim 97 wherein one of said processed sum and difference signal components has an amplitude that varies in accordance with one of said input sum and difference signals to continually adjust the amount of processing of said one processed signal automatically according to the amount of stereo information present in said stereo source signals.

5

- 1 100. The stereo recording of claim 97 wherein said processed difference
signal component has a value that varies with variation of the ratio between
said input sum signal and said processed difference signal component.
- 1 101. The stereo sound recording of claim 97 wherein said input sum signal
and said input difference signal have components thereof in selected fre-
quency bands altered to compensate for effects of artificial reverberation.
- 1 102. The stereo sound recording of claim 97 wherein said input sum signal
and said input difference signal have amplitudes of components thereof
within predetermined reverberation frequency bands boosted and attenuated
as a function of the average of the sum of
- 5 (a) the inverted peak envelope of the sum signal, and
(b) the noninverted peak envelope of the difference signal.
- 1 103. The stereo sound recording of claim 97 wherein said input difference
signal is further modified to additionally boost input difference signal
components between 1KHz and 4KHz.
- 1 104. The stereo sound recording of claim 97 wherein said left stereo signal
output comprises the sum of said left stereo source signal component, said
processed difference signal component and said processed sum signal com-
ponent, and wherein said right stereo output signal comprises the difference
5 between (a) said processed difference component signal and (b) the sum of
said right stereo source component with said processed sum signal com-
ponent.
- 1 105. A stereo sound recording adapted to generate signal responses in a
stereo player that is used in conjunction with a pair of speakers to cause the
speakers to produce enhanced stereo sound, said sound recording comprising
a record medium having signal producing means adapted to act on
5 a sound recording responsive device of a stereo player to cause the
sound recording responsive device to produce left and right stereo
output signals that are modifications of left and right stereo source
signals and that are composed of a combination of the following
components:

- 10 (a) a perspective sum signal component representing the sum of left
and right stereo source signals, and
- (b) a perspective difference signal component representing the dif-
ference between left and right stereo source signals,
said perspective sum signal component having components thereof
15 in frequency bands centered on a plurality of mutually displaced
increasing frequencies which components are attenuated in progres-
sively greater amounts for such increasing frequencies.

1 106. The stereo sound recording of claim 105 wherein said frequency bands
are centered at about 500 Hz, 1 KHz and 8 KHz.

1 107. A stereo sound recording adapted to generate signal responses in a
stereo player that is used in conjunction with a pair of speakers to cause the
speakers to produce enhanced stereo sound, said sound recording comprising

5 a record medium having signal producing means adapted to act on
a sound recording responsive device of a stereo player to cause the
sound recording responsive device to produce left and right stereo
output signals that are modifications of left and right stereo source
signals and that are composed of a combination of the following
components:

- 10 (a) a perspective sum signal component representing the sum of left
and right stereo source signals, and
- (b) a perspective difference signal component representing the dif-
ference between left and right stereo source signals,
said perspective difference signal component having components
15 thereof in frequency bands centered on a plurality of mutually displaced
increasing frequencies which components are boosted in progressively
greater amounts for such increasing frequencies.

1 108. The stereo sound recording of claim 106 wherein said frequency bands
are entered at about 500 Hz, 1 KHz and 8 KHz.

1 109. An enhanced image stereo sound recording for use in a sound recording
playback system, said recording comprising

5 a record medium having signal producing means adapted to cooperate with a sound recording responsive device to produce left and right stereo output signals that are modifications of left and right stereo source signals,

said stereo output signals each comprising a combination of signal components including:

- 10 1. a processed difference signal which comprises a modification of an input difference signal representing the difference of said left and right stereo source signals and having the relative amplitude of components of such input difference signal modified to boost components of such input difference signal that are within frequency bands wherein the input difference signal has lowest amplitude relative to those components of such input difference signal that are within frequency bands wherein the input difference signal components have highest amplitude, and
- 15 2. a processed sum signal which comprises a modification of an input sum signal representing the sum of said left and right input signals and having the relative amplitudes of components of such input sum signal modified to boost components of said input sum signal in frequency bands of higher amplitude components of the input difference signal relative to components of said input sum signal in frequency bands of lower amplitude components of the input difference signal.

1 110. The enhanced image stereo sound recording of claim 109 wherein the ratio of one of said sum and difference signals and one of said processed sum and difference signals is substantially constant.

1 111. The enhanced image stereo sound recording of claim 109 wherein a predetermined substantially constant relation exists between one of said processed sum and difference signals and one of said input sum and difference signals.

- 1 112. The stereo image enhancement system of claim 1 including means for
generating a reverberation control signal indicative of the amount of
reverberation in said left and right signals, and means responsive to said
reverberation control signal for controlling the amount of reverberation in
5 said output signals.
- 1 113. The stereo image enhancement system of claim 112 wherein said last
mentioned means comprises means responsive to the reverberation control
signal for boosting the processed sum signal in accordance with reverberation
in said left and right signals and for attenuating said processed difference
5 signal in accordance with reverberation in said left and right signals.
- 1 114. The stereo image enhancement system of claim 112 wherein said last
mentioned means comprises means for attenuating said processed difference
signal in accordance with the amount of reverberation in said left and right
signals.
- 1 115. The stereo image enhancement system of claim 112 wherein said last
mentioned means comprises means responsive to said reverberation control
signal for boosting said processed sum signal in accordance with the amount
of reverberation in said left and right signals.
- 1 116. The stereo image enhancement system of claim 115 wherein said means
for boosting comprises a gain controlled amplifier having said processed sum
signal as an input thereto and having a gain control input receiving said
reverberation control signal.
- 1 117. The stereo image enhancement system of any one of claims 112, 113,
and 116 including manual means for controlling amplitude of said rever-
beration control signal.
- 1 118. The stereo image enhancement system of claim 52 including means for
generating a reverberation control signal indicative of the amount of
reverberation in said left and right stereo signals, and means responsive to
said reverberation control signal for controlling the amount of reverberation
5 in said output signals.

- 1 119. The system of any one of claims 54, 55 and 56 including means for
generating a reverberation control signal indicative of the amount of
reverberation in said left and right stereo signals, and means responsive to
said reverberation control signal for boosting said processed sum signal and
5 attenuating said processed difference signal in accordance with the amount
of reverberation in said left and right stereo signals.
- 1 120. The method of claim 61 or 66 wherein said left and right output signals
provide enhanced stereo output including enhanced reverberation components
and including the steps of sensing the amount of reverberation in said left and
right stereo input signals and generating a reverberation control signal
5 indicative of sensed reverberation, and employing the reverberation control
signal to modify the processed stereo signals so as to decrease the amount of
enhanced reverberation in said left and right output signals.
- 1 121. The apparatus of claim 70 including means for generating a rever-
beration control signal indicative of the amount of reverberation in said left
and right stereo source signals, and means responsive to said reverberation
control signal for controlling the amount of reverberation in said stereo
5 enhanced left and right output signals.
- 1 122. The method of claim 80 including the step of generating a reverberation
control signal indicative of the amount of reverberation in said left and right
stereo source signals, and employing said reverberation control signal to
modify said processed sum and processed difference signals to control the
5 amount of reverberation in said stereo enhanced left and right output signals.
- 1 123. The method of claim 84 wherein said step of selectively boosting
components of said sum signal comprises the steps of generating a rever-
beration control signal indicative of the amount of reverberation in said left
and right stereo source signals and amplifying said sum signal in accordance
5 with said reverberation control signal.
- 1 124. The method of claim 123 including the step of manually varying the
magnitude of said reverberation control signal to thereby provide both

automatic and manual control of the amount of reverberation in said stereo enhanced left and right output signals.

1 125. A system for enhancing left and right input signals provided from a source of stereo sound comprising

stereo image enhancement circuit means for processing the left and right input signals to provide left and right enhanced stereo signals,

5 reverberation sensing means responsive to the left and right input signals for generating a reverberation control signal indicative of the amount of reverberation in said left and right input signals, and

means responsive to said reverberation control signal for decreasing the amount of enhancement in said left and right enhanced stereo output signals
10 in accordance with the amount of reverberation in said left and right stereo input signals.

1 126. The system of claim 125 wherein said stereo image enhancement circuit means comprises circuit means responsive to said left and right input signals for generating sum and difference signals respectively representing the sum and difference of said input signals, difference equalizer means responsive to
5 said difference signal for selectively altering components in different frequency bands of said difference signal to provide said enhanced difference signal, and sum equalizer means responsive to said sum signal for selectively altering components of said sum signal in different frequency bands to provide said enhanced sum signal, and wherein said means responsive to said
10 reverberation control signal comprises means for attenuating said enhanced difference signal in accordance with said reverberation control signal and means for boosting said enhanced sum signal in accordance with said reverberation control signal.

1 127. A stereo enhanced sound recording made by the method of any one of claims 120, 122, 123 and 124.

1 128. The stereo sound recording of claim 97 wherein said processed difference signal component of both said left and right stereo signal outputs includes a band of frequencies having an amplitude that is attenuated in accordance with the amount of reverberation in the left and right stereo

- 5 source signals, and wherein the processed sum signal components of both said left and right stereo signal outputs is boosted in accordance with the amount of reverberation in said left and right stereo source signals.

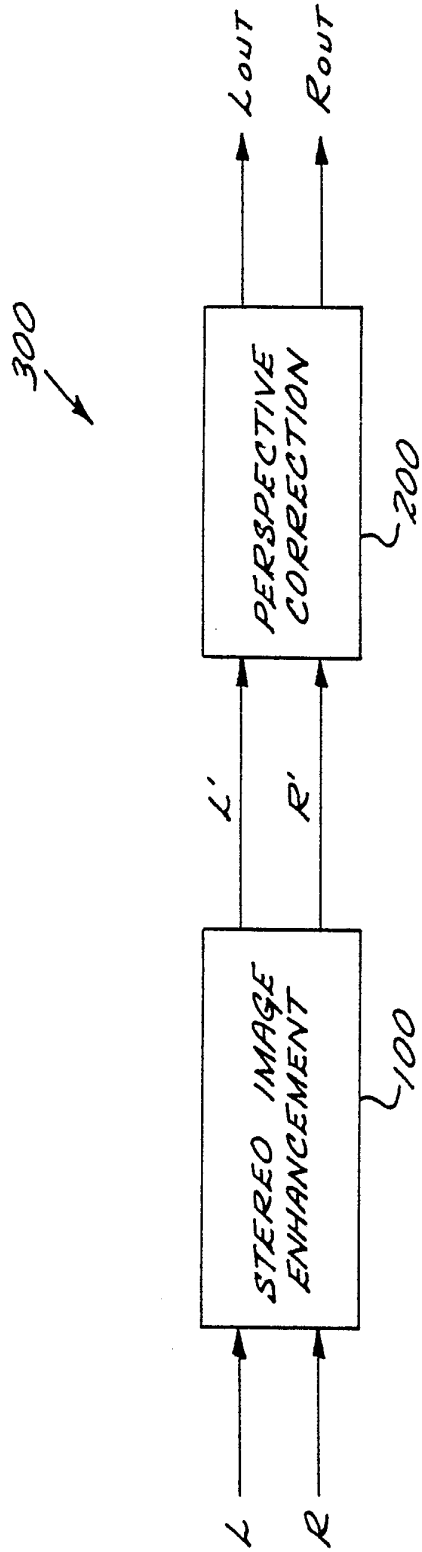

FIG. 1

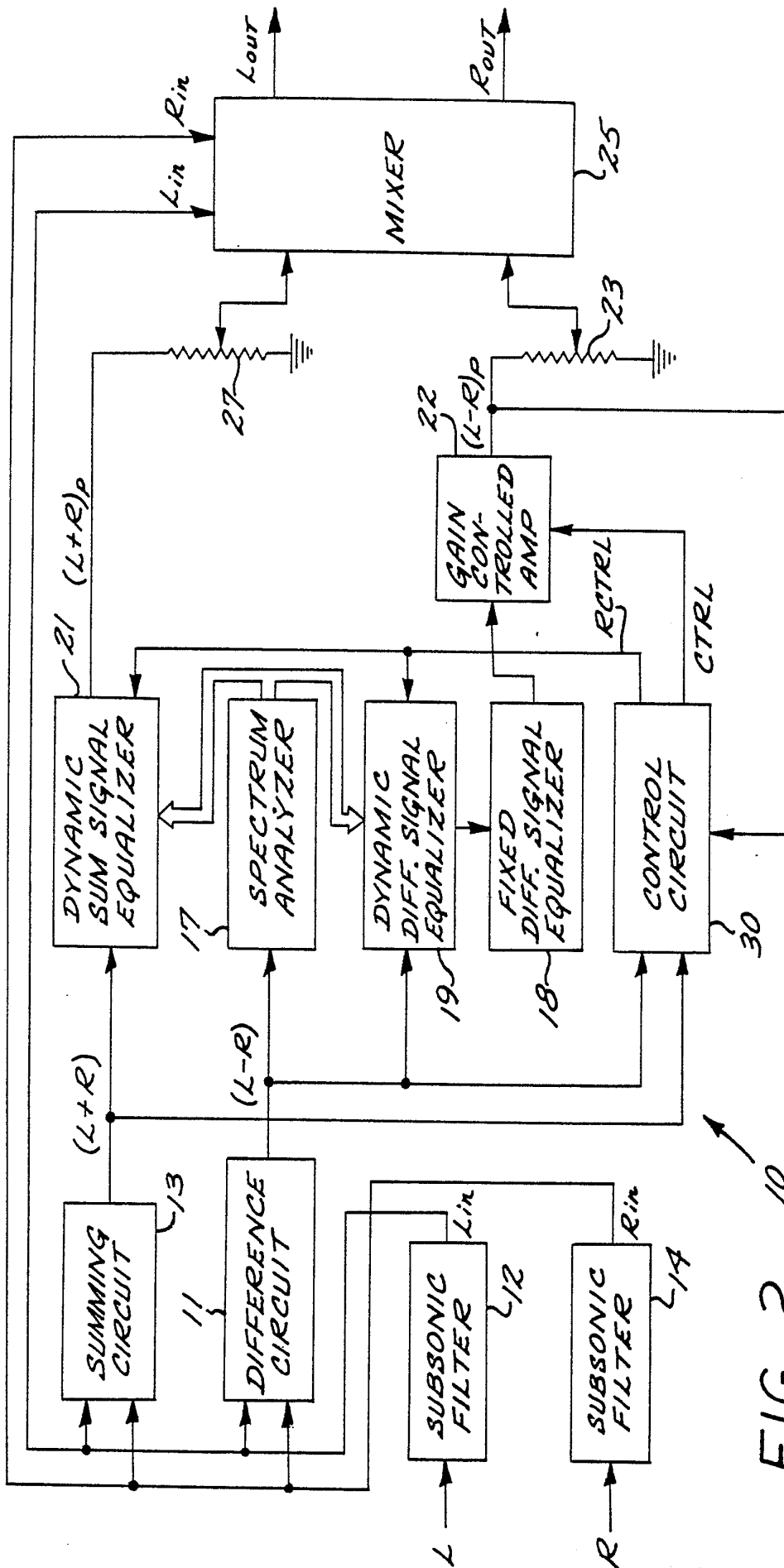

FIG. 2

10

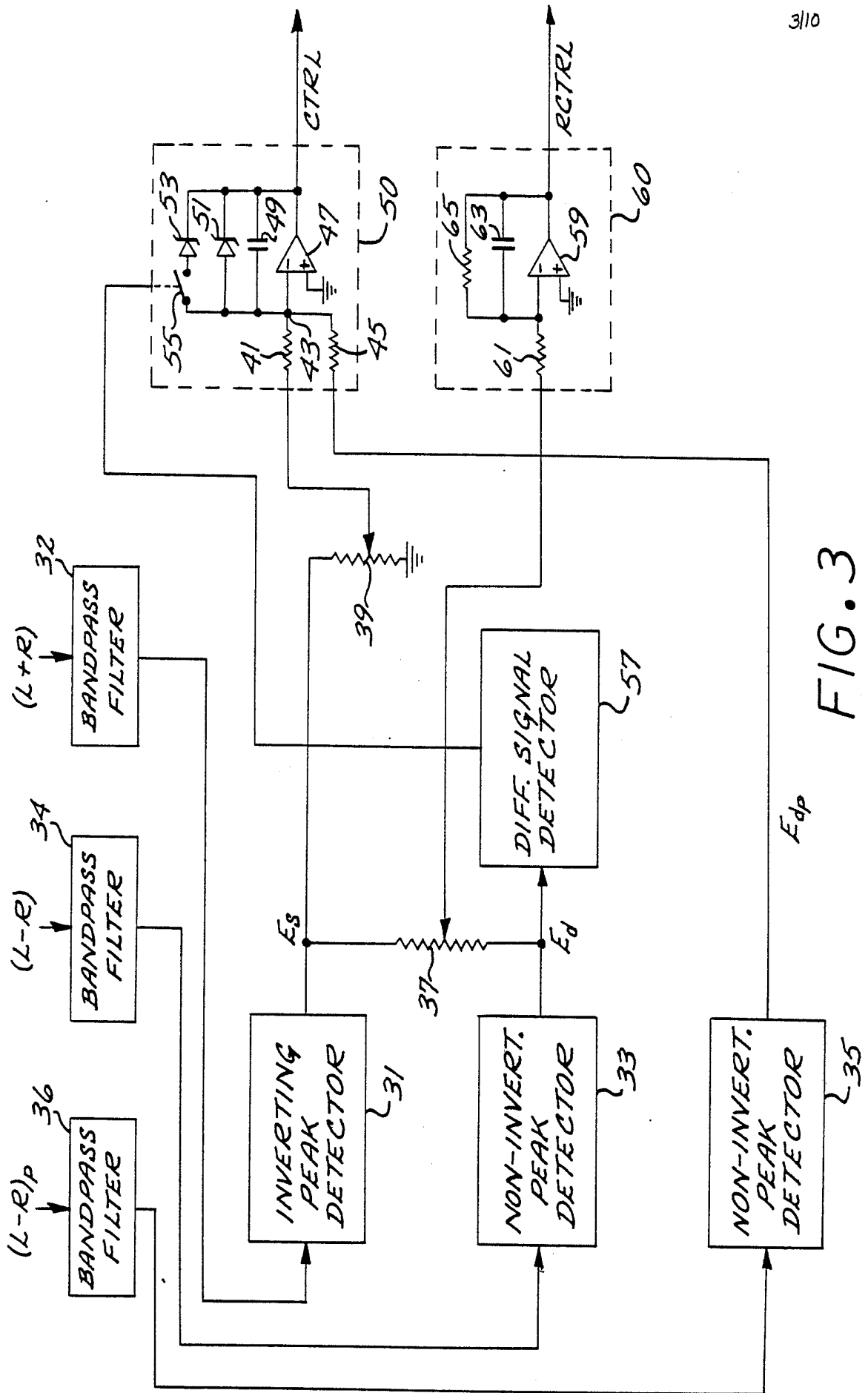

FIG. 3

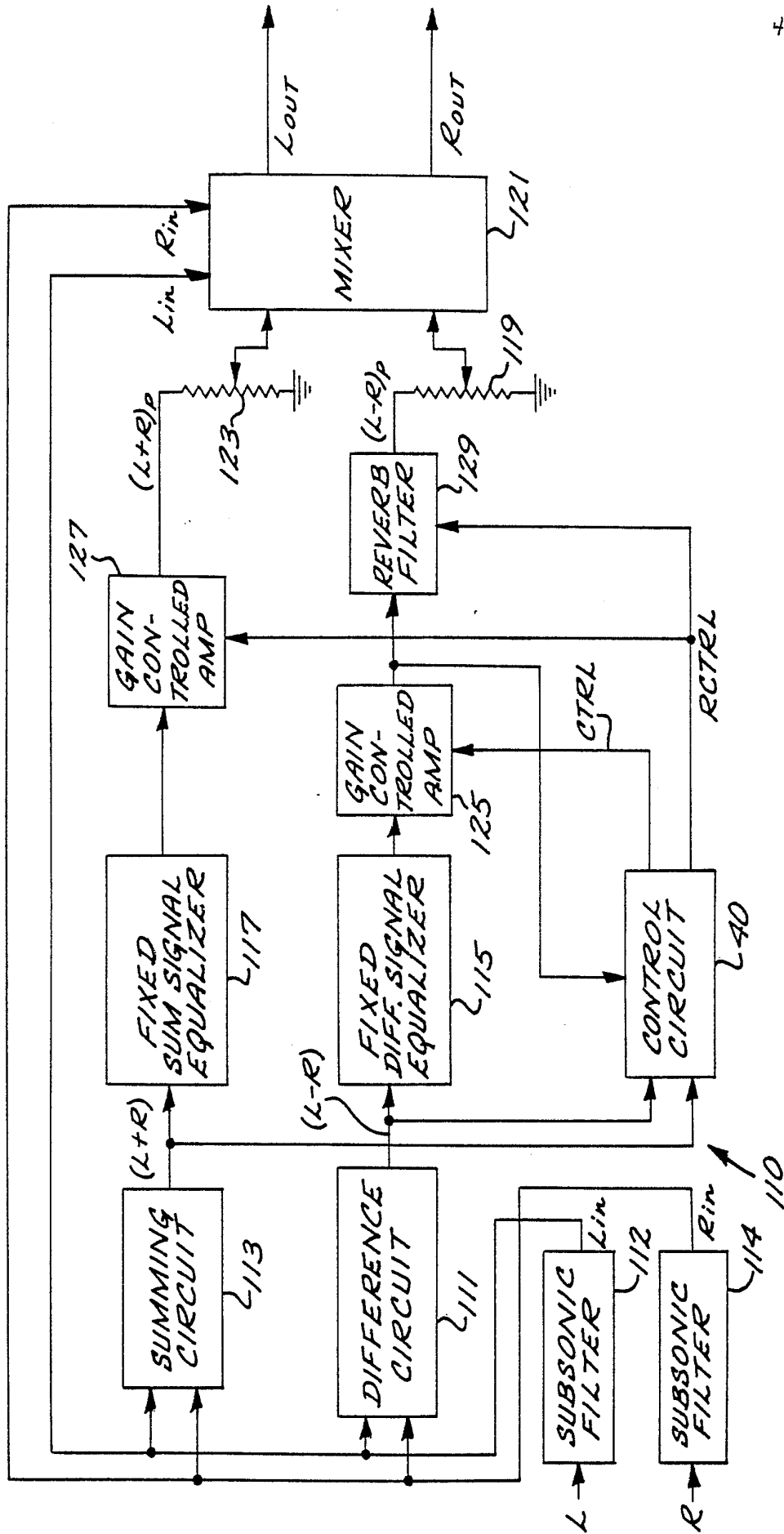

FIG. 4

5/10

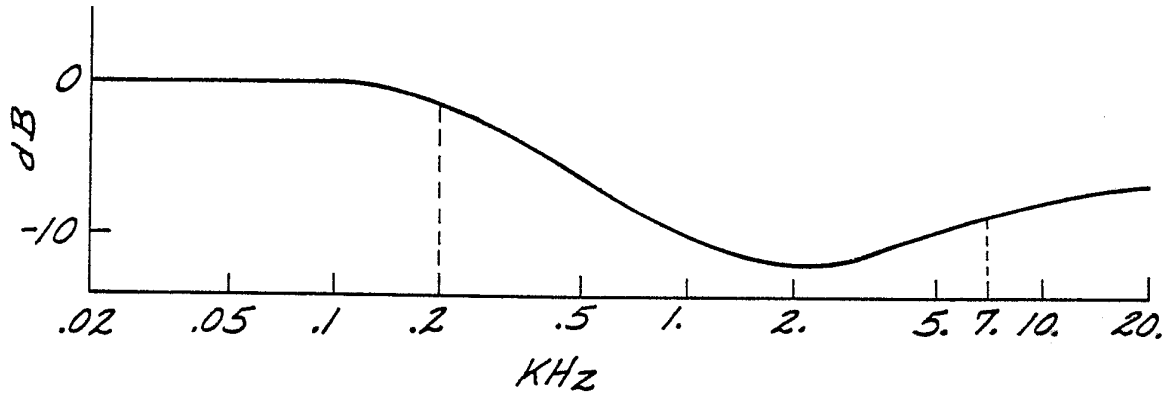

FIG. 5A

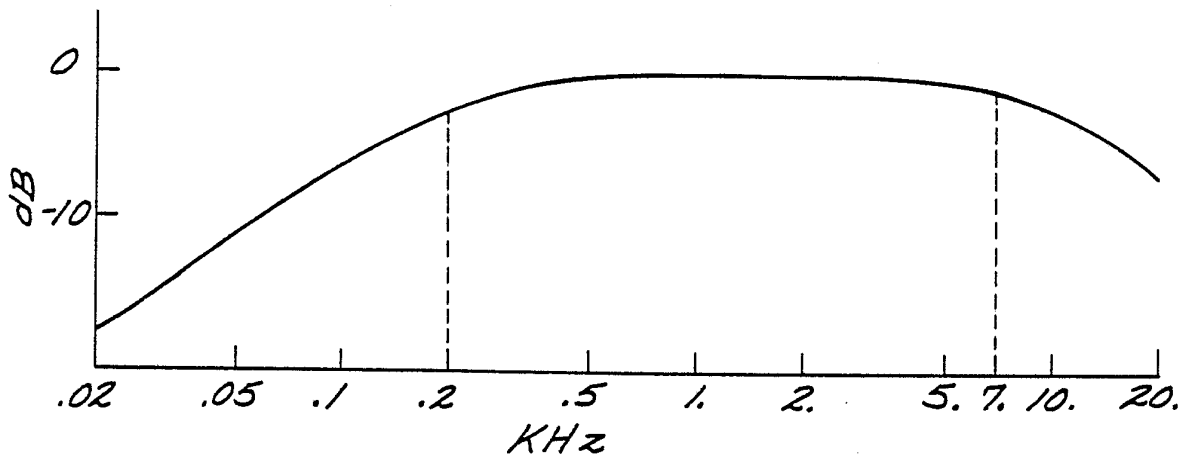

FIG. 5B

G/10

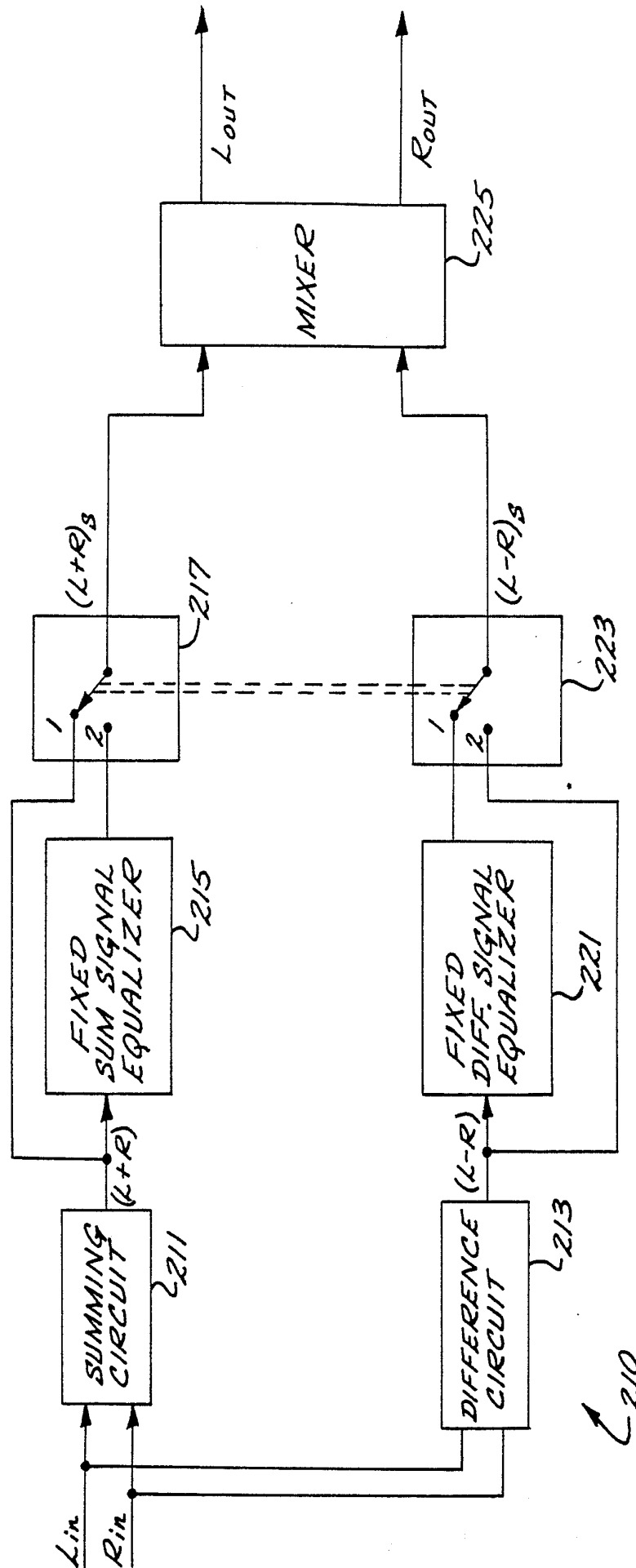

FIG. 6

FIG. 7A

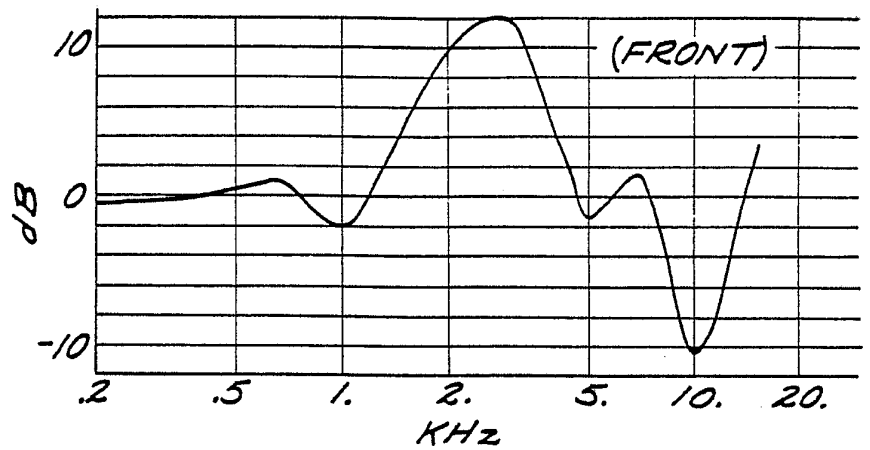

FIG. 7B

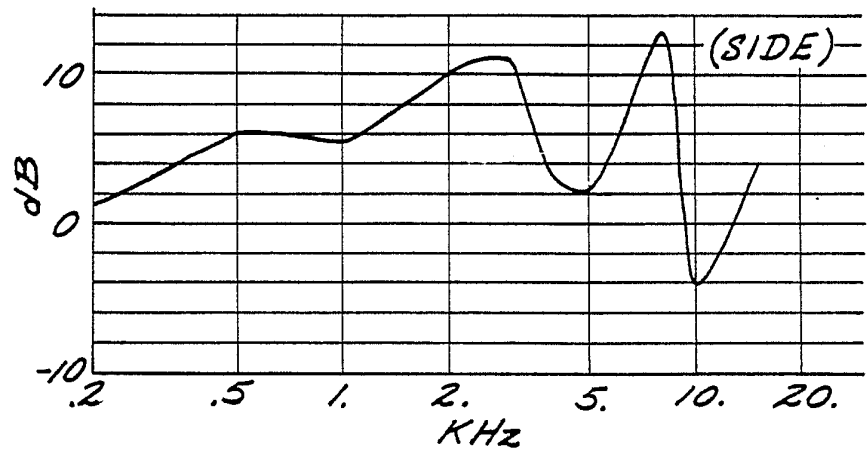

FIG. 7C

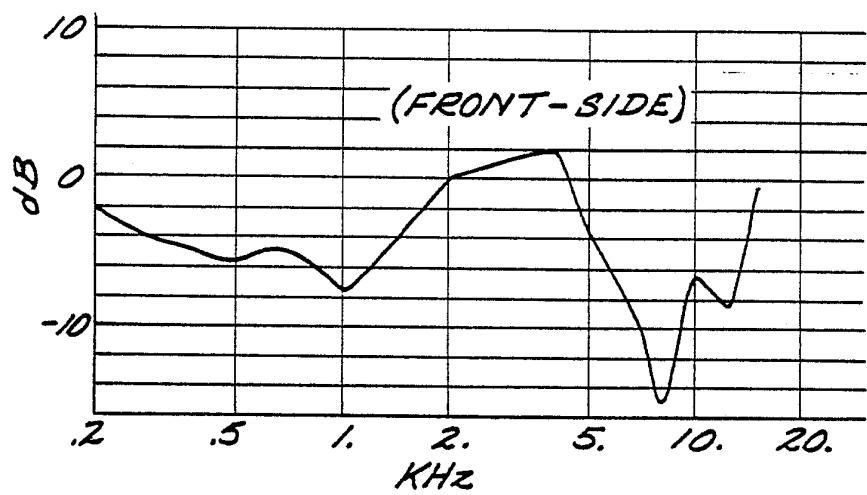
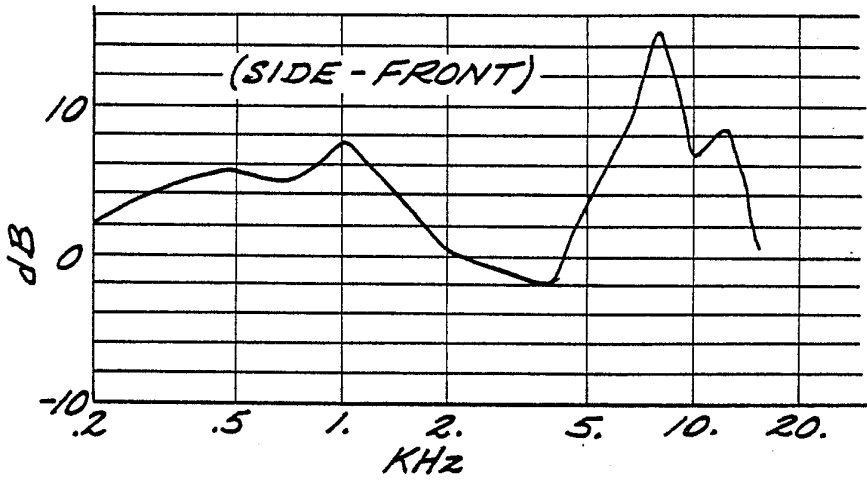

FIG. 7D



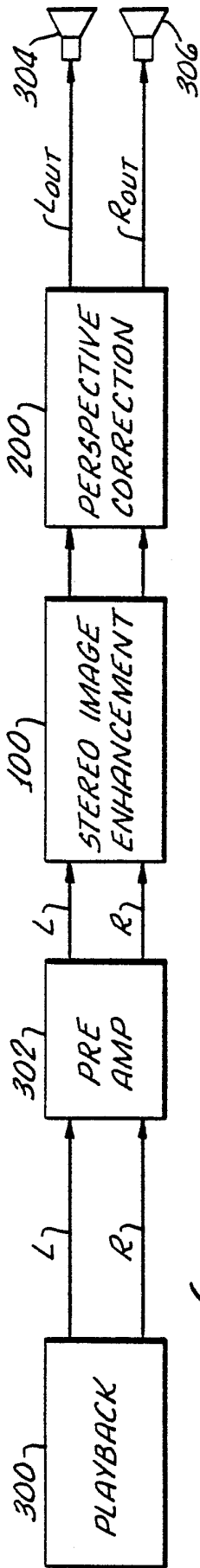

FIG. 8.

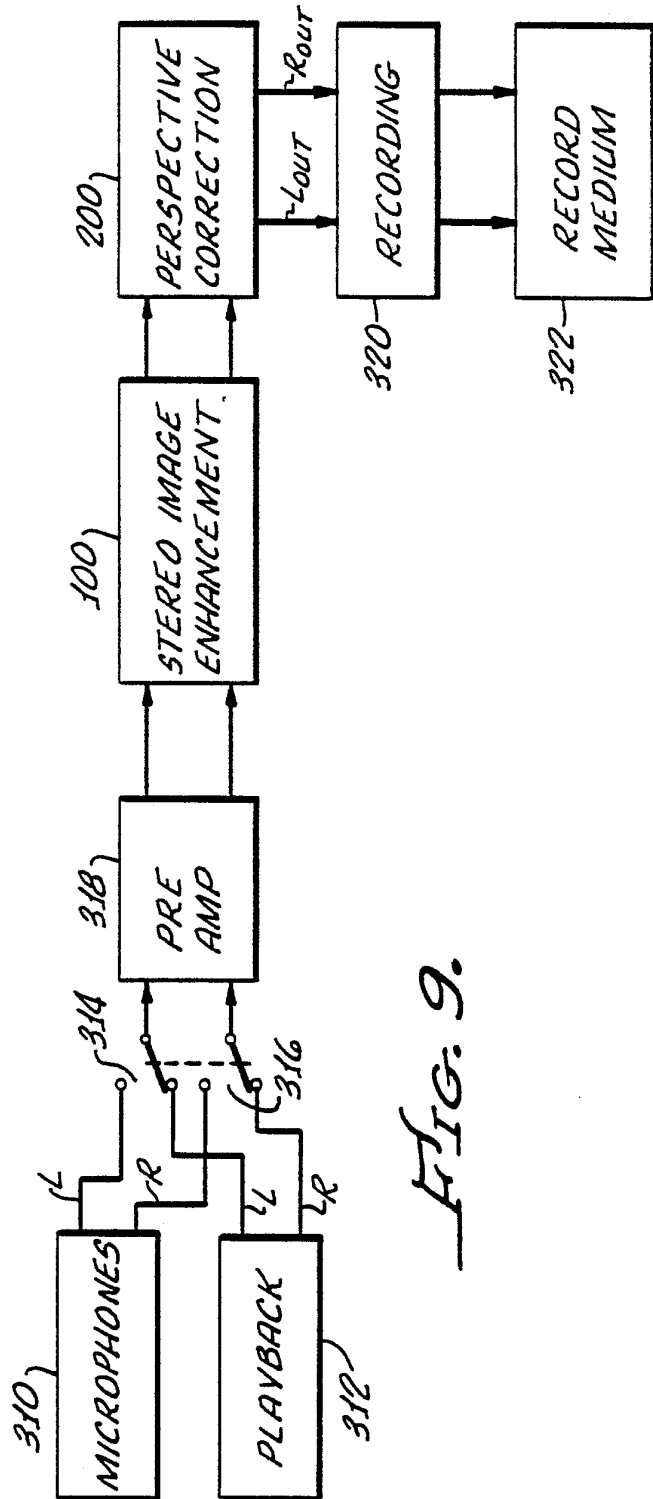

FIG. 9.

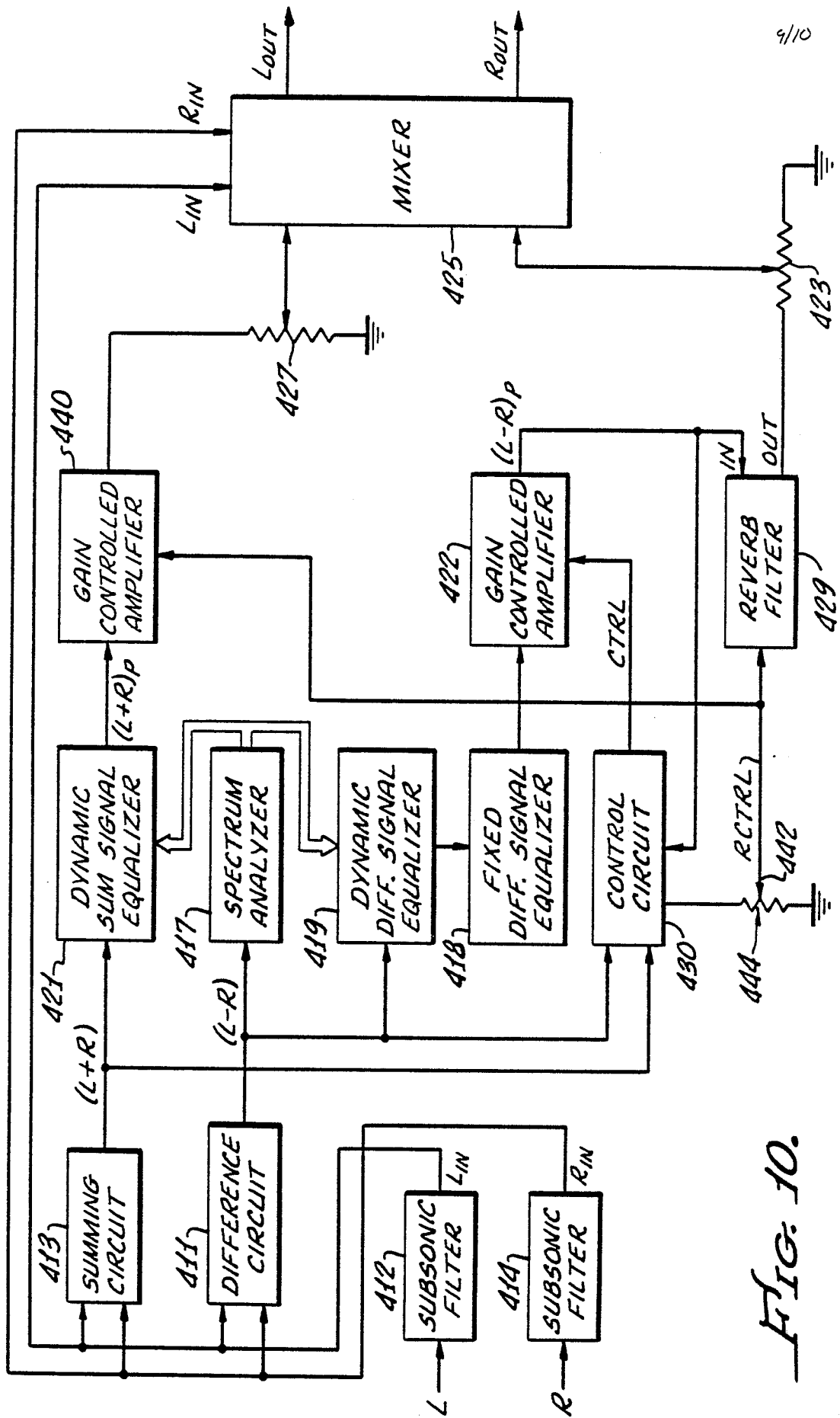

FIG. 10.

10/10

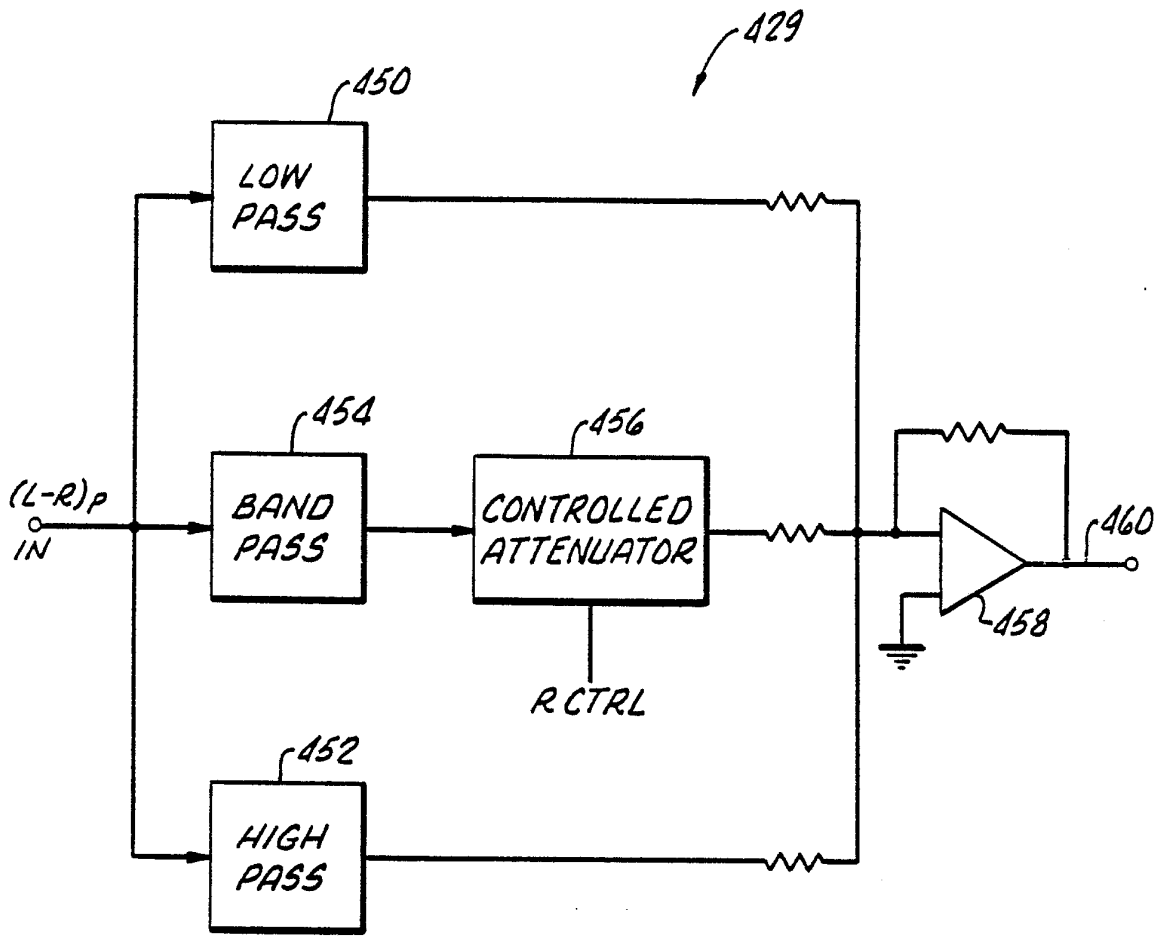
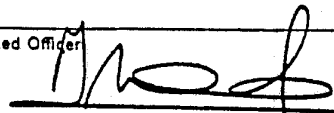

FIG. 11.

INTERNATIONAL SEARCH REPORT

International Application No PCT/US 87/00099

I. CLASSIFICATION OF SUBJECT MATTER (if several classification symbols apply, indicate all) *		
According to International Patent Classification (IPC) or to both National Classification and IPC		
IPC ⁴ : H 04 S 1/00; H 03 G 5/02		
II. FIELDS SEARCHED		
Minimum Documentation Searched ⁷		
Classification System	Classification Symbols	
IPC ⁴	H 04 S; H 03 G	
Documentation Searched other than Minimum Documentation to the Extent that such Documents are Included in the Fields Searched ⁸		
III. DOCUMENTS CONSIDERED TO BE RELEVANT ⁹		
Category ⁹	Citation of Document, ¹¹ with indication, where appropriate, of the relevant passages ¹²	Relevant to Claim No. ¹³
A	US, A, 4356349 (R. ROBINSON) 26 October 1982, see the whole document	1, 16, 33, 52, 61, 70, 80, 97, 109, 125
X	--	17, 42, 77, 87, 93
X	US, A, 4349698 (MAKOTO IWAHARA) 14 September 1982, see the whole document	28, 45, 50, 51, 78, 79, 90, 91
A	--	
A	US, A, 3772479 (F. HILBERT) 13 November 1973, see the whole document	1, 16, 17, 33, 42, 52, 61, 70, 77, 80, 87, 93, 97, 109, 125
A	--	
A	US, A, 4394536 (KENJI SHIMA) 19 July 1983, see the whole document	1, 8, 16, 17, 23, 33, 37, 42, 70, 80, 84, 86, 93, 95, 97, 101, 112, 117-122, 125 ./. .
<p>* Special categories of cited documents: ¹⁰</p> <p>"A" document defining the general state of the art which is not considered to be of particular relevance</p> <p>"E" earlier document but published on or after the international filing date</p> <p>"L" document which may throw doubts on priority claim(s) or which is cited to establish the publication date of another citation or other special reason (as specified)</p> <p>"O" document referring to an oral disclosure, use, exhibition or other means</p> <p>"P" document published prior to the international filing date but later than the priority date claimed</p> <p>"T" later document published after the international filing date or priority date and not in conflict with the application but cited to understand the principle or theory underlying the invention</p> <p>"X" document of particular relevance; the claimed invention cannot be considered novel or cannot be considered to involve an inventive step</p> <p>"Y" document of particular relevance; the claimed invention cannot be considered to involve an inventive step when the document is combined with one or more other such documents, such combination being obvious to a person skilled in the art.</p> <p>"&" document member of the same patent family</p>		
IV. CERTIFICATION		
Date of the Actual Completion of the International Search	Date of Mailing of this International Search Report	
12th June 1987	22 JUL 1987	
International Searching Authority	Signature of Authorized Officer	
EUROPEAN PATENT OFFICE	M. VAN MOL 	

III. DOCUMENTS CONSIDERED TO BE RELEVANT (CONTINUED FROM THE SECOND SHEET)		
Category *	Citation of Document, with indication, where appropriate, of the relevant passages	Relevant to Claim No
A	US, A, 3943293 (A. BAILEY) 9 March 1976, see the whole document	1, 5, 17, 18, 20, 33, 35, 39, 42, 43, 52, 61, 70, 76, 77, 80, 82, 86, 87, 93, 97, 109, 125
	--	
A	US, A, 4393270 (J. VANDEBERG) 12 July 1983, see the whole document	28-32, 45, 50, 51, 78, 79, 90, 91
	--	
A	US, A, 3989897 (R. CARVER) 2 November 1976, see claims; figures	1, 17, 33, 42, 52, 61, 70, 77, 80, 87, 93, 97, 109
	--	
A	EP, A, 0097982 (R. CARVER) 11 January 1984, see claims; figure 2 -----	1, 16, 17

ANNEX TO THE INTERNATIONAL SEARCH REPORT ON

INTERNATIONAL APPLICATION NO. PCT/US 87/00099 (SA 16016)

This Annex lists the patent family members relating to the patent documents cited in the above-mentioned international search report. The members are as contained in the European Patent Office EDP file on 03/07/87

The European Patent Office is in no way liable for these particulars which are merely given for the purpose of information.

Patent document cited in search report	Publication date	Patent family member(s)	Publication date
US-A- 4356349	26/10/82	CA-A- 1175362	02/10/84
US-A- 4349698	14/09/82	JP-A- 56001698	09/01/81
US-A- 3772479	13/11/73	None	
US-A- 4394536	19/07/83	JP-A- 57005499	12/01/82
US-A- 3943293	09/03/76	FR-A- 2205789	31/05/74
		DE-A- 2355881	06/06/74
		AU-A- 6227873	08/05/75
		GB-A- 1450533	22/09/76
		JP-A- 49102301	27/09/74
US-A- 4393270	12/07/83	NL-A- 7713076	30/05/79
US-A- 3989897	02/11/76	None	
EP-A- 0097982	11/01/84	JP-A- 59062236	09/04/84
		US-A- 4457012	26/06/84
		CA-A- 1188624	11/06/85

For more details about this annex :
see Official Journal of the European Patent Office, No. 12/82